

# **PHILMORE PORTABLE TRANSISTOR RADIO KIT**

The portable transistor radio kit is one of the most recent and startling innovations in the field of electronics. Taking advantage of the small size, long life, and low current consumption of the new transistors, this portable radio has been carefully designed, tested, improved - and is now an outstanding electronic success! It is compact, powerful, sensitive, and can operate for amazingly long periods of time on extremely small battery drain.

PHILMORE MANUFACTURING CO., INC., pioneering in electronics since the early days of the crystal radio, has led the field with a large number of items ranging from the tiny galena crystal to the fine quality Hi-Fi Amplifier Kit. And now, anticipating the future, PHILMORE takes the lead again, in craftsmanship and quality, with its new Transistor Kit.

When you have completed the actual construction of this set, following carefully our step-by-step instructions, your knowledge of present-day electronics will be substantially increased. You will have built a receiver that should be up-to-date for years to come - and your pride in your ability will add much to your enjoyment of the finished product!

## **HOW THE CIRCUIT WORKS**

(This is an engineering explanation, for technically inclined persons desiring to understand the circuit functioning of this receiver. However, this information is not at all necessary for the successful construction or operation of the set. So, if you'd rather not get involved in the "theoretical details" just skip this chapter and go on to the next.)

The Radio Frequency Signal is picked up by the Litz wirewound, high gain antenna loop coil. The signal is then fed to the base element of the RF amplifier transistor (similar to the grid of a vacuum tube) through the low impedance secondary winding (stepped down in impedance in order to more accurately match the low input impedance of the transistor).

The amplified radio frequency signal voltage is taken off the collector element (similar to the plate of a vacuum tube) of the R.F. Transistor and is fed thru C5 the R.F. coupling condenser to the germanium diode detector where the R.F. signal is rectified or detected (the process whereby the audio modulation is separated from the R.F. carrier).

The output of the germanium diode detector (audio signal voltage) is now put across the volume control, the center arm of which passes signal voltage thru audio coupling condenser C10 and the secondary winding L2 to the base element of the same input transistor. However, this time it is audio and not R.F. voltage and is further amplified (this type of circuit is commonly known as a reflex circuit, where one transistor or tube performs the amplifying function as both a radio frequency amplifier and an audio frequency amplifier at the same time).

Condenser C3 and C4 by-pass any radio frequency voltage present to ground in order to prevent such voltage from reaching the input circuit of the transistor.

The amplified audio voltage is then fed from the collector element of the input transistor thru L3 (which offers a low impedance path for audio voltage but a very high impedance path for R. F. voltage) thru audio coupling condenser C9 to the base element of the power output transistor in a conventional circuit hook up. The audio output transistor stage further amplifies the audio signal and builds it up to the amount of power necessary to operate the loudspeaker.



## LIST OF PARTS

For Portable Transistor Radio Kit

**NOTE:**-See Pictorial and Schematic diagrams for location of corresponding letters and numbers in parenthesis listed after part numbers.

PART NO.	QUANTITY	DESCRIPTION	PART NO.	QUANTITY	DESCRIPTION
TR235R(A)	1	Fibre Base Panel sub-assembly (with red dot)	TR222(R2)	1	2200 ohm Resistor
TR235G(B)	1	Fibre base Panel sub-assembly (with green dot)	TR223(R5)	1	5600 ohm Resistor
TR207(C)	1	Variable Tuning Condenser	TR224(R1, 4)	2	47000 ohm Resistors
TR232(D)	1	Positive Battery Mounting Bracket Assembly	TR225(R3)	1	56000 ohm Resistor
TR201(E)	1	Loudspeaker	TR226(R7)	1	1000 ohm Resistor
TR202(F)	1	Output Transformer	TR227(R8)	1	10000 ohm Resistor
TR206(G)	1	Volume Control with Switch	TR236	2	N.P. Flat Washers 3/8" hole (for Variable Condenser and Volume Control)
TR229(H)	1	1 Lug Terminal Strip	TR236A	2	3/8" Lockwashers (For Variable Condenser and Volume Control)
TR228(I)	1	7 Lug Terminal Strip	TR236B	1	Mounting Nut for Variable Condenser
TR209(J)	1	Antenna Loop Coil	TR236C	1	Mounting Nut for Volume Control
TR233(M)	1	Male Battery Snap Fastener Connector	* TR237	4	Rosette Screws 6/32 x 1/2" for mounting speaker
TR200	1	Portable Cabinet	TR239	6	6/32 x 1/2" Steel N.P. Hex Nuts - 4 to be used for mounting Speaker, and 2 to be used for mounting output Transformer
TR203(PH3)	1	Transistor (R.F.)	TR239A	6	#6 Lockwashers - to be used in same positions as TR239
TR204(PH2)	1	Transistor (Audio)	TR242	1	Set of Wiring Instructions and Diagrams
TR205(D1)	1	Germanium Diode	TR247	1	Piece Rosin Core Solder
TR208	2	Knobs	TR248	1	Piece Plastic Hook up Wire
TR213 (C9,10)	2	5 mfd. Electrolytic Condensers	TR250	1	Piece Spaghetti Tubing
TR214 (C7,8)	2	100 mfd. Electrolytic Condensers	TR251	1	Piece Bare Tinned Wire
TR215 (C2)	1	47 mmfd. Disc Condenser			
TR216 (C5)	1	100 mmfd. Disc Condenser			
TR217 (C3,4)	2	.005 mfd. Disc Condensers			
TR218 (C6)	1	.01 mfd. Disc Condenser			
TR219 (L3)	1	R. F. Coil (red)			
TR219A(L5)	1	R.F. Coil (red with green dot)			
TR220(L4)	1	R. F. Coil (Brown)			
TR221(R6)	1	150 ohm Resistor			

\* Two of the screws are used to hold down the antenna loop coil on the display platform.

## STEP-BY-STEP ASSEMBLY INSTRUCTIONS

1. Holding the opened cabinet as shown in the assembly drawing instruction sheet, mount the loudspeaker "E" on the inside of the cabinet (with the two lug terminal strip facing to the right as shown on the drawing) with the four 6/32 rosette head screws #26, #27, #29, and #31.

PLEASE REFER TO NOTE NO.6 ON PAGE 5

2. Before applying the 6/32 nuts to the screws, other parts must be put on these screws as follows:
3. Lay the fibre base panel "A" (identified with a red dot painted on its upper Left hand corner) thru the two holes provided in it over the two speaker mounting screws #26 and #31.
4. Now lay the fibre base panel "B" (identified with a green dot painted on its upper right hand corner) thru the two holes provided for same over the two speaker mounting screws shown as #27 and #29 on the assembly drawing, and apply a 6/32 nut and tighten to the #29 screw only.
5. Take the antenna loop coil ("J" on drawing) and hold it so that the three wires emerging from same are on the right hand side and the single wire is on the left hand side, place the mounting hole of the loop coil mounting strap ("K" on the drawing) over the speaker mounting screw #26 and duplicate the same procedure with the other loop coil mounting strap "L" and place its strap hole over speaker mounting screw #27.
6. Now take the #7 lug terminal strip (part "I" on drawing) and place as shown with its mounting hole of lug #5 placed over speaker mounting screw #26 and secure down with a 6/32 nut and #6 lockwasher.

7. Place the one lug terminal strip (Part H) over the speaker mounting screw #27 as shown.
8. The mounting hole on the bracket of the PH2 power transistor is now placed over the #27 speaker mounting screw and tightened down with a 6/32 nut and lockwasher and positioned as shown on drawing.
9. Now mount the positive battery mounting bracket assembly "D" (with Fahnestock Clip, Female Snap Fastener and solder lug attached) onto the speaker mounting screw #31 as shown, and secure with #6/32 nut and lockwasher.
10. The output transformer is mounted by facing the side from which the red and blue wires emerge toward the loudspeaker, and placing the output transformer mounting holes over the two mounting screws #29 and #30, and securing each down with a 6/32 nut and lockwasher.
11. Mount the volume control and switch "G" by placing a 3/8" ID lockwasher over the shaft bushing and insert thru the holes in the "B" base panel and the cabinet, and fasten by applying a 3/8" ID Flatwasher and volume control nut from the front of the cabinet. Position the control as shown on the drawing.
12. Mount the variable tuning condenser "C" (by the same method as the volume control in step # 11 above) using the nut, lockwasher and flatwasher supplied on the condenser. Position this part as shown on the drawing.
13. Using a small screwdriver, fasten the two knobs supplied (one on the tuning condenser shaft and the other on the volume control shaft) by tightening the set screws on each knob.



If you have carefully followed the steps up to this point, and double checked, you are now ready to proceed with your wiring connections. With the aid of the drawings provided, it should not take long.

PLEASE REFER TO NOTE #1 ON PAGE 5

<u>STEP #</u>	<u>CONNECT (Component)</u>	<u>FROM</u>	<u>TO</u>
14.	5" length of Wire	#1 Lug of "I"	#17 Lug of "C"
15.	4½" " " "	#25 Lug of "G"	Male Battery Snap Fastener Connector "M"
16.	6" " " "	#6 Lug of "I"	#9 Lug
17.	10" " " "	#7 Lug of "I"	#23 Lug of "G"
18.	9" " " "	#3 Lug of "I"	#24 Lug of "G"
PLEASE REFER TO NOTE #2 ON PAGE 5			
19.	Antenna Loop Coil ("J")	#1 Wire	#16 Lug "C"
20.	" " " ("J")	#2 Wire	#12 Lug
21.	" " " ("J")	#3 Wire	#33 Lug
22.	" " " ("J")	#4 Wire	#19 Lug of "E"
23.	5½" length of Wire (Bare)	#19 Lug of "E"	#35 of "E" then to
24.	Above wire makes 4 connections	#32 Lug of "D"	#17 Lug of "C"
25.	4" length of Wire	#19 Lug of "E"	#21 Lug of "G"
26.	Red Wire	Output Trans. "F"	#10 Lug
27.	Blue Wire	" " " "F"	#24 Lug of "G"
28.	Enameled Wire (either one)	" " " "F"	#19 Lug of "E"
29.	Other Enameled Wire	" " " "F"	#20 Lug of "E"
PLEASE REFER TO NOTE #3 ON PAGE 5			
30.	5 mfd. Condenser C9	(Negative End of C9)	#2 Lug of "I"
31.	5 mfd. Condenser C9	(Positive End of C9)	#6 Lug of "I"
32.	5 mfd. Condenser C10 (Place BELOW Red Wire)	(Positive End of C10)	#22 Lug of "G"
33.	5 mfd. Condenser C10	Use 1" Spaghetti Tubing on this Wire (Negative End of C10)	#33 Lug
34.	2200 ohm resistor R2	#2 Lug of "I"	#3 Lug of "I"
35.	47000 " " R4	#3 Lug of "I"	#6 Lug of "I"
36.	1000 " " R7	#11 Lug	#1 Lug of "I"
37.	5600 " " R5	#1 Lug of "I"	#6 Lug of "I"
PLEASE REFER TO NOTE #4 ON PAGE 5			
38.	Germanium Diode "D1"	#4 Lug of "I"	#7 Lug of "I"
39.	R. F. Coil L3 (Red)	#2 Lug of "I"	#13 Lug
40.	R. F. Coil L4 (Brown)	#4 Lug of "I"	#15 Lug
41.	R. F. Coil L5 (Red & Green)	#17 Lug of "C"	#15 Lug
PLEASE REFER TO NOTE #7 ON PAGE 5			
42.	56000 ohm Resistor R3	#12 Lug	#13 Lug
PLEASE REFER TO NOTE #5 ON PAGE 5			
43.	100 mmfd. discap Condenser C5	#13 Lug	#4 Lug of "I"
44.	47 mmfd. discap Condenser C2	#14 Lug of "C"	#16 Lug of "C"



<u>STEP #</u>	<u>CONNECT (Component)</u>	<u>FROM</u>	<u>TO</u>
45.	100 mfd. Condenser C7	Negative End of C7	#11 Lug
46.	" " " C7	Positive End of C7	#32 Lug
47.	" " " C8	Negative End of C8	#8 Lug
48.	" " " C8	Positive End of C8	#21 Lug of "G"
49.	150 ohm Resistor R6	#8 Lug	#21 Lug of "G"
50.	.005 discap Condenser C4	#21 Lug of "G"	#23 Lug of "G"
51.	" " " C3	#33 Lug	#19 Lug of "E"
52.	10,000 ohm Resistor R8	#33 Lug	#19 Lug of "E"
53.	47,000 ohm Resistor R1	#33 Lug	#24 Lug of "G"
54.	.01 mfd. discap Condenser C6	#10 Lug	#24 Lug of "G"
55.	Now, re-check each connection, one at a time, and then solder.		
56.	Insert the PH2 audio power transistor leads into the Fahnestock Clips as follows: (Refer to assembly drawing which identifies the transistor connections) The emitter wire of PH2 is inserted into Fahnestock Clip #8, the base wire into Clip #9, and the collector wire into Clip #10.		
	NOTE: The center transistor wire lead (base) is spaced closer to the emitter wire lead, and there is a wider space between the center wire lead and the collector wire lead.		
57.	Insert the PH3 transistor into the Fahnestock Clips as follows: The emitter wire into Clip #11, the base wire into Clip #12, and the collector wire into Clip #13. Refer to assembly drawing which identifies the transistor connections.		
58.	Now insert the positive end of the battery (not supplied) into the positive snap clip on the positive battery support bracket (D) and then fasten the negative male snap fastener clip (on end of wire that goes to lug #25) to the battery by applying pressure until it snaps into place.		
	You may now pat yourself on the back for a job well done. We hope you found it both interesting and challenging.		
	NOTE: The plastic cabinet can easily be cleaned by the application of a damp cloth moistened with ordinary soap and water.		

## OPERATING INSTRUCTIONS

The set is now ready to operate. Turn the volume control knob clock-wise until a click is heard. This connects the battery to the set. Rotate the knob in a clock-wise direction to increase the volume and in a counter-clock-wise direction to decrease the volume.

Now rotate the tuning control knob to the desired station and adjust the volume control for best reception.

Since the high gain antenna loop coil is highly directional in performance, (a condition which exists in all radios utilizing such a built-in antenna) it may be necessary to rotate the set slightly in order to obtain best reception for very weak or distant stations.

To turn the set off, rotate the volume control counter-clock-wise until a distinct clicking sound is heard.

For average receiving conditions and locations (even in large city suburbs) no outside antenna or ground is necessary. However, in locations distant from a radio station it may be desirable to add a short length of wire (from 2 to 10 feet long) to the antenna Fahnestock Clip connector mounted on Variable Condenser "C" (#14 on drawing). In some instances a ground wire might also be beneficial to distant reception. This wire is connected from any cold water pipe or radiator pipe to the ground Fahnestock (#34 on assembly drawing) located on the positive battery support bracket assembly ("D").



**NOTE NO. 1** - Refer to assembly drawing color code chart to identify value of Resistors. Use insulated solid tinned copper wire size #20 or #22. Use Rosin Cored Solder only. (50-50 or 60-40 being acceptable.)

**CAUTION!**

Do not use acid core solder, acid paste or liquid solder, as these will corrode the connections, and void the parts guarantee.

**NOTE NO. 2** - Refer to drawing of Antenna Loop Coil on assembly drawing.

**NOTE NO. 3** - In some kits, one of the two 5 mfd. Condensers furnished is smaller in physical size than the other. The smaller one is to be used as C-9 and placed in between the "K" strap of the antenna loop coil and the plastic cabinet with the positive terminal on the right and the negative terminal on the left. The larger 5 mfd. condenser is C10, and is used elsewhere in the kit, as per step #32.

**NOTE NO. 4** - The germanium diode is polarized. One end has a printed line going about half way around. This end is the cathode and should be connected to #7 Lug of the 7 Lug terminal strip. The other end, of course, is connected to #4 Lug on the same terminal strip (as per wiring step #38).

**NOTE NO. 5** - The 100 mmfd. discap condenser referred to in step #43 is flat and circular in shape and approximately one-quarter of an inch in diameter, and should not be confused with the 100 mfd. tubular electrolytic condensers used elsewhere in this kit.

**NOTE NO. 6** - In order to facilitate ease of assembly, it is suggested that a small piece (1") of scotch tape be applied to the heads of each of the four rosette Speaker mounting screws, and the front of the cabinet. This is to be done temporarily in order to hold the screws in place, and prevent them from falling out during the assembly operation. After the assembly is completed the tape is to be removed.

**NOTE NO. 7** - R-3 56,000 ohm resistor functions to stabilize the circuit. This is made necessary due to the slight variation in characteristics of transistors of different manufacture. In many cases, however, it will be found that ELIMINATING R-3 resistor does not affect the stability of the circuit, but does increase the overall gain.







# PHILMORE PORTABLE TRANSISTOR RADIO KIT ASSEMBLY DRAWING

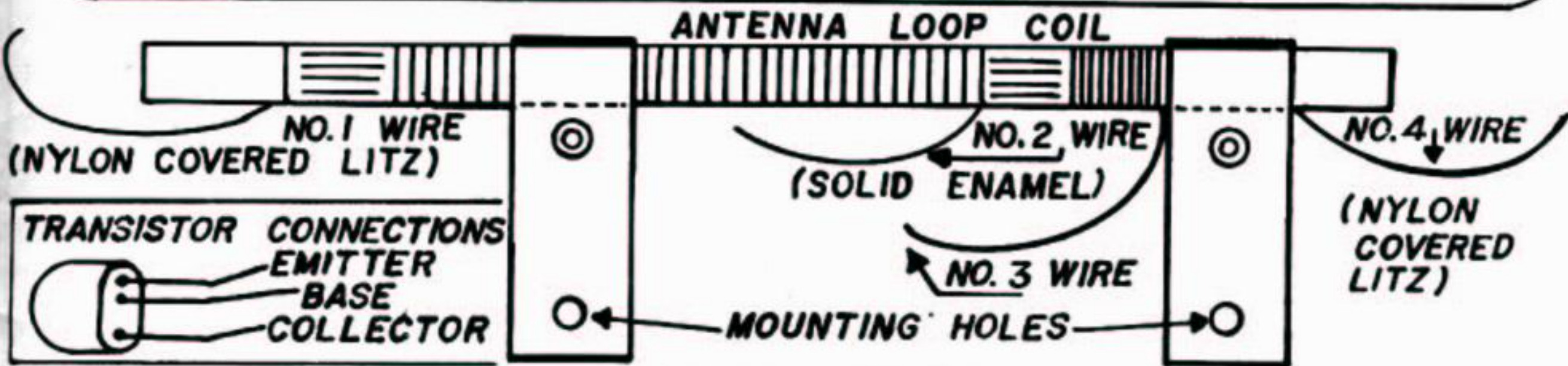
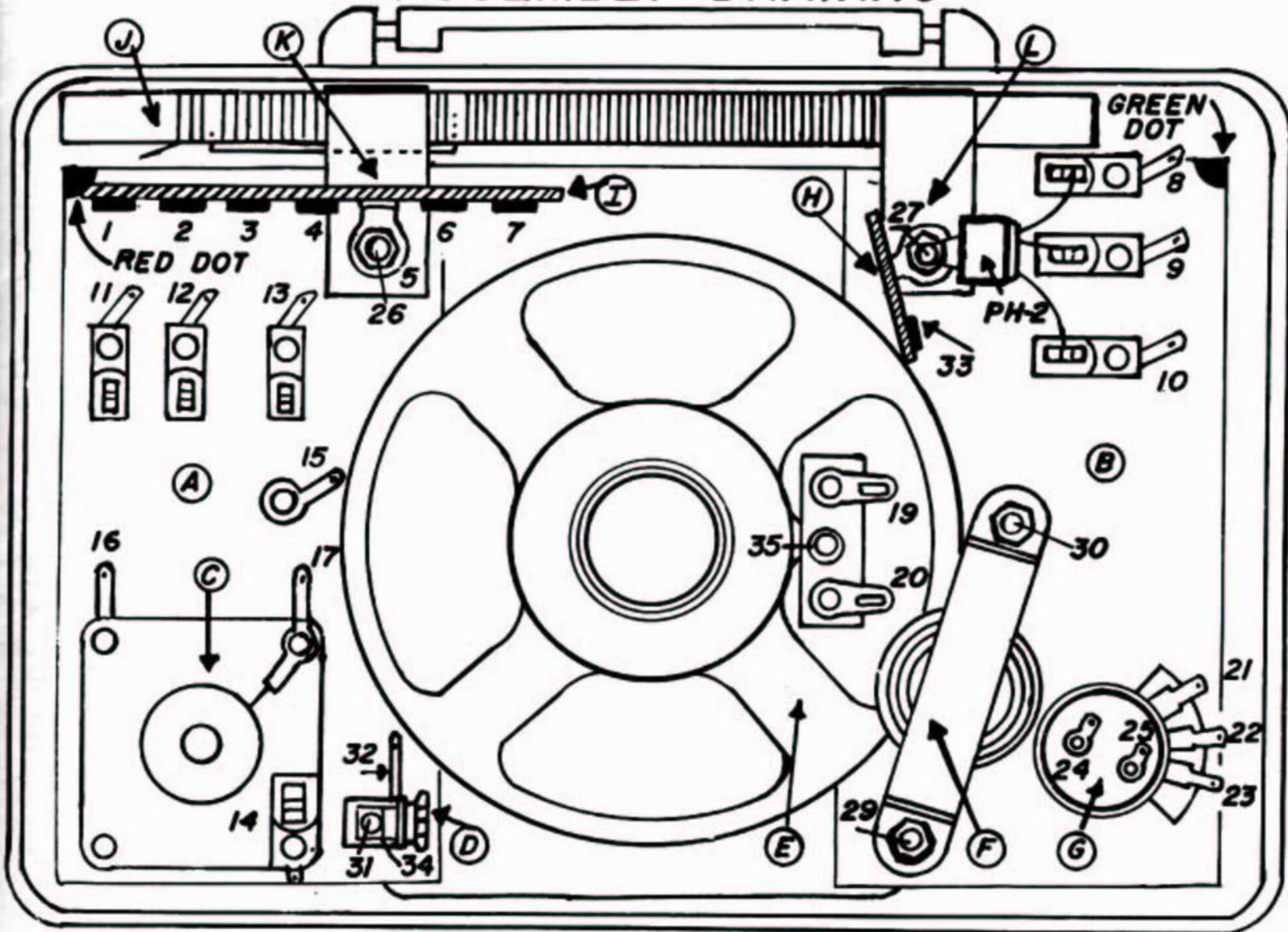

## RESISTOR COLOR CODE CHART

RESISTOR	FIRST BAND	SECOND BAND	THIRD BAND	RESISTOR	FIRST BAND	SECOND BAND	THIRD BAND
150 OHMS	BROWN	GREEN	BROWN	10,000 OHM	BROWN	BLACK	ORANGE
1000 "	BROWN	BLACK	RED	47,000 "	YELLOW	PURPLE	ORANGE
2200 "	RED	RED	RED	56,000 "	GREEN	BLUE	ORANGE
5600 "	GREEN	BLUE	RED	SILVER BAND MEANS 10% TOLERANCE			



SCHEMATIC DIAGRAM

# PORTABLE TRANSISTOR RADIO KIT

PHILMORE MFG. CO. INC.  
N.Y. 3, N.Y.

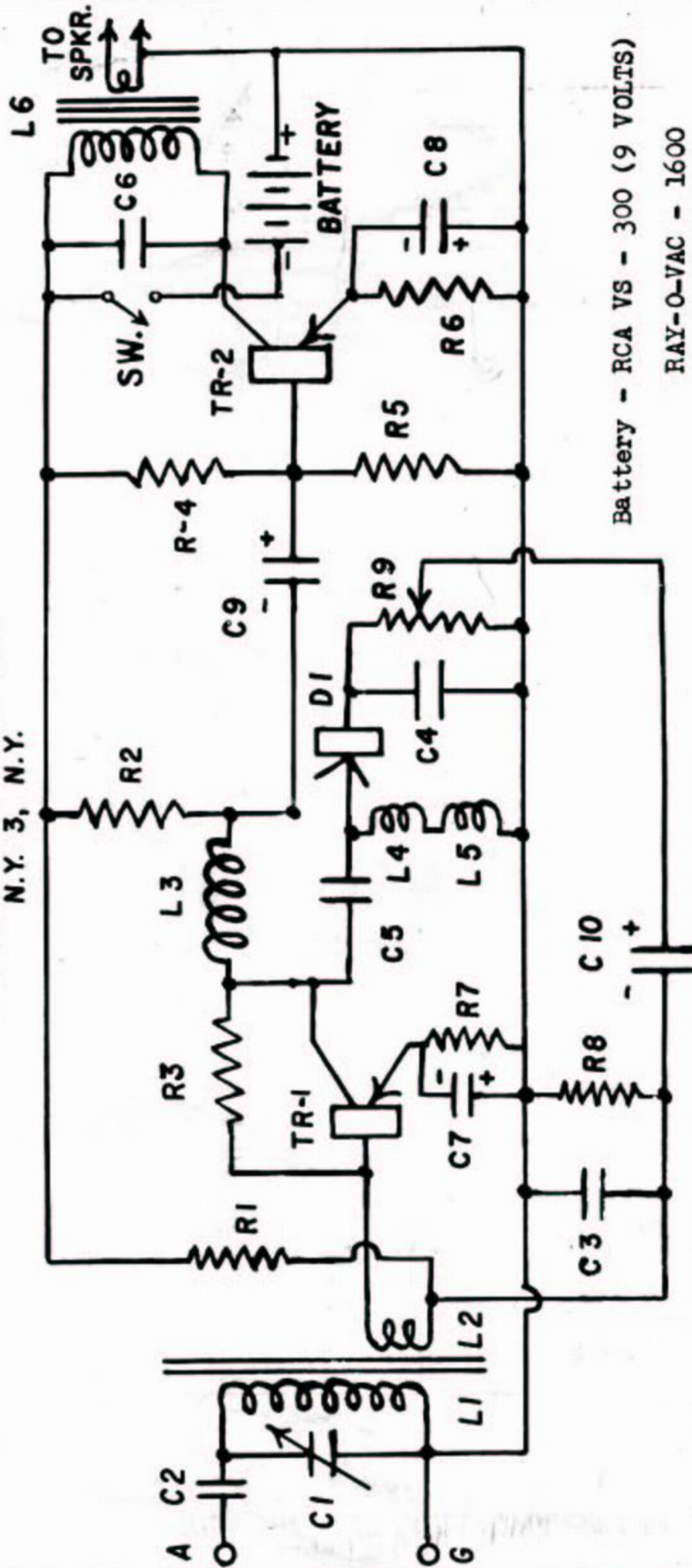

Battery - RCA VS - 300 (9 VOLTS)

RAY-O-VAC - 1600

- C1 - 400 MMFD.
- C2 - Var. Cond.
- C3, C4 - .005 MFD.
- C5 - 100 MMFD.
- C6 - .01 MFD.
- C7, C8 - 100 MFD.
- C9, C10 - 5 MFD.

- R1, R4 - 47,000 OHMS
- R2 - 2,200 OHMS
- R3 - 56,000 OHMS
- R5 - 5,600 OHMS
- R6 - 150 OHMS
- R7 - 1,000 OHMS
- R8 - 10,000 OHMS
- R9 - 10,000 OHMS

Volume Control & Switch  
(R1 TO R3 1/2W. 10%)

- L1) PRI. ANT. LOOPSTICK
- L2( SEC. "
- L3) -R.F. COIL (RED)
- L4 - DET. COIL (BROWN)
- L5 - DET. COIL (RED & GREEN)
- L6 - OUTPUT TRANSFORMER

- TR1 - PHILMORE TRANSISTOR PH3
- TR2 - " PH2
- DI - GERMANIUM DIODE IN34

NOTE - PHILMORE TRANSISTOR PH3  
CAN BE REPLACED BY 2N136,  
2N112, CK760, GT761

PHILMORE TRANSISTOR PH2  
CAN BE REPLACED BY GT81  
2N138, 2N109, 2N44