

TW-PRC1077-MS1

TRANS WORLD COMMUNICATIONS TECHNICAL MANUAL

Service and Technical Manual

RADIO SET PRC1077



TRANS WORLD COMMUNICATIONS, INC.

A COATRON COMPANY

304 Enterprise Street, Escondido, California, 92029 U.S.A.

TELEX 695-433 PHONE (619) 747-1079 FAX (619) 741-1658

AL MANUAL
SET PROTON

MANUAL
PROTON

1988
1989
1990

**TECHNICAL MANUAL MSI
RADIO SET PRC1077**



1917

1918

1919

1920

1921

1922

1923

1924

1925

1926

1927

1928

1929

1930

1931

1932

1933

1934

1935

1936

1937

1938

1939

1940

1941

1942

1943

1944

1945

1946

One Year Limited Warranty and Remedies

Datron World Communications Inc. (DWC) warrants that its equipment is free from defects in design, materials and workmanship for a period of 12 months from the date of installation of the equipment, but in no event later than 15 months from the date of shipment. If the equipment does not provide satisfactory service due to defects covered by this warranty, DWC will, at its option, replace or repair the equipment free of charge.

Should it be impractical to return the equipment for repair, DWC will provide replacements for defective parts contained in the equipment for a period of 12 months from the date of installation of the equipment, but in no event later than 15 months from the date of shipment.

This warranty is limited to the original purchaser and is not transferable. Repair service performed by DWC is warranted for the balance of the original warranty or 90 days, whichever is longer.

Exclusive Warranty: There are no other warranties beyond the warranty as contained herein. No agent, employee, or representative of DWC has any authority to bind DWC to any affirmation, representation, or warranty concerning the equipment or its parts that is not in conformity with the warranties contained herein. EXCEPT AS EXPRESSLY SET FORTH ABOVE, NO OTHER WARRANTIES, EITHER EXPRESS OR IMPLIED, ARE MADE WITH RESPECT TO THE EQUIPMENT OR THE PARTS CONTAINED THEREIN, INCLUDING BUT NOT LIMITED TO THE IMPLIED WARRANTIES OF MERCHANTABILITY AND FITNESS FOR A PARTICULAR PURPOSE, AND DWC EXPRESSLY DISCLAIMS ALL WARRANTIES NOT STATED HEREIN.

Limitations of Warranty: This warranty does not cover:

- Physical damage to the equipment or its parts that does not involve defects in design, material or workmanship, including damage by impact, liquids, temperature, or gases;
- Damage to the equipment or its parts caused by lightning, static discharge, voltage transients, or application of incorrect supply voltages.
- Defects or failures caused by unauthorized attempts to repair or modify the equipment.
- Defects or failures caused by Buyer abuse or misuse.

Return of Equipment - Domestic: To obtain performance of any obligation under this warranty, the equipment must be returned freight prepaid to the Customer Service Department, Datron World Communications Inc., 304 Enterprise Street, Escondido, California 92029. The equipment must be packed securely. DWC shall not be responsible for any damage incurred in transit. A letter containing the following information must be included with the equipment.

- a. Model, serial number and date of installation;
- b. Name of dealer or supplier of the equipment;
- c. Detailed explanation of problem;
- d. Return shipping instructions; and
- e. Telephone or fax number where buyer may be contacted.

DWC will return the equipment prepaid by United Parcel Service, Parcel Post, or truck. If alternate shipping is specified by Buyer, freight charges will be made collect.

Return of Equipment - International: Contact DWC or your local Representative for specific instructions. Do not return equipment without authorization. It is usually not possible to clear equipment through U.S. Customs without the correct documentation. If equipment is returned without authorization, Buyer is responsible for all taxes, customs duties, clearance charges, and other associated costs.

Parts Replacement: The following instructions for the supply of replacement parts must be followed:

- a. Return the parts prepaid to "Parts Replacement" Datron World Communications Inc., 304 Enterprise Street, Escondido, California 92029; and
- b. Include a letter with the following information:
 1. part number;
 2. serial number and model of equipment; and
 3. date of installation.

Parts returned without this information will not be replaced. In the event of a dispute over the age of the replacement part, components date-coded over 24 months previously will be considered out of warranty.

Remedies: Buyer's sole remedies and the entire liability of DWC are set forth above. In no event will DWC be liable to buyer or any other person for any damages, including any incidental or consequential damages, expenses, lost profits, lost savings, or other damages arising out of use of or inability to use the equipment.

1/96

TABLE OF CONTENTS

CHAPTER 1 - INTRODUCTION & TECHNICAL SPECIFICATIONS

PARAGRAPH		PAGE
1-1	General	1-1
1-2	Operator's Manual	1-1
1-3	Technical Specifications	1-1

CHAPTER 2 - SERVICE & MAINTENANCE

2-1	Scope	2-1
2-2	General	2-1
2-3	Operator's (Preventive) Maintenance	2-1
2-3.1	Systematic Care	2-1
2-3.2	Completeness of Accessories	2-3
2-3.3	Cleaning	2-3
2-3.4	Malfunction - Visual Inspection	2-3
2-3.5	Operational Checklist	2-3
2-4	Field Maintenance	2-4
2-4.1	Tools and Accessories Required	2-4
2-4.2	Maintenance Intervals	2-4
2-4.3	Field Maintenance Checklist	2-4
2-4.4	Performance Checks	2-4
2-4.5	Internal Inspection	2-8
2-5	Field Service	2-9
2-5.1	Basic Module Fault Location	2-9
2-5.2	Access & Module Removal	2-9
2-6	Depot Service	2-9
2-6.1	Test Equipment	2-9
2-6.2	Power Measurement	2-9
2-6.3	Spectrum Analyzer	2-9
2-6.4	Signal Generator	2-9
2-6.5	Frequency Counter	2-9
2-6.6	Semiconductor Servicing	2-9
2-6.7	Component Replacement	2-12

CHAPTER 3 - GENERAL THEORY OF OPERATION

3-1	Introduction	3-1
3-2	Synthesizer	3-1
3-3	Microprocessor	3-1
3-4	Receiver	3-1
3-5	Transmitter	3-1
3-6	Antenna Tuner	3-2
3-7	Signal Flow Charts	3-2

CHAPTER 4 - AUDIO MODULE, M1 - THEORY OF OPERATION

4-0	Introduction	4-1
4-1	Module Interconnections	4-1
4-2	Circuit Description	4-1
4-2.1	Transmit Function	4-1
4-2.2	Receive Function	4-2
4-2.3	Control Circuitry	4-3
4-3	Voltage Charts	4-3
4-4	Alignment	4-3
4-4.1	Deviation Level	4-3

CHAPTER 5 - SYNTHESIZER MODULE, M2 - THEORY OF OPERATION

5-0	Introduction	5-1
5-1	Module Interconnections	5-1
5-2	Circuit Description	5-1
5-2.1	VCOs	5-1
5-2.2	Synthesizer	5-1
5-2.3	VCO Switches And Decoding	5-3
5-3	Detailed Theory Of Operation	5-3
5-4	Voltage Charts	5-4
5-5	Test and Alignment	5-4

CHAPTER 6 - PROCESSOR MODULE, M3 - THEORY OF OPERATION

6-0	Introduction	6-1
6-1	Module Interconnections	6-1
6-2	Circuit Description	6-2
6-3	Voltage Charts	6-3
6-4	Test and Alignment	6-3

CHAPTER 7 - TRANSMITTER MODULE, M4 - THEORY OF OPERATION

7-0	Introduction	7-1
7-1	Module Interconnections	7-1
7-2	Circuit Description	7-1
7-3	Voltage Charts	7-2
7-4	Test and Alignment	7-2

CHAPTER 8 - RECEIVER MODULE, M5 - THEORY OF OPERATION

8-0	Introduction	8-1
8-1	Module Interconnections	8-1
8-2	Circuit Description	8-1
8-3	Voltage Charts	8-2
8-4	Test and Alignment	8-2

CHAPTER 9 - DISPLAY BOARD MODULE, M6 - THEORY OF OPERATION

9-0	General	9-1
9-1	Module Interconnections	9-1
9-2	Circuit Description	9-1

CHAPTER 10 - ANTENNA TUNER MODULE, M7 - THEORY OF OPERATION

10-0	Introduction	10-1
10-1	Module Interconnections	10-1
10-2	Circuit Description	10-1
10-3	Voltage Charts	10-2
10-4	Test and Alignment	10-2

CHAPTER 11 - CHASSIS/MAINFRAME

11-1	General	11-1
------	---------------	------

CHAPTER 12 - TACSEC EMBEDDED TACTICAL SECURITY OPTION

12-1	Introduction	12-1
12-2	Technical Description	12-1
12-2.1	Programming Options	12-1
12-3	Options	12-1
12-3.1	Automatic Number Identification	12-1
12-3.2	"Stunning"	12-1
12-3.3	Key Change	12-1
12-4	Circuit Description	12-1
12-5	Radio Operating Instructions	12-1

APPENDIX A

A-1	General	A-1
A-2	Block Diagram Description	A-1
A-2.1	Programming Signals	A-1
A-2.2	VCO Band Selection	A-2
A-2.3	Phase Detector	A-2
A-3	Phase Locked Loops	A-2
A-4	Dual Modulus Prescaling	A-4
A-5	Frequency Programming	A-4
A-5.1	Frequency Programming Example	A-4
A-6	Frequency Conversion Scheme	A-5

APPENDIX B - OPTIONAL ACCESSORY EQUIPMENT

B-1	General	B-1
B-2	Explanation of Columns	B-1
B-3	Installation and Use of Optional Accessory Items	B-5
B-4	Battery Charging Using the PRC-PS Power Supply/Charger	B-5
B-5	Battery Charging Using the PRC-BC4	B-5
B-6	Battery Charging Using the PRC-HC-30 Hand-Crank Generator	B-5
B-7	Battery Charging Using the PRC-SPU-10 Solar Power Generator	B-5
B-8	Mobile 5-W System Operation	B-6
B-9	Mobile 50-W System Operation	B-6
B-10	Mobile 5-W System With U.S. Mil Mount	B-6
B-11	Mobile 50-W System with U.S. Mil Mount	B-6
B-12	Mobile/Portable 50-W System	B-6

FIGURES

1-1	30- to 88-MHz Packset Transceiver	viii
1-2	Block Diagram	1-8
1-3	Module Locations - Top	1-9
1-4	Module Locations - Bottom	1-10
2-1	Radio Set PRC1077, Components	2-2
2-2	Installation and Removal of Battery in Transceiver	2-6
2-3	Receiver/Trasnmitter, Radio Set PRC1077, Organizational Repair Parts	2-7
4-1	Component Locations, Audio Module, M1	4-6
4-2	Schematic Diagram, Audio Module, M1	4-7
5-1	Block Diagram	5-2
5-2	Component Location Diagram, Synthesizer Module, M2	5-10
5-3	Schematic Diagram, Synthesizer Module, M2	5-11
6-1	Component Location Diagram, Processor Module, M3A	6-10
6-2	Schematic Diagram, Processor Module, M3A	6-11
6-3	Component Location Diagram, Switch Module, M3B	6-14
6-4	Schematic Diagram, Switch Module, M3B	6-15
7-1	Component Location Diagram, Transmitter Module, M4	7-4
7-2	Schematic Diagram, Transmitter Module, M4	7-5
8-1	Component Location Diagram, Receiver Module, M5	8-4
8-2	Schematic Diagram, Receiver Module, M5	8-5
9-1	Component Location Diagram, Display Module, M6	9-4
9-3	Schematic Diagram, Display Board Module, M6	9-5

FIGURES (Continued)

10-1	Component Locations, Antenna-Tuner Module, M7	10-4
10-2	Schematic Diagram, Antenna-Tuner Module, M7	10-5
11-1	Module Locations, Top View	11-1
11-2	Module Locations, Bottom View	11-2
11-3	Schematic Diagram, Mainframe	11-3
A-1	Synthesizer Block	A-1
A-2	Phase Locked Loop	A-2
A-3	Dual Modulus Prescaler	A-3
A-4	Serial Data Format	A-5
B-1	Operation of PRC-PS into PRC1077.	B-7
B-2	Operation of PRC-PS into Separate Battery	B-7
B-3	Operation of PRC-BC4 with Batteries	B-8
B-4	Battery Charging Using the PRC-HC-30 and PRC1077	B-8
B-5	Battery Charging Using the PRC-HC-30 Directly	B-8
B-6	Battery Charging Using the PRC-SPU-10 and PRC1077	B-9
B-7	Battery Charging Using the PRC-SPU-10 Directly	B-9
B-8	PRC1077/VRC-64 Mobile 5-W System (24 Vdc)	B-9
B-9	PRC1077/VRC-46 Mobile 50-W System (24 Vdc)	B-10
B-10	PRC1077/OA3633/SYS Mobile 5-W System with U.S. Military Mount (24 Vdc)	B-10
B-11	PRC1077/AM-1077/OA3633/SYS Mobile System with U.S. Military Mount (24 Vdc)	B-11
B-12	Mobile/Portable 50-W System (24 Vdc)	B-11

TABLES

1-1	Technical Specifications	1-1
1-2	Semiconductors	1-4
2-1	Operator's Daily Preventive Maintenance Checks and Services Chart	2-1
2-2	Operator's Weekly Preventive Maintenance Checks and Services Chart	2-1
2-3	PRC1077 Operational Checklist	2-3
2-4	Field Maintenance Checklist	2-4
2-5	General Fault-Location Chart	2-8
2-6	Module Function Chart	2-10
2-7	Test Equipment	2-12
3-1	Receive Signal Flow	3-3
3-2	Transmit Signal Flow	3-4
4-1	M1 Dc Voltage Charts	4-4
4-2	Parts List, Audio Module, M1	4-9
5-1	M2 Module Dc Voltages	5-5
5-2	Software Configuration vs. Varactor Type	5-8
5-3	VCO/Filter Band Adjustments and Band Frequencies	5-9

TABLES (Continued)

5-4	Parts List, Synthesizer Module, M2	5-13
6-1	M3 Voltages Charts	6-4
6-2	Tune Voltages for -203 or -204 Software Configurations	6-8
6-3	Tune Voltages for -202 Software	6-8
6-4	Parts List, Processor Module, M3A	6-13
6-5	Parts List, Switch Module, M3B	6-17
7-1	M4 Dc Voltage Charts	7-3
7-2	M4 Filter Adjustment Coils and Frequencies	7-3
7-3	Parts List, Transmitter Module, M4	7-7
8-1	M5 Dc Voltage Levels	8-2
8-2	M5 Frequency Bands	8-3
8-3	-202 Software Varactor Settings	8-3
8-4	Parts List, Receiver Module, M5	8-7
9-1	Parts List, Display Board Module, M6	9-7
10-1	M7 Dc Voltage Levels	10-3
10-1	Parts List, Antenna-Tuner Module, M7	10-7
11-1	Parts List, Mainframe	11-5
12-1	Fault Determination Guide	12-3
B-1	Optional Accessory Equipment	B-1

This page intentionally left blank.

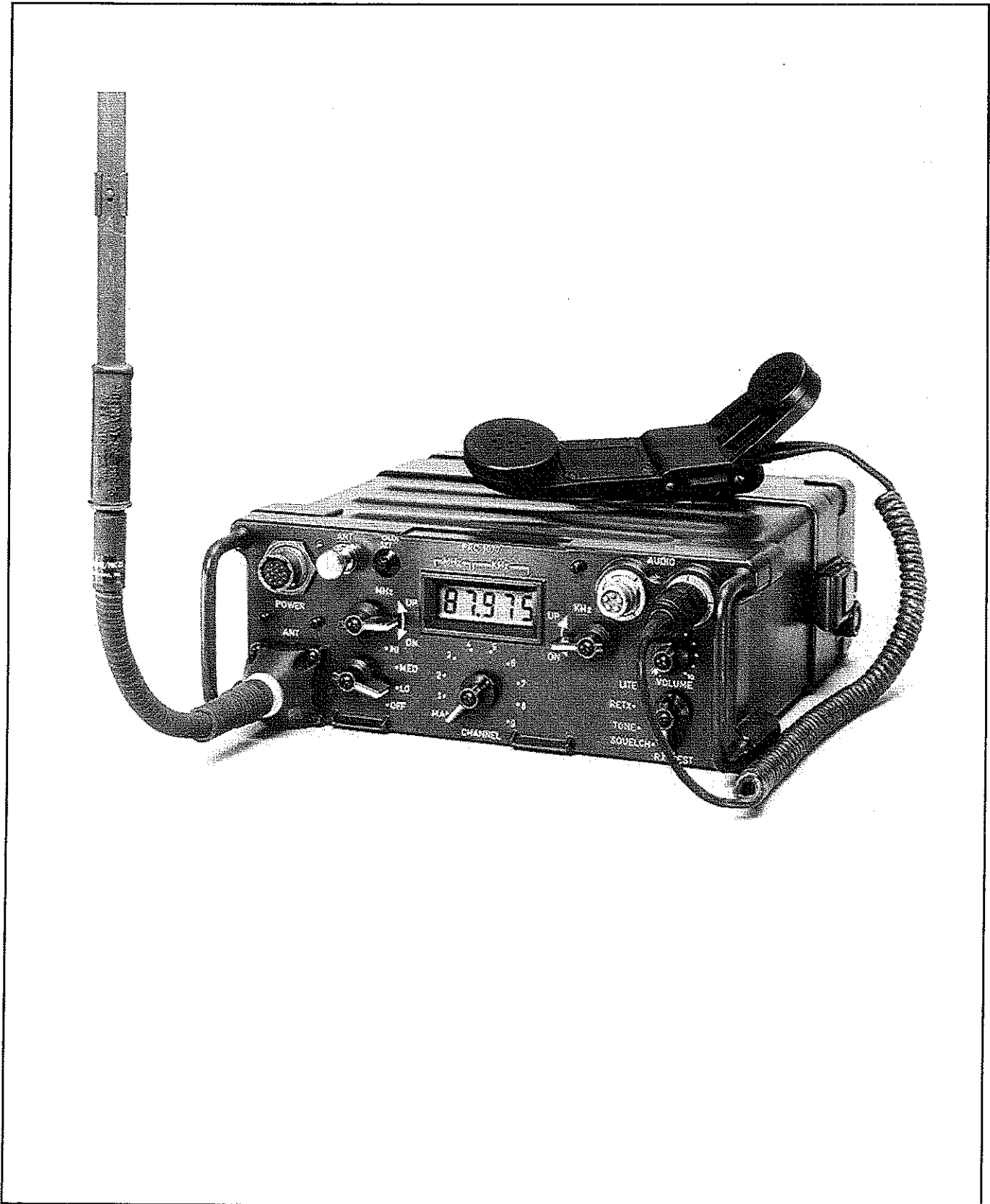

FIGURE 1-1.
30- to 88-MHz Packset Transceiver.

CHAPTER 1

INTRODUCTION & TECHNICAL SPECIFICATIONS

1-1 GENERAL

This manual provides detailed information on the service and repair of the PRC1077 transceiver. Full technical information is given including schematic diagrams, circuit descriptions, theory of operation, and test and alignment procedures. The manual also contains detailed parts lists.

1.2 OPERATOR'S MANUAL

The manual should be used in conjunction with the

operator's manual TW-PRC1077-TM1. This manual includes full installation and operating instructions and field maintenance instructions.

1-3 TECHNICAL SPECIFICATIONS

Chapter 1 contains the technical specifications in Table 1-1, semiconductors in Table 1-2, the block diagram (Figure 1-2) and the module location diagrams (Figures 1-3 and 1-4).

TABLE 1-1.
Technical Specifications.

GENERAL CHARACTERISTICS	
Frequency Range:	30-87.975 MHz continuous.
Number of Channels:	2,320.
Preset Memory Channels:	10 (field programmable).
Channel Spacing:	25 kHz.
Squelch:	150-Hz tone, or selectable noise squelch for voice.
Power Source:	Battery Pack - BA386/PRC-25, BA4386/U, BA398/U, BA5598/U Lithium "D Cell" Cassettes.
TX Power:	Selectable: 0.3 W, 2 W, 5 W, (nominal with new battery pack).
Temperature Range:	-40°C to +60°C.
Distance Range:	10 miles (16 km) - varies with conditions.
Antennas:	
Whip Antennas:	AT-892/U/PRC-25 3-ft whip. AT-271A/U/PRC 10-ft multisection whip (optional).
50-Ohm Antennas:	4242-MK1 30-88 MHz broadband vehicular antenna. AS-1729/VRC 30-76 MHz whip vehicular antenna.
Antenna Tuner:	Internal - automatic.
Modulation:	Frequency Modulation, (Phase modulation per EIAA standards).
Current Drain:	Receive: 60 mA, squelched. Transmit: 0.3 W - 800 mA, 2.0 W - 1.1 A, 5.0 W - 1.6 A.

**TABLE 1-1.
Technical Specifications, Continued.**

GENERAL CHARACTERISTICS, CONTINUED

Size (WHD):	28.2 cm X 10.4 cm X 23.5 cm.
Weight:	Unit + 3 ft antenna - 4.8 kg, Battery case & alkaline battery - 1.6 kg.

TRANSMITTER

Power Output:	Low Position: 300 mW. Medium Position: 2 W. High Position: 5 W.
Frequency Stability:	20 ppm -40° C to + 60° C.
Deviation:	Preset to ±10 kHz.
Audio Bandwidth:	16 kHz wideband data input; 3 kHz voice.
Modulation Limiting:	Ref +20 dB from 3 kHz deviation at 1000 Hz tone input: ±10 kHz deviation maximum, 100 - 20,000 Hz.
Distortion:	5 %.
Noise and Hum:	-40 dBc.
Adjacent Channel Noise:	-50 dBc.
Spurious Outputs (non-harmonic):	-60 dBc typical.
Harmonics:	-46 dBc.
Audio Input:	Voice: 1.5 mV for 60% max deviation. Data : 0.77 V at 600 ohms for ±5 kHz.
RF Bandwidth:	Continuous 30-87.975 MHz.
Types of Transmission:	Voice (300-3,500 Hz) and 150-Hz squelch tone (selectable is optional).

RECEIVER

Sensitivity:	0.35 μV for 12 dB SINAD.
Squelch Threshold:	less than or equal to 0.35 μV.
RF Bandwidth:	Continuous 30-87.975 MHz.
Adjacent Channel Selectivity:	-70 dB.
Spurious Responses:	-70 dB.
Intermodulation:	-70 dB at maximum sensitivity.

TABLE 1-1. Technical Specifications, Continued.

RECEIVER, CONTINUED

Audio Output:	Voice:	0.5 W, 16 ohms.
		0.05 W, 150 ohms.
	Data:	0.77 V RMS into 600 ohms.
Receiver Bandwidth:		30 kHz \pm 10 kHz deviation.
Audio Bandwidth:	Voice:	3 kHz.
	Data :	15 kHz.
Distortion:		10 %.
Hum and Noise:		-40 dB @ 30 μ V signal input.
Types of Reception:		Voice - no squelch, 150-Hz tone squelch, or noise squelch.

TABLE 1-2. Semiconductors.

Designator	Function	Description
M1D1	Voltage Protection	1N4148 Diode
M1D2	Isolation Diode	1N4148 Diode
M1D3	Tone Detector	1N4148 Diode
M1Q1	Squelch Switch	MP5D54 Darlington Transistor
M1Q2	Receive Audio Disable	2N3567 NPN Transistor
M1Q3	Sidetone Audio Disable	J175 Transistor
M1Q4	High Impedance Buffer	2N3567 NPN Transistor
M1Q5	RETX PTT Switch	2N3567 NPN Transistor
M1Q6	Audio Disable Switch	2N3567 NPN Transistor
M1Q7	Active Filter Amp	2N6427 Darlington Transistor
M1U1	MIC Amp, Limiter, Filter	LM393N Integrated Circuit
M1U2	Summing Amp, Mod Control	LF442CN Integrated Circuit
M1U3	Audio Amp, Regulator	LF442CN Integrated Circuit
M1U4	Modulation Gain Control	MM74C906N Integrated Circuit
M1U5	Modulation Gain Register	CD4094BE/MC14094BCP Integrated Circuit
M1U6	Speaker Amplifier	LM386N-1 Integrated Circuit
M1U7	Commutating Filter	CD4052BE Integrated Circuit
M1U8	Divider	CD4029 Integrated Circuit
M1U9	Filter, Tone Detector	LF442CN Integrated Circuit
M1U10	Squelch Logic	CD4011 Integrated Circuit
M2D1	Band 1 Switch	BA482 PIN Diode
M2D2	Band 2 Switch	BA482 PIN Diode
M2D3	Band 3 Switch	BA482 PIN Diode
M2D4	Band 4 Switch	BA482 PIN Diode
M2D5	Band 1 Filter Switch	BA482 PIN Diode
M2D6	Band 2 Filter Switch	BA482 PIN Diode
M2D7	Band 3 Filter Switch	BA482 PIN Diode
M2D8	Band 4 Filter Switch	BA482 PIN Diode
M2D9	Band 1 Filter Switch	BA482 PIN Diode
M2D10	Band 2 Filter Switch	BA482 PIN Diode
M2D11	Band 3 Filter Switch	BA482 PIN Diode
M2D12	Band 4 Filter Switch	BA482 PIN Diode
M2D13	TX Switch	BA482 PIN Diode
M2D14	RX Switch	BA482 PIN Diode
M2D15	Band 1 Frequency Control	MV209 Diode
M2D16	Band 2 Frequency Control	MV209 Diode
M2D17	Band 3 Frequency Control	MV209 Diode
M2D18	Band 4 Frequency Control	MV209 Diode
M2D19	PTT Isolation	1N4148 Diode
M2Q1	Loss Of Lock Detect	PN2907A PNP Transistor
M2Q2	Voltage Regulator Pass XSTR	PN2907A PNP Transistor
M2Q3	Band 1 Switch	PN2907A PNP Transistor
M2Q4	Band 2 Switch	PN2907A PNP Transistor
M2Q5	Band 3 Switch	PN2907A PNP Transistor
M2Q6	Band 4 Switch	PN2907A PNP Transistor
M2Q7	Band Decoder	2N3565 NPN Transistor
M2Q8	Band 1 Level Shift	2N3565 NPN Transistor
M2Q9	Band 2 Level Shift	2N3565 NPN Transistor
M2Q10	Band 3 Level Shift	2N3565 NPN Transistor
M2Q11	Band 4 Level Shift	2N3565 NPN Transistor

TABLE 1-2. Semiconductors, Continued.

M2Q12	Band 1 Oscillator	3N204 MFT Transistor
M2Q13	Band 2 Oscillator	3N204 MFT Transistor
M2Q14	Band 3 Oscillator	3N204 MFT Transistor
M2Q15	Band 4 Oscillator	3N204 MFT Transistor
M2Q16	Combining Amplifier	MRF904 NPN Transistor
M2Q17	Output Amplifier	MRF904 NPN Transistor
M2Q18	RX Switch Driver	2N3565 NPN Transistor
M2Q19	TX Switch Driver	2N3565 NPN Transistor
M2Q20	Isolation Amplifier	MRF904 NPN Transistor
M2Q21	Phase Detector Amplifier	3N204 MFT Transistor
M2Q22	Phase Detector Amplifier	2N3565 NPN Transistor
M2Q23	Phase Detector Amplifier	2N3638 PNP Transistor
M2U1	Synthesizer Divider/Detector	MC145156P Integrated Circuit
M2U3	Voltage Regulator	LM358N Integrated Circuit
M2U4	Dual Modulus Prescaler	DS8615N-4 Integrated Circuit
M2U5	Voltage Reference	LM336Z-5.0 Integrated Circuit
M3AQ1	ROM Switch	PN2907A PNP Transistor
M3AU1	Microprocessor	80C39 Integrated Circuit
M3AU2	Parity Tree	MC14531 Integrated Circuit
M3AU3	Dual Monostable	MC14528BCP Integrated Circuit
M3AU4	Address Latch	74HCT573 Integrated Circuit
M3AU5	Output Latch	74HC574N Integrated Circuit
M3AU6	ROM	UPD2716-6 Integrated Circuit
M3BD1	Spike Suppressor	1N4148 Diode
M3BD2	Dc Voltage Combiner	1N4148 Diode
M3BD3	Dc Voltage Combiner	1N4148 Diode
M3BD4	Voltage Limiter	1N756 Zener Diode
M3BD5-M3BD7	Dc Voltage Doubler	1N4148 Diode
M3BQ1	Transmit & Voltage Switch	PN2907A PNP Transistor
M3BQ2	Transmit Switch Inhibit	2N3565 NPN Transistor
M3BQ3	Transmit Switch	2N3565 NPN Transistor
M3BQ4	Low Voltage Detector	2N3565 NPN Transistor
M3BQ5	Reset Switch	2N3565 NPN Transistor
M3BQ6	Band Decoder	2N3565 NPN Transistor
M3BQ7	Voltage Regulator Buffer	2N3565 NPN Transistor
M3BQ8	RAM Dc Switch	2N3565 NPN Transistor
M3BQ9	Band 1 Switch	PN2907A PNP Transistor
M3BQ10	Band 2 Switch	PN2907A PNP Transistor
M3BQ11	Band 3 Switch	PN2907A PNP Transistor
M3BQ12	Band 4 Switch	PN2907A PNP Transistor
M3BQ13	Band 1 Level Shifter	2N3565 NPN Transistor
M3BQ14	Band 2 Level Shifter	2N3565 NPN Transistor
M3BQ15	Band 3 Level Shifter	2N3565 NPN Transistor
M3BQ16	Band 4 Level Shifter	2N3565 NPN Transistor
M3BQ17	Voltage Reference	LM336Z-5.0 Integrated Circuit
M3BQ18	+5 V Pull Down	J175 Transistor
M3BQ19	Dc Voltage Doubler	2N6427 Darlington Transistor
M3BQ20	Dc Voltage Doubler	2N3565 NPN Transistor
M3BU1	600 Hz Oscillator/Divider	CD4060AE Integrated Circuit
M3BU2	+5 V Regulator/ D To A	LM358N Integrated Circuit
M3BU3	Storage Register	CD4094/MC14094BCP Integrated Circuit

TABLE 1-2. Semiconductors, Continued.

M4D1-M4D16	Steering Diode	1N4148 Diode
M4Q1	RF Amplifier	MRF904 NPN Transistor
M4Q2	Driver Amplifier	2N3866 NPN Transistor
M4Q3	Power Amplifier	SD1127 NPN Transistor
M4Q4, M4Q5	Latch Inverter	2N3567 NPN Transistor
M5D1	Band 1 Switch	BA482 PIN Diode
M5D2-M5D9	Band 1 Tuning Diode	MV209 Diode
M5D10	Band 1 Switch	1N4148 Diode
M5D11	Band 2 Switch	BA482 PIN Diode
M5D12-M5D15	Band 2 Tuning Diode	MV209 Diode
M5D16	Band 2 Switch	1N4148 Diode
M5D17	Band 3 Switch	BA482 PIN Diode
M5D18-M5D21	Band 3 Tuning	MV209 Diode
M5D22	Band 3 Switch	1N4148 Diode
M5D23	Band 4 Switch	BA482 PIN Diode
M5D24-M5D27	Band 4 Tuning	MV209 Diode
M5D28	Band 4 Switch	1N4148 Diode
M5D29	Noise Detector	1N4148 Diode
M5D30	Voltage Regulator	1N756 Zener Diode
M5Q1	Band 1 RF Amplifier	MRF904 NPN Transistor
M5Q2	Band 2 RF Amplifier	MRF904 NPN Transistor
M5Q3	Band 3 RF Amplifier	MRF904 NPN Transistor
M5Q4	Band 4 RF Amplifier	MRF904 NPN Transistor
M5Q5	1st Mixer	3N204 MFT Transistor
M5Q6	IF Buffer Amplifier	3N204 MFT Transistor
M5Q7	Squelch Signal Switch	2N3565 NPN Transistor
M5Q8	Voltage Regulator	2N3565 NPN Transistor
M5U1	FM Subsystem IC	MC3357P Integrated Circuit
M6CR1-M6CR4	Steering Diode	1N4148 Diode
M6Q1	Backlight Driver	2N3567 NPN Transistor
M6Q2	Alarm Clamp (Lo. Batt.)	PN2222A NPN Transistor
M6Q3	Backlight Driver	2N6427 NPN Darlington Transistor
M6Q6	Option	2N6427 NPN Darlington Transistor
M6U1	Display Driver	MD4332B Integrated Circuit
M6U2	Backplane Generator	CD4060AE Integrated Circuit
M6U3	Voltage Detector	RE5VA21AC Integrated Circuit
M6U4	L. Batt. Alarm/Backlight Delay	CD4093 Integrated Circuit
M7D1-M7D16	Steering Diode	1N4148 Diode
M7D17	RF Detector	1N34A Diode
M7Q1	Latch Inverter	2N3565 NPN Transistor
M7Q2	Latch Driver	2N3565 NPN Transistor
M7Q3	Latch Inverter	PN2907A PNP Transistor
M7Q4	Latch Driver	PN2907A PNP Transistor
M7Q5	L1 Relay Selector	2N3565 NPN Transistor
M7Q6	L2 Relay Selector	2N3565 NPN Transistor
M7Q7	L3 Relay Selector	2N3565 NPN Transistor
M7Q8	C1 Relay Selector	2N3565 NPN Transistor

TABLE 1-2. Semiconductors, Continued.

M7Q9	L4 Relay Selector	2N3565 NPN Transistor
M7Q10	L5 Relay Selector	2N3565 NPN Transistor
M7Q11	C4 Relay Selector	2N3565 NPN Transistor
M7Q12	C3 Relay Selector	2N3565 NPN Transistor
M7Q13	RF Detector Switch	2N3565 NPN Transistor
M7U1	Antenna Tuner Storage Register	CD4094BE/MC14094BCP Integrated Circuit

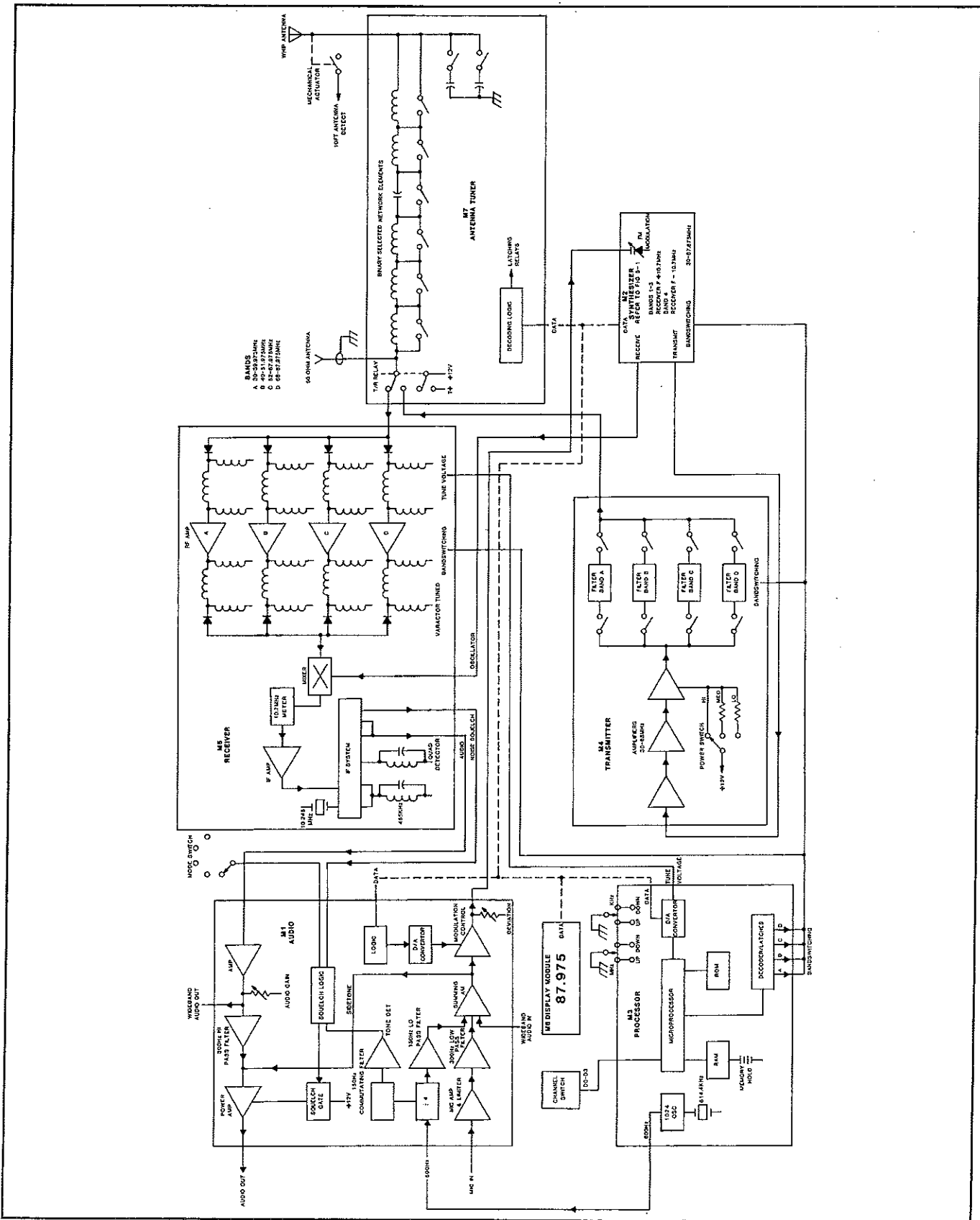
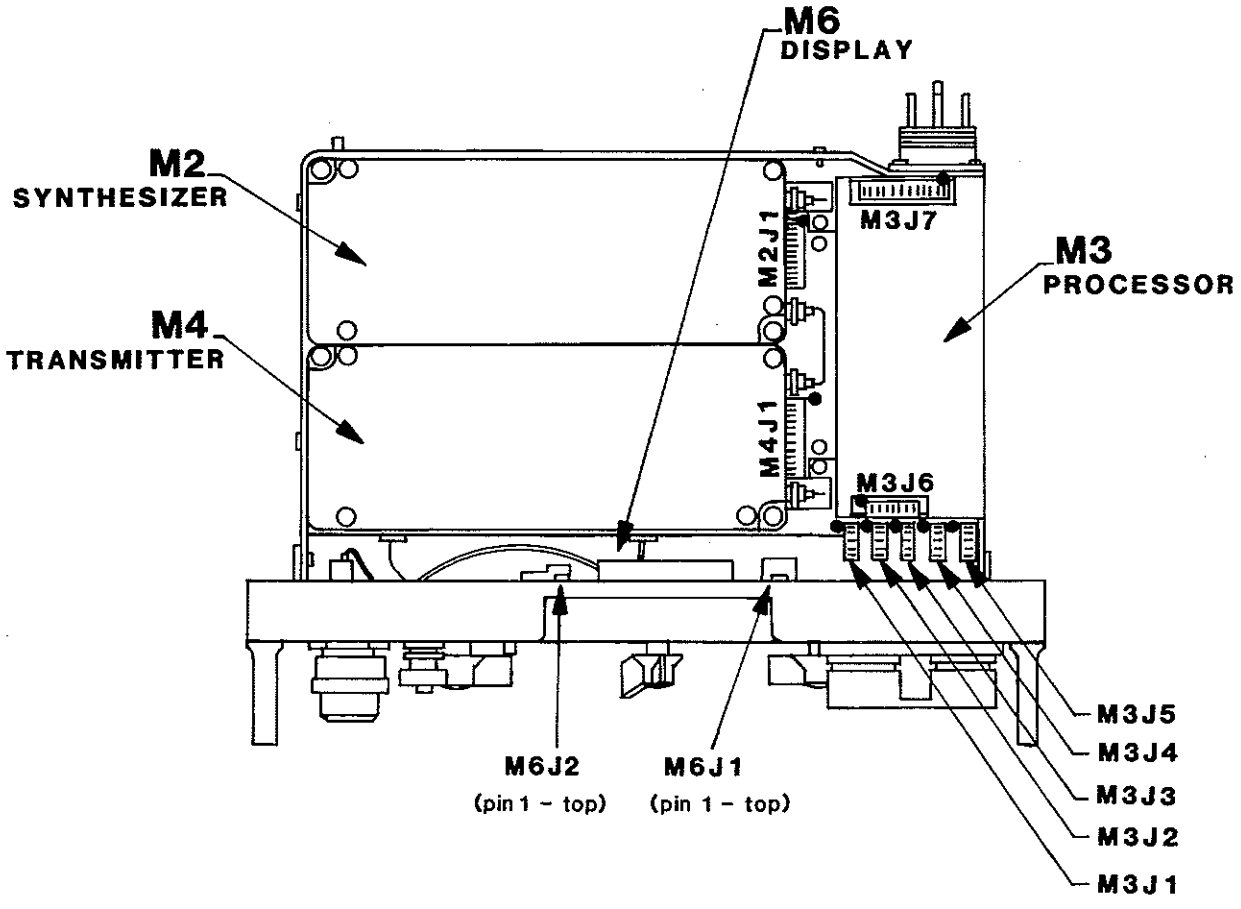
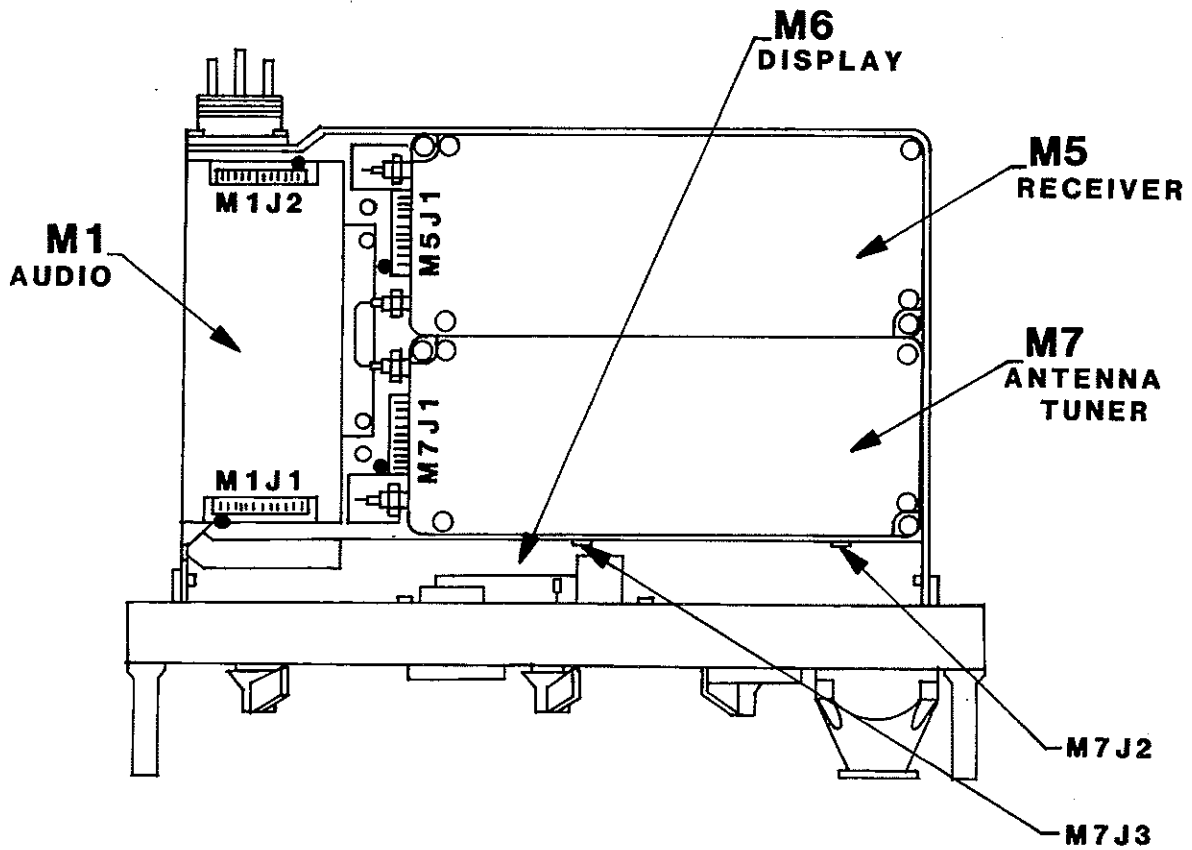

FIGURE 1-2.
Block Diagram.



NOTE: "•" next to connector=pin 1 location

FIGURE 1-3.
Module Locations - Top.



NOTE: "•" next to connector=pin 1 location

FIGURE 1-4.
Module Locations - Bottom.

CHAPTER 2 SERVICE & MAINTENANCE

2-1 SCOPE

This chapter provides information on the routine maintenance of the transceiver, methods for locating and replacing defective modules, and a description of recommended test equipment. For in-depth information on the individual modules, reference should be made to Chapters 4-10 of this manual.

2-2 GENERAL

The PRC1077 is a complex transceiver using advanced design techniques to ensure high performance and trouble-free service. Although operators can perform most maintenance procedures, the transceiver must be serviced by skilled personnel using the correct test equipment. To ease repairs and minimize downtime, all complex circuitry is contained on individual, field-replaceable modules. These in turn are designed so that no adjustments are required

after replacement. Defective modules can be repaired at the service depot or sent back to the factory.

2-3 OPERATOR'S (PREVENTIVE) MAINTENANCE

Preventive maintenance is the systematic care and inspection of the equipment to prevent the occurrence of trouble, and to ensure that the equipment is serviceable. No tools or test equipment are required for these operations.

2-3.1 SYSTEMATIC CARE

The procedures found in Tables 2-1 and 2-2 are essential to proper upkeep and operation of the equipment. Both the daily and weekly checks must be performed before and during operation, and after shutdown. If the equipment is being maintained in a standby condition, both the daily and weekly checks should be accomplished concurrently. Defects that cannot be remedied by the operator will require higher-level maintenance or repair.

TABLE 2-1.
Operator's Daily Preventive Maintenance Checks and Services Chart.

Sequence Number	Item to Be Inspected	Procedure	Reference
1	Completeness	Check to see that the equipment is complete.	Sec. 2-3.2
2	Exterior Surfaces	Remove dust, dirt and moisture from all surfaces and clean frequency window with a soft cloth.	Sec. 2-3.3
3	Controls	a. Check all controls for looseness or damage. b. During the operational check, check the mechanical action of each control for smooth operation.	Table 2-3
4	Battery	Inspect for leakage, corrosion and swelling. WARNING: Remove battery when transceiver is not to be used for one or more days.	Fig. 2-1 Sec. 2-4.5
5	Tuning	Perform the steps in operational check list.	Table 2-3

TABLE 2-2.
Operator's Weekly Preventive Maintenance Checks and Services Chart.

Sequence Number	Item to Be Inspected	Procedure	Reference
1	Handset	Inspect the cable for fraying, cuts, kinks and broken insulation.	Fig. 2-3
2	Cloth Items	Inspect for fraying and tears.	Fig. 2-1
3	Antenna	Inspect for damage, loose fit, and corrosion.	Fig. 2-1
4	Gasket	Inspect the gasket on the battery box for damage.	Sec. 2-4.5

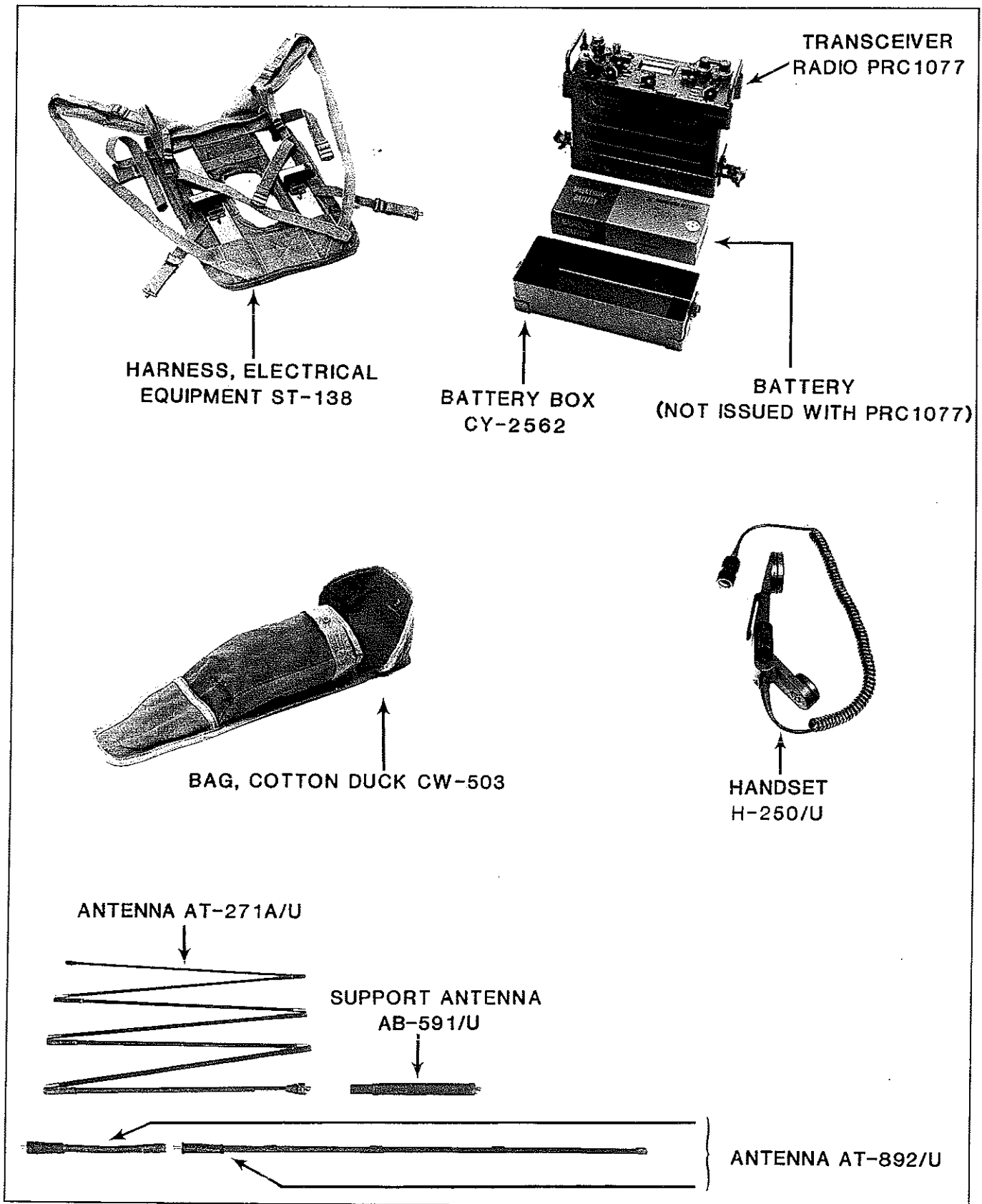

FIGURE 2-1.
 Radio Set PRC1077, Manpack Components.

2-3.2 COMPLETENESS OF ACCESSORIES

The following components are normally used with the PRC1077 in the manpack configuration (refer to Figure 2-1):

1. Radio Set PRC1077 (includes battery box).
2. Battery BA-4386/U or equivalent.
3. Antenna AT-271A/U.
4. Antenna AT-892/U.
5. Bag, Cotton Duck CW-503.
6. Handset H-250/U.
7. Harness, Electrical Equipment ST-138.
8. Support, Antenna AB-591/U.

2-3.3 CLEANING

The following operations should be performed daily when the equipment is in use, and weekly during standby conditions.

1. Remove dust and loose dirt with a clean, soft cloth.
2. Remove grease, fungus and ground-in dirt from the case using a cloth dampened with trichlorethane.
3. Remove dust and dirt from plugs and receptacles.
4. Clean the panel and the control knobs using a soft

clean cloth. If the dirt is difficult to remove, dampen the cloth with mild detergent and water.

CAUTION!

Trichlorethane vapors are toxic and combustible. Provide adequate ventilation.

2-3.4 MALFUNCTION - VISUAL INSPECTION

1. If the radio does not operate correctly, check the following items:
 - (a) Switches and controls for correct setting.
 - (b) Handset (check by substitution).
 - (c) Antenna connection.
 - (d) Battery dead (check by substitution).

2. If these checks do not locate the problem, proceed to Section 2-3.5.

2-3.5 OPERATIONAL CHECKLIST.

The checklist in Table 2-3 will help the operator locate the problem quickly and offers simple corrective measures. If these do not work, repair is required at a higher maintenance category. Make sure that a tag is attached to the transceiver reporting the nature of the problem.

Procedure

Connect a handset to either audio connector and install the antenna. Perform the steps given in Table 2-3.

**TABLE 2-3.
PRC1077 Operational Checklist.**

Step	Action	Normal Indication	Corrective Measure
1	Set the VOLUME control to 5.		
2	Set CHANNEL switch to check channel.		
3	Set POWER switch to HIGH.	Channel frequency is displayed.	Reset frequency (Operators Manual Sec. 3-2).
4	Set and hold FUNCTION switch at LITE.	Display lights.	a. Check that cover is on power connector. b. Replace battery (Sec. 2-4.5).
5	Set FUNCTION switch to RX TEST.	Rushing noise is heard.	Higher level maintenance required.
6	Set FUNCTION switch to TONE.	Rushing noise stops.	Higher level maintenance required.
7	Listen to test signals from a nearby set operating on the same frequency.	Signals are heard loud and clear.	Check antenna.
8	Transmit test signal to a nearby set operating on the same frequency.	Signals are heard loud and clear.	Connect handset to other audio connector.
9	Check frequencies of channels 1-9.	Correct frequencies are shown in display.	Reset frequency (Operator's Manual Sec. 3-2).

2-4 FIELD MAINTENANCE

This section covers the field maintenance of the PRC1077, which is of a higher level than the preventive maintenance found in Section 2-3. A series of tests is outlined to ensure that the transceiver and accessories are operating correctly. This chapter does not contain information on the replacement and repair of the internal modules; reference should be made to Sections 2-5 and 2-6, Field and Depot Service.

2-4.1 TOOLS AND ACCESSORIES REQUIRED

1. Bird Model 43 Thru-line wattmeter with 10-W element (or equivalent).

NOTE: Ensure element is of the correct frequency range or power measurement errors may occur.

2. Bird Model 8321 50-W dummy load (or equivalent).

3. Screwdrivers - #1 and #2 Phillips, and medium flat blade.

4. 5/16" open-end wrench.

5. Cleaning materials.

6. A complete set of operating accessories.

2-4.2 MAINTENANCE INTERVALS

The maintenance interval will be determined by the type of usage. Equipment in daily use under harsh environmen-

tal conditions requires maintenance at intervals of one month or less. Under light service, the maintenance schedule should be performed at least on a quarterly basis.

2-4.3 FIELD MAINTENANCE CHECKLIST

Refer to Table 2-4, following the prescribed sequence in order.

2-4.4 PERFORMANCE CHECKS

IMPORTANT!

Before starting the performance checks, it is important to understand the operation of the BA-4386/U magnesium battery. This battery is unconventional in that the output voltage can vary substantially with the time of use and load conditions.

Typically, an unloaded battery will have a terminal voltage of 12 V. When the transceiver is first switched on, it may fall to 6 V and then gradually build back up to 12 V or more. This will result in the receiver operating for a few seconds, then stopping until the battery voltage recovers. During this period the frequency display may operate incorrectly.

TABLE 2-4.
Field Maintenance Checklist.

Sequence Number	Item to Be Inspected	Procedure	References
1	Completeness	Check to see the transceiver is complete with all accessories.	Sec. 2-3.2
2	Cleanliness	Check to see that the transceiver is clean.	Sec. 2-3.3
3	Preservation	Check all surfaces for rust, corrosion and fungus. Remove and spot paint any bare spots on metal surfaces.	
4	Operational Test	Perform all tests in performance checklist.	Sec. 2-3.5
5	Controls	Check that all controls work smoothly, do not bind, and that the knobs are tight on the shafts.	Fig. 2-3
6	Cables	Inspect the handset cable for fraying, cuts and damage.	Fig. 2-3
7	Cloth	Inspect all cloth items for tears, fraying and deterioration.	Fig. 2-1
8	Antennas	Inspect the antennas for damage, loose fit and corrosion.	Fig. 2-1
9	Display	Check the frequency display window for cleanliness.	Sec. 2-3.3
10	Internal	Remove chassis from case and blow out to remove any possible gas accumulation from the magnesium battery.	Sec. 2-4.5
11	Modules	Check that the connectors are in place on all modules.	Sec. 2-4.5
12	Seals	Inspect the seals on the transceiver panel, battery box and battery connector.	Sec. 2-4.5

In the transmit mode the transceiver draws a considerable amount of current, and the battery voltage may again fall and gradually rise to a peak of 14-16 V. If the transmitter power output is measured during this cycle, the level may fall as low as 0.5 W and slowly rise to 8 W or more.

These characteristics are most noticeable with a new battery or one that has not been in use for some time. Normal battery characteristics can be quickly achieved by holding the transceiver in the HI power transmit mode for two or three minutes before starting operations.

NOTE

Many of the following checks are made between two transceivers. Both units should be set to LO power in order to limit the range of the equipment. Adjust the distance between the transceivers so that they are close to maximum range. (Use two known good transceivers to set the maximum distance between transceivers, for a unit with low transmitter output or poor sensitivity may check out satisfactorily at close range). Controls of the CHECK transceiver should always be set exactly the same as the transceiver being TESTED.

Procedure:

1. Accessories

- (a) Install the desired antenna in the antenna mount.
- (b) Connect handset to either audio connector.

2. Controls - set as follows:

- (a) VOLUME - set to 5.
- (b) POWER - set to LO.
- (c) FUNCTION - set to RX TEST.
- (d) CHANNEL - set to MAN.
- (e) Enter a test frequency into the MAN channel.

At this point the frequency should be displayed and there should be a rushing noise in the handset. If these indications are not correct:

- (a) Tighten power receptacle cap.
- (b) Connect handset to other audio connector.
- (c) Check handset by substitution.
- (d) Replace battery.

3. Operating Check

- (a) Ensure CHECK transceiver is operating on the same frequency as the TEST transceiver.
- (b) Reception Test: When the CHECK transceiver makes a transmission, the signal should be heard loud and clear.
- (c) Transmission Test: When the TEST transceiver makes a transmission, the signal should be heard loud and clear. (Change the handset if a signal is present without transmit audio.)

4. Band Check

The PRC1077 has four internal frequency bands selected automatically by the microprocessor. The following test ensures that the transceiver is operating on all bands.

- (a) Repeat test 3 above on any frequency 30-39.975 MHz.
- (b) Repeat test 3 above on any frequency 40-51.975 MHz.
- (c) Repeat test 3 above on any frequency 52-67.975 MHz.
- (d) Repeat test 3 above on any frequency 68-87.975 MHz.

NOTE

The original test frequency will be in one of the four ranges and the test in this range need not be repeated.

5. Squelch Check

- (a) Set the TEST transceiver FUNCTION switch to SQUELCH. The receiver should mute.
- (b) The CHECK transceiver makes a transmission.
- (c) The signal should be received loud and clear.

6. Tone Squelch Check

- (a) Set the FUNCTION switches of both units to TONE.
- (b) The CHECK transceiver makes a transmission.
- (c) The signal should be received loud and clear.
- (d) The TEST transceiver makes a transmission.
- (e) The signal should be received loud and clear.

7. Light Test

- (a) Turn the FUNCTION switch on the TEST unit to LITE.
- (b) The frequency display should be lit.

8. Power Output Test

- (a) Remove the antenna.
- (b) Connect the wattmeter to the BNC antenna connector.
- (c) Set the frequency to 39 MHz.
- (d) Set the power switch to HI and press the push-to-talk switch. Measure output power.
- (e) Repeat step "d" at MED power.
- (f) Repeat step "d" at LO power.

The nominal power output is:

HI	5.0 W, -1.5, +2.0 dB
MED	2.0 W, -1.0, +1.5 dB
LO	0.3 W, -1.0, +2.0 dB

NOTE

Low output power may be caused by low battery voltage. Refer to the comments at the beginning of Section 2-4.4.

The test frequency of 39 MHz is chosen to minimize loading effects of the built-in antenna tuner. Testing at other than 39 MHz may result in considerable variation in output power, which is a normal condition. Since the transmitter is of broadband design, correct power output at the test frequency indicates correct operation across the entire frequency range.

9. Memory Check

- (a) Switch the transceiver channel switch through channels 1-9.
 - (b) The correct frequencies should be displayed.
- The PRC1077 uses a small internal battery (good for 10 years) to store the channel frequencies. In the event of a memory battery failure the transceiver remains operable

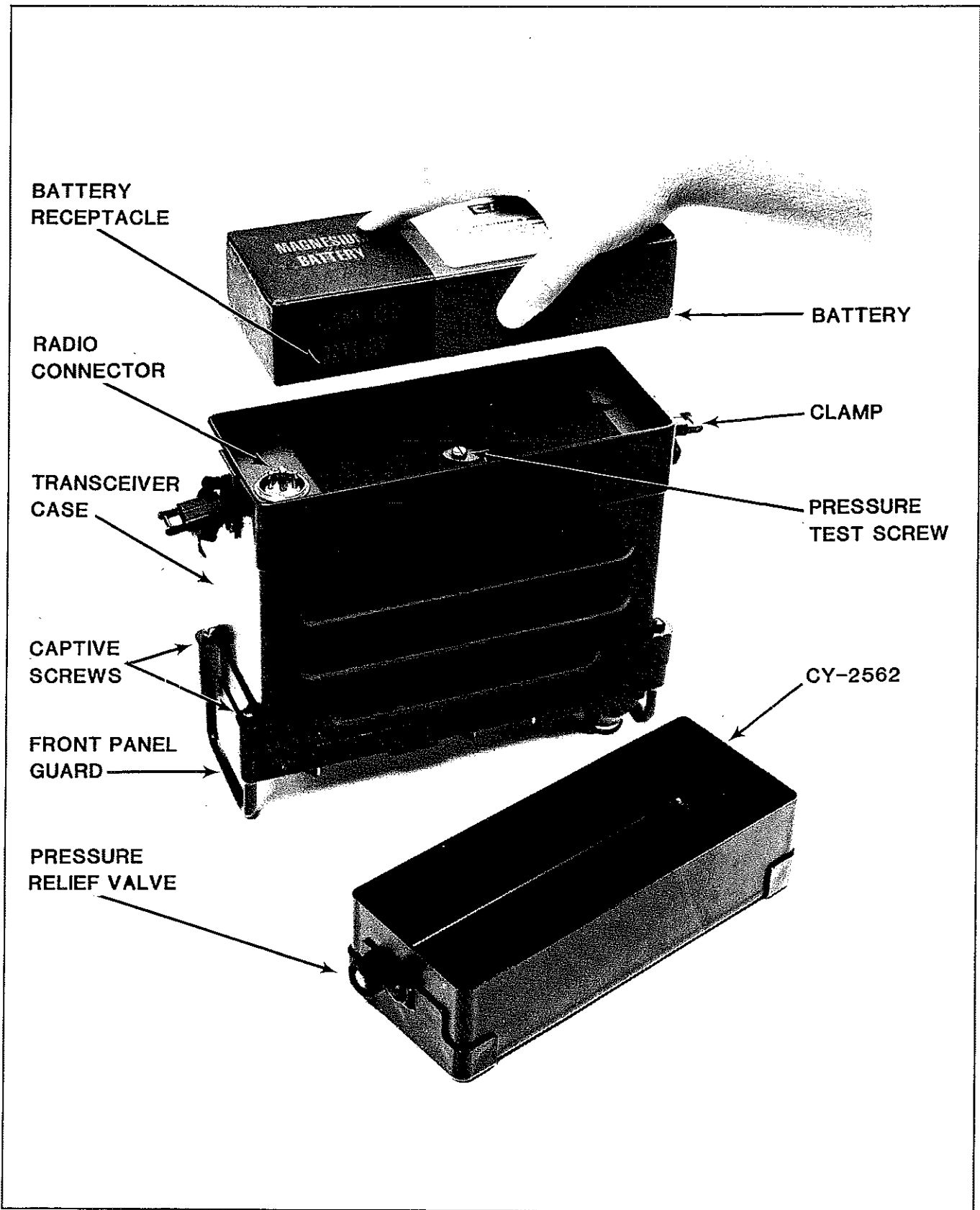
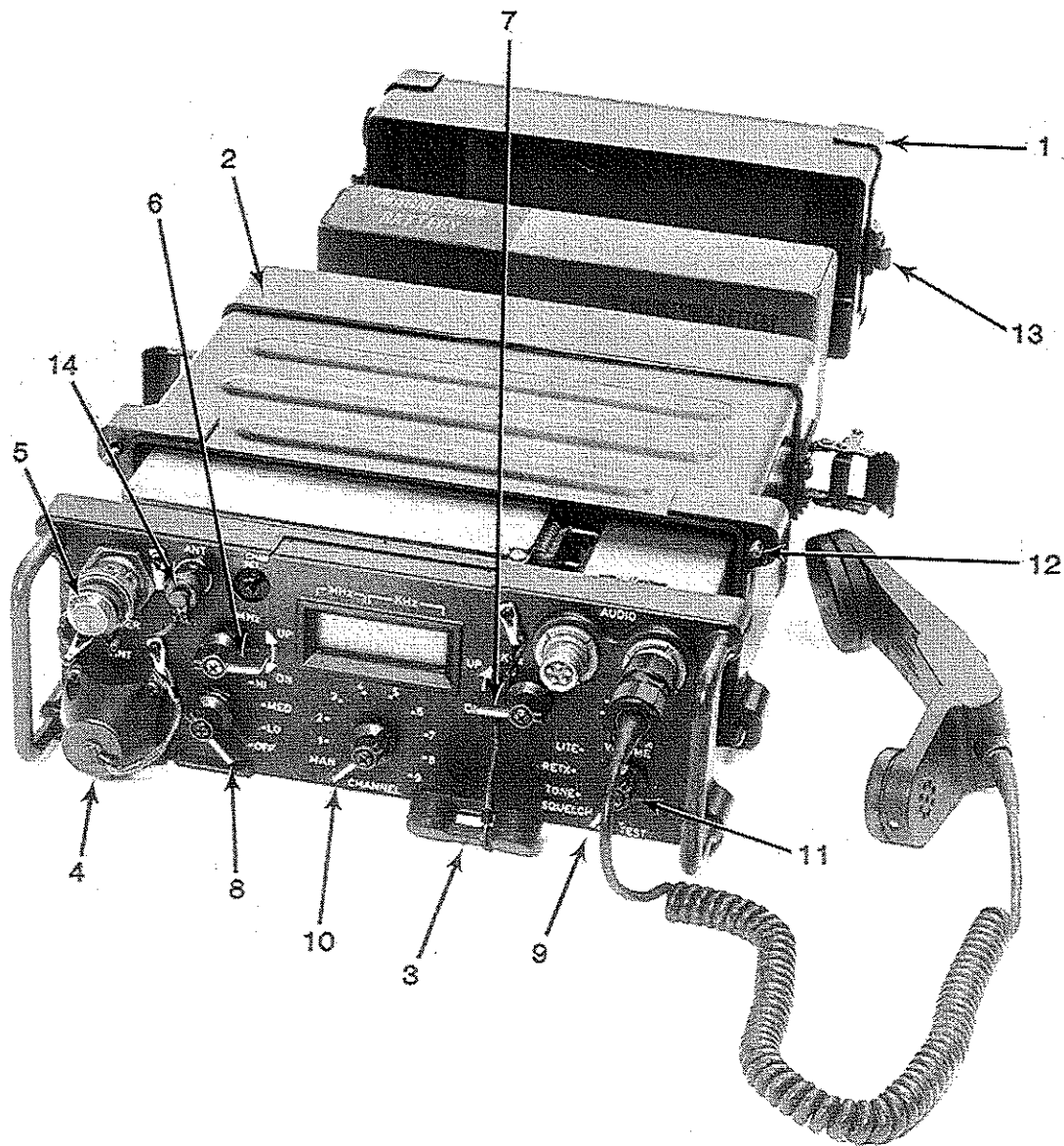

FIGURE 2-2.
Installation and Removal of Battery in Transceiver.



- | | |
|--|--|
| 1. CY-2562. | 8. Knob, long-handled (power switch). |
| 2. Case, transceiver. | 9. Knob, long-handled (function switch). |
| 3. Cover, double rubber connector protector. | 10. Knob, long-handled (channel switch). |
| 4. Cover, antenna dust. | 11. Knob (VOLUME). |
| 5. Dummy connector plug. | 12. Screw, captive. |
| 6. Knob, long-handled (MHz tuning). | 13. Hook. |
| 7. Knob, long-handled (kHz tuning). | 14. Cover, 50-ohm RF antenna, BNC. |

FIGURE 2-3.
Receiver/Transmitter, Radio Set PRC1077, Organizational Repair Parts.

but will not retain memory when the main battery is removed.

2-4.5 INTERNAL INSPECTION

1. Stand the transceiver on the front panel (Figure 2-2). Remove the battery case and the battery. Loosen the captive screws and pull the case from the chassis (Figure 2-3). If the case will not break free, CAREFULLY insert a small-tip screwdriver between the case and front panel in the areas OUTSIDE of the captive screws and pry it open. Be careful to not damage the fragile rubber seal installed on the mating surfaces.

2. Using your breath, blow out all parts on both sides of the chassis. This will remove any excess hydrogen gas from the magnesium battery that may have accumulated in the chassis.

3. Inspect the battery connector for the following:

(a) The two O-rings on the battery connector must be in place and uncut. Each O-ring must be sealed under tension in its recess.

(b) The three battery connector pins must not be bent or otherwise damaged.

4. Inspect the connectors on all transceiver modules. Ensure that all in-line connectors are locked firmly in place, and that all hex nuts on the coaxial connectors are secure.

5. Inspect the seals on the front panel and the base of the transceiver. They should be clean and free from cuts or nicks to ensure waterproof service. The top edge of the case and the battery box must be smooth and free from dents or nicks.

6. The pressure test screw in the battery box must be securely sealed. This hole is used for pressure testing of the case during manufacturing.

7. Check that the pressure relief valve is screwed tightly in place. This valve will vent hydrogen gas generated by the magnesium battery.

TABLE 2-5.
General Fault-Location Chart.

SYMPTOM	MODULE/COMPONENT TO REPLACE
1. Radio dead—no TX, RX, or display.	Main battery or M3
2. Channel programming is lost when radio is turned off.	Lithium backup battery
3. Weak or no audio or TX sidetone.	Handset or M1
4. No RX audio or static, but TX sidetone is present.	M1
5. No RX signals, but faint static is present.	M5
6. Carrier or tone squelch not opening or closing.	M1 or M5
7. No TX audio, but carrier power OK.	Handset or M1
8. Weak or distorted TX audio.	M1
9. No or low TX carrier output.	M4 or M7
10. No TX and RX, but display OK.	M2
11. Low TX output and poor RX sensitivity.	M7
12. No TX sidetone, but radio otherwise OK.	M1 or M7
13. Display garbled or dead, but radio otherwise OK.	M3 or M6
14. Radio not on indicated frequency.	M2
15. Difficulty in frequency programming or tuning.	M3

2-5 FIELD SERVICE

Field-level service is used to repair a radio in the absence of test equipment. Repairs are achieved by isolation and subsequent replacement of a defective module or modules. Field service can generally be performed by unskilled operators, although it is advisable that skilled technicians be employed whenever possible.

2-5.1 BASIC MODULE FAULT LOCATION

This section will assist in locating faulty modules without the use of test equipment. However, before replacing any modules, carefully inspect all cables and connections. A broken wire or a loose connector may prevent the transceiver from operating.

Use Tables 2-5 and 2-6 to try and isolate the fault, keeping in mind that some conditions cannot be determined with this approach. If unsuccessful, systematically replace each module until the faulty one is located. When modules are replaced, it is usually not necessary to make any adjustments or to realign the transceiver.

2-5.2 ACCESS & MODULE REMOVAL

Case Removal

Refer to Section 2-4.5 to separate the case from the front panel.

Removal of M1 Module

Remove the two screws on the exterior of the case that holds the module to the main chassis. Loosen the two screws holding the interior flange of the module cover. Disconnect the plugs from J1 and J2. Remove the module.

Removal of M2, M4, and M5 Modules

Detach the top cover by removing the four flathead screws attaching it. Lift the 10-pin connector assembly out of the module and separate the male (module) side from the female (wiring harness) side. Swing the male connector up and away from the module, which exposes the coaxial connectors. Use a 5/16" ignition wrench to loosen the connectors. Remove the two round-head screws holding the module to the center plate. Lift the rear of the module and slide it away from the coaxial connections.

Removal of M3 Module

Remove the two screws on the exterior of the case holding the module to the main chassis. Loosen the two screws holding the interior flange of the M1 module cover. Disconnect the plugs from J1-J7. Remove the module.

Removal of M7 Module

Detach the top cover by removing the four flathead screws attaching it. Unplug the single wire connected to antenna mount J2. Unplug the two pins connecting the coaxial cable to the board. Proceed as with modules M2, M4 and M5 above.

2-6 DEPOT-LEVEL SERVICE

Depot-level service requires a thorough understanding of

radio circuitry and the availability of laboratory test equipment. Only skilled technicians should attempt such repairs.

Once a faulty module has been located through the field repair procedures, turn to Chapters 4-10 for detailed circuit and repair information.

2-6.1 TEST EQUIPMENT

Specific types of test equipment have been recommended for depot-level servicing of the PRC1077. See Table 2-7 for a list of the instruments and the relevant characteristics.

2-6.2 POWER MEASUREMENT

Unless sophisticated laboratory equipment is available, the usual method of PRC1077 power measurement is to use an in-line wattmeter and a 50-ohm load. Considering losses in the connectors and cables the accuracy of such an instrument at the 5-W level is approximately 20 %. At lower power levels, the measurement inaccuracies are even greater. These inaccuracies are of minor importance, because the smallest detectable power change on a received signal is about 2:1. If the power output reads 3.5 W or more in the HI power position and drops to 1/4 of that level at MED power and yet another 1/4 at LO, output should be considered satisfactory. Before attempting to measure power output, read procedure 8, "POWER OUTPUT TEST," in Section 2-4.4.

2-6.3 SPECTRUM ANALYZER

Although a spectrum analyzer is not essential for servicing the transceiver, it is both useful and recommended. With it, simultaneous examination of both frequency and amplitude characteristics can be made. This allows display of the various RF signals for spectral purity and spurious products. For example, the output from the phaselocked loop in the transceiver can be examined for lock, satisfactory phase-noise level and freedom from spurious outputs.

The spectrum analyzer must be connected, via an attenuator, to the transceiver output, to display harmonics and spurious outputs. When used in this manner, it is very important not to overload the spectrum analyzer input, or it will generate harmonics internally.

2-6.4 SIGNAL GENERATOR

The signal generator is used primarily as an instrument for testing the receiver. However, it can also be used as a substitute for internal oscillators in the transceiver, such as the synthesizer.

2-6.5 FREQUENCY COUNTER

Apart from frequency calibration, this instrument is a useful tool for servicing the synthesizer. By connecting the counter to different points in the circuitry, it is possible to check that correct divide ratios are occurring.

2-6.6 SEMICONDUCTOR SERVICING

General

There are two distinct classes of semiconductors used in

the transceiver: discrete devices, such as transistors and diodes, and monolithic integrated circuits (see Table 1-2). Considerable information can be found about the operation of the transistors and diodes by measuring the voltage on the various leads. With integrated circuits, there is no external access to much of the circuitry, and it is often necessary to use the "black box" or substitution approach to servicing.

Signal & Switching Diodes

All diodes may be checked with an ohmmeter. They should show a low forward resistance and a very high back resistance. Check the circuit before making any measurements, as the diode will frequently be shunted by other components—requiring one lead to be lifted before the measurement can be made.

Many of the diodes are used as switches or gates. If the diode is operating correctly, there will be a drop of ap-

proximately 0.7 V across the diode junction in the ON state.

Varactor Diodes

The varactor diode is designed to change capacitance across the reverse-biased junction as the voltage applied to it is changed. Varactors exhibit the same resistance characteristics as signal diodes and can be checked in the same way.

Bipolar Transistors

An out-of-circuit method of checking bipolar transistors is to consider the base-emitter and the base-collector junctions as two separate diodes. One lead of the ohmmeter is connected to the base and the other is first connected to the collector and then to the emitter. The ohmmeter leads are then reversed in polarity and the test repeated. This test should indicate high resistance with the leads in one polarization and low resistance in the other. Rarely will a transistor passing this test prove to be faulty in other ways.

**TABLE 2-6.
Module Function Chart.**

FUNCTION	I/O
<p>M1 Audio Module:</p> <ol style="list-style-type: none"> 1. Amplifies microphone input. 2. Controls modulation level. 3. Adds 150-Hz tone to modulation. 4. Adds wideband modulation with shorting pin to disable microphone. 5. Outputs speaker audio to J1, J2 and wideband audio to J3. 6. Controls squelch operation in receive. 7. Inhibits sidetone when no RF output. 8. Detects 150-Hz tone. 	<p>Input from front panel handset. Outputs modulator to M2 synthesizer.</p> <p>Data input from M3A.</p> <p>600-Hz tone input from M3B.</p> <p>Wideband and shorting pin inputs from front panel J3.</p> <p>Audio input from M5 receiver. Sidetone derived from microphone audio input.</p> <p>Busy signal input from M5 receiver. TONE, SQUELCH, TEST signals input from mode switch. Front panel S1.</p> <p>RF detect signal input from M7. T+ input from M3B.</p> <p>600-Hz input from M3B, provides RETX PTT (GND) when in RETX mode.</p>
<p>M2 Synthesizer:</p> <ol style="list-style-type: none"> 1. Generates TX exciter and RX L.O. frequencies. 2. Switches between TX and RX. 3. Generates loss-of-lock signal. 	<p>Data stream input from M3A determines synthesizer band and frequency.</p> <p>PTT input from front panel J1, J2.</p> <p>Loss-of-lock output to M3B and inhibits transmit.</p>

**TABLE 2-6.
Module Function Chart, Continued.**

FUNCTION	I/O
<p>M3 Processor Module:</p> <ol style="list-style-type: none"> 1. Controls modulation level. 2. Tunes receiver. 3. Selects transmitter band. 4. Sets synthesizer frequency. 5. Sets display. 6. Controls antenna tuner. 7. Controls frequency selection. 	<p>Outputs data to M1 audio.</p> <p>Outputs tune voltage and band select to M5 receiver.</p> <p>Outputs band select and latch signals to M4 transmitter.</p> <p>Outputs data to M2 synthesizer.</p> <p>Outputs data to M6 display.</p> <p>Outputs data to M7 antenna tuner.</p> <p>Inputs from front panel UP, DN PTT and channel-select switches.</p>
<p>M4 Transmitter:</p> <ol style="list-style-type: none"> 1. Amplifies RF signal. 2. Filters harmonics. 3. Selects power level. 	<p>RF input from M2 synthesizer. TX output to M7 antenna tuner.</p> <p>Band select from M3 module.</p> <p>Inputs from front-panel switch S3.</p>
<p>M5 Receiver:</p> <ol style="list-style-type: none"> 1. Receives RF signal. 2. Generates audio. 	<p>L.O. input from M2 synthesizer band select, tune voltage from M3.</p> <p>Audio output to M1 audio module. Outputs busy squelch control signal to M1 audio module.</p>
<p>M6 Display Module:</p> <ol style="list-style-type: none"> 1. Displays operating frequency. 2. Generates display back light. 	<p>Data input from M3 processor.</p> <p>Ground from mode switch.</p>
<p>M7 Antenna Tuner:</p> <ol style="list-style-type: none"> 1. Tunes antenna. 2. Detects RF presence in TX. 	<p>Network select data input from M3.</p> <p>Outputs RF detect logic signal to M1 audio module.</p>

A simple, in-circuit check of a transistor can be made with a VTVM. The potential across the base emitter junction should be about 0.7 V. A substantial difference indicates a fault in the transistor or possibly in the surrounding circuitry.

Integrated Circuits

Complex, internal IC circuitry makes it impractical to do any analytical fault finding in the device itself. The best approach to servicing them is to isolate the fault to a par-

ticular stage. Pin voltages should then be checked against typical values given in the charts. If there are any substantial variations, first check the surrounding circuit components. Finally, the IC may be checked by substitution.

2-6.7 COMPONENT REPLACEMENT

Circuit Boards

All transceiver printed circuit boards are heavy epoxy fiberglass with 2-oz. tinned copper foil, which meets ap-

**TABLE 2-7.
Test Equipment.**

ESSENTIAL

Synthesized Signal Generator:	Frequency range = 10.7 MHz, 30-88 MHz. Frequency calibration accuracy = 5 kHz (minimum). Output = 0.1 μ V to 1 V (with accurate attenuator). Modulation = FM adjustable 0-15 kHz.
Deviation Meter:	Frequency range = 30-88 MHz. Deviation = 0-15 kHz.
Sinadder:	Measures SINAD at 1000 Hz.
Electronic Multimeter:	General purpose. Input Impedance 11 megohms (minimum).
Digital Voltmeter:	General purpose. Accuracy 1 % (10-V range).
Frequency Counter:	Frequency range = 1-100 MHz. Accuracy = 5 ppm (minimum).
Wattmeter:	Impedance = 50 ohms. Power = 10 W (full scale). Frequency = 30-88 MHz. (Thru-line, 10-W element, and RF load/attenuator.)
Power Supply:	13.8 Vdc 2 A regulated.

OPTIONAL

Oscilloscope:	General purpose. Frequency response 100 MHz.
Audio Signal Generator:	100 Hz - 20 kHz.
RF Millivoltmeter:	Frequency range = 0.5-100 MHz. Ranges 10 mV to 3 V.
Spectrum Analyzer*:	Frequency Range = 10-300 MHz. Resolution = 5 kHz.

* Should only be used by qualified test engineer.

plicable military specifications. Faults in the board are not likely to occur unless careless procedures are used when replacing components. If correct procedures are followed, components can be replaced many times without damage to the board. All integrated circuits are installed in sockets, which makes replacement very simple.

Begin with the correct tools. The soldering iron must have a small, instrument-type tip no larger than the circuit board pads. However, do not use a tiny, low-temperature, instrument-type iron. It must have sufficient heat to melt the solder quickly, otherwise component and/or board damage can occur.

Use the iron to melt the solder at the connection. While still molten, remove it with a desoldering tool. (These come in many forms, but even a simple type, consisting of

a suction pump with a teflon tip will be satisfactory.) After all solder has been removed, the component can be taken out by giving it a gentle tug. To reduce the risk of board damage, do not exert any stress on the foil while removing the component, especially when the connection is hot. The copper foil adhesive forms an extremely strong bond to the board when cold, but can be removed fairly easily at soldering temperature.

Before installing the new component, it is important to clear the holes of any remaining solder. This can be achieved by again applying heat and using the desoldering tool. A frequent cause of foil damage is to push the component through the hole and melt the solder at the same time. If the lead catches, it will frequently lift the foil from the board.



CHAPTER 3

GENERAL THEORY OF OPERATION

3-1 INTRODUCTION

This is a general description of the transceiver. Chapters 4-10 give a detailed circuit description of each module as well as technical specifications and servicing data.

3-2 SYNTHESIZER

The synthesizer is the heart of the transceiver. In the transmit mode, the synthesizer output is on the transmit frequency. In the receive mode, the synthesizer moves 10.7 MHz to enable the oscillator frequency to down convert to the 10.7-MHz intermediate frequency. The synthesizer covers the frequency range 30-88 MHz in 25-kHz increments.

The receiver oscillator injection is on the high side from 30-51.975 MHz and on the low side from 52-88 MHz. The synthesizer uses a single phase-locked loop with the VCO operating at the output frequency. The synthesizer makes use of a modern LSI synthesizer integrated circuit and a dual-modulus (32/33) prescaler. This gives a very simple design using only two integrated circuits. The use of a signal loop design running directly at the operating frequency gives great freedom from spurious responses.

A single 6.4-MHz crystal provides the reference frequency for the synthesizer. The oscillator is temperature compensated and provides excellent frequency stability over temperature extremes. The entire frequency calibration of the transceiver is a single adjustment of the reference oscillator.

Four separate VCO's are used in the synthesizer. This ensures good spectral purity, an important consideration when operating in the retransmit or repeater modes.

The synthesizer is a serial-entry type directly controlled by the microprocessor. This means that only three operating lines, between the microprocessor and the synthesizer, control the selection of any frequency in the operating range.

3-3 MICROPROCESSOR

The microprocessor provides complete control of the entire transceiver. It provides frequency control of the synthesizer, tunes the antenna tuner and receiver, selects the correct filters, adjusts the transmitter deviation and operates the liquid-crystal frequency display on the front panel.

An internal battery, with a nominal operating life of 10 years, sustains the microprocessor memory. This means that the frequency information entered in each of the 10 memory channels is retained in permanent memory until changed by the operator.

The microprocessor uses serial output to control the transceiver. This results in great economy of wiring, as all operations are controlled by the common data lines. In the transceiver all mechanical tuning has been eliminated by using the microprocessor control.

3-4 RECEIVER

The receiver follows conventional design techniques. It uses a tuned RF amplifier and mixer stage and down converts to the 10.7-MHz intermediate frequency. An eight-pole, 10.7-MHz crystal filter is followed by a single-stage IF amplifier and then an MC3357 integrated circuit. This low-power device (6 V at 3 mA) includes oscillator and mixer for down conversion to 455 kHz, a limiting amplifier, quadrature discriminator, active filter, and noise-operated squelch. A single-stage operational amplifier provides fixed wideband audio output for high-speed data operation. A 300-Hz active, high-pass audio filter suppresses the 150-Hz tone squelch and an integrated-circuit audio amplifier provides headphone or loudspeaker output.

The operating range is divided into four bands, and four separate RF stages are used for maximum efficiency and minimum noise level. The RF stage and tuned circuits are selected by pin diodes controlled from the microprocessor. The circuits are tuned by varactors. The tuning voltage is derived from a digital-to-analog converter under the control of the microprocessor.

The transceiver uses both noise-operated and 150-Hz tone-controlled squelch systems. The tone-detect circuit uses a highly selective commutating filter which automatically adjusts to the internal transmit tone standard.

3-5 TRANSMITTER

The transmitter in the transceiver is very simple. The synthesizer output is on the transmit frequency and no multiplication or conversion is required. Three broadband amplifiers are used to amplify the output level to 5 W. Four separate low-pass filters are selected to provide good harmonic suppression. The good spectral purity from the synthesizer means no other filtering or tuning is required.

The transmitter audio stages comprise a high-gain microphone amplifier and clipper followed by a 3-kHz audio filter. The processed output goes through a summing amplifier where the 150-Hz tone is injected. The wideband audio input is also summed at this input. A further amplifier sets the modulation gain level.

The transmitter audio is applied directly to the VCO control voltage. This results in low-distortion direct-frequency modulation of the output. As the frequency deviation will

change with frequency, the modulation gain is changed automatically by the microprocessor to ensure constant deviation over the entire frequency range.

3-6 ANTENNA TUNER

The transceiver has a 50-ohm output for coaxial-fed antennas and operates with 3-ft and 10-ft whip antennas in the manpack configuration. Five inductors may be selected in a binary progression to vary the inductance from 0-2 microhenrys in 0.06-microhenry increments. Shunt and

series capacitors may also be selected. The capacitors and inductors are selected using latching relays that only draw current in the switching mode. The tuning program is controlled by the microprocessor. A micro switch at the antenna base determines which antenna is in use.

3-7 SIGNAL FLOW CHARTS







Table 3-1 indicates the signal levels at various stages of the receive signal path, while Table 3-2 does the same for the transmit signal path.

**TABLE 3-1.
Receive Signal Flow.**

INITIAL CONDITIONS

Frequency: 30.000 kHz.
 Mode: RX test.
 Volume: Fully CW.

Initially inject 0.35 μ V at 30,000 kHz, 6 kHz deviation, into 50- Ω antenna jack.

<u>LOCATION</u>	<u>SIGNAL</u>	<u>COMMENTS</u>
1. M5 Receiver		
	\rightarrow $\leftarrow \approx 1 \mu$ s	
M5U1, Pin 16	 25 mV	IF Signal
	\rightarrow $\leftarrow \approx 1$ ms	
M5U1, Pin 9	 3.5 V	Audio Signal
	\rightarrow $\leftarrow \approx 0.025 \mu$ s	
M5Q5, G2	 2.2 V	Receive Local Oscillator
	\rightarrow $\leftarrow \approx 0.1 \mu$ s	
M5U1, Pin 1	 0.3 V 10.245 MHz	Y1 Oscillator
	\rightarrow $\leftarrow \approx 1$ ms	
M5J1, Pin 5	 5.0 V	Audio Signal
2. M1 Audio Module		
M1J1, Pin 7	Same as M5J1	
M1U3, Pin 7	Same as M5J1	
	\rightarrow $\leftarrow \approx 1$ ms	
M1U9, Pin 1	 0.6 V	Audio Signal
	\rightarrow $\leftarrow \approx 1$ ms	
M1U6, Pin 5	 13 V	Audio Signal
J1, Pin B	Same as M1U6, Pin 5	

**TABLE 3-2.
Transmit Signal Flow.**

INITIAL CONDITIONS

Mode: RX test.
 Frequency: 30,000 kHz.
 Input Level/Frequency: 150 mV/1 kHz.

NOTE: Key Transmitter for All Checks

<u>LOCATION</u>	<u>SIGNAL</u>	<u>COMMENTS</u>
1. M1 Audio Module		
M1U1, Pin 7	2 V	Audio Signal
M1U1, Pin 1	0.8 V	Audio Signal
(Switch to "tone" position on mode switch.)		
M1U2, Pin 1	≈ 0.2 V	150-Hz Tone Signal
M1U2, Pin 7	0.5 V	150-Hz Tone Signal
M1J2, Pin 9	0.2 V	150-Hz Tone Signal
2. M2 IF Module		
M2Q16, C	0.5 V	30,000 kHz RF Signal (modulated)
M2, TX Out	2 V	30,000 kHz RF Signal (modulated)
3. M3 P.A. Module		
M4, Q1 C	3 V	RF Signal
M4, Q2 C	12 V	RF Signal
M4, Q3-Q4 C	35 V	RF Signal Push-Pull Configuration
M4, R14	85 V	RF Signal Combined
M4, TX RF	70 V	RF Signal

CHAPTER 4

AUDIO MODULE, M1 - THEORY OF OPERATION

4-0 INTRODUCTION

The M1 module contains the receive and transmit audio-processing circuitry for the PRC1077. It is all contained on printed circuit board 738137, which is mounted on a metal plate attached to the bottom right-hand side of the main chassis (Figure 1-4). Instructions for accessing and removing the M1 module are given in section 2-5.2.

4-1 MODULE INTERCONNECTIONS

The M1 module has the following interconnects with the transceiver:

Connector M1J1 (located at front-panel side of module—see Figure 1-4):

- Pin 1 Shield ground for mic audio.
- Pin 2 Mic Audio. Connected to front-panel audio connectors J1 and J2, pin D, and front-panel power connector J3, pin D.
- Pin 3 Shorting pin for allowing processing of wideband transmit audio inputs. Connected to pin L on front-panel power connector J3; this pin must be grounded to use wideband audio input transmission.
- Pin 4 Wideband Audio Input. Connected to pin R on front-panel power connector J3; 0 dBm at 600 ohms.
- Pin 5 Top side of front-panel volume control, R1.
- Pin 6 Wideband audio output. Connected to pin P of front-panel connector J3. 0 dBm at 600 ohms.
- Pin 7 Standard receive audio input. Connected to pin J1-5 of the receiver module (M5).
- Pin 8 +12 Vdc, switched.
- Pin 9 Standard receive audio output. Connected to pin B of front-panel audio connectors J1 and J2, and pin B of front-panel power connector J3; 0.5 W into 16 ohms or 0.05 W into 150 ohms.
- Pin 10 Ground side of front-panel volume control, R1.
- Pin 11 Wiper for front-panel volume control, R1.
- Pin 12 T+; regulated +12 Vdc only in transmit mode.

Connector M1J2 (located at rear of module—see Figure 1-4).

- Pin 1 Retransmit switch; connected to “RETX” position on front-panel mode switch S1. Line is grounded when RETX module is selected and open otherwise.
- Pin 2 Retransmit PTT. Connected to pin E on front-panel audio connectors J1 and J2, and pin K of front-panel audio connector J3.
- Pin 3 Test. Connected to “RX TEST” position of front-panel mode switch S1. Line is grounded when RX test mode is selected and open otherwise.
- Pin 4 Tone squelch. Connected to “TONE” position of front-panel mode switch S1. Line is grounded when 150-Hz tone squelch mode is selected and open otherwise.
- Pin 5 Noise squelch. Connected to pin J1-3 of receiver module (M5). Line is grounded when noise squelch mode is selected.
- Pin 6 RF Det. Connected to pin J1-1 of antenna-tuner module (M7). Line is grounded when transmit RF power is detected in the M7 (at the 50-ohm antenna port), and +12 Vdc otherwise.
- Pin 7 600 Hz. Connected to pin J6-3 of the processor module (M3). A 5-V peak, 600-Hz signal generated in the M3B module.
- Pin 8 Ground.
- Pin 9 Modulated transmit audio. Connected to pin J1-6 of the synthesizer module (M2).
- Pin 10 +5 Vdc, regulated.
- Pin 11 Audio clock. Connected to pin J2-3 of the processor (M3) module. A 5-V peak, square wave generated in the M3A module.
- Pin 12 Data. Connected to pin J3-5 of the processor (M3) module.

4-2 CIRCUIT DESCRIPTION

4-2.1 TRANSMIT FUNCTION

Microphone Amplifier & Limiter

The microphone amplifier and limiter U1B is one section of a dual, low-power, low-offset, voltage comparator used as a high-gain microphone amplifier. The stage gain is set by R3 so that the stage limits at input levels over 1 mV.

The low offset ensures symmetrical clipping of the output waveform. Limiting is used in frequency-modulated transmitters to increase the average modulation level without exceeding the specified deviation limit.

Low-Pass Filter

The other section of the dual operational amplifier U3A is used as an active low-pass filter. The frequency cutoff is 3000 Hz with an attenuation of 12 dB/octave. This filter has the important function to limit the transmitter frequency response and to attenuate the harmonic spectrum generated by the limiting in the preceding stage U1B.

Summing Amplifier

The summing amplifier U2A is one section of a dual low-power, JFET-input, operational amplifier. The gain of this stage is set at unity by R32. The output from the microphone and the 150-Hz tone are summed in the amplifier to provide the composite audio and tone code modulation for the transmitter. The wideband audio port is also summed in the amplifier. This bypasses the processing and filtering at the microphone input and permits the transmission of high-speed data. When the wideband input is in use the shorting pin input J1-3 is grounded, which causes the output of operational amplifier, U1A pin 1 to go low. This causes Q8 to turn off, which removes both the 150-Hz tone and microphone audio.

Modulation Gain Control

The modulation gain control is comprised of U2B, U4 and U5. A section of the dual-operational amplifier U2B is used as the gain-controlled stage. The gain is set by the variable feedback network comprising R34 and the selectable resistors R38-R42.

The method used to modulate the transmitter is to apply the audio directly to the phase-locked loop in the synthesizer. This gives very-low-distortion linear-frequency modulation as a constant percentage of the frequency. This means that the frequency deviation will decrease as the frequency is increased. To ensure the deviation is constant on every channel in the operating range, a modulation level table is stored in the microprocessor memory. Every time the channel frequency is changed, the microprocessor looks up the table to set the modulation gain correctly.

The modulation gain setting is sent out from the microprocessor in a serial data stream and is applied to the shift register U5. The serial data fills the register and provides parallel outputs which drive U4; a hex, open drain, N-channel buffer. The six outputs are connected to the binary-stepped resistors R37-R42, giving a resistance range of 50 k Ω to 3.3 M Ω in 64 steps. The feedback network for U2B has been chosen so that the amplifier gain is controlled over a 3:1 range. The microprocessor changes the gain at 73 points in the tuning range, which ensures accurate control of the transmitter frequency deviation. The overall deviation level is set by the gain-control trimmer R35.

Tone Modulation

The standard configuration of the transceiver is to transmit the 150-Hz tone modulation in all front-panel switch positions. This ensures full operational compatibility with the PRC-77 family of military radios and allows communications despite operator error. To enable the transmit 150-Hz tone only in the front-panel tone-switch position, the "TX Tone Select" jumper (in the vicinity of U8) should be removed. The 150-Hz tone modulation is compatible with other military equipment using tone squelch. The tone is initially generated at 614.4-kHz by an oscillator using a stable ceramic resonator. The 614.4-kHz tone is divided by 1024 and the 600-Hz output from the processor module is applied to the audio module. The 600-Hz tone is then divided by 4 in the divider U8, and the 150-Hz square wave output is applied to the active low-pass filter via the Darlington transistor Q7. This filter has a cutoff frequency of 150 Hz. The harmonics are attenuated and the sinewave output is used to provide tone modulation of the transmitter.

4-2.2 RECEIVE FUNCTION

Audio Amplifiers

The audio input from the receiver module is applied to U3B, one section of a dual low-power, JFET-input operational amplifier, with the gain set at unity. This stage provides buffering for the wideband audio output which is available for high-speed data reception. The audio output then goes through the front-panel, audio gain control to U9A, another low-power operational amplifier connected as a high-pass filter with a 300-Hz cutoff. This filter removes low-frequency noise and suppresses the 150-Hz tone signal. The audio output stage U6 is an integrated-circuit power amplifier with the stage gain set at 20. The amplifier will deliver 10 mW into 900 ohms for operation with the handset and 500 mW into 16 ohms for loudspeaker operation. The stage has an unswitched quiescent current of approximately 4 mA, which helps give low current drain in the unswitched condition. There are two inputs, inverting and noninverting, to U6. The inverting input is used to apply the transmit sidetone which is derived from the output of the summing amplifier U2A.

Tone Decoder

The tone decoder comprises U7, U8 and U9B. The 600-Hz tone from the microprocessor module is applied to the counter U8. The divide by 2 and 4 outputs are used to apply 300 Hz and 150 Hz to U7, a multiplexer, which is connected as a 150-Hz commutating filter. This type of filter requires no adjustment and provides excellent selectivity at exactly 150 Hz. U9B is an operational amplifier with the positive (+) input biased so that the output of the device is low. The audio from the receiver is applied to the negative (-) input which is also through the 100-k Ω resistor R12. The negative (-) input is also connected to the commutating filter. This type of filter has a low impedance output except at the filter frequency and, in combination with R17, provides high attenuation at all frequencies except 150 Hz. When the 150-Hz tone is present in the

receiver audio, the output of U9B will swing positive, and the filtered output is applied to the logic circuitry to control the tone squelch and retransmit functions.

4-2.3 CONTROL CIRCUITRY

Voltage Regulation

There are three supply voltages on the audio board. The unregulated 12 V is supplied directly from the battery. The regulated 5 V is supplied from the regulator in the processor module. The regulated 8 V is supplied by a three terminal regulator U11 whose output voltage is set by resistors R68 and R69.

Gates & Switching Functions

It is desirable to squelch the receiver when the microprocessor is operating to prevent switching noise in the receiver output. Q6 is connected to the data line and is biased on whenever data is present. This pulls one of the logic gates low and mutes the receiver audio in all conditions except the test position on the function switch.

The transistor switch Q2 is switched on by the T+ voltage and shorts the output from the receiver to ground in the transmit mode. The P channel FET Q3 shorts the output of the transmitter audio amplifiers in the receive mode to prevent unwanted sidetone in the receiver and modulation of the synthesizer. It is necessary to leave the transmitter audio amplifiers on in the receive mode to prevent receive-transmit switching delays.

The transistor switch Q1 in the 12-V supply is the main squelch gate. It is necessary to use supply switching to reduce the battery drain when the receiver is squelched.

The transistor switch Q5 is used to control the retransmit PTT line to activate the transmitter in the second transceiver in the retransmit system.

Logic Circuitry

The quad NAND gate U10 and Q4 are used to control the various switching and mode-control functions in the audio module. These control functions are as follows.

The receive audio is squelched when the transistor switch Q1 is open. The bias resistors R20-R22 are connected to

the outputs of the NAND gates U10B, C and D. R23 is connected to the test position on the mode switch. Q1 is closed and the receiver audio operates when any one of the four bias resistors R20-R23 are grounded. The receiver squelch is opened under any of these conditions:

Inputs to U10D	High
Inputs to U10C	High
Inputs to U10B	High
Test line grounded (function switch in test position)	

U10B - Opens audio when T+ and RF detect are present. Note U10A acts as an inverter for the RF detect signal which is normally low. This logic turns off the sidetone to indicate a transmit failure.

U10 C - Opens audio when noise squelch is open. (This grounds one input.) This logic is also inhibited when the mode switch is in the retransmit position. One input is grounded through D2.

U10D - Opens audio when noise squelch is open and the output from U9B indicates the presence of the 150-Hz tone.

Q4/Q5 - Switches the retransmit PTT line when 150-Hz tone output from U9B is present, and the emitter of Q6 is grounded through D1 by the mode switch in the retransmit position.

4-3 VOLTAGE CHARTS

Table 4-1 shows dc voltage levels at the pins of the M1 module transistors and IC's.

4-4 ALIGNMENT

4-4.1 DEVIATION LEVEL

R35 is used to set the deviation level. One quick way of doing this is to connect the radio to a 50-ohm dummy load, place the mode switch in the SQUELCH position, set a channel frequency (Man. Position) of 30.000 MHz, and inject a 150-mV, 1-kHz sine wave from an audio signal generator into the mic input. Then key the PTT line. Monitor the transmitted signal with a deviation meter and adjust R35 for 10-kHz deviation.

**TABLE 4-1.
M1 Dc Voltage Charts.**

INITIAL CONDITIONS								NOTE:			
Frequency:		30,000 kHz.						Q4 and Q5 voltages measured in valid retransmit configuration.			
Power:		Hi power.									
Mode:		RX test.									
Volume:		Mid range.									
Power Supplied:		13.8 Vdc.									

<u>LOCATION</u>				<u>VOLTAGE</u>				<u>LOCATION</u>				<u>VOLTAGE</u>			
<u>M1J1</u>	PIN	RX	TX	<u>M1J2</u>	PIN	RX	TX	<u>M1J2</u>	PIN	RX	TX	<u>M1J2</u>	PIN	RX	TX
	1	—	—		1	12.13	12.09		1	12.13	12.09		1	12.13	12.09
	2	—	—		2	0.0	0.0		2	0.0	0.0		2	0.0	0.0
	3	7.81	7.81		3	—	—		3	—	—		3	—	—
	4	—	—		4	12.44	12.35		4	12.44	12.35		4	12.44	12.35
	5	1.50	1.50		5	13.52	0.0		5	13.52	0.0		5	13.52	0.0
	6	0.002	0.035		6	13.50	0.0		6	13.50	0.0		6	13.50	0.0
	7	3.66	3.84		7	2.47	2.47		7	2.47	2.47		7	2.47	2.47
	8	13.80	13.80		8	—	—		8	—	—		8	—	—
	9	—	0.039		9	2.60	2.49		9	2.60	2.49		9	2.60	2.49
	10	—	—		10	5.00	5.00		10	5.00	5.00		10	5.00	5.00
	11	—	—		11	—	—		11	—	—		11	—	—
	12	—	12.52		12	—	—		12	—	—		12	—	—

<u>U1</u>	PIN	RX	TX	<u>U2</u>	PIN	RX	TX	<u>U3</u>	PIN	RX	TX
	1	7.74	7.74		1	3.52	3.52		1	3.54	3.54
	2	0.715	0.715		2	3.52	3.52		2	3.52	3.52
	3	7.81	7.81		3	3.48	3.48		3	3.50	3.50
	4	—	—		4	—	—		4	—	—
	5	3.48	3.48		5	0.20	3.52		5	4.90	4.90
	6	3.52	3.53		6	6.80	3.52		6	4.90	4.90
	7	3.49	3.49		7	6.90	3.52		7	4.90	4.90
	8	7.82	7.82		8	7.82	7.82		8	13.80	13.80

<u>Q1</u>	RX	TX	<u>Q2</u>	RX	TX	<u>Q3</u>	RX	TX	<u>Q4</u>	RX	TX	<u>Q5</u>	RX	TX	<u>Q6</u>	RX	TX
C	13.0	13.0	C	—	—	D	0.025	3.52	C	13.6	13.4	C	0.660	0.053	C	—	—
B	12.3	12.38	B	0.018	0.749	G	0.0	12.57	B	12.17	0.0	B	1.36	0.0	B	—	—
E	13.6	13.6	E	—	—	S	—	—	E	11.54	0.0	E	0.669	12.48	E	—	—
<u>Q7</u>	RX	TX	<u>Q8</u>	RX	TX												
C	13.6	13.6	D	7.63	7.63												
B	4.4	4.4	G	7.63	7.63												
E	3.44	3.49	S	7.16	7.16												

**TABLE 4-1.
M1 Dc Voltage Charts, Continued.**

	PIN	RX	TX		PIN	RX	TX		PIN	RX	TX		PIN	RX	TX
<u>U4</u>	1	0.0	0.0	U5	1	4.93	4.93	U7	1	2.5	2.5	U8	1	0.0	0.0
	2	0.0	0.0		2	—	—		2	2.5	2.5		2	2.5	2.5
	3	0.8	0.8		3	—	—		3	2.5	2.5		3	2.5	2.5
	4	4.9	4.9		4	4.93	4.93		4	2.5	2.5		4	0.0	0.0
	5	0.0	0.0		5	4.93	4.93		5	2.5	2.5		5	0.0	0.0
	6	0.0	0.0		6	—	—		6	0.0	0.0		6	2.5	2.5
	7	—	—		7	4.93	4.93		7	0.0	0.0		7	4.62	4.62
	8	4.92	4.92		8	—	—		8	0.0	0.0		8	0.0	0.0
	9	0.758	0.758		9	4.93	4.93		9	2.5	2.5		9	4.93	4.93
	10	4.92	4.92		10	4.93	4.93		10	2.5	2.5		10	4.93	4.93
	11	0.714	0.714		11	4.93	4.93		11	0.0	0.0		11	2.5	2.5
	12	4.92	4.92		12	4.93	4.93		12	0.0	0.0		12	0.0	0.0
	13	0.626	0.626		13	4.93	4.93		13	0.011	0.011		13	0.0	0.0
	14	4.93	4.93		14	0.0	0.0		14	0.0	0.0		14	2.5	2.5
					15	4.93	4.93		15	0.0	0.0		15	2.5	2.5
					16	4.93	4.93		16	4.93	4.93		16	4.93	4.93
<u>U6</u>	PIN	RX	TX	<u>U9</u>	PIN	RX	TX	U10	PIN	RX	TX				
	1	1.45	1.37		1	4.93	4.93		1	0.0	0.0				
	2	0.020	0.019		2	4.93	4.93		2	12.4	12.4				
	3	0.018	0.004		3	4.9	4.9		3	13.76	13.65				
	4	0.0	0.0		4	0.0	0.0		4	13.76	0.413				
	5	6.6	6.3		5	2.4	2.4		5	0.0	13.7				
	6	13.0	13.0		6	2.5	2.5		6	0.0	12.56				
	7	6.6	6.6		7	0.113	0.114		7	0.0	0.0				
	8	1.3	1.3		8	13.6	13.6		8	13.48	0.0				
									9	13.48	0.0				
<u>U11</u>	PIN	RX	TX						10	0.0	13.7				
	1	12.31	12.22						11	13.76	13.65				
	2	7.82	7.82						12	0.0	0.0				
	3	13.8	13.8						13	0.0	0.0				
									14	13.8	13.8				

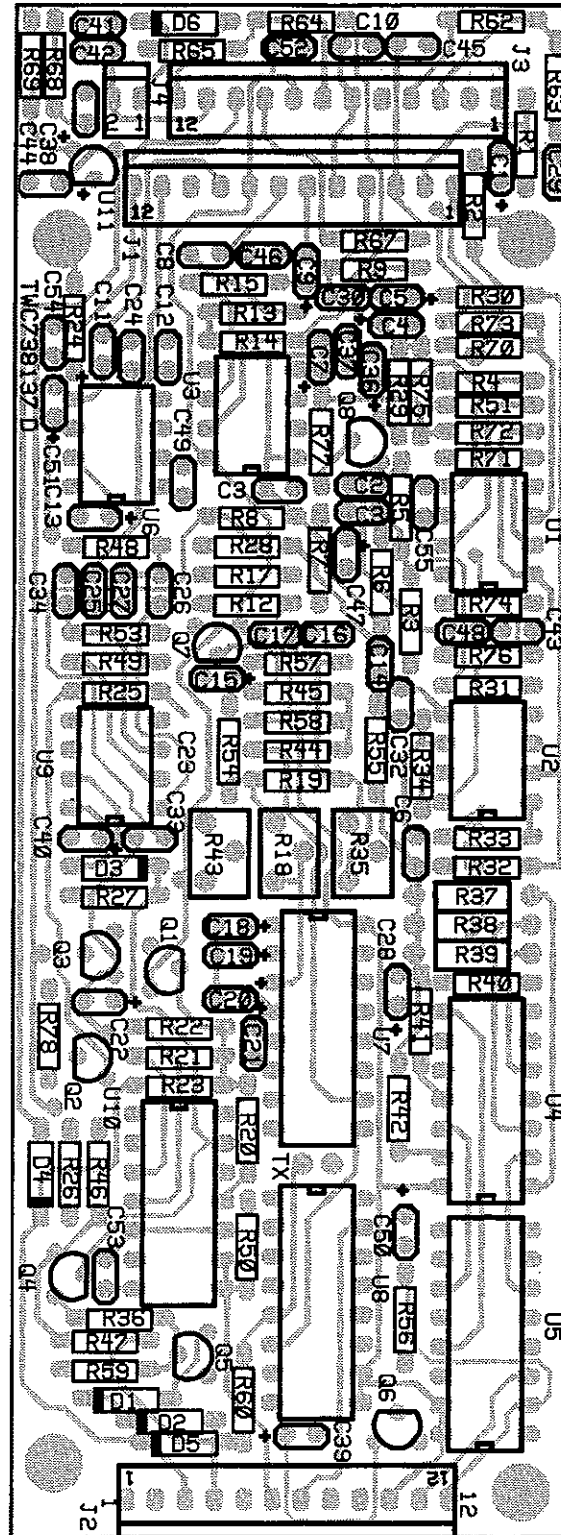

FIGURE 4-1.
Component Locations, Audio Module, M1.

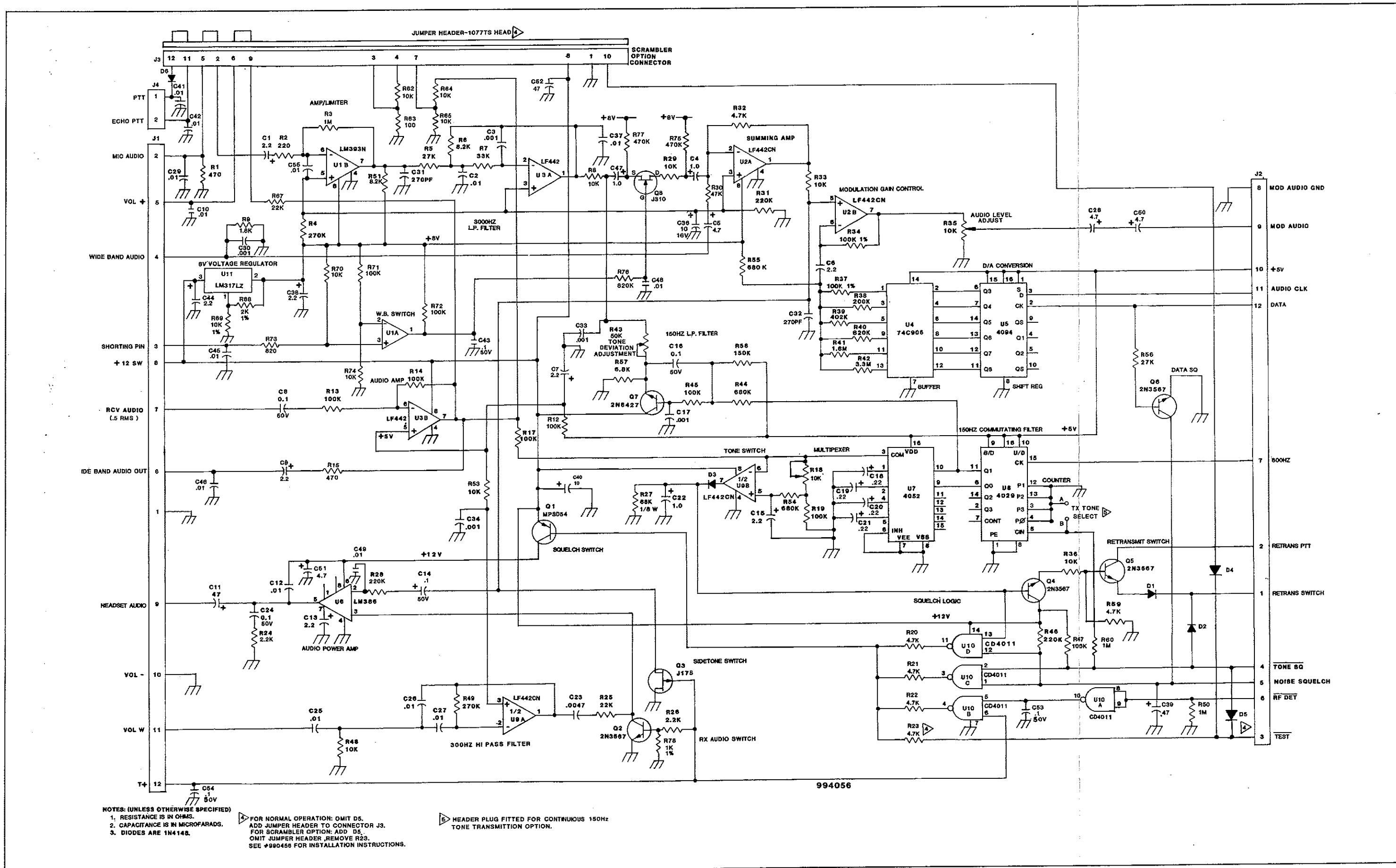

FIGURE 4-2. Schematic Diagram, Audio Module, M1.

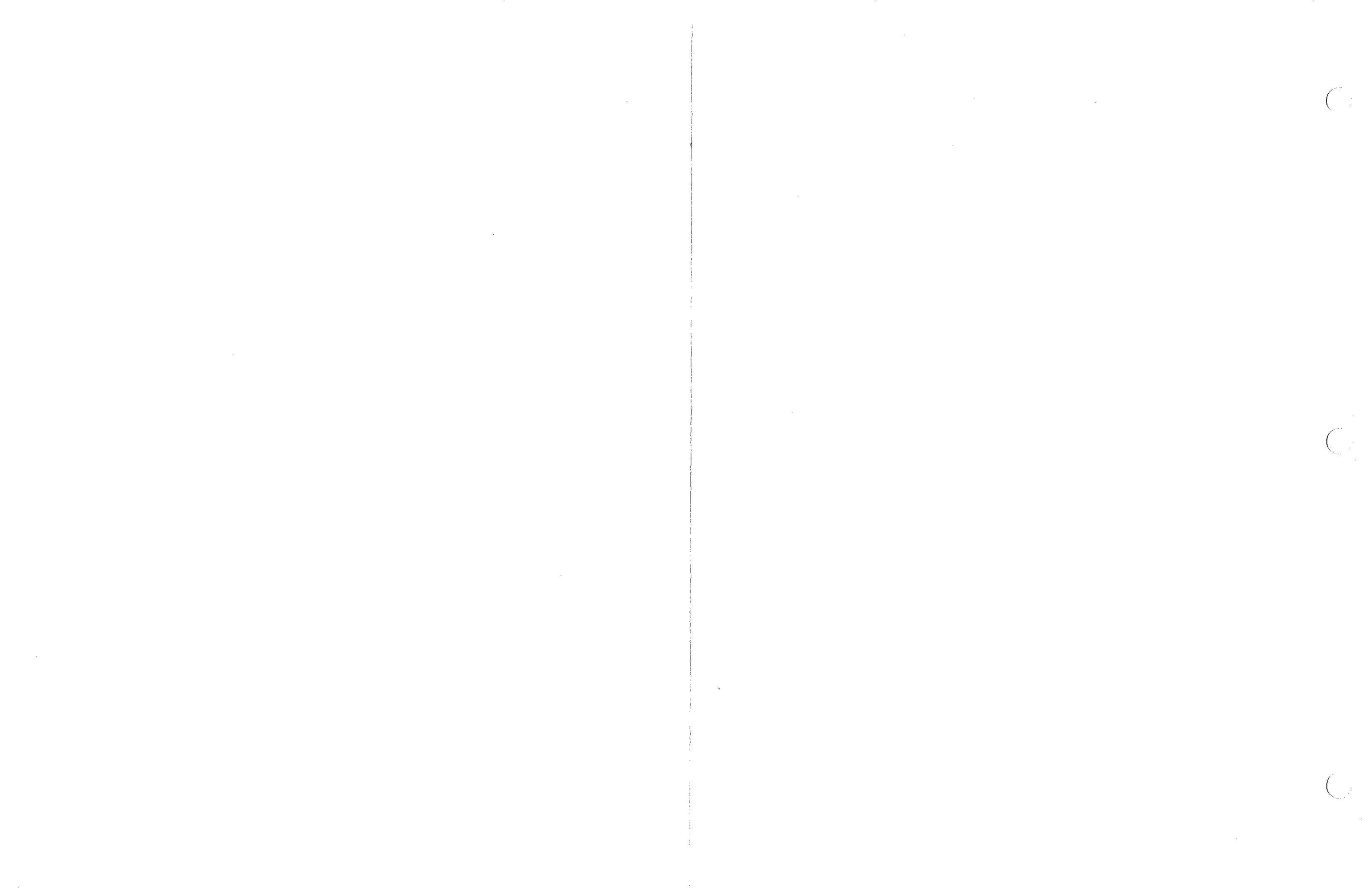

TABLE 4-2.
Parts List, Audio Module, M1.

C1	241020	Capacitor, Tantalum 2.2 μ F
C2	214103	Capacitor, Monolithic 50 V 0.01 μ F
C3	210102	Capacitor, Disc 0.001 μ F
C4	241010	Capacitor, Tantalum 1 μ F
C5	241040	Capacitor, Tantalum 16 V 4.7 μ F
C6	230020A	Capacitor, Electrolytic 50 V 2.2 μ F
C7	241020	Capacitor, Tantalum 2.2 μ F
C8	275104	Capacitor, Monolithic 50 V 0.1 μ F
C9	241020	Capacitor, Tantalum 2.2 μ F
C10	214103	Capacitor, Monolithic 50 V 0.01 μ F
C11	241476	Capacitor, Tantalum 16 V 47 μ F
C12	214103	Capacitor, Monolithic 50 V 0.01 μ F
C13	241020	Capacitor, Tantalum 2.2 μ F
C14	275104	Capacitor, Monolithic 50 V 0.1 μ F
C15	241020	Capacitor, Tantalum 2.2 μ F
C16	275104	Capacitor, Monolithic 50 V 0.1 μ F
C17	210102	Capacitor, Disc 0.001 μ F
C18-C21	241002	Capacitor, Tantalum 16 V 0.22 μ F
C22	241010	Capacitor, Tantalum 1.0 μ F
C23	274472	Capacitor, Monolithic 0.0047 μ F
C24	275104	Capacitor, Monolithic 50 V 0.1 μ F
C25-C27	214103	Capacitor, Monolithic 50 V 0.01 μ F
C28	241040	Capacitor, Tantalum 16 V 4.7 μ F
C29	214103	Capacitor, Monolithic 50 V 0.01 μ F
C30	210102	Capacitor, Disc 0.001 μ F
C31,C32	221271	Capacitor, Mica DM5 270 pF
C33,C34	210102	Capacitor, Disc 0.001 μ F
C35		Not Used.
C36	241100	Capacitor, Tantalum 10 μ F
C37	214103	Capacitor, Monolithic 50 V 0.01 μ F
C38	241020	Capacitor, Tantalum 2.2 μ F
C39	241047	Capacitor, Tantalum 0.47 μ F
C40	237100	Capacitor, Electrolytic 16 V 10 μ F
C41,C42	214103	Capacitor, Monolithic 50 V 0.01 μ F
C43	275104	Capacitor, Monolithic 50 V 0.1 μ F
C44	241020	Capacitor, Tantalum 2.2 μ F
C45,C46	214103	Capacitor, Monolithic 50 V 0.01 μ F
C47	241010	Capacitor, Tantalum 1 μ F
C48,C49	214103	Capacitor, Monolithic 50 V 0.01 μ F
C50,C51	241040	Capacitor, Tantalum 16 V 4.7 μ F
C52	241476	Capacitor, Tantalum 16 V 47 μ F
C53,C54	275104	Capacitor, Monolithic 50 V 0.1 μ F
C55	214103	Capacitor, Monolithic 50 V 0.01 μ F
D1-D4	320002	Diode, 1N4148
D5*	320002	Diode, 1N4148
D6	320002	Diode, 1N4148
Q1	310060	Transistor, Darlington MPSD54
Q2	310003	Transistor, NPN 2N3567
Q3	310072	Transistor, J175
Q4-Q6	310003	Transistor, NPN 2N3567
Q7	310064	Transistor, Darlington 2N6427
Q8	310033	Transistor, JFET NCH J310
R1	113471	Resistor, Film 1/8 W 5% 470 Ω

TABLE 4-2.
Parts List, Audio Module, M1, Continued.

R2	113221	Resistor, Film 1/8 W 5% 220 Ω
R3	113105	Resistor, Film 1/8 W 5% 1 M Ω
R4	113274	Resistor, Film 1/8 W 5% 270 k Ω
R5	113273	Resistor, Film 1/8 W 5% 27 k Ω
R6	113822	Resistor, Film 1/8 W 5% 8.2 k Ω
R7	113333	Resistor, Film 1/8 W 5% 33 k Ω
R8	113103	Resistor, Film 1/8 W 5% 10 k Ω
R9	113182	Resistor, Film 1/8 W 5% 1.8 k Ω
R10,R11		Not Used.
R12-R14	113104	Resistor, Film 1/8 W 5% 100 k Ω
R15	113471	Resistor, Film 1/8 W 5% 470 Ω
R16	113223	Resistor, Film 1/8 W 5% 22 k Ω
R17	113104	Resistor, Film 1/8 W 5% 100 k Ω
R18	170221	Resistor, Trimmer 10 k Ω
R19	113104	Resistor, Film 1/8 W 5% 100 k Ω
R20-R23	113472	Resistor, Film 1/8 W 5% 4.7 k Ω
R24	124020	Resistor, Film 1/4 W 5% 2.2 Ω
R25	113223	Resistor, Film 1/8 W 5% 22 k Ω
R26	113222	Resistor, Film 1/8 W 5% 2.2 k Ω
R27	113683	Resistor, Film 1/8 W 5% 68 k Ω
R28	113224	Resistor, Film 1/8 W 5% 220 k Ω
R29	113103	Resistor, Film 1/8 W 5% 10 k Ω
R30	113473	Resistor, Film 1/8 W 5% 47 k Ω
R31	113224	Resistor, Film 1/8 W 5% 220 k Ω
R32	113472	Resistor, Film 1/8 W 5% 4.7 k Ω
R33	113103	Resistor, Film 1/8 W 5% 10 k Ω
R34	1111003	Resistor, Film 1/8 W 1% 100 k Ω
R35	170221	Resistor, Trimmer 10 k Ω
R36	113103	Resistor, Film 1/8 W 5% 10 k Ω
R37	1111003	Resistor, Film 1/8 W 1% 100 k Ω
R38	1112003	Resistor, Film 1/8 W 1% 200 k Ω
R39	1114023	Resistor, Film 1/8 W 1% 402 k Ω
R40	113824	Resistor, Film 1/8 W 5% 820 k Ω
R41	113165	Resistor, Film 1/8 W 5% 1.6 M Ω
R42	113335	Resistor, Film 1/8 W 5% 3.3 M Ω
R43	170232	Resistor, Variable 50 k Ω
R44	113684	Resistor, Film 1/8 W 5% 680 k Ω
R45	113104	Resistor, Film 1/8 W 5% 100 k Ω
R46	113224	Resistor, Film 1/8 W 5% 220 k Ω
R47	113104	Resistor, Film 1/8 W 5% 100 k Ω
R48	113103	Resistor, Film 1/8 W 5% 10 k Ω
R49	113274	Resistor, Film 1/8 W 5% 270 k Ω
R50	113105	Resistor, Film 1/8 W 5% 1 M Ω
R51	113822	Resistor, Film 1/8 W 5% 8.2 k Ω
R52		Not Used.
R53	113103	Resistor, Film 1/8 W 5% 10 k Ω
R54,R55	113684	Resistor, Film 1/8 W 5% 680 k Ω
R56	113273	Resistor, Film 1/8 W 5% 27 k Ω
R57	113682	Resistor, Film 1/8 W 5% 6.8 k Ω
R58	113154	Resistor, Film 1/8 W 5% 150 k Ω
R59	113472	Resistor, Film 1/8 W 5% 4.7 k Ω
R60	113105	Resistor, Film 1/8 W 5% 1 M Ω
R61		Not Used.
R62	113103	Resistor, Film 1/8 W 5% 10 k Ω
R63	113101	Resistor, Film 1/8 W 5% 100 Ω
R64,R65	113103	Resistor, Film 1/8 W 5% 10 k Ω

TABLE 4-2.
Parts List, Audio Module, M1, Continued.

R66		Not Used.
R67	113223	Resistor, Film 1/8 W 5% 22 k Ω
R68	1112001	Resistor, Film 1/8 W 1% 2 k Ω
R69	1111002	Resistor, Film 1/8 W 1% 10 k Ω
R70	113103	Resistor, Film 1/8 W 5% 10 k Ω
R71,R72	113104	Resistor, Film 1/8 W 5% 100 k Ω
R73	113821	Resistor, Film 1/8 W 5% 820 Ω
R74	113103	Resistor, Film 1/8 W 5% 10 k Ω
R75	113474	Resistor, Film 1/8 W 5% 470 k Ω
R76	113824	Resistor, Film 1/8 W 5% 820 k Ω
R77	113474	Resistor, Film 1/8 W 5% 470 k Ω
R78	113102	Resistor, Film 1/8 W 5% 1 k Ω
U1	330185	IC, LM393N
U2,U3	330162	IC, LF442CN
U4	330112	IC, MM74C906N
U5	330126	IC, CD4094BE/MC14094BCP
U6	330083	IC, LM386N-1
U7	330184	IC, CD4052BE
U8	330038	IC, CD4029
U9	330162	IC, LF442CN (Motorola)
U10	330035	IC, CD4011
U11	330343	IC, LM317LZ

* Part used for TACSEC option (see Chapter 12).

C

C

C

CHAPTER 5

SYNTHESIZER MODULE, M2 - THEORY OF OPERATION

5-0 INTRODUCTION

The block diagram of the synthesizer is shown in Figure 5-1. This is a completely self-contained single-loop digital synthesizer used to generate the frequency range 30-88 MHz, in 25-kHz steps. It has the following components.

1. Voltage-controlled oscillators (VCO).
2. Buffer amplifiers.
3. Low-pass filters.
4. Divide 32/33 prescaler.
5. Synthesizer MC145156.
6. Loop filter.
7. VCO switches and decoding.

NOTE

This synthesizer uses a phase-locked loop and dual-modulus prescaler to generate the output signal. It is important to at least have a basic understanding of these techniques in order to service the synthesizer properly. For this reason, a description of these techniques is included in Appendix A.

5-1 MODULE INTERCONNECTIONS

The M2 module has the following interconnections with the transceiver:

Connector M2J1 (located at the right side of the module on the top of the radio—see Figure 1-3):

- Pin 1. Spare.
- Pin 2. Clock line from M3J2-2; should be a 5-V square wave that will only be present during channel change or frequency change operations. Used to synchronize the programming input data from the processor module.
- Pin 3. Spare.
- Pin 4. Data line from M3J3-5; serial 19-bit data stream at a 5-V level used to program the synthesizer output frequencies.
- Pin 5. Enable line from M3J2-5; normally a 0-V signal, when the processor latches are loaded the enable line goes to +5 V to allow the data to program the synthesizer A and N counters.
- Pin 6. Mod audio line from M1J2-9; used to vary the synthesizer varactor tune voltage line to provide the frequency modulation for the transmitter. Depending upon transmitter frequency, this line can vary from 1 to 12.5 V.
- Pin 7. Loss-of-lock line from M3J6-6; normally 0 volts when the synthesizer is locked, this line will pulse between 0 and 5 Vdc when the synthesizer is unlocked to inhibit the transmitter.
- Pin 8. +12 Vdc, switched, input.

Pin 9. PTT line.

Pin 10. Ground.

5-2 CIRCUIT DESCRIPTION

5-2.1 VCOS

Four voltage-controlled oscillators are used to cover the frequency range. The correct oscillator is selected by the control information from the microprocessor. An error voltage produced by the phase detector sets the appropriate VCO to the correct frequency. The output of the VCO goes via the buffer amplifiers and filters to the synthesizer output, and also to the dual-modulus prescaler input. The output from the prescaler is divided to the reference frequency and applied to the phase detector to complete the loop.

Buffer Amplifiers

The buffer amplifiers increase the amplitude of the output signal and provide isolation from changing loads on the oscillator output. Another buffer is used to feed the prescaler and prevents spurious signals from the prescaler modulating the output.

Filters

Four three-section, low-pass, Chebishev filters are used to filter the VCO outputs. These filters prevent excessive harmonic output from the synthesizer.

Divide 32/33 Prescaler

This is a dual-modulus prescaler which can be programmed to divide by either 32 or 33. Its division ratio is controlled by the number programmed into the dual-modulus divide-by-A counter in the synthesizer chip. The prescaler divides down the frequency so it is in the range of the low-frequency programmable counters in the synthesizer chip. The dual-modulus prescaler is able to perform this function and still maintain the same frequency resolution.

5-2.2 SYNTHESIZER

The synthesizer chip consists of a selectable reference divider, phase detector, 10-bit programmable N counter, and 7-bit programmable A counter. The control to the counter is provided by a serial data stream from the microprocessor which is decoded by internal shift registers and stored in the internal latches.

The total divide ratio is expressed by the formula $N_t = 32N + A$, where $N_t = (\text{output frequency})/(\text{reference frequency})$. The output of the programmable divider is compared to the 25-kHz frequency in the phase detector. The reference frequency is generated by the synthesizer oscillator using an external 6.4-MHz crystal. An internal preset divide-by-

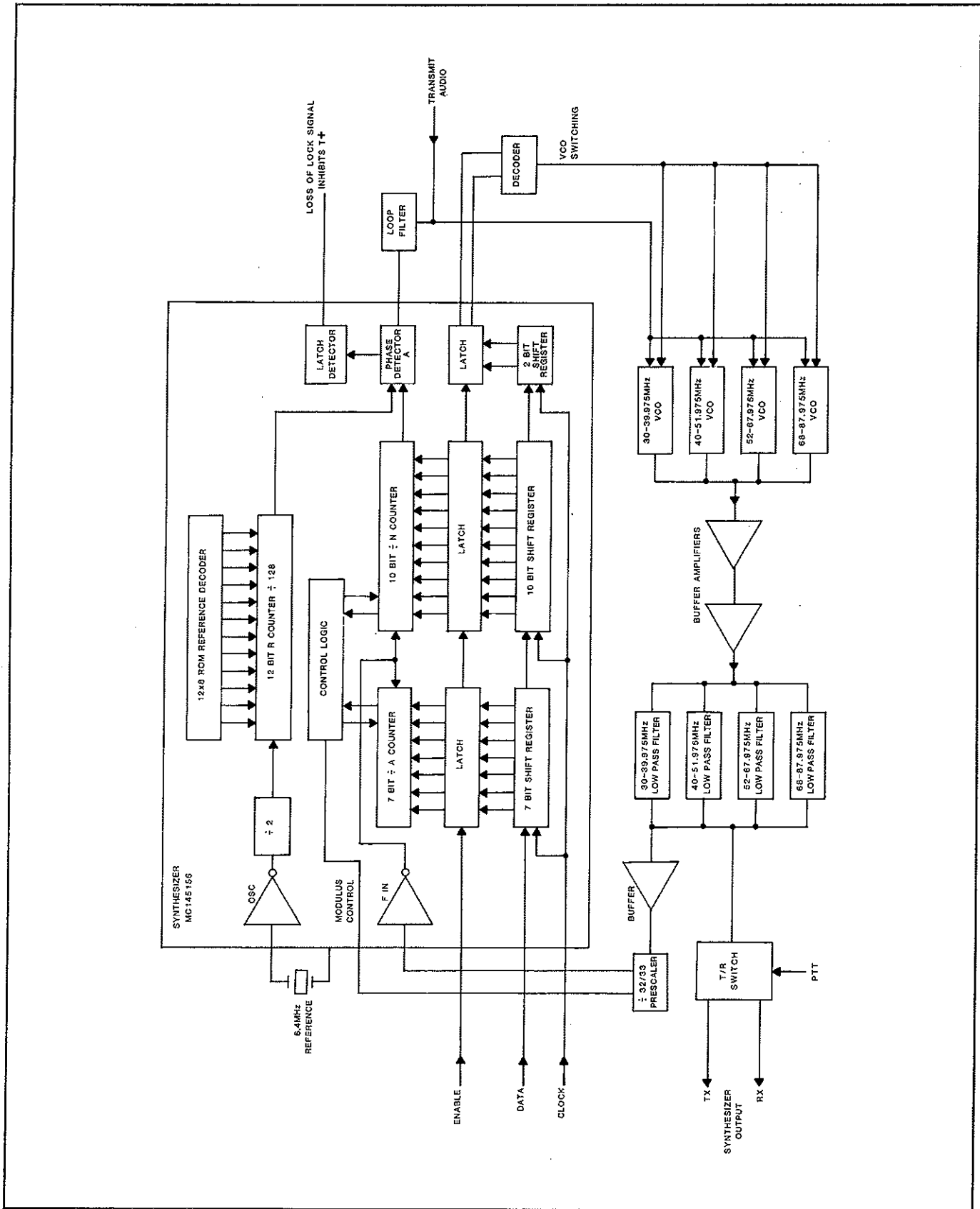

FIGURE 5-1.
Block Diagram.

256 counter produces the 25-kHz reference. The phase detector output is an error voltage used to correct the frequency of the VCO and locks it to the result of the reference frequency multiplied by N_t .

Loop Filter

The loop filter establishes the overall loop bandwidth, natural frequency and damping factor. These parameters determine the synthesizer lock-up time and spurious rejection ratio.

5-2.3 VCO SWITCHES AND DECODING

The supply voltage to each VCO is supplied by the switching logic which decodes the control information from the microprocessor. The switching voltage also selects the correct harmonic filter. The output from the synthesizer is switched from the receiver to the input of the transmitter by switches controlled by the PTT line.

5-3 DETAILED THEORY OF OPERATION

VCOs

Four separate VCO's cover the frequency range in four different bands:

Band A	30-39.975 MHz
Band B	40-51.975 MHz
Band C	52-67.975 MHz
Band D	68-87.975 MHz

The VCO's are selected by switching the supply voltage. The oscillator design uses dual-gate MOSFETs, Q12 to Q15, operating in the Hartley configuration. This design ensures excellent spectral purity. The source of the MOSFET is connected to a tap on the tuning inductor. The tuning inductor is made up of two series coils with the junction of the two coils used as the tap. The oscillator tuned circuit is tuned by the varactor diodes (D15 to D18). These diodes change capacitance in the inverse ratio to the applied back bias or tuning voltage. The tuning voltage is derived from the phase detector and locks the oscillator to the exact multiple of the reference frequency.

Frequency Modulation

In the transmit mode it is necessary to frequency modulate the transmitter. It is possible to frequency modulate the VCO by superimposing the audio signal on the tuning voltage from the phase detector. The transmitter audio is applied through R7 directly to the loop. This simple system gives very linear, low-distortion frequency modulation.

Buffer Amplifiers

The amplifiers are used to ensure that the VCO is completely isolated from any loading effects, as well as raise the output signal level to approximately +3 dBm. Transistors Q16 and Q17 are used as capacitively-coupled broadband amplifiers and the broadband transformer is used at the output to give the correct impedance match.

Harmonic Filters

The three-pole, low-pass Chebishev filters operate in the same frequency bands as the VCO's. When the supply voltage is switched to the VCO, the appropriate filter is switched into circuit by the appropriate diodes at the input and output of the filter.

Divide 32/33 Prescaler

The output from the synthesizer is coupled into the transistor buffer Q20 and then into the input of the prescaler U4. The prescaler divides the synthesizer output frequency by either 32 or 33 according to the input level on the modulus control line pin 1. The divided output is connected to the input of the phase detector in the synthesizer.

Synthesizer Operation

The synthesizer contains a selectable ratio divider coupled to the internal reference oscillator. The oscillator is controlled by Y1, a stable quartz crystal using the thermistor RT1 and C13 (a negative-temperature-coefficient capacitor) to stabilize the frequency over a wide temperature range. The program pins 1 and 20 are connected to the supply. This makes the divide ratio 256 and gives a reference frequency of 25 kHz which is internally coupled to the phase comparator.

The seven-bit programmable divide-by-A counter acts as a dual-modulus counter programmed to instruct in the prescaler when to divide by 33. The internal input lines from the latch are programmed with a binary number from 0 to 31. The 10-bit programmable divide-by-N counter is the main loop divider. It is programmed by the input lines from the internal latch. Since the VCO output is determined by:

$$F_{out} = N_t F_{ref} = N_t \times 25 \text{ kHz}$$

and by the technique of dual-modulus prescaling,

$$N_t = 32N + A$$

where,

N = binary number programmed into the N counter

A = binary number programmed into the A counter

therefore, the output frequency is determined by:

$$F_{out} = (32N + A) \times 25 \text{ kHz.}$$

An example of this follows:

1. The divide ratio is 2200 (determined by the selected channel frequency).
2. $F_{out} = 2200 \times 25 \text{ kHz} = 55.00 \text{ MHz}$
3. $2200 = 32N + A$
 $= 68, A = 24$
4. During one count, the prescaler operates at + 32 for 44 counts and + 33 for 24 counts.

5. This gives the following division ratio:
 $(32 \times 44) + (33 \times 24) = 2200$
6. The N counter is programmed with the binary equivalent of 68.
7. The A counter is programmed with the binary equivalent of 24.
8. The conversion of the frequency into the required binary numbers to program the counters is done in the microprocessor.

Programming

The synthesizer is programmed by a clocked, serial-input, 19-bit data stream. The data stream programs the internal 7-bit, 10-bit and 2-bit shift registers. When the registers are loaded, the latches are enabled and the A and N counters are programmed. The 2-bit latch is used to select the correct VCO. Transistors Q8 to Q11 are connected to the 2-bit latch to form a 4-port binary decoder. These transistors in turn drive the switching transistors Q3 to Q6, which switch the supply voltage to the VCO's and to the filter-selection diodes.

Loop Filter

The loop filter determines the overall natural frequency and damping factor of the PLL. These in turn, are instrumental in determining the synthesizer response time, close-in noise suppression, and reference-frequency side-band rejection. The loop filter consists of R11, C6, R12, C7, R13 & C8. The three-stage amplifier uses dual-gate MOSFET with the signal fed into both gates, followed by PNP and NPN transistors connected as a complimentary pair.

This configuration was chosen in place of the more common operational amplifier to reduce current drain. The output of the loop filter is a tri-state error voltage which is fed to the VCO varactor. Initially when the loop is unlocked, the output is a filtered pulse whose amplitude is corrected once every reference frequency cycle (25 kHz), and tends to drive the VCO toward the programmed frequency. When the loop is locked, the output is a dc voltage corresponding to that necessary to hold the VCO varactor to the proper capacitance for the programmed oscillator frequency.

Synthesizer Output Switching

The output from the synthesizer is switched between the transmitter and receiver modules. D13 switches the output to the receiver and D14 to the transmitter. The anodes of these diodes are at +10 V and conduct when either R65 or R63 are grounded through the transistor switches Q18 and Q19. When the PTT line is open (RX mode), Q18 is forward biased and the collector goes low, which switches off Q19. When the PTT line is closed, the bias to Q18 is shorted, the collector goes high, and Q19 is forward biased through R64.

Voltage Regulators

The synthesizer uses regulated 10-V and 5-V supplies. The regulators are chosen to have low residual current drain

and the 10-V regulator must operate with a small voltage differential to provide regulation when the battery voltage is low. Both regulators use U5, an integrated-circuit 5-V reference diode, as the voltage reference. The regulator is a dual low-power operational amplifier U3. The 5-V supply for U1 is supplied by U3A which uses U5 as a reference. The 10-V supply consists of U3B and the pass transistor Q2. The reference for one input of U3B is the voltage reference U5, and the other input derives its reference from the voltage divider R4/R5. This divider network establishes the output of U3B at 10 V.

Loss of Lock

If the synthesizer should not lock on frequency, the free-running VCO would cause the transmitter to operate on the wrong frequency. The synthesizer chip contains a loss-of-lock detector with the output at pin 9. The output pulses low when the loop is out of lock and forward biases Q1. The output of this device inhibits the transmit function.

5-4 VOLTAGE CHARTS

Table 5-1 shows dc voltage levels at the pins of the M2 transistors and IC's.

5-5 TEST AND ALIGNMENT

Module Test

The M2 module test is defined in TWC document #991436. This procedure requires the use of a special test fixture and is not described in this manual.

Alignment

The following special software instructions **MUST** be carefully noted when changing the M2 modules in a radio or repairing the M2 module. The PRC1077 operating-system software is contained in U6 in the M3A module. There are different types of software depending on the grade of varactor used in both the M2 and M5 modules. Table 5-2 shows the PRC1077 configurations based on varactor type (color code) used. Note that the -204 software is the standard configuration of radios built after February 1, 1989.

The variable inductors in each of the four filters following the VCO's are adjusted at the factory for best filtering and lock range of the synthesizer. Alignment of the coils without a proper test fixture is difficult; however, an approximate method is as follows:

- A. Remove the cores in L4 and L11. Adjust the cores in L9, L10 and L12 to the top of the coil. Adjust the cores in L1, L2, L3, L5, L6, L7 and L8 to the bottom of the coil (be careful not to jam the cores down).
- B. Check that the synthesizer locks at 68.000 MHz.
- C. Check that the synthesizer locks at 87.975 MHz; if it does not, adjust L7 upwards until it does lock.
- D. Repeat for the other three bands as noted in Table 5-3. Vary the appropriate VCO-ADJ coil until synthesizer lock is achieved at all frequencies.

**TABLE 5-1.
M2 Module Dc Voltages.**

<u>LOCATION</u>				<u>VOLTAGE</u>				<u>LOCATION</u>				<u>VOLTAGE</u>			
<u>M2J1</u>								<u>U1</u>							
PIN	RX	TX		PIN	RX	TX		PIN	RX	TX		PIN	RX	TX	
1	—	—		1	5.0	5.0		1	5.0	5.0		11	—	—	
2	—	—		2	—	—		2	—	—		12	—	—	
3	—	—		3	5.0	5.0		3	5.0	5.0		13	—	—	
4	—	—		4	5.0	5.0		4	5.0	5.0		14	5.0	0.0	
5	—	—		5	—	—		5	—	—		15	—	—	
6	2.7	2.9		6	5.0	5.0		6	—	—		16	—	—	
7	—	—		7	5.0	5.0		7	5.0	5.0		17	2.3	2.3	
8	13.5	13.5		8	5.0	5.0		8	5.0	5.0		18	2.3	2.3	
9	13.5	0.0		9	9.5	9.5		9	9.5	9.5		19	2.3	2.3	
10	—	—		10	13.8	13.8		10	13.8	13.8		20	5.0	5.0	

<u>U2</u>	PIN	RX	TX	<u>U3</u>	PIN	RX	TX
	1	—	—		1	5.0	5.0
	2	1.6	1.7		2	5.0	5.0
	3	1.6	1.7		3	5.0	5.0
	4	—	—		4	—	—
	5				5	5.0	5.0
	6	1.6	1.7		6	5.0	5.0
	7	10.0	10.0		7	9.5	9.5
	8	4.5	4.5		8	13.8	13.8

<u>U4</u>	PIN	RX	TX
	1	—	—
	2	—	—
	3	—	—
	4	—	—
	5	—	—
	6	—	—
	7	—	—
	8	—	—

**TABLE 5-1.
M2 Module Dc Voltages, Continued.**

<u>LOC.</u>	<u>VOLTAGE</u>		<u>LOC.</u>	<u>VOLTAGE</u>		<u>LOC.</u>	<u>VOLTAGE</u>		<u>Q4, Q5, Q6</u>
<u>Q1</u>	<u>RX</u>	<u>TX</u>	<u>Q2</u>	<u>RX</u>	<u>TX</u>	<u>Q3</u>	<u>RX</u>	<u>TX</u>	
C	—	—	C	10.0	10.0	C	0.0	10.0	Same as Q3 when selected.
B	—	—	B	9.5	9.5	B	10.0	10.0	
E	5.0	5.0	E	10.0	10.0	E	10.0	10.0	
<u>Q7</u>	<u>RX</u>	<u>TX</u>	<u>Q8</u>	<u>RX</u>	<u>TX</u>	<u>Q9-Q11</u>			
C	5.0	5.0	C	10.0	10.0	Same as Q8 when selected.			
B	—	—	B	5.0	5.0				
E	—	—	E	5.0	4.5				
<u>Q12</u>	<u>RX</u>	<u>TX</u>	<u>Q13</u>	<u>Q14</u>	<u>RX</u>	<u>TX</u>	<u>Q15</u>		
S	0.0	9.60	Same as Q12 when selected.	S	0.0	9.54	Same as Q14 when selected.		
G ₁	0.0	2.66		G ₁	0.0	2.50			
G ₂	—	—		G ₂	—	—			
D	—	—		D	—	—			
<u>Q16</u>	<u>RX</u>	<u>TX</u>	<u>Q17</u>	<u>RX</u>	<u>TX</u>	<u>Q18</u>	<u>RX</u>	<u>TX</u>	
C	0.9	—	C	10.13	10.13	C	0.1	9.0	
B	0.7	—	B	1.70	—	B	0.6	0.1	
E	—	—	E	1.10	1.10	E	—	—	
<u>Q19</u>	<u>RX</u>	<u>TX</u>	<u>Q20</u>	<u>RX</u>	<u>TX</u>				
C	10.0	0.1	C	0.9	0.8				
B	0.1	0.6	B	0.9	0.8				
E	—	—	E	—	—				

E. Adjusting for correct deviation requires a deviation meter for proper accuracy. Switch through all the noted frequencies while keying the PTT switch on each of the channels and putting in a 1-kHz tone. Find the channel with the highest deviation. Adjust the DEVIATION REF control on the high-deviation channel until the deviation meter reads 11 kHz. **Do not move the deviation ref control again for this module.**

F. Test all the other CH-select channels to confirm that their deviation is between 8-11 kHz. If the deviation is low on a channel, adjust the appropriate VCO adjustment coil (see Table 5-3) upward until it meets the 8- to 11-kHz specification.

In order to set the correct **output level** for each VCO, follow the procedure outlined below:

A. Switch through all the channel frequencies, while keying the PTT line on each of these channels. Adjust the FILTER adjustment coils for each Band (see Table 5-3) until the output is a minimum of 400 mV p-p and the output at the end of each VCO band is equal.

B. Switch through all the channel frequencies and confirm that the frequency counter shows the appropriate RX frequency for each channel as shown in Table 5-3. Observe that the output is a minimum of 400 mV p-p output on all the channels.

**TABLE 5-2.
Software Configuration vs. Varactor Type.**

Configuration A uses "205" software. Configuration B uses "204" software. Configuration C uses "203" software.* Configuration D uses "202" software.* * = Not Current			
VARACTOR GRADE USED IN <u>M5</u>: BAND 1 (D2-D9) BAND 2 (D12-D15) BAND 3 (D18-D21) BAND 4 (D24-D27)	VARACTOR GRADE USED IN <u>M2</u>: BAND 1 (D15) BAND 2 (D16) BAND 3 (D17) BAND 4 (D18)	M3B PCB REV LEVEL USED (738007):	M3A SOFTWARE REV LEVEL USED (U6):
1. BROWN, GREEN, BLUE, RED, GRAY, YELLOW or WHITE can be used in all bands. 2. PURPLE can be used in bands 1,2,3 and any color in band 4.	1. YELLOW, BROWN, GREEN, RED or PURPLE can be used in all bands. Do not mix.	1. Use 738007, Rev. E, fit link 1 and remove R42.	1. 205 <div style="border: 1px solid black; padding: 2px; display: inline-block;">A</div>
1. YELLOW, WHITE RED, GREEN, BLUE or ORANGE can be used in all bands. 2. PURPLE can be used in bands 1,2,3 and ORANGE in band 4.	1. YELLOW, BROWN, GREEN, RED or PURPLE can be used in all bands. Do not mix.	1. Use 738007, Rev. E, and do not fit link 1 or link 2.	1. 204 <div style="border: 1px solid black; padding: 2px; display: inline-block;">B</div>
1. YELLOW, WHITE RED, GREEN, BLUE or ORANGE can be used in all bands. 2. PURPLE can be used in bands 1,2,3 and ORANGE in band 4.	1. BROWN, GREEN, BLUE, RED, GRAY, YELLOW or WHITE can be used in all bands. Do not mix.	1. Use 738007, Rev. E, and do not fit link 1 or link 2.	1. 203 <div style="border: 1px solid black; padding: 2px; display: inline-block;">C</div>
1. BROWN, GREEN, BLUE, RED, GRAY, YELLOW or WHITE can be used in all bands. 2. PURPLE can be used in bands 1,2,3 and any other color in band 4.	1. BROWN, GREEN, BLUE, RED, GRAY, YELLOW or WHITE can be used in all bands. Do not mix.	1. Use 738007, Rev. D or 2. Use 738007, Rev. E, and fit Link 1 and Remove R42.	1. 202 <div style="border: 1px solid black; padding: 2px; display: inline-block;">D</div>
NOTE: If it is ever necessary to COMPLETELY change a 738007, Rev. E, back to a Rev. D: 1. Fit both Link 1 and Link 2. 2. Remove R42 and D7.			

**TABLE 5-3.
VCO/Filter Band Adjustments and Band Frequencies.**

CH SELECT	VCO-BAND	TX FREQ. (MHz)	VCO-ADJ	FILTER-ADJ	RX FREQ.(MHz)
1	4	87.975	L7	L12	77.275
2	4	78.500	L7	L12	67.800
3	4	68.000	L7	L12	57.300
4	3	67.975	L5	L11	57.275
5	3	59.500	L5	L11	48.800
6	3	52.000	L5	L11	41.300
7	2	51.975	L3	L10	62.675
8	2	46.500	L3	L10	57.200
9	2	40.000	L3	L10	50.700
10	1	39.975	L1	L9	50.675
11	1	34.500	L1	L9	45.200
12	1	30.000	L1	L9	40.700

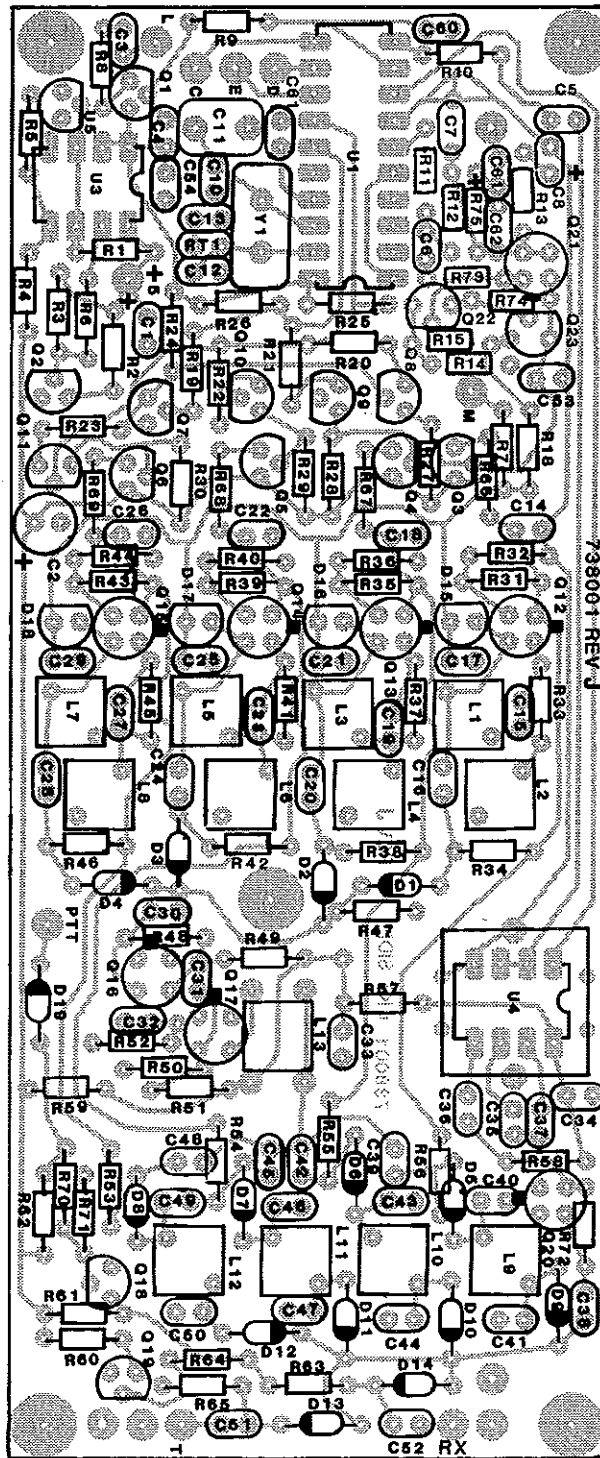
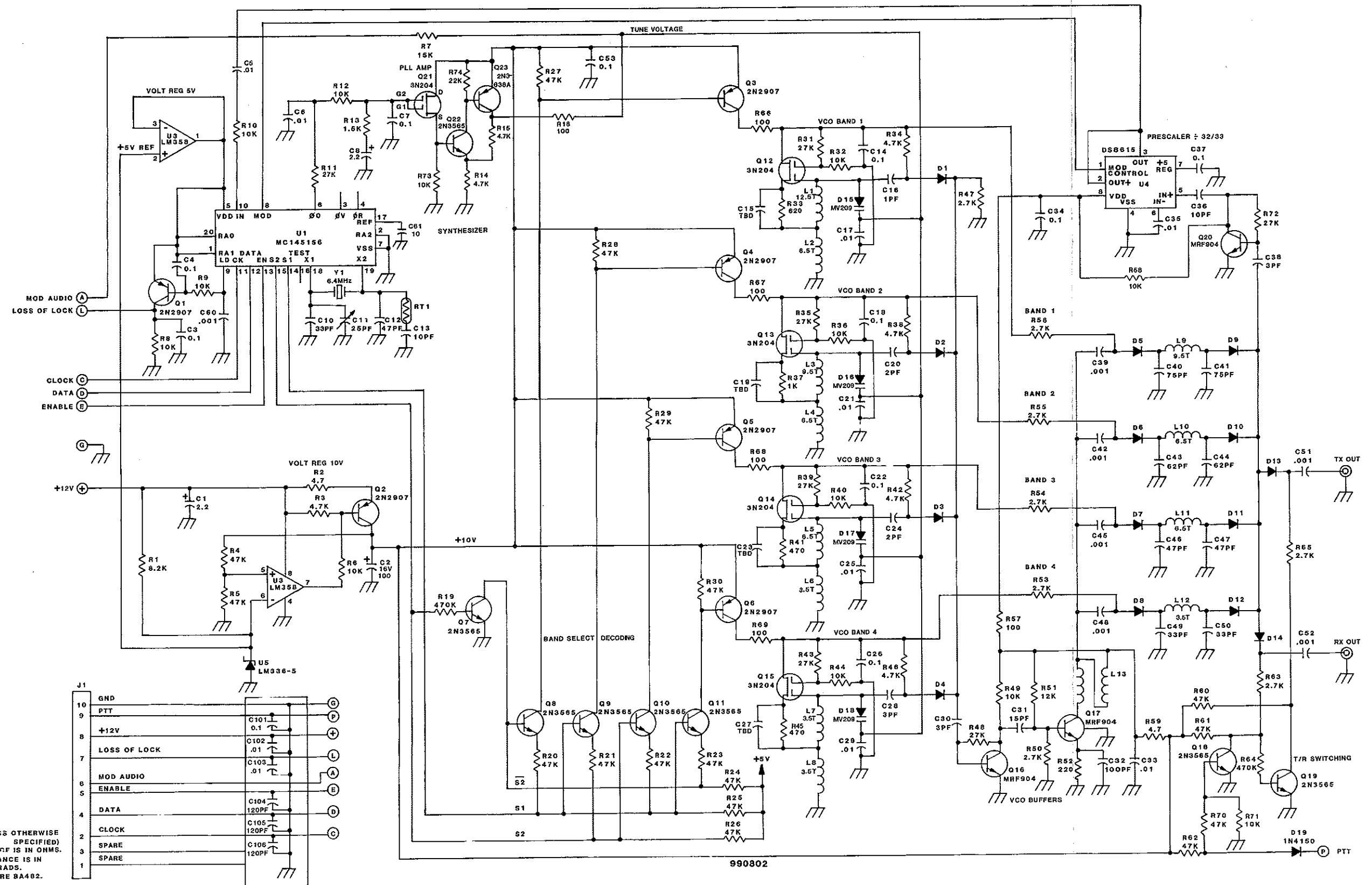

FIGURE 5-2.
Component Locations, Synthesizer Module, M2.



NOTES: (UNLESS OTHERWISE SPECIFIED)
 1. RESISTANCE IS IN OHMS.
 2. CAPACITANCE IS IN MICROFARADS.
 3. DIODES ARE BA482.

FIGURE 5-3. Schematic Diagram, Synthesizer Module, M2.

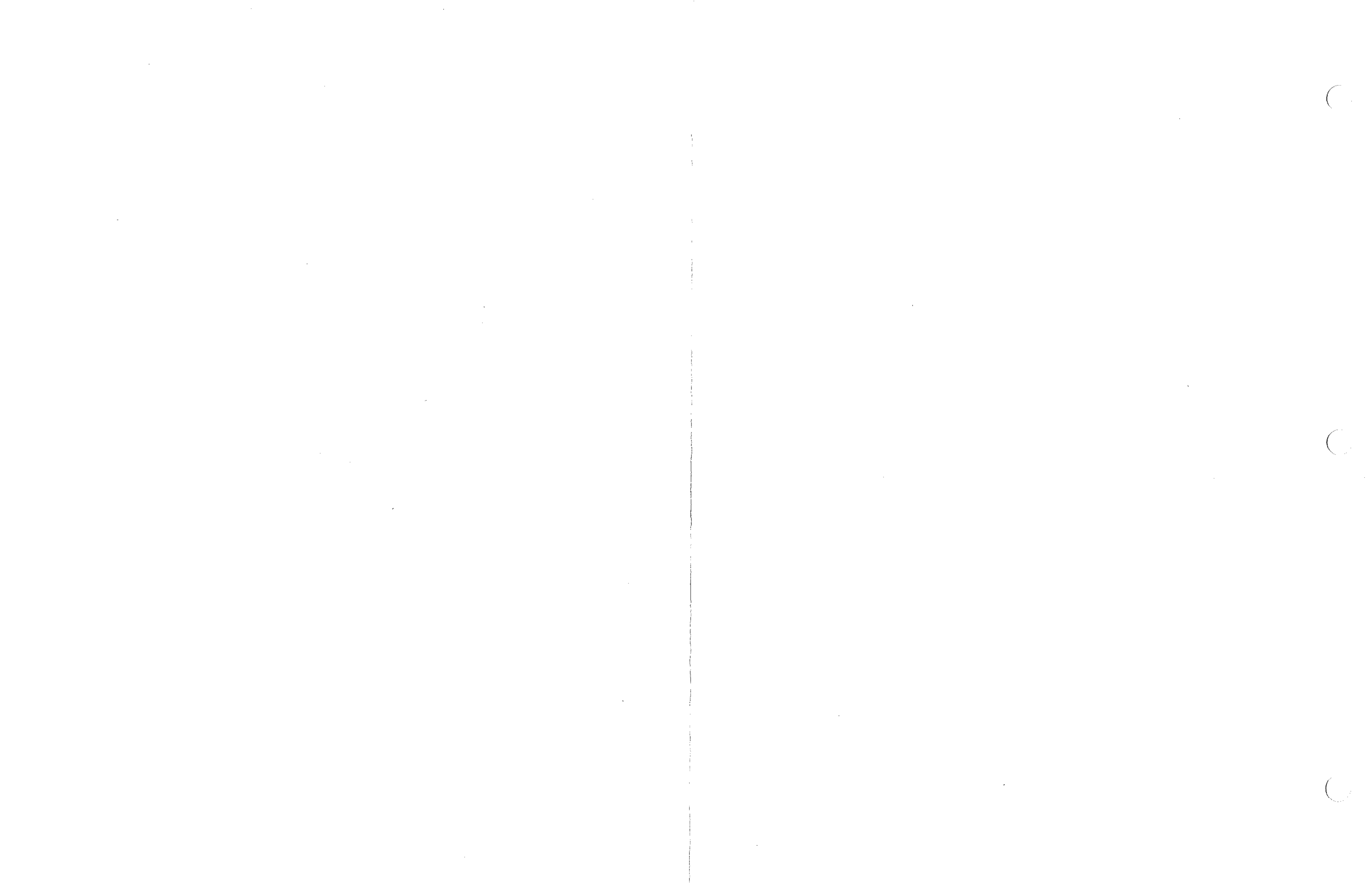

TABLE 5-4.
Parts List, Synthesizer Module, M2.

C1	241020	Capacitor, Tantalum 2.2 μ F
C2	237101	Capacitor, Electrolytic 16 V 100 μ F
C3,C4	275104	Capacitor, Monolithic 50 V 0.1 μ F
C5,C6	214103	Capacitor, Monolithic 50 V 0.01 μ F
C7	275104	Capacitor, Monolithic 0.1 μ F
C8	241020	Capacitor, Tantalum 2.2 μ F
C9		Not Used.
C10	221430	Capacitor, Mica DM5 43 pF
C11	261250	Capacitor, Trimmer 1-25 pF
C12	221470	Capacitor, Mica DM5 47 pF
C13	210100	Capacitor, Disc NPO 10 pF
C14	275104	Capacitor, Monolithic 50 V 0.1 μ F
C15		Not Used.
C16	210010	Capacitor, Disc NPO 1 pF
C17	214103	Capacitor, Monolithic 50 V 0.01 μ F
C18	275104	Capacitor, Monolithic 50 V 0.1 μ F
C19		Not Used.
C20	210020	Capacitor, Disc NPO 2 pF
C21	214103	Capacitor, Monolithic 50 V 0.01 μ F
C22	275104	Capacitor, Monolithic 50 V 0.1 μ F
C23		Not Used.
C24	210020	Capacitor, Disc NPO 2 pF
C25	214103	Capacitor, Monolithic 0.01 μ F
C26	275104	Capacitor, Monolithic 0.1 μ F
C27		Not Used.
C28	210030	Capacitor, Disc NPO 3 pF
C29	214103	Capacitor, Monolithic 50 V 0.01 μ F
C30	210030	Capacitor, Disc NPO 3 pF
C31	210150	Capacitor, Disc NPO 15 pF
C32	221101	Capacitor, Mica DM5 100 pF
C33	214103	Capacitor, Monolithic 50 V 0.01 μ F
C34	275104	Capacitor, Monolithic 50 V 0.1 μ F
C35	214103	Capacitor, Monolithic 50 V 0.01 μ F
C36	210100	Capacitor, Disc NPO 10 pF
C37	275104	Capacitor, Monolithic 50 V 0.1 μ F
C38	210030	Capacitor, Disc NPO 3 pF
C39	210102	Capacitor, Disc 0.001 μ F
C40,C41	221750	Capacitor, Mica DM5 75 pF
C42	210102	Capacitor, Disc 0.001 μ F
C43,C44	221620	Capacitor, Mica DM5 62 pF
C45	210102	Capacitor, Disc 0.001 μ F
C46,C47	221470	Capacitor, Mica DM5 47 pF
C48	210102	Capacitor, Disc 0.001 μ F
C49,C50	210330	Capacitor, Disc NPO 33 pF
C51,C52	210102	Capacitor, Disc 0.001 μ F
C53	275104	Capacitor, Monolithic 50 V 0.1 μ F
C54-C56	210121	Capacitor, Disc 120 pF
C57,C58	214103	Capacitor, Monolithic 50 V 0.01 μ F
C59	275104	Capacitor, Monolithic 50 V 0.1 μ F
C60	210102	Capacitor, Disc 0.001 μ F
C61	210100	Capacitor, Disc NPO 10 pF
C62-100		Not Used.
C101	275104	Capacitor, Monolithic .1 μ F
C102,C103	214103	Capacitor, Monolithic 50 V 0.01 μ F
C104-C106	210121	Capacitor, Disc NPO 120 pF

TABLE 5-4.
Parts List, Synthesizer Module, M2, Continued.

D1-D14	320005	Diode, PIN BA482
D15-D18	320305B	Diode, MV209
D19	320002	Diode, IN4148
L1	490109	Inductor, Variable 12.5 turns
L2	490114	Inductor, Variable 6.5 turns
L3	490127	Inductor, Variable 9.5 turns
L4	490136	Inductor, Variable 6.5 turns
L5	490114	Inductor, Variable 6.5 turns
L6	490129	Inductor, Variable 3.5 turns
L7	490137	Inductor, Variable 3.5 turns
L8	490129	Inductor, Variable 3.5 turns
L9	490127	Inductor, Variable 9.5 turns
L10	490114	Inductor, Variable 6.5 turns
L11	490136	Inductor, Variable 6.5 turns
L12	490137	Inductor, Variable 3.5 turns
L13	459153	Inductor, Variable 3:2 turns
Q1-Q6	310052	Transistor, PNP PN2907A
Q7-Q11	310006	Transistor, NPN 2N3565
Q12-Q15	310001	Transistor, MFT 3N204
Q16,Q17	310040	Transistor, NPN MRF904
Q18,Q19	310006	Transistor, NPN 2N3565
Q20	310040	Transistor, NPN MRF904
Q21	310001	Transistor, MFT 3N204
Q22	310006	Transistor, NPN 2N3565
Q23	310007	Transistor, PNP 2N3638
R1	113822	Resistor, Film 1/8 W 5% 8.2 k Ω
R2	113047	Resistor, Film 1/8 W 5% 4.7 Ω
R3	113472	Resistor, Film 1/8 W 5% 4.7 k Ω
R4,R5	113473	Resistor, Film 1/8 W 5% 47 k Ω
R6	113103	Resistor, Film 1/8 W 5% 10 k Ω
R7	113153	Resistor, Film 1/8 W 5% 15 k Ω
R8-R10	113103	Resistor, Film 1/8 W 5% 10 k Ω
R11	113273	Resistor, Film 1/8 W 5% 27 k Ω
R12	113103	Resistor, Film 1/8 W 5% 10 k Ω
R13	113152	Resistor, Film 1/8 W 5% 1.5 k Ω
R14,R15	113472	Resistor, Film 1/8 W 5% 4.7 k Ω
R16,R17		Not Used.
R18	113101	Resistor, Film 1/8 W 5% 100 Ω
R19	113474	Resistor, Film 1/8 W 5% 470 k Ω
R20-R30	113473	Resistor, Film 1/8 W 5% 47 k Ω
R31	113273	Resistor, Film 1/8 W 5% 27 k Ω
R32	113103	Resistor, Film 1/8 W 5% 10 k Ω
R33	124621	Resistor, Film 1/4 W 5% 620 Ω
R34	113472	Resistor, Film 1/8 W 5% 4.7 k Ω
R35	113273	Resistor, Film 1/8 W 5% 27 k Ω
R36	113103	Resistor, Film 1/8 W 5% 10 k Ω
R37	113102	Resistor, Film 1/8 W 5% 1 k Ω
R38	113472	Resistor, Film 1/8 W 5% 4.7 k Ω
R39	113273	Resistor, Film 1/8 W 5% 27 k Ω
R40	113103	Resistor, Film 1/8 W 5% 10 k Ω
R41	113471	Resistor, Film 1/8 W 5% 470 Ω
R42	113472	Resistor, Film 1/8 W 5% 4.7 k Ω

TABLE 5-4.
Parts List, Synthesizer Module, M2, Continued.

R43	113273	Resistor, Film 1/8 W 5% 27 k Ω
R44	113103	Resistor, Film 1/8 W 5% 10 k Ω
R45	113471	Resistor, Film 1/8 W 5% 470 Ω
R46	113472	Resistor, Film 1/8 W 5% 4.7 k Ω
R47	113272	Resistor, Film 1/8 W 5% 2.7 k Ω
R48	113273	Resistor, Film 1/8 W 5% 27 k Ω
R49	113103	Resistor, Film 1/8 W 5% 10 k Ω
R50	113272	Resistor, Film 1/8 W 5% 2.7 k Ω
R51	113123	Resistor, Film 1/8 W 5% 12 k Ω
R52	113221	Resistor, Film 1/8 W 5% 220 Ω
R53-R56	113272	Resistor, Film 1/8 W 5% 2.7 k Ω
R57	113101	Resistor, Film 1/8 W 5% 100 Ω
R58	113103	Resistor, Film 1/8 W 5% 10 k Ω
R59	113047	Resistor, Film 1/8 W 5% 4.7 Ω
R60-R62	113473	Resistor, Film 1/8 W 5% 47 k Ω
R63	113272	Resistor, Film 1/8 W 5% 2.7 k Ω
R64	113474	Resistor, Film 1/8 W 5% 470 k Ω
R65	113272	Resistor, Film 1/8 W 5% 2.7 k Ω
R66-R69	113101	Resistor, Film 1/8 W 5% 100 Ω
R70	113473	Resistor, Film 1/8 W 5% 47 k Ω
R71	113103	Resistor, Film 1/8 W 5% 10 k Ω
R72	113273	Resistor, Film 1/8 W 5% 27 k Ω
R73	113103	Resistor, Film 1/8 W 5% 10 k Ω
R74	113223	Resistor, Film 1/8 W 5% 22 k Ω
RT1	350102	Thermistor 1 k Ω
U1	330146	IC, MC145156P
U2		Not Used.
U3	330081	IC, LM358N
U4	330135	IC, DS8615N-4
U5	330133	IC, LM336Z-5.0
Y1	360026	Crystal, HC18/U 6.4 MHz

C

C

C

CHAPTER 6

PROCESSOR MODULE, M3 - THEORY OF OPERATION

6-0 INTRODUCTION

The processor module contains a microprocessor and associated components to perform the control functions in the transceiver. These functions include the tuning of the synthesizer, harmonic-filter selection, modulation level, receiver tuning, antenna-tuner control and the LCD frequency display. The module makes extensive use of CMOS devices and is only activated briefly to perform control functions. In the standby mode the power drain is very low.

The processor module is constructed on two separate printed-circuit boards. M3A contains the microprocessor, latches, ROM and wake-up control. M3B contains D/A conversion for receiver tuning, band-select switching, transmitter switching control, reset clamp and voltage regulation. Instructions for accessing and removing the M3 module are given in Section 2-5.2.

6-1 MODULE INTERCONNECTIONS

The M3 module has the following interconnections with the transceiver. Note that there are seven distinct connectors on this module; their location is as mentioned.

Connector M3J1 (located on the far left at the front-panel side of the module - see Figure 1-3):

- Pin 1 Ground.
- Pin 2 Display clock line to M6J1-3; 0- to 5-V signal at 2.5 MHz.
- Pin 3 Data line to M6J1-2; 0- to 5-V signal.
- Pin 4 +5 Vdc, regulated, to M6J1-4.
- Pin 5 Spare.

Connector M3J2 (located second from left at the front-panel side of the module - see Figure 1-3):

- Pin 1 Latch "1" line to M7J1-8 and M4J1-4; a 5-V signal enabling the latching relays in the tuner and PA modules.
- Pin 2 Clock line to M2J1-2 (see section 5-1).
- Pin 3 Audio clock line to M1J2-11 (see section 4-1).
- Pin 4 Latch "0" line to M7J1-9 and M4J1-5; a 5-V signal disabling the latching relays in the tuner and PA module.
- Pin 5 Enable line to M2J1-5 (see section 5-1).

Connector M3J3 (located third from left at the front-panel side of the module - see Figure 1-3):

- Pin 1 Spare processor inputs.
- Pin 2 Spare processor inputs.
- Pin 3 Spare processor inputs.
- Pin 4 From position D1 on the front-panel S2 channel switch.
- Pin 5 Data line to M1J2-12 (see section 4-1).

- Pin 5 Data line to M2J1-4.
- (Cont.) Data line to M7J1-5.

Connector M3J4 (located fourth from left at the front-panel side of the module - see Figure 1-3).

- Pin 1 Channel set line to front-panel switch S6; normally open, grounded when depressed.
- Pin 2 From position D2 on the front-panel channel switch S2.
- Pin 3 From position D0 on the front-panel channel switch S2.
- Pin 4 From the "down" position on the front-panel "MHz" switch S5. Normally open, grounded when pressed down.
- Pin 5 T+ line; +12 Vdc in TX mode.

Connector M3J5 (located at far right at the front-panel side of the module - see Figure 1-3):

- Pin 1 From the "10-foot antenna" microswitch on the front-panel antenna connection. Normally open, grounded when a 10-foot antenna is screwed into the antenna mount.
- Pin 2 From the D3 position on the front-panel channel switch S2.
- Pin 3 From the "down" position on the front-panel "kHz" switch S4; normally open, grounded when pressed down.
- Pin 4 From the "up" position on the front-panel "kHz" switch S4; normally open, grounded when pressed up.
- Pin 5 From the "up" position on the front-panel "MHz" switch S5; normally open, grounded when pressed up.

Connector M3J6 (located parallel to the front panel at the front of module - see Figure 1-3):

- Pin 1 Ground.
- Pin 2 +5 Vdc, regulated.
- Pin 3 600-Hz line to M1J2-7 (see section 4-1).
- Pin 4 +12 Vdc, switched.
- Pin 5 TX (-) line to M7J1-2; provides the ground to activate the T/R relay in the M7 module when the PTT line is keyed (provided the synthesizer is locked).
- Pin 6 Loss-of-lock line to M2J1-7 (see section 5-1); inhibits keying the T/R relay in the M7 when the synthesizer is not locked.
- Pin 7 PTT line.

Connector M3J7 (located at rear of module—see Figure 1-3):

- Pin 1 Ground.
- Pin 2 TX band 4 to M4 J1-6; +12 Vdc when a frequency in frequency band 4 is selected, 0 V otherwise.

- Pin 3 TX band 3 to M4J1-7; +12 Vdc when a frequency in band 3 is selected, 0 volts otherwise.
- Pin 4 TX band 2 to M4J1-8; +12 Vdc when a frequency in band 2 is selected, 0 V otherwise.
- Pin 5 TX band 1 to M4J1-9; +12 Vdc when a frequency in band 1 is selected, 0 V otherwise.
- Pin 6 RX band 4 to M5J1-6; +12 Vdc when a frequency in band 4 is selected, 0 V otherwise.
- Pin 7 RX band 3 to M5J1-7; +12 Vdc when a frequency in band 4 is selected, 0 V otherwise.
- Pin 8 RX band 2 to M5J1-8; +12 Vdc when a frequency in band 2 is selected, 0 volts otherwise.
- Pin 9 RX band 1 to M5J1-9; +12 Vdc when a frequency in band 1 is selected, 0 V otherwise.
- Pin 10 RX+ to M5J1-2; +12 V, switched in receive mode.
- Pin 11 +12 Vdc, unswitched, from battery.
- Pin 12 Tune voltage to M5J1-4; used to program the receiver varactors (see Tables 6-2 and 6-3).

6-2 CIRCUIT DESCRIPTION

The module provides most of the control functions with a serial data stream. This means that all the control functions come from one port of the processor as a data stream instead of a large number of parallel ports. This information must be converted into parallel data or into analog information. The advantage of using serial data is that a single data bus and clock lines are used instead of a large number of parallel control lines. This has much reduced the wiring-harness complexity and the number of connectors in the transceiver. A good example is the control of the synthesizer, which would require 19 control lines to replace the single data bus, if parallel entry was required. The conversion of the data stream is achieved by shift registers which take the serial data stream, clock it through the registers and output the data in parallel form. These shift registers are located in the individual module requiring control. In the case of the synthesizer, the synthesizer chip contains its own internal shift registers and latches.

Microprocessor (M3A)

The microprocessor is combined with the ROM (read-only memory) and the input/output circuits to form a special purpose microcomputer. The theory of operation of the microprocessor is beyond the scope of this manual. Simply stated, the microprocessor controls the operation of the transceiver in response to the control inputs in accordance with the program stored in the memory.

The microprocessor operates at the clock frequency of 2.5 MHz using an internal oscillator controlled by the crystal Y1. The outputs from the microprocessor are D0 to D7 to the ROM and latches U4 and U5, ALE (address latch enable), and WE (write enable). INT (interrupt) and RESET are inputs from the M3B board. The input ports P10-17 are used for various control functions such as channel selection, frequency changing, etc. P21-23 connect to the ROM and P25-27 go to a connector for possible optional control functions.

ROM (Read Only Memory), (M3A)

The ROM U6 contains the permanent memory to control the operating functions of the transceiver. This includes the general operating system, specific programs to operate the synthesizer, display and channel selection, lookup tables containing instructions for the receiver tuning voltage, antenna tuning and modulation control. This device is programmed in the factory and replacements must contain the correct memory program. The ROM is connected to the microprocessor and uses the address latch U4 for interfacing.

Latch (M3A)

The latch U5 is used to output the multiplexed data and control information, including the main data bus, the different clock outputs, enable line and the latches controlling the latching relays.

Wake-up Control (M3A)

The microprocessor operates only during the period required to perform its specific control functions. This gives two important operational advantages. The first is that the processor only draws current during the brief period required to perform the control functions, typically only a few milliseconds. The second advantage is that there is no need to provide extensive shielding to stop noise in the receiver. The processor operates only when frequencies are changed and the receiver is muted while the frequency change is in progress.

The wake-up control is required to tell the microprocessor when inputs from the front panel are being operated. A parity tree, U2, is connected to the dual one shot, U3, which controls the interrupt line and instructs the microprocessor to wakeup and perform the control function. The parity tree is connected to all of the operational inputs to the microprocessor. When a signal is received from any of the panel controls or the T+ line (indicating change from transmit to receive), the interrupt line is immediately activated, switching the microprocessor on.

ROM Power Switch (M3A)

The ROM power switch (Q1) turns off the +5 V to the ROM to conserve power when the microprocessor is not operating.

Reset Clamp (M3B)

The magnesium battery often used with the transceiver takes an appreciable period of time to deliver power. It is quite normal for the battery voltage to start off at 12 V and then fall to a very low value when the transceiver is first switched on. The battery voltage will then gradually return to normal. This starting characteristic can cause the microprocessor to operate incorrectly and cause malfunctions in the transceiver. The reset clamp circuit Q4/5 detects the low voltage and forces the microprocessor to reset. C5 on M3A slows the rise of the reset pulse to ensure that the other circuitry in the processor has returned to normal.

Transmitter Switching (M3B)

The transmitter switching is controlled by grounding the Tx(-) line. The PTT line switches on Q1 which forward biases the base of Q3. If Q2 is forward biased by the loss of lock line, the PTT switching is inhibited.

Receiver Tune Voltage

The tune voltage for the varactors in the receiver front end is generated by the shift register U3 and the operational amplifier U2A used as a Digital/Analog converter. Resistors R25 to R30 are arranged in binary sequence to provide 64 tune voltage steps in each band.

Band-Select Switching

The four frequency bands are selected by the switching transistors Q9 to Q12. The outputs Q7/8 from the shift register U3 provide the binary switching information which is decoded by Q6 and Q13 to Q16 to drive the band select switching transistors.

Memory Backup

The internal RAM in the microprocessor is normally powered through the switch Q8 from the 5-V regulator. When the power is removed, the memory is sustained through D2 from the battery through a direct connection bypassing the main power switch. The lithium battery BT1 provides memory backup through D3 if the main battery is removed.

Voltage Regulator

The voltage regulator (5 V) uses the operational amplifier U2 driving the series pass transistor Q7. This circuit will operate with a small voltage differential and with very low current drain. The voltage reference is provided by the precision integrated circuit reference diode Q17. The potentiometer R20 is used to set the output voltage to exactly 5 V.

Tone Generator - 600 Hz (M3B)

The 600-Hz tone generator is used to provide a precision 600-Hz tone. The 600-Hz tone is further divided in the audio module to provide the 150-Hz tone for the transmitter and the control of the 150-Hz commutating filter in the receiver. U1 divides the 614.4-kHz reference signal by 1024 to provide the 600-Hz output. The oscillator in U1 is

controlled by Y1, a ceramic resonator which has similar properties to a quartz crystal.

6-3 VOLTAGE CHARTS

Table 6-1 is a voltage chart showing the dc levels on all M3 transistors and IC's.

6-4 TEST AND ALIGNMENT

Module Test

Both the M3A and M3B module tests are defined by TWC test procedures—M3A is #991470 and M3B is #991437. Both procedures require the use of special test fixtures and are not included in this manual.

Alignment

As was mentioned in Section 5-5, the software for the radio is contained in M3A-U6 and its configuration (either -202, -203, or -204) is dependent on the grade of tuning varactor used in the M2 and M5 modules.

The standard configuration uses -204 software; in this case links 1 and 2 are removed on the Rev. E PC boards and D7 and R42 are installed.

For Rev. E or Rev. D configurations (-202 or -205 software), i.e.:

1. Rev. D PCB's.
2. Rev. E PCB's (configured as fully circuit compatible with Rev. D PCB's).
3. Rev. E PCB's (configured as fully electrically compatible with Rev. D PCB's).

The following PCB configurations for the options listed above apply:

Option 1 - Rev. D boards.

Option 2 - PCB's have links 1 and 2 installed; R42 and D7 removed.

Option 3 - PCB's have link 1 and D7 installed; link 2 and R42 removed.

The tune voltages for -204 software configurations (as measured on M3J7-12) are given in Table 6-2.

The tune voltage for -202, or -205 software configurations are given in Table 6-3.

**TABLE 6-1.
M3 Voltage Charts.**

M3A											
<u>LOCATION</u>		<u>VOLTAGE</u>		<u>LOCATION</u>		<u>VOLTAGE</u>		<u>LOCATION</u>		<u>VOLTAGE</u>	
<u>J1</u>	PIN	RX	TX	<u>J2</u>	PIN	RX	TX	<u>J3</u>	PIN	RX	TX
	1	—	—		1	—	—		1	4.9	4.9
	2	—	—		2	—	—		2	4.9	4.9
	3	—	—		3	—	—		3	4.9	4.9
	4	4.9	4.9		4	—	—		4	4.9	4.9
	5	—	—		5	—	—		5	—	—

<u>J4</u>	PIN	RX	TX	<u>J5</u>	PIN	RX	TX	<u>M1</u>	PIN	RX	TX	PIN	RX	TX
	1	4.9	4.9		1	4.9	4.9		1	—	5.0	21	4.9	4.9
	2	4.9	4.9		2	4.9	4.9		2	4.1	4.1	22	—	—
	3	4.9	4.9		3	4.9	4.9		3	4.9	4.9	23	—	—
	4	4.9	4.9		4	4.9	4.9		4	4.9	4.9	24	—	—
	5	—	12.12		5	4.9	4.9		5	—	—	25	4.9	4.9
									6	4.9	4.9	26	4.9	4.9
									7	4.9	4.9	27	4.9	4.9
									8	4.9	4.9	28	4.9	4.9
									9	4.9	4.9	29	4.9	4.9
									10	4.9	4.9	30	4.9	4.9
									11	4.9	4.9	31	4.9	4.9
									12	—	—	32	4.9	4.9
									13	—	—	33	4.9	4.9
									14	—	—	34	4.9	4.9
									15	4.9	4.9	35	4.9	4.9
									16	4.9	4.9	36	4.9	4.9
									17	—	—	37	4.9	4.9
									18	4.9	4.9	38	4.9	4.9
									19	4.9	4.9	39	4.9	4.9
									20	—	—	40	4.9	4.9

<u>M2</u>	PIN	RX	TX	PIN	RX	TX
	1	4.9	4.9	9	4.9	—
	2	4.9	4.9	10	4.9	4.9
	3	4.9	4.9	11	4.9	4.9
	4	—	5.4	12	4.9	4.9
	5	4.9	4.9	13	4.9	4.9
	6	4.9	4.9	14	4.9	4.9
	7	—	—	15	4.9	4.9
	8	—	—	16	4.9	4.9

**TABLE 6-1.
M3 Voltage Charts, Continued.**

M3A													
<u>LOCATION</u>		<u>VOLTAGE</u>		<u>LOC.</u>	<u>VOLTAGE</u>		<u>LOCATION</u>		<u>VOLTAGE</u>		<u>LOC.</u>	<u>VOLTAGE</u>	
<u>M3</u>	PIN	RX	TX	PIN	RX	TX	<u>M4</u>	PIN	RX	TX	PIN	RX	TX
	1	—	—	9	4.9	4.9		1	—	—	11	4.9	4.9
	2	4.7	4.7	10	—	—		2	—	—	12	4.9	4.9
	3	4.9	4.9	11	4.9	—		3	—	—	13	4.9	4.9
	4	4.9	—	12	—	—		4	—	—	14	—	—
	5	4.9	4.9	13	4.9	4.9		5	4.9	4.9	15	4.9	4.9
	6	—	—	14	4.9	4.9		6	4.9	4.9	16	4.9	4.9
	7	4.9	4.9	15	—	—		7	—	—	17	—	—
	8	—	—	16	4.9	4.9		8	4.9	4.9	18	—	—
								9	4.9	4.9	19	—	—
								10	—	—	20	4.9	4.9
<u>M6</u>	PIN	RX	TX	PIN	RX	TX	<u>M5</u>	PIN	RX	TX	PIN	RX	TX
	1	4.9	4.9	13	4.9	4.9		1	—	—	11	4.9	4.9
	2	4.9	4.9	14	4.9	4.9		2	—	—	12	—	—
	3	—	—	15	—	—		3	4.9	4.9	13	—	—
	4	4.9	4.9	16	4.9	4.9		4	4.9	4.9	14	—	—
	5	4.9	4.9	17	4.9	4.9		5	—	—	15	—	—
	6	—	—	18	—	—		6	4.9	4.9	16	—	—
	7	—	—	19	—	—		7	4.9	4.9	17	—	—
	8	—	—	20	—	—		8	—	—	18	—	—
	9	—	—	21	4.9	4.9		9	—	—	19	—	—
	10	—	—	22	—	—		10	—	—	20	4.9	4.9
	11	—	—	23	4.9	4.9							
	12	—	—	24	0.16	0.16							
<u>Q1</u>	RX	TX											
C	0.16	0.16											
B	—	—											
E	4.9	4.9											

**TABLE 6-1.
M3 Voltage Charts, Continued.**

M3B

<u>LOCATION</u>		<u>VOLTAGE</u>		<u>LOCATION</u>		<u>VOLTAGE</u>		<u>LOC.</u>	<u>VOLTAGE</u>	
<u>J6</u>	PIN	RX	TX	<u>J7</u>	PIN	RX	TX	PIN	RX	TX
	1	—	—		1	—	—	7	—	—
	2	5.00	5.00		2	—	—	8	—	—
	3	2.48	2.48		3	—	—	9	13.5	13.0
	4	13.70	13.50		4	—	—	10	13.5	13.0
	5	13.70	0.2		5*	13.5	13.0	11	13.6	13.6
	6	—	—		6	—	—	12	1.9	1.9
	7	13.50	0.0							

* Band 1 selected.

<u>U1</u>	PIN	RX	TX	PIN	RX	TX	<u>U3</u>	PIN	RX	TX	PIN	RX	TX
	1	2.4	2.4	9	2.5	2.5		1	5.0	5.0	9	—	—
	2	2.4	2.4	10	2.5	2.5		2	—	—	10	—	—
	3	2.4	2.4	11	2.4	2.4		3	—	—	11	—	—
	4	2.4	2.4	12	—	—		4	5.0	5.0	12	—	—
	5	2.4	2.4	13	2.4	2.4		5	—	—	13	5.0	5.0
	6	2.4	2.4	14	2.4	2.4		6	—	—	14	5.0	5.0
	7	2.4	2.4	15	2.4	2.4		7	5.0	5.0	15	5.0	5.0
	8	—	—	16	5.0	5.0		8	—	—	16	5.0	5.0

<u>U2</u>	PIN	RX	TX	<u>Q1</u>	RX	TX	<u>Q3</u>	RX	TX
	1	1.90	1.90	C	0.0	13.0	C	13.7	0.2
	2	3.46	3.50	B	13.5	12.3	B	0.0	0.8
	3	3.40	3.40	E	13.5	13.0	E	—	—
	4	—	—						
	5	5.00	5.00	<u>Q2</u>	RX	TX	<u>Q4</u>	RX	TX
	6	5.00	5.00	C	0.0	0.8	C	—	—
	7	5.30	5.30	B	—	—	B	—	—

**TABLE 6-1.
M3 Voltage Charts, Continued.**

M3B

<u>LOC.</u>	<u>VOLTAGE</u>		<u>LOC.</u>	<u>VOLTAGE</u>		<u>LOC.</u>	<u>VOLTAGE</u>	
<u>Q5</u>	RX	TX	<u>Q6</u>	RX	TX	<u>Q7</u>	RX	TX
C	—	—	C	4.9	4.9	C	13.5	13.0
B	—	—	B	—	—	B	5.3	5.3
E	—	—	E	—	—	E	4.9	4.9
<u>Q8</u>	RX	TX	<u>Q9</u>	RX	TX	<u>Q10-Q12</u>	Same as Q9 when selected	
C	4.9	4.9	C	13.5	13.0			
B	—	—	B	12.7	12.3			
E	—	—	E	13.5	13.0			
<u>Q13</u>	RX	TX	<u>Q14-Q16</u>	Same as Q13 when selected		<u>Q18</u>	RX	TX
C	12.7	12.3				C	—	—
B	4.9	4.9				B	13.5	13.0
E	12.7	12.3				E	5.0	5.0

TABLE 6-2.
Tune Voltages for -203 or -204 Software Configurations.

FREQUENCY (MHz)	TUNE VOLTAGE	BAND SELECT
30.6	2.44	1
34.6	5.45	1
39.6	9.78	1
40.6	2.75	2
46.6	6.64	2
51.6	10.88	2
52.6	3.36	3
59.6	6.97	3
67.6	12.22	3
68.6	3.48	4
78.6	7.86	4
87.6	12.30	4

TABLE 6-3.
Tune Voltages for -202 Software.

FREQUENCY (MHz)	TUNE VOLTAGE	BAND SELECT
30.6	1.58	1
34.6	3.72	1
39.6	6.64	1
40.6	1.83	2
46.6	4.47	2
51.6	7.41	2
52.6	2.21	3
59.6	4.72	3
67.6	8.29	3
68.6	2.33	4
78.6	5.39	4
87.6	8.41	4

This page intentionally left blank.

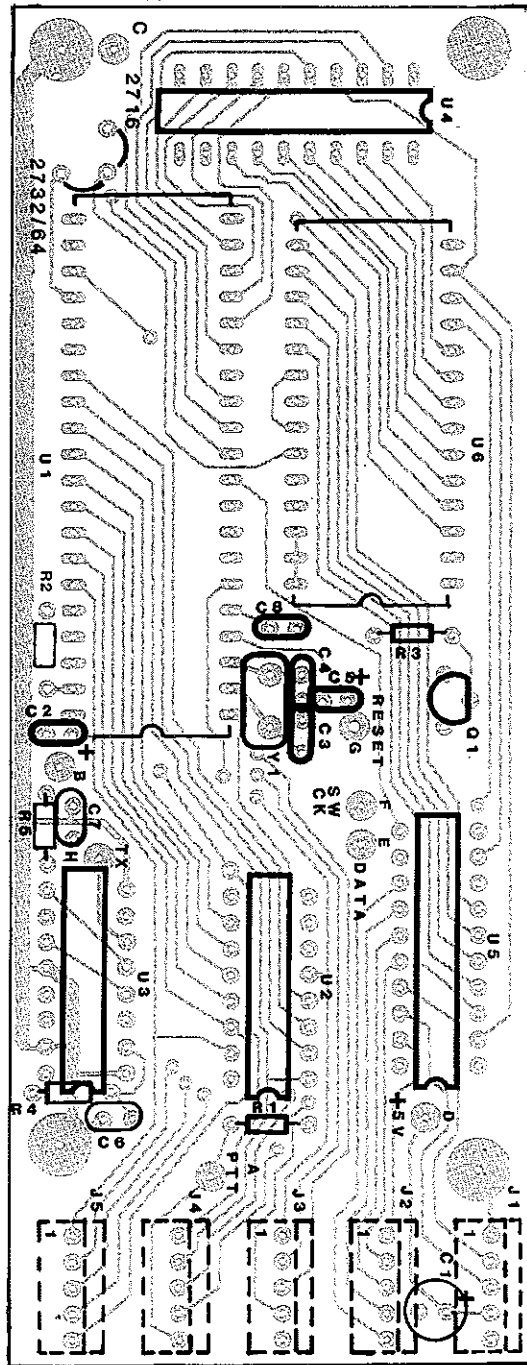
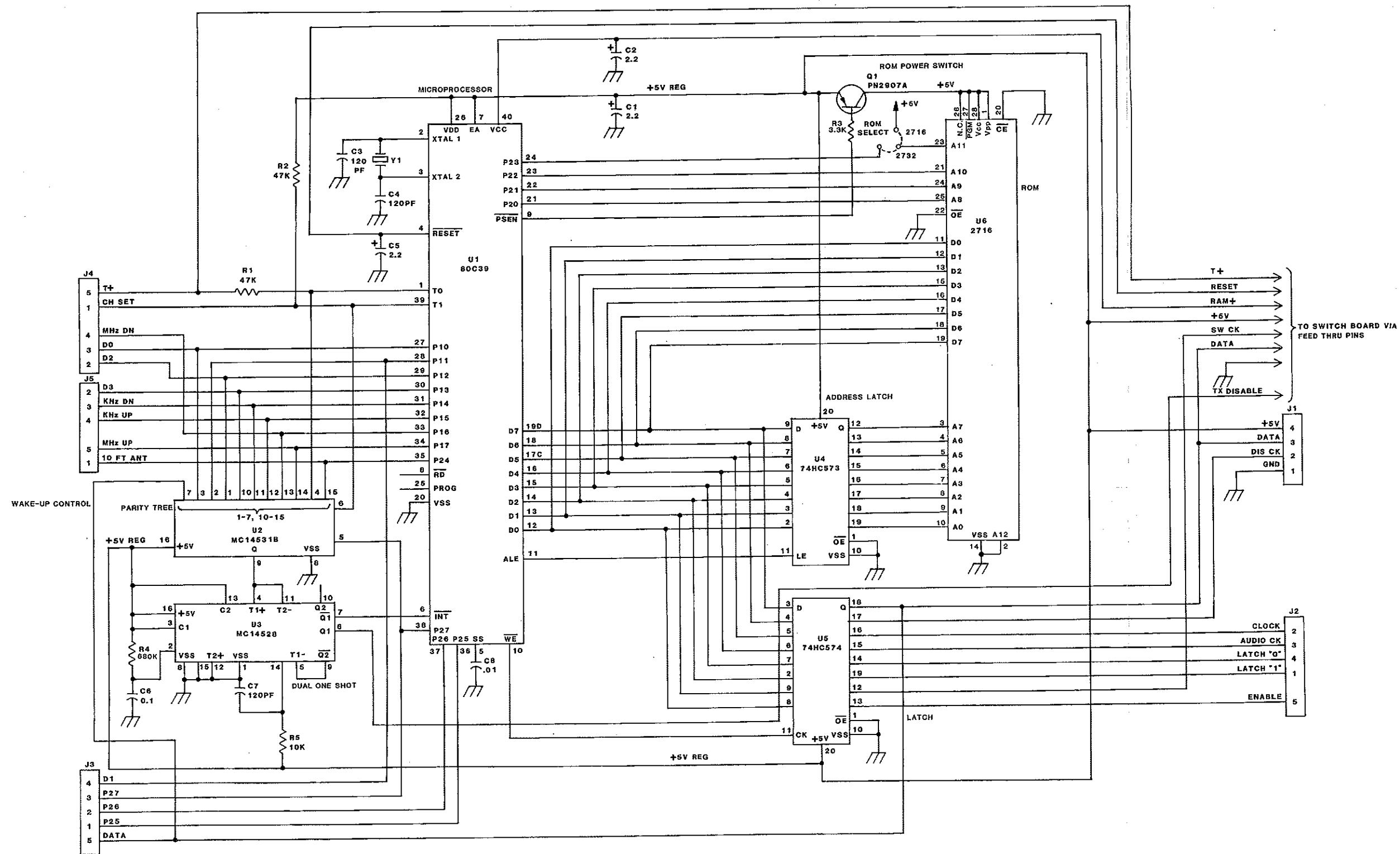

FIGURE 6-1.
Component Locations, Processor Module, M3A.



NOTES: (UNLESS OTHERWISE SPECIFIED)
 * RESISTANCE IS IN OHMS.
 2. CAPACITANCE IS IN MICROFARADS.

FIGURE 6-2. Schematic Diagram, Processor Module, M3A.

M3A

TABLE 6-4.
Parts List, Processor Module, M3A.

C1	241020	Capacitor, Tantalum 2.2 μ F
C2	241020	Capacitor, Tantalum 2.2 μ F
C3,C4	210121	Capacitor, Disc NPO 120 pF
C5	241020	Capacitor, Tantalum 2.2 μ F
C6	275104	Capacitor, Monolithic .1 μ F
C7	210121	Capacitor, Disc NPO 120 pF
C8	214103	Capacitor, Disc .01 μ F
Q1	310052	Transistor, PNP PN2907A
R1,R2	113473	Resistor, Film 1/8 W 5% 47 k Ω
R3	113332	Resistor, Film 1/8 W 5% 3.3 k Ω
R4	113684	Resistor, Film 1/8 W 5% 680 k Ω
R5	113103	Resistor, Film 1/8 W 5% 10 k Ω
U1	330142	IC, 80C39
U2	330130	IC, MC14531
U3	330115	IC, MC14528BCP
U4	330141	IC, 74HCT573
U5	330157	IC, 74HC574N
U6	330102	IC,UPD2716-6
Y1	363002	Resonator, Ceramic 2.5 MHz

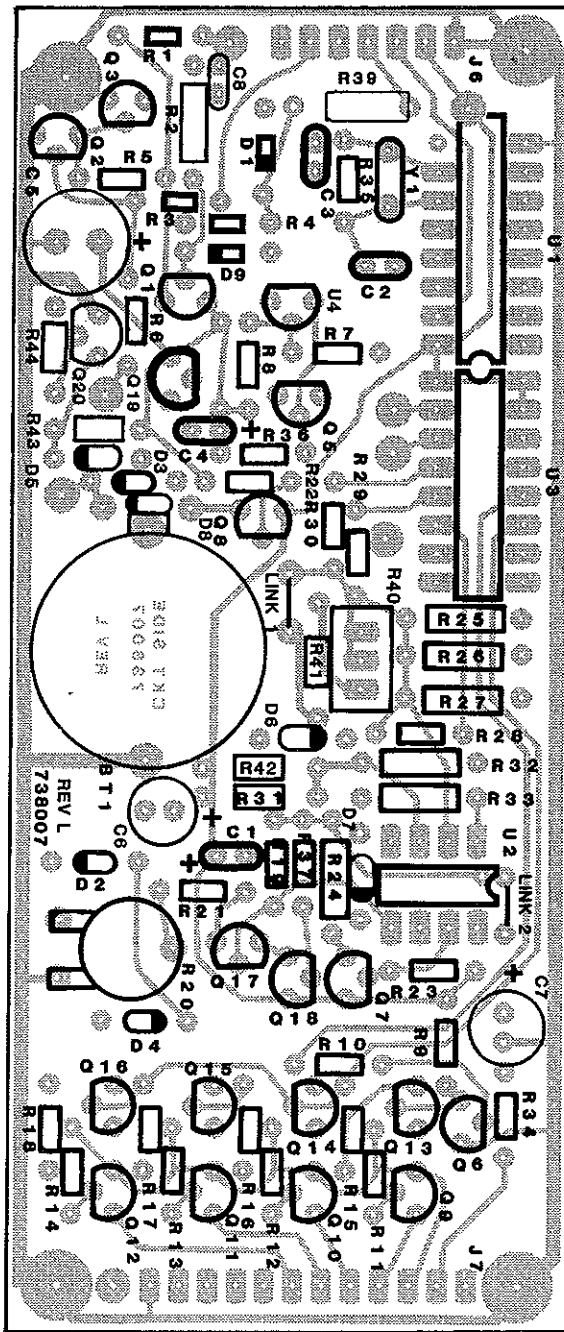

FIGURE 6-3.
Component Locations, Switch Module, M3B.

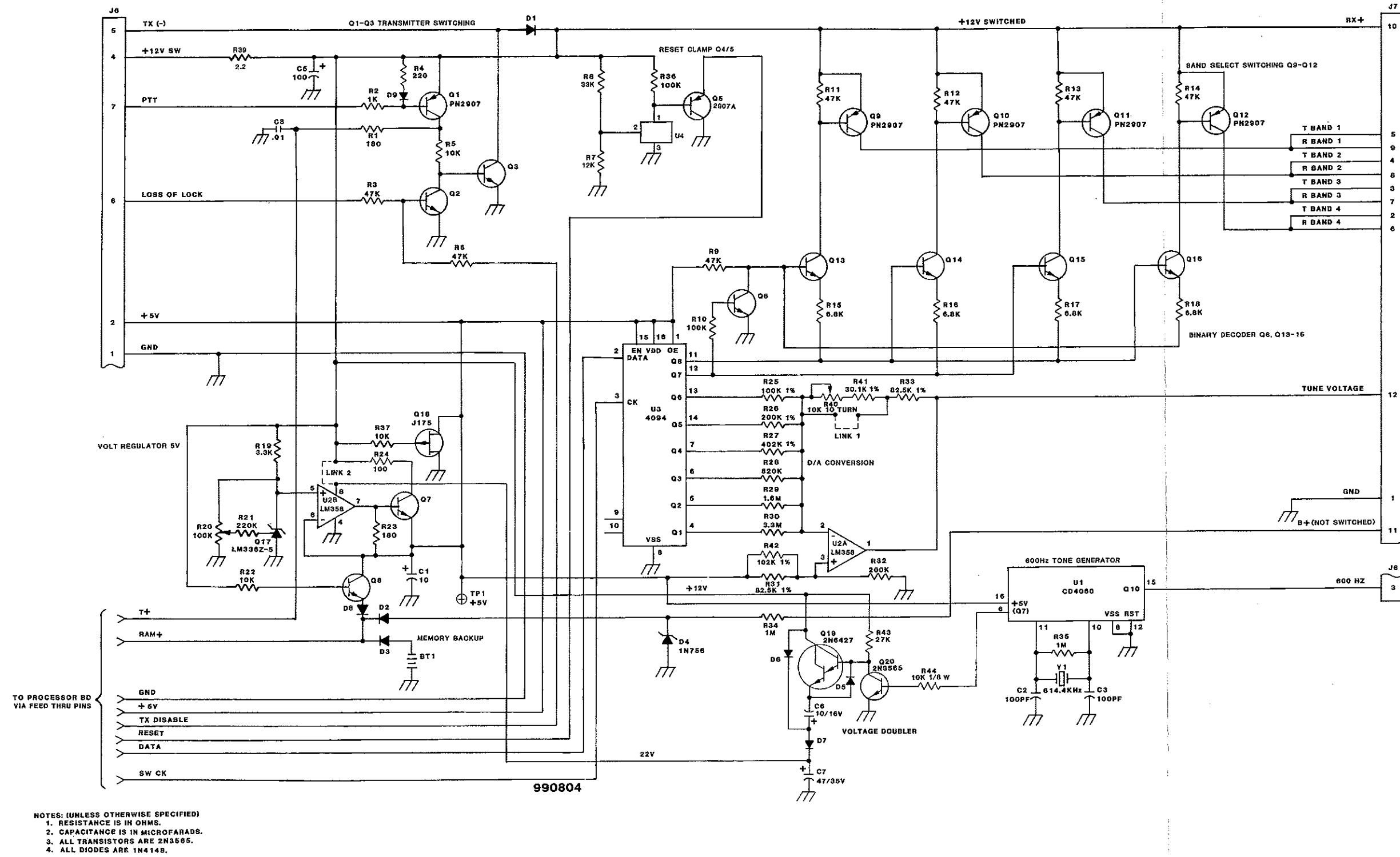

FIGURE 6-4. Schematic Diagram, Switch Module, M3B.

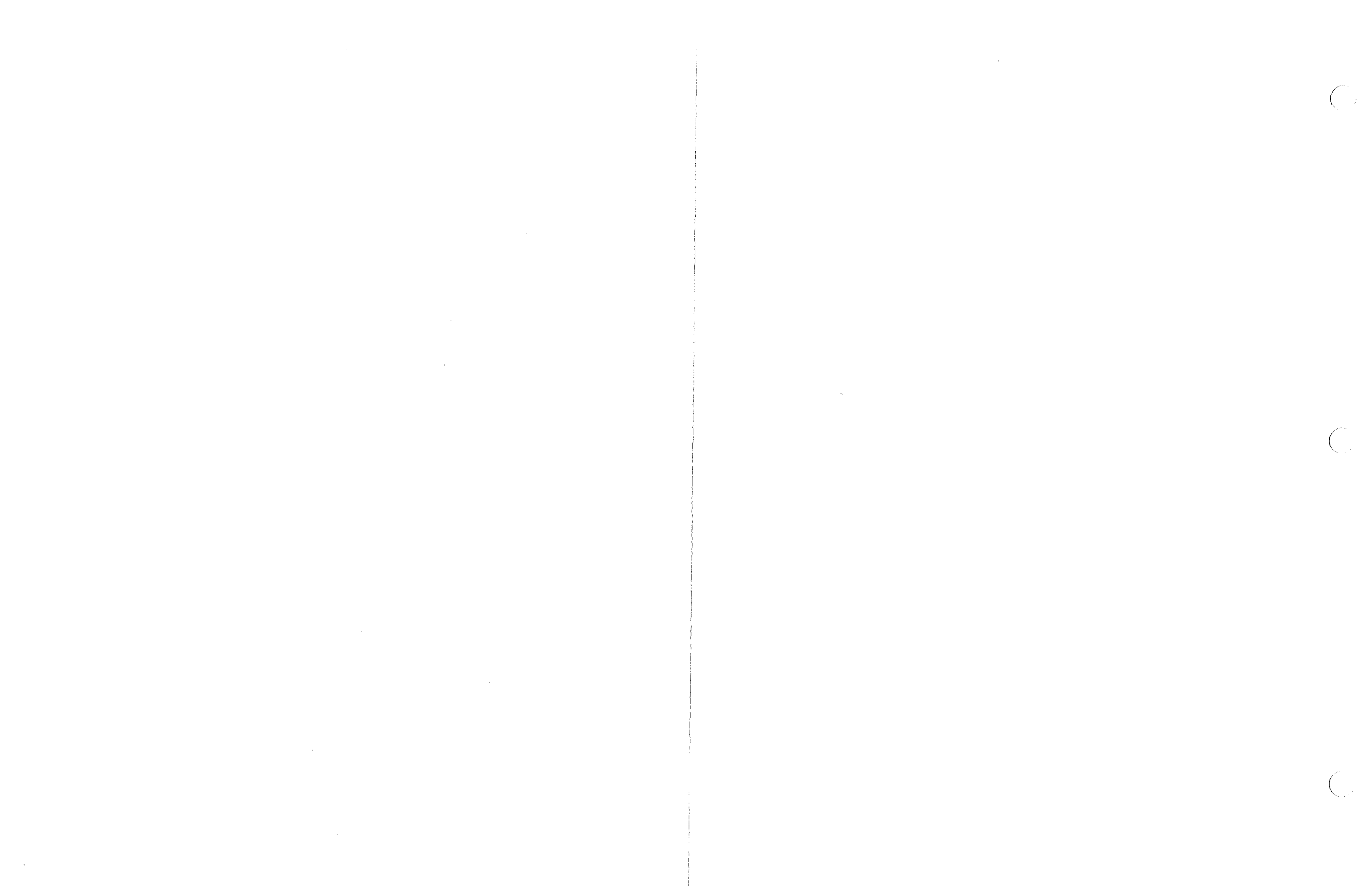

TABLE 6-5.
Parts List, Switch Module, M3B.

C1	241100	Capacitor, Tantalum 10
C2,C3	221101	Capacitor, Mica DM5 100 pF
C4		Not Used.
C5	231101	Capacitor, Electrolytic 16 V 100 μ F
C6	231100	Capacitor, Electrolytic 16 V 10 μ F
C7	234470	Capacitor, Electrolytic 35 V 47 μ F
C8	275104	Capacitor, Monolithic 50 V 0.1 μ F
D1-D3	320002	Diode, 1N4148
D4	320202	Diode, Zener 1N756
D5-D9	320002	Diode, 1N4148
Q1	310052	Transistor, PNP PN2907A
Q2-Q3	310006	Transistor, NPN 2N3565
Q4		Not Used.
Q5	310052	Transistor, PNP PN2907A
Q6-Q8	310006	Transistor, NPN 2N3565
Q9-Q12	310052	Transistor, PNP PN2907A
Q13-Q16	310006	Transistor, NPN 2N3565
Q17	330133	IC, LM336Z-5.0
Q18	310072	Transistor, J175
Q19	310064	Transistor, Darlington 2N6427
Q20	310006	Transistor, NPN 2N3565
R1	113181	Resistor, Film 1/8 W 5% 180 Ω
R2	124102	Resistor, Film 1/4 W 5% 1 k Ω
R3	113473	Resistor, Film 1/8 W 5% 47 k Ω
R4	113221	Resistor, Film 1/8 W 5% 220 Ω
R5	113103	Resistor, Film 1/8 W 5% 10 k Ω
R6	113473	Resistor, Film 1/8 W 5% 47 k Ω
R7	113123	Resistor, Film 1/8 W 5% 12 k Ω
R8	113333	Resistor, Film 1/8 W 5% 33 k Ω
R9	113473	Resistor, Film 1/8 W 5% 47 k Ω
R10	113104	Resistor, Film 1/8 W 5% 100 k Ω
R11-R14	113473	Resistor, Film 1/8 W 5% 47 k Ω
R15-R18	113562	Resistor, Film 1/8 W 5% 5.6 k Ω
R19	113332	Resistor, Film 1/8 W 5% 3.3 k Ω
R20	170115	Resistor, Trimmer 10 k Ω
R21	113224	Resistor, Film 1/8 W 5% 220 k Ω
R22	113103	Resistor, Film 1/8 W 5% 10 k Ω
R23	113181	Resistor, Film 1/8 W 5% 180 Ω
R24	124101	Resistor, Film 1/8 W 5% 100 Ω
R25	1111003	Resistor, Film 1/8 W 1% 100 k Ω
R26	1112003	Resistor, Film 1/8 W 1% 200 k Ω
R27	1114023	Resistor, Film 1/8 W 1% 402 k Ω
R28	113824	Resistor, Film 1/8 W 5% 820 k Ω
R29	113165	Resistor, Film 1/8 W 5% 1.6 M Ω
R30	113335	Resistor, Film 1/8 W 5% 3.3 M Ω
R31	1118252	Resistor, Film 1/8 W 1% 82.5 k Ω
R32	1112003	Resistor, Film 1/8 W 1% 200 k Ω
R33	1118252	Resistor, Film 1/8 W 1% 82.5 k Ω
R34,R35	113105	Resistor, Film 1/8 W 5% 1 M Ω
R36	113104	Resistor, Film 1/8 W 5% 100 k Ω
R37	113103	Resistor, Film 1/8 W 5% 10 k Ω
R38		Not Used.
R39	124020	Resistor, Film 1/4 W 5% 2.2 Ω
R40	170230	Resistor, Trimmer 10 k Ω

TABLE 6-2.
Parts List, Switch Module, M3B, Continued.

R41	1113012	Resistor, Film 1/4 W 1% 30.1 k Ω
R42	1111023	Resistor, Film 1/8 W 1% 102 k Ω
R43	113273	Resistor, Film 1/8 W 5% 27 k Ω
R44	113103	Resistor, Film 1/8 W 5% 10 k Ω
U1	330037	IC, CD4060BE
U2	330081	IC, LM358N
U3	330126	IC, CD4094BE/MC14094BCP
U4	330341	IC, RE5VA21AC
Y1	363001	Resonator, Ceramic 614.4 kHz

CHAPTER 7

TRANSMITTER MODULE, M4 - THEORY OF OPERATION

7-0 INTRODUCTION

The M4 module contains the transmit RF power amplifier and harmonic filters for the transceiver. The circuitry is mounted on PCB 738020 which is contained in a die-cast box mounted on the top front of the radio chassis (see Figure 1-3). Instructions for accessing and removing the module are given in Section 2-5.2.

7-1 MODULE INTERCONNECTIONS

The M4 module has the following interconnections with the rest of the radio:

Connector M4J1 (located on the right side of the module as mounted—see Figure 1-3):

- Pin 1 Medium-power control line from front-panel switch S3; +12 V when in "medium"-power position, open otherwise.
- Pin 2 High-power control line from front-panel switch S3; +12 V when in "high"-power position, open otherwise.
- Pin 3 TX +; +12 Vdc in transmit mode.
- Pin 4 Latch "1" line from M3J2-1; see section 6-1.
- Pin 5 Latch "0" line from M3J2-4; see section 6-1.
- Pin 6 T band 4 from M3J7-2; see section 6-1.
- Pin 7 T band 3 from M3J7-3; see section 6-1.
- Pin 8 T band 2 from M3J7-4; see section 6-1.
- Pin 9 T band 1 from M3J7-5; see section 6-1.
- Pin 10 Ground.

7-2 CIRCUIT DESCRIPTION

The drive to the transmitter is provided by the synthesizer module which operates on the transmitter output frequency and at an output level of +3 dBm. The modulator is in the synthesizer. Since the output spectrum has good spectral purity, the transmitter need only provide amplification to the desired output power level.

Transmitter Amplifier

The transmitter amplifier is a three-stage broadband amplifier covering the range 30-88 MHz with a power output of 3-5 W. Q1 is a high-gain, class A amplifier stabilized by the collector-base feedback through R7. The emitter bypass C2 is chosen to compensate for the fall in the gain at the high end of the range. The stage is LC

coupled to Q2, a second-class A amplifier using transformer coupling to the output stage. L21 provides a means of "peaking" the output at the high-frequency end of the range. Stage stabilization is provided by collector-base feedback through R10 and inductive feedback from a third winding on the output transformer coupled into the base through C4. The output stage, made up of Q3 and Q4, is configured as a class C push-pull amplifier driving a broadband output transformer. The push-pull scheme provides excellent suppression of even-ordered harmonics. The stage is stabilized by feed-forward compensation through C40 and C41 as well as collector-base feedback through C35, C36. C32 provides additional peaking at the high-frequency end. T2 is the output transformer and provides impedance matching to the amplifier.

Power Control

The transceiver has three different power-output levels. The power output is nominally—low power 300 mW, medium power 2 W, high power 3-5 W. The low power settings are used to reduce battery consumption in the transmit mode and to reduce the possibility of unwanted monitoring of the transmissions. The power levels are set by controlling the collector voltages to Q3 and Q4. In the high-power position the full battery voltage is applied to Q3 and Q4. In the medium-power position the supply voltage is dropped by R1 and R3 in parallel. In the low-power position R1 is switched out of circuit so that the supply voltage is dropped by R3. The power levels are controlled by the front-panel switch, S3, which is also used to switch the transceiver off.

Harmonic Filters

The transmitter has low spurious output, but the broadband final amplifier does require filtering to remove the harmonics of the output frequency. The frequency range is divided in four bands:

Band 1	30 to 39.975 MHz
Band 2	40 to 51.975 MHz
Band 3	52 to 67.975 MHz
Band 4	68 to 87.975 MHz

Separate 7-pole, low-pass Chebishev filters are used for each of the frequency bands. These filters are selected by the latching relays K1 to K8. Latching relays are used so that the only current drain is the momentary switching current when the frequency band is changed. The band selection is automatically controlled by the microprocessor and the drive circuitry is contained in the processor module. The two switching transistors Q5 and Q6 are used to select either the "open" or the "closed" coils on the latching relays. The latching information is provided by the microprocessor.

7-3 VOLTAGE CHARTS

Table 7-1 shows dc voltage levels at the pins of the M4 transmitter and IC's.

7-4 TEST AND ALIGNMENT

Module Test

The M4 module test is defined by TWC test procedure #991471. This procedure requires the use of a special test fixture and is not included in this manual.

Alignment

The harmonic filter coils should be aligned with power output, harmonic suppression and dc current drain in mind. The basic procedure for doing this is as follows:

A. Adjust L21 core to one turn above the top of the coil form. Adjust L4, L5, L8, L9, L12, L13, L16 and L17 so their cores are even with the top of the coil form. Adjust L3, L6, L7 and L10 so their cores are two turns off the bottom of the coil form. Remove the cores from L11, L14, L15 and L18.

B. Set the frequency to 87.975 MHz. Set the radio power switch to high. Turn the power switch on and key the radio with no modulation. Adjust C32 and L21 for maximum power output.

NOTE:

For HI power output the minimum allowable power output is 3.5 W, the maximum allowable current is 1.45 A and maximum allowable harmonics are -46 dB.

C. Adjust L16 and L17 until the power, current and harmonic specifications are made at 87.975 MHz. Now confirm that the power, current and harmonic specifications are made on 77.50 and 68.00 MHz. There should only be a very slight adjustment of L16 and L17 required.

D. Now repeat step C with each of the bands (see Table 7-2) until the power, current and harmonic specifications are made on all frequencies.

WARNING!

A slight increase in power coupled with a large increase in current draw may indicate the PA is oscillating.

E. Switch the power switch to the MEDIUM position. Check that the power output on all the frequencies is between 1.6 W and 2.8 W. The maximum allowable current is 1.0 A and the maximum allowable harmonics are -46 dB.

F. Switch the power switch to the LOW position. Check that the power output on all the frequencies is between 0.25 W and 0.55 W. The maximum allowable current is 0.7 A.

**TABLE 7-1.
M4 Dc Voltage Charts.**

<u>LOCATION</u>		<u>VOLTAGE</u>		<u>LOC.</u>	<u>VOLTAGE</u>	
<u>J1</u>	<u>PIN</u>	<u>RX</u>	<u>TX</u>	<u>Q1</u>	<u>RX</u>	<u>TX</u>
	1	—	13.40	C	—	11.3
	2	—	7.0	B	—	5.5
	3	—	13.40	E	—	4.9
	4	—	—			
	5	—	—	<u>Q2</u>	<u>RX</u>	<u>TX</u>
	6	—	—	C	—	13.5
	7	—	—	B	—	3.1
	8	—	—	E	—	—
	9	13.40	13.07			
	10	—	—			

<u>Q3</u>	<u>RX</u>	<u>TX</u>	<u>Q4</u>	<u>RX</u>	<u>TX</u>	<u>Q5</u>	<u>RX</u>	<u>TX</u>
C	—	13.35	C	—	13.3	C	—	—
B	—	13.28	B	—	13.3	B	—	—
E	—	—	E	—	—	E	—	—

<u>Q6</u>	<u>RX</u>	<u>TX</u>
C	—	—
B	—	—
E	—	—

**TABLE 7-2.
M4 Filter Adjustment Coils and Frequencies.**

<u>BAND</u>	<u>ADJUSTMENT COIL</u>	<u>FREQUENCY (MHz)</u>
1	L3,L4,L5,L6	30.000
1	L3,L4,L5,L6	34.500
1	L3,L4,L5,L6	39.975
2	L7,L8,L9,L10	40.000
2	L7,L8,L9,L10	45.500
2	L7,L8,L9,L10	51.975
3	L12,L13	52.000
3	L12,L13	59.500
3	L12,L13	67.975
4	L16,L17	68.000
4	L16,L17	77.500
4	L16,L17	87.975

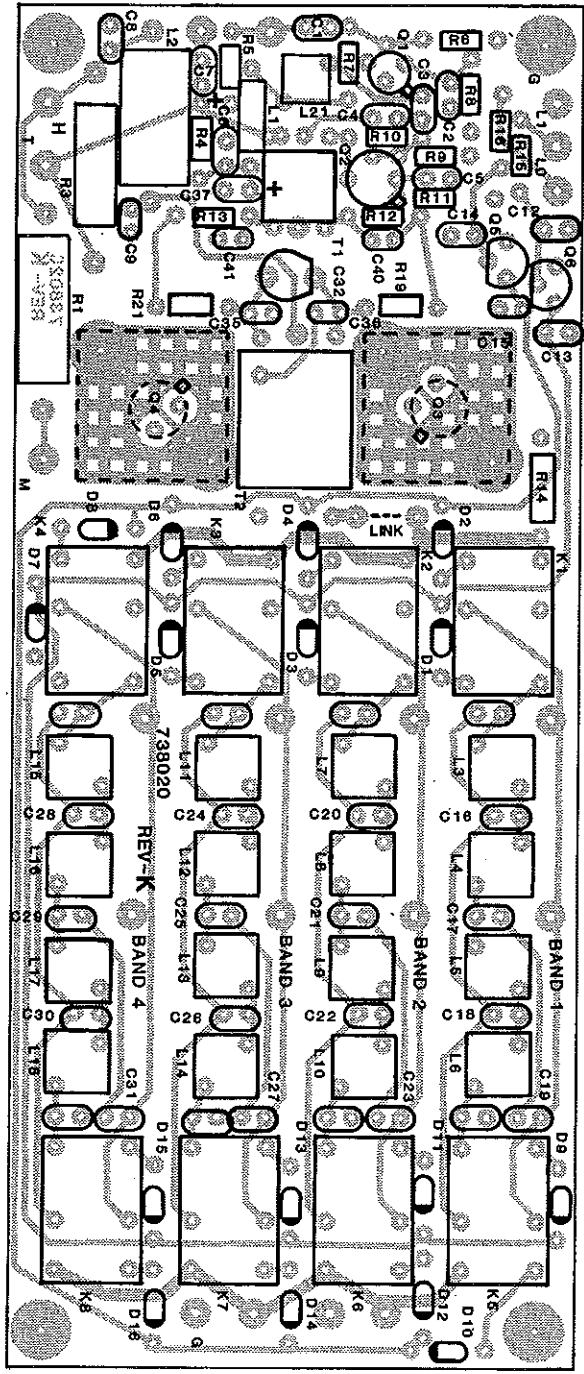
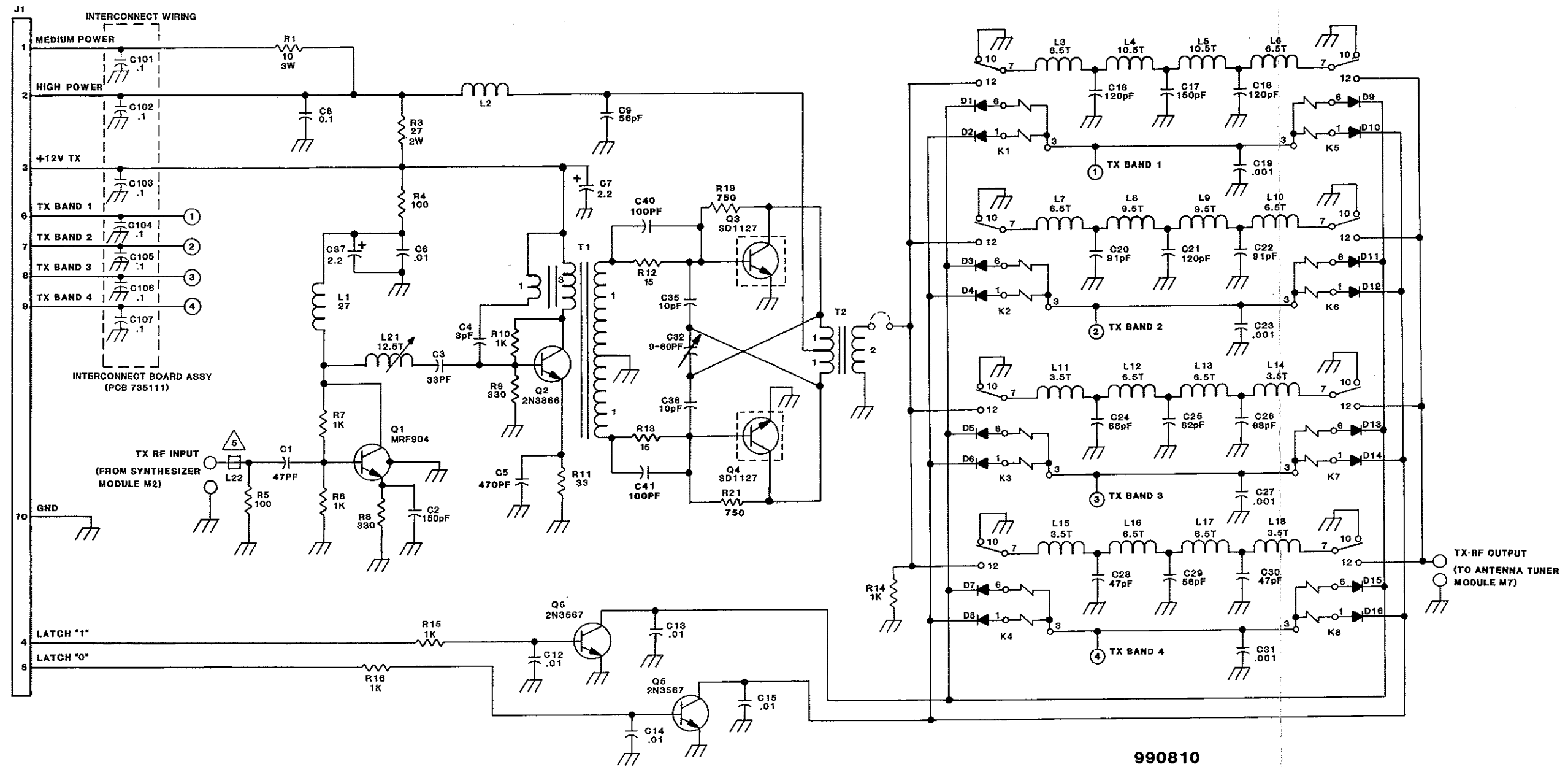

FIGURE 7-1.
Component Locations, Transmitter Module, M4.



990810

NOTES: (UNLESS OTHERWISE SPECIFIED)
 1. RESISTANCE IS IN OHMS.
 2. CAPACITANCE IS IN MICROFARADS.
 3. INDUCTANCE IS IN MICROHENRYS.
 4. DIODES ARE 1N4148.
 ▲ BEAD MUST BE LOCKED IN PLACE WITH RTV.

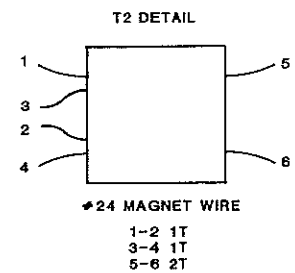
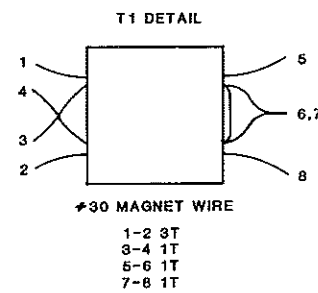

FIGURE 7-2. Schematic Diagram, Transmitter Module, M4.

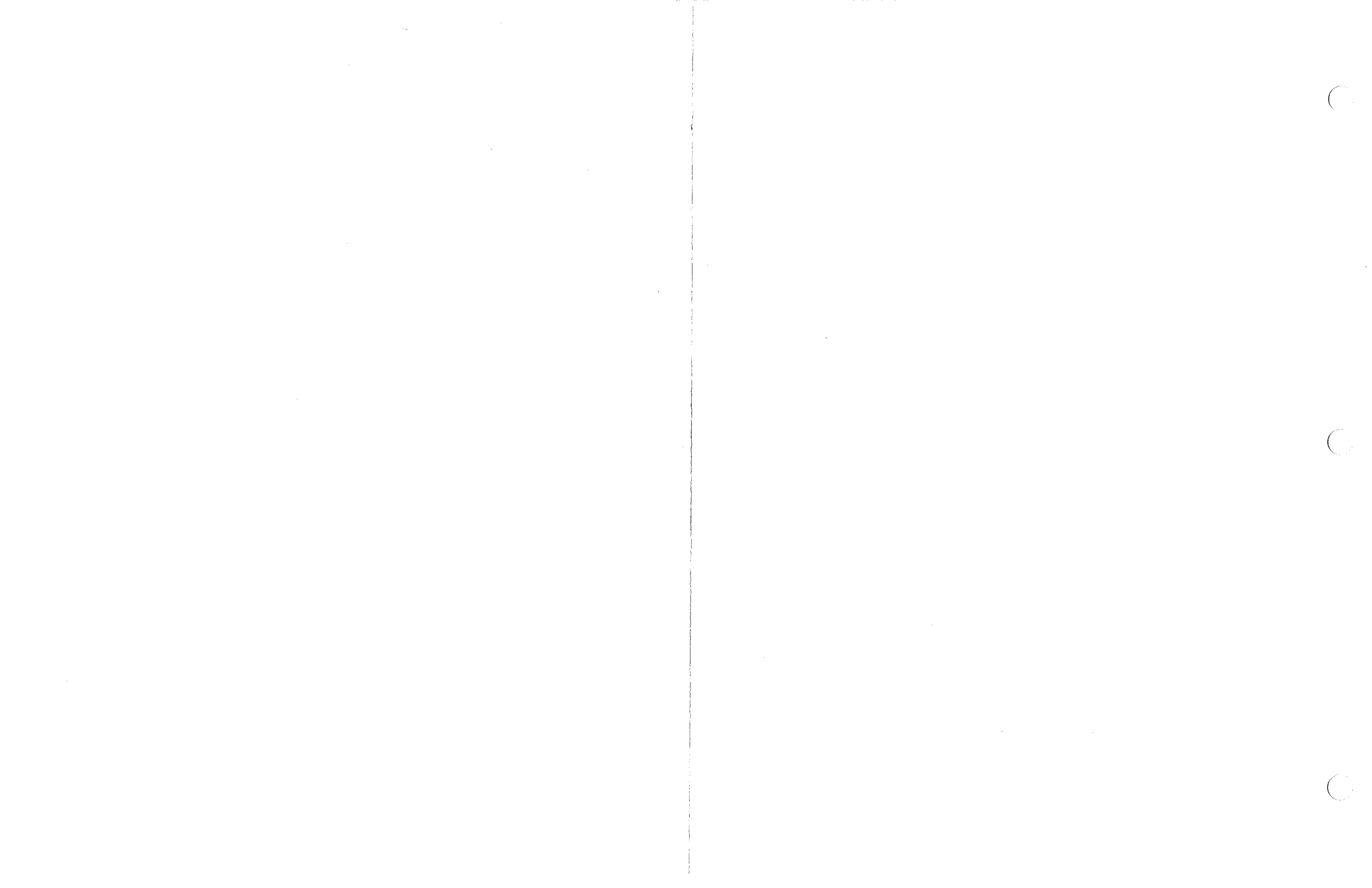

TABLE 7-3.
Parts List, Transmitter Module, M4.

C1	210470	Capacitor, Disc NPO 47 pF
C2	221151	Capacitor, Mica DM5 150 pF
C3	210330	Capacitor, Disc NPO 33 pF
C4	210030	Capacitor, Disc NPO 3 pF
C5	220471	Capacitor, Mica DM15 470 pF
C6	214103	Capacitor, Monolithic 50 V 0.01 μ F
C7	241020	Capacitor, Tantalum 2.2 μ F
C8	274104	Capacitor, Monolithic 50 V 0.1 μ F
C9	221560	Capacitor, Mica DM5 56 pF
C10, C11		Not Used.
C12-C15	214103	Capacitor, Monolithic 50 V 0.01 μ F
C16	221121	Capacitor, Mica DM5 120 pF
C17	221151	Capacitor, Mica DM5 150 pF
C18	221121	Capacitor, Mica DM5 120 pF
C19	210102	Capacitor, Disc .001 μ F
C20	221910	Capacitor, Mica DM5 91 pF
C21	221121	Capacitor, Mica DM5 120 pF
C22	221910	Capacitor, Mica DM5 91 pF
C23	210102	Capacitor, Disc .001 μ F
C24	221680	Capacitor, Mica DM5 68 pF
C25	221820	Capacitor, Mica DM5 82 pF
C26	221680	Capacitor, Mica DM5 68 pF
C27	210102	Capacitor, Disc .001 μ F
C28	221470	Capacitor, Mica DM5 47 pF
C29	221560	Capacitor, Mica DM5 56 pF
C30	221470	Capacitor, Mica DM5 47 pF
C31	210102	Capacitor, Disc .001 μ F
C32	261600	Capacitor, Trimmer 9-60 pF
C33,C34		Not Used.
C35,C36	210100	Capacitor, Disc NPO 10 pF
C37	241020	Capacitor, Tantalum 2.2 μ F
C38,C39		Not Used.
C40,C41	210101	Capacitor, Disc NPO 100 pF
C42-C100		Not Used.
C101-C107	275104	Capacitor, Monolithic 50 V 0.1 μ F
D1-D16	320002	Diode, 1N4148
K1-K8	540066	Relay, Latchseal
L1	430013	Inductor, Fixed 27 μ H
L2	490203	Inductor, Bead Ferrite
L3	490114	Inductor, Variable 6.5 turns
L4,L5	490134	Inductor, Variable 10.5 turns
L6,L7	490114	Inductor, Variable 6.5 turns
L8,L9	490132	Inductor, Variable 9.5 turns
L10	490114	Inductor, Variable 6.5 turns
L11	490135	Inductor, Variable 3.5 turns
L12,L13	490114	Inductor, Variable 6.5 turns
L14,L15	490135	Inductor, Variable 3.5 turns
L16,L17	490114	Inductor, Variable 6.5 turns
L18	490135	Inductor, Variable 3.5 turns
L19,L20		Not Used.
L21	490109	Inductor, Variable 12.5 turns
L22	490201	Inductor, Bead Ferrite

TABLE 7-3.
Parts List, Transmitter Module, M4, Continued.

Q1	310040	Transistor, NPN MRF904
Q2	310020	Transistor, NPN 2N3866
Q3,Q4	310028	Transistor, NPN SD1127
Q5,Q6	310003	Transistor, NPN 2N3567
R1	155100	Resistor, Film 3 W 5% 10 Ω
R2		Not Used.
R3	160270	Resistor, Wirewound 2 W 5% 27
R4,R5	113101	Resistor, Film 1/8 W 5% 100 Ω
R6,R7	113102	Resistor, Film 1/8 W 5% 1 k Ω
R8,R9	113331	Resistor, Film 1/8 W 5% 330 Ω
R10	113102	Resistor, Film 1/8 W 5% 1 k Ω
R11	124330	Resistor, Film 1/4 W 5% 33 Ω
R12,R13	113150	Resistor, Film 1/8 W 5% 15 Ω
R14	124102	Resistor, Film 1/4 W 5% 1 k Ω
R15,R16	113102	Resistor, Film 1/8 W 5% 1 k Ω
R17,R18		Not Used.
R19	124751	Resistor, Film 1/4 W 5% 750 Ω
R20		Not Used.
R21	124751	Resistor, Film 1/4 W 5% 750 Ω
T1	459154	Transformer, 3:1:2CT
T2	459140	Transformer, 2CT:2

CHAPTER 8

RECEIVER MODULE, M5 - THEORY OF OPERATION

8-0 INTRODUCTION

The M5 module contains the receiver circuitry for the transceiver. It is contained on PCB 738002 which is mounted in a die-cast box on the rear bottom of the chassis (see Figure 1-4). Instructions for accessing and removing the M5 module are given in Section 2-5.2.

8-1 MODULE INTERCONNECTIONS

The M5 module has the following interconnections with the radio.

Connector M5J1 (located at the end of the module—see Figure 1-4):

- Pin 1 +5 Vdc, regulated.
- Pin 2 RX +; +12 Vdc in receive mode.
- Pin 3 Noise squelch line to M1J2-5; see section 4-1.
- Pin 4 Tune voltage input from M3J7-12; see section 4-1.
- Pin 5 Receive audio output to M1J1-7; see section 4-1.
- Pin 6 R band 4 from M3J7-6; see section 6-1.
- Pin 7 R band 3 from M3J7-7; see section 6-1.
- Pin 8 R band 2 from M3J7-8; see section 6-1.
- Pin 9 R band 1 from M3J7-9; see section 6-1.
- Pin 10 Ground.

8-2 CIRCUIT DESCRIPTION

The receiver covers the frequency range 30-88 MHz in four bands:

Band 1	30 to 39.975 MHz
Band 2	42 to 51.975 MHz
Band 3	52 to 67.975 MHz
Band 4	68 to 87.975 MHz

The band information is decoded by the microprocessor, and one of the four band-select lines is energized. The band-select line provides the supply voltage to the RF stage and turns on the diode switches at the input and output tuned circuits.

RF Stages

There are separate RF stages for each of the four bands. This simplifies the bandswitching circuitry and provides optimum efficiency. The RF amplifiers Q1-Q4 are high-performance, bipolar transistors characterized by low intermodulation distortion and low noise figure at low operating currents. There are two tuned circuits at the input and two at the output. Inductive top coupling is used between the tuned circuits. Each inductor is resonated by a varactor diode (two diodes in parallel for band 1). The capacitance of the varactor diodes is varied by changing the tune voltage, which back biases the diodes. The

results are exactly the same as using a four-gang variable capacitor. The tune voltage is derived from a digital-to-analog converter in the processor. The tuning information is contained in digital form in memory and the microprocessor sends out the correct data stream to program the right tune voltage from the D-to-A converter. The trimmer R12 is used to set the tuning voltage range.

Mixer

The mixer stage Q5 is a dual-gate MOSFET which down converts to the first IF at 10.7 MHz. The signal is applied to gate 1 and the oscillator to gate 2. This gives good isolation between the two inputs and gives the dual-gate MOSFET good intermodulation characteristics.

Oscillator

The oscillator signal is supplied by the frequency synthesizer. High side injection is used for bands 1 and 2 and low side injection for bands 3 and 4. This means that the frequency synthesizer operates from 40.7 MHz to 77.3 MHz, which is a smaller tuning range than required in the transmit mode.

Filter & 10.7-MHz IF Stage

The main selectivity is immediately after the mixer, which gives maximum freedom from overload and spurious responses. The filter is a high-performance, eight-pole, monolithic crystal filter operating at a center frequency of 10.7 MHz. The filter is followed by a dual-gate MOSFET amplifier, Q6.

IF System

U1 is a complete low-power (6-V, 3-mA), narrow-band, FM IF system. The integrated circuit contains oscillator, mixer, limiting amplifier, quadrature discriminator, active filter, and squelch. The Colpitts oscillator is crystal controlled (Y1) and operates at 10.245 MHz. The 10.7-MHz input signal is down converted in the double-balanced mixer to the second IF at 455 kHz. The tuned circuit L28 provides IF filtering; the signal is then amplified and limited. L29 is the tuned circuit in the conventional quadrature FM detector. The system has excellent sensitivity and limits at 5 microvolts input.

The audio output at pin 9 goes to the audio module and to the internal operational amplifier configured as a high-pass filter. This amplifies the noise spectrum above the audio band. The external AM detector D29 checks for the presence of noise above the desired audio frequencies, and the output is applied to the squelch trigger circuit at pin 12. The trimmer R65 is used to set the bias at pin 12 so that the output at pin 13 is low. When pin 12 is pulled low by the detected noise at D29, the output of the squelch

trigger at pin 13 goes high and the switch Q7 provides low impedance return on the noise squelch line to the audio module.

The supply voltage is regulated to 7 V by an amplified zener (D30, Q8) used as a low-current-drain regulator.

8-3 VOLTAGE CHARTS

Table 8-1 shows the dc voltage levels on the M5 transistors and IC's.

8-4 TEST AND ALIGNMENT

Module Test

The M5 module test is defined by TWC test procedure #991472. This procedure requires the use of a special test fixture and is not included in this manual.

Alignment

Alignment of the receiver band coils is done for each of the four bands and is different depending on the grade of varactor (color code) used. The band test frequencies and tuning coils are given in Table 8-2. Using a signal generator and Sinadder, the module can be aligned in a radio if necessary as follows:

A. Set all M5 coil cores so that the top of the cores are even with the top of the coil form.

B. The pot R12 in the M5 should be set completely clockwise for version -203 or -204 software. For a non-

standard M5 with different color varactors (-202 software), check Table 8-3.

C. Adjust the frequency switch for 78.6 MHz. Change the signal generator to CH11. Put in 78.6 MHz at 6-kHz deviation. Increase the RF level until a tone is heard in the handset. Adjust volume for a comfortable listening level.

D. Now adjust coils L25, L26, L28, L29 and L31 to give the best sinad reading on the Sinadder. It will be necessary to lower the RF input level from the signal generator as these coils are aligned.

E. After the lowest sinad has been attained by adjusting L25, L26, L28, L29 and L31, adjust the coils associated with Band 4 (L19, L20, L21, L22) until the Sinadder reads -12 dB sinad or less at 0.30 microvolts (μV) input from the signal generator.

F. Check the sinad at the top and bottom of Band 4 to ensure that the -12 dB Sinad at 0.30 microvolts specification is maintained across the band. It may be necessary to make slight adjustments to the band coils to meet the specification.

G. Align the coils for bands 1, 2, and 3 in the same way band 4 was done. Perform the initial band alignments at the middle of each band and then check the top and bottom of the band. It should not be necessary to readjust coils L25, L26, L28, L29 and L31.

TABLE 8-1.
M5 Dc Voltage Levels.

<u>LOCATION</u>		<u>VOLTAGE</u>		<u>LOC.</u>	<u>VOLTAGE</u>		<u>LOC.</u>	<u>VOLTAGE</u>	
<u>J1</u>	<u>PIN</u>	<u>RX</u>	<u>TX</u>	<u>Q1</u>	<u>RX</u>	<u>TX</u>	<u>Q2-Q4</u>		
	1	4.90	4.90	C	9.1	8.1	Same as Q1 when selected.		
	2	13.50	13.50	B	0.7	0.6			
	3	—	—	E	—	—			
	4	1.90	1.90						
	5	4.07	3.60	<u>Q5</u>	<u>RX</u>	<u>TX</u>	<u>Q6</u>	<u>RX</u>	<u>TX</u>
	6	—	—	S	4.6	4.3	S	1.2	1.2
	7	—	—	G1	3.8	3.8	G1	—	—
	8	—	—	G2	3.8	3.6	G2	5.0	4.8
	9	13.48	13.05	D	11.3	11.1	D	—	—
	10	—	—						

**TABLE 8-1.
M5 Dc Voltage Levels, Continued.**

<u>LOCATION</u>		<u>VOLTAGE</u>		<u>LOC.</u>	<u>VOLTAGE</u>		<u>LOC.</u>	<u>VOLTAGE</u>	
<u>U1</u>	<u>PIN</u>	<u>RX</u>	<u>TX</u>	<u>PIN</u>	<u>RX</u>	<u>TX</u>	<u>Q7</u>	<u>RX</u>	<u>TX</u>
	1	7.4	7.4	9	3.8	3.8	C	—	—
	2	6.8	6.8	10	2.0	2.0	B	0.6	0.6
	3	7.4	7.4	11	2.1	2.1	E	—	—
	4	7.4	7.4	12	0.5	0.7			
	5	1.0	1.0	13	6.8	—	<u>Q8</u>	<u>RX</u>	<u>TX</u>
	6	1.0	1.0	14	—	0.3	C	11.00	10.50
	7	1.0	1.0	15	—	—	B	8.14	8.14
	8	7.4	7.4	16	2.0	2.0	E	7.40	7.40

**TABLE 8-2.
M5 Frequency Bands.**

<u>BAND</u>	<u>COILS</u>	<u>BOTTOM (MHz)</u>	<u>MIDDLE (MHz)</u>	<u>TOP (MHz)</u>
1	L1, L2, L3, L4	30.600 (CH01)	34.600 (CH02)	39.600 (CH03)
2	L7, L8, L9, L10	40.600 (CH04)	46.600 (CH05)	51.600 (CH06)
3	L13, L14, L15, L16	52.600 (CH07)	59.600 (CH08)	67.600 (CH09)
4	L19, L20, L21, L22	68.600 (CH10)	78.600 (CH11)	87.600 (CH12)

NOTE

When changing the test-fixture frequency, the signal generator must also be changed to the channel shown in parentheses.

**TABLE 8-3.
-202 Software Varactor Settings.**

<u>VARACTOR COLOR</u>	<u>R12 SETTING (O'CLOCK POSITION)</u>
Violet	4
Green	2
Brown	2
Red	12
Grey	11
Blue	10
Yellow	9
White	8

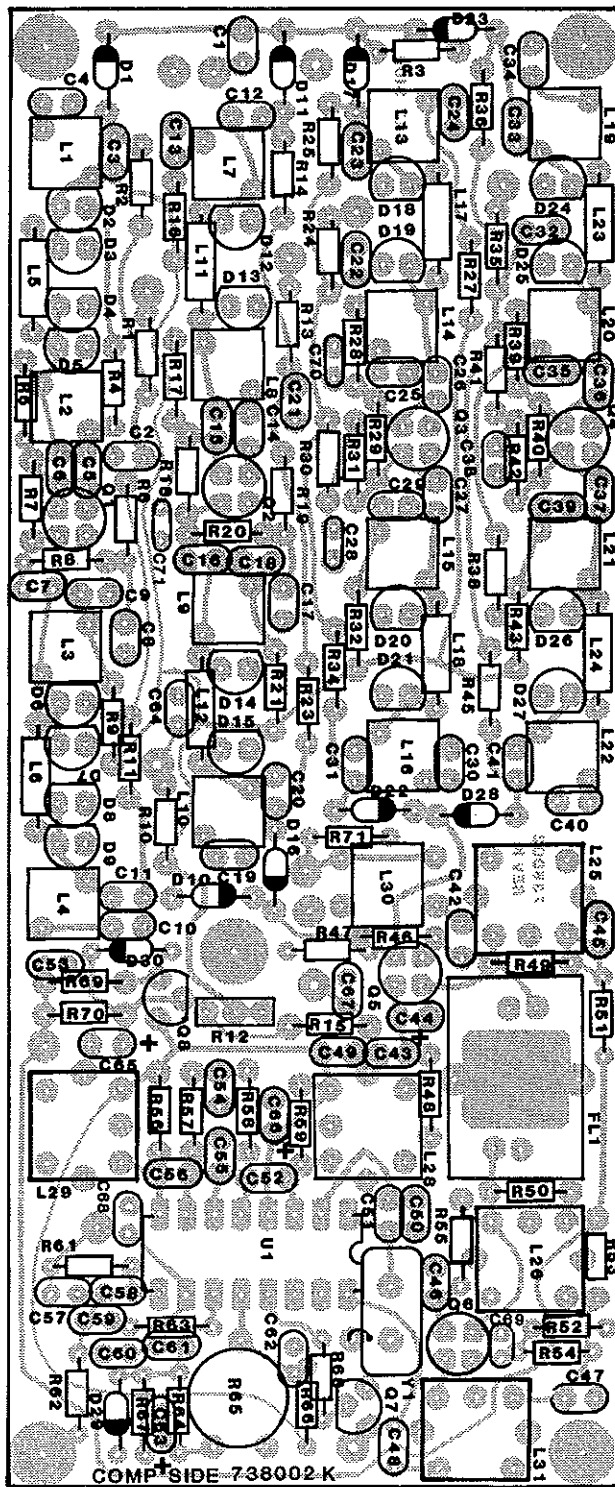

FIGURE 8-1.
Component Locations, Receiver Module, M5.

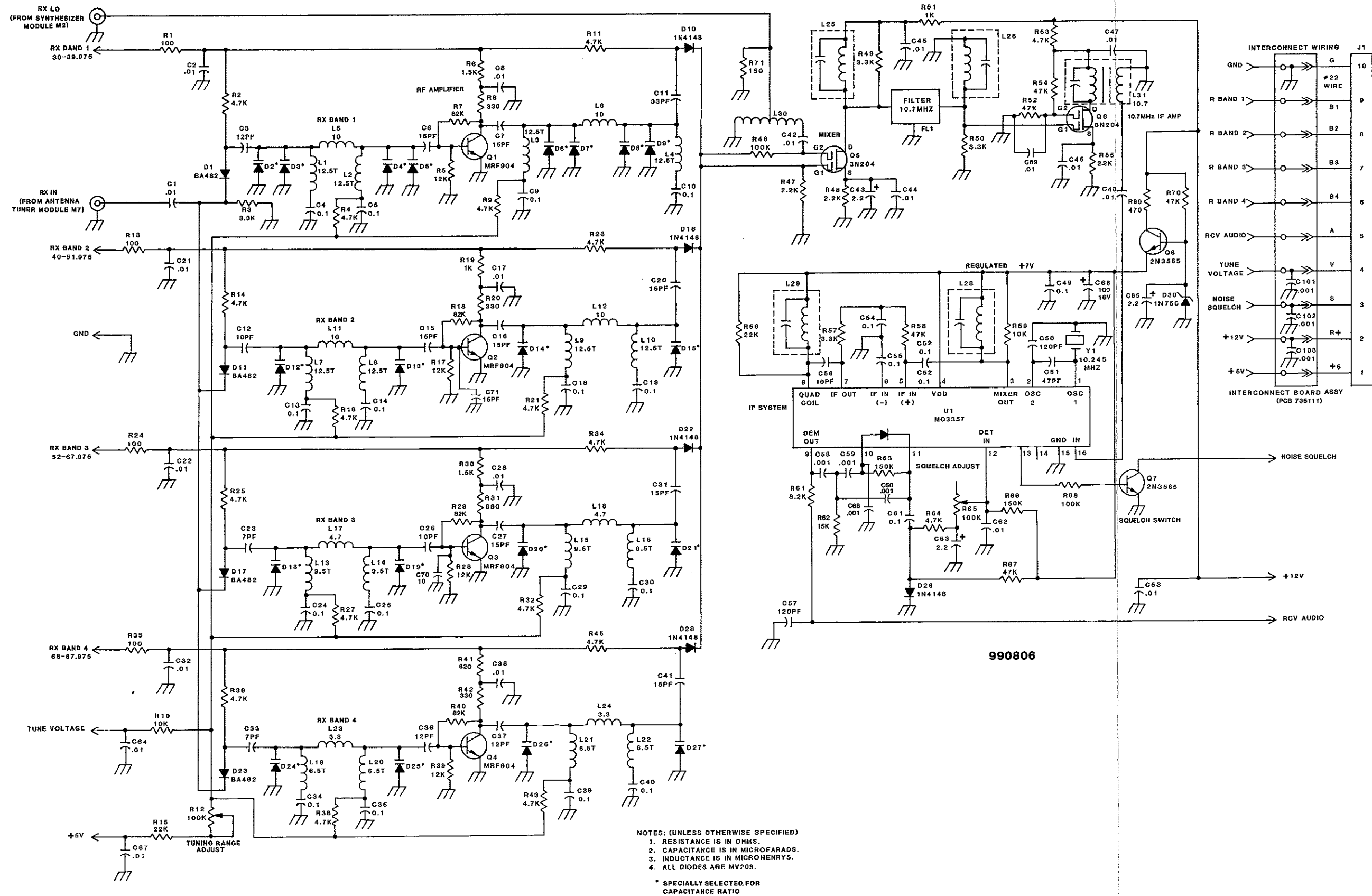

FIGURE 8-2. Schematic Diagram, Receiver Module, M5.

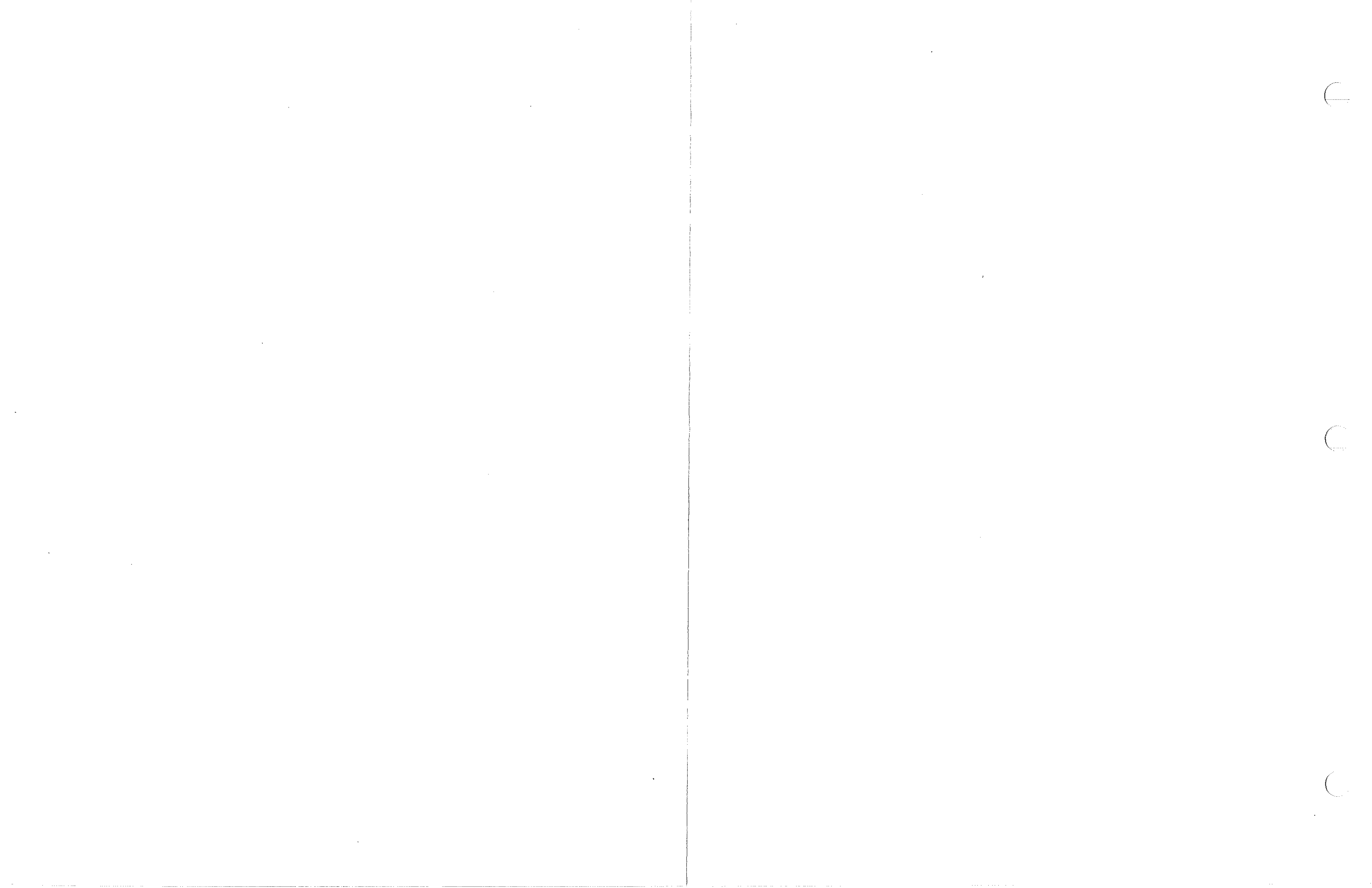

TABLE 8-4.
Parts List, Receiver Module, M5.

C1,C2	214103	Capacitor, Monolithic 50 V 0.01 μ F
C3	210120	Capacitor, Disc NPO 12 pF
C4,C5	275104	Capacitor, Monolithic 50 V 0.1 μ F
C6,C7	210150	Capacitor, Disc NPO 15 pF
C8	214103	Capacitor, Monolithic 50 V 0.01 μ F
C9,C10	275104	Capacitor, Monolithic 50 V 0.1 μ F
C11	210330	Capacitor, Disc NPO 33 pF
C12	210100	Capacitor, Disc NPO 10 pF
C13,C14	275104	Capacitor, Monolithic 50 V 0.1 μ F
C15,C16	210150	Capacitor, Disc NPO 15 pF
C17	214103	Capacitor, Monolithic 50 V 0.01 μ F
C18,C19	275104	Capacitor, Monolithic 50 V 0.1 μ F
C20	210150	Capacitor, Disc NPO 15 pF
C21,C22	214103	Capacitor, Monolithic 50 V 0.01 μ F
C23	210070	Capacitor, Disc NPO 7 pF
C24,C25	275104	Capacitor, Monolithic 50 V 0.1 μ F
C26	210100	Capacitor, Disc NPO 10 pF
C27	210150	Capacitor, Disc NPO 15 pF
C28	214103	Capacitor, Monolithic 50 V 0.01 μ F
C29,C30	275104	Capacitor, Monolithic 50 V 0.1 μ F
C31	210150	Capacitor, Disc NPO 15 pF
C32	214103	Capacitor, Monolithic 50 V 0.01 μ F
C33	210070	Capacitor, Disc NPO 7 pF
C34,C35	275104	Capacitor, Monolithic 50 V 0.1 μ F
C36,C37	210120	Capacitor, Disc NPO 12 pF
C38	214103	Capacitor, Monolithic 50 V 0.01 μ F
C39,C40	275104	Capacitor, Monolithic 50 V 0.1 μ F
C41	210150	Capacitor, Disc NPO 15 pF
C42	214103	Capacitor, Monolithic 50 V 0.01 μ F
C43	241020	Capacitor, Tantalum 2.2 μ F
C44-C48	214103	Capacitor, Monolithic 50 V 0.01 μ F
C49	275104	Capacitor, Monolithic 50 V 0.1 μ F
C50	221121	Capacitor, Mica DM5 120 pF
C51	221470	Capacitor, Mica DM5 47 pF
C52-C55	275104	Capacitor, Monolithic 50 V 0.1 μ F
C56	210100	Capacitor, Disc NPO 10 pF
C57	210121	Capacitor, Disc NPO 120 pF
C58-C60	210102	Capacitor, Disc 0.001 μ F
C61	275104	Capacitor, Monolithic 50 V 0.1 μ F
C62	214103	Capacitor, Monolithic 50 V 0.01 μ F
C63	241020	Capacitor, Tantalum 2.2 μ F
C64	214103	Capacitor, Monolithic 50 V 0.01 μ F
C65	241020	Capacitor, Tantalum 2.2 μ F
C66	231101	Capacitor, Electrolytic 16 V 100 μ F
C67	214103	Capacitor, Monolithic 50 V 0.01 μ F
C68	210102	Capacitor, Disc 0.001 μ F
C69	214103	Capacitor, Monolithic 50 V 0.01 μ F
C70	210100	Capacitor, Disc NPO 10 pF
C71	210150	Capacitor, Disc NPO 15 pF
C72-C100		Not Used.
C101-C103	210102	Capacitor, Disc 0.001 μ F
D1	320005	Diode, PIN BA482
D2-D9	320305B	Diode, MV209
D10	320002	Diode, 1N4148
D11	320005	Diode, PIN BA482

TABLE 8-4.
Parts List, Receiver Module, M5, Continued.

D12-D15	320305B	Diode, MV209
D16	320002	Diode, 1N4148
D17	320005	Diode, PIN BA482
D18-D21	320305B	Diode, MV209
D22	320002	Diode, 1N4148
D23	320005	Diode, PIN BA482
D24-D27	320305B	Diode, MV209
D28,D29	320002	Diode, 1N4148
D30	320202	Diode, Zener 1N756
FL1	370008	Filter, Crystal 8P 10.7 MHz
L1-L4	490137	Inductor, Variable 12.5 turns
L5,L6	430029	Inductor, Fixed 10 μ H
L7-L10	490137	Inductor, Variable 12.5 turns
L11,L12	430029	Inductor, Fixed 10 μ H
L13-L16	490132	Inductor, Variable 9.5 turns
L17,L18	430028	Inductor, Fixed 4.7 μ H
L19-L22	490133	Inductor, Variable 6.5 turns
L23,L24	430027	Inductor, Fixed 3.3 μ H
L25,L26	420017	Inductor, IF 10.7 MHz
L27		Not Used.
L28,L29	420020	Inductor, IF 455 kHz
L30	459155	Inductor, Variable 1:2 turns
L31	420017	Inductor, IF 10.7 MHz
Q1-Q4	310040	Transistor, NPN MRF904
Q5,Q6	310001	Transistor, MFT 3N204
Q7,Q8	310006	Transistor, NPN 2N3565
R1	113101	Resistor, Film 1/8 W 5% 100 Ω
R2	113472	Resistor, Film 1/8 W 5% 4.7 k Ω
R3	113332	Resistor, Film 1/8 W 5% 3.3 k Ω
R4	113472	Resistor, Film 1/8 W 5% 4.7 k Ω
R5	113123	Resistor, Film 1/8 W 5% 12 k Ω
R6	113152	Resistor, Film 1/8 W 5% 1.5 k Ω
R7	113823	Resistor, Film 1/8 W 5% 82 k Ω
R8	113331	Resistor, Film 1/8 W 5% 330 Ω
R9	113472	Resistor, Film 1/8 W 5% 4.7 k Ω
R10	113103	Resistor, Film 1/8 W 5% 10 k Ω
R11	113472	Resistor, Film 1/8 W 5% 4.7 k Ω
R12	170215	Resistor, Potentiometer 100 k Ω
R13	113101	Resistor, Film 1/8 W 5% 100 Ω
R14	113472	Resistor, Film 1/8 W 5% 4.7 k Ω
R15	113223	Resistor, Film 1/8 W 5% 22 k Ω
R16	113472	Resistor, Film 1/8 W 5% 4.7 k Ω
R17	113123	Resistor, Film 1/8 W 5% 12 k Ω
R18	113823	Resistor, Film 1/8 W 5% 82 k Ω
R19	113102	Resistor, Film 1/8 W 5% 1 k Ω
R20	113331	Resistor, Film 1/8 W 5% 330 Ω
R21	113472	Resistor, Film 1/8 W 5% 4.7 k Ω
R22		Not Used.
R23	113472	Resistor, Film 1/8 W 5% 4.7 k Ω
R24	113101	Resistor, Film 1/8 W 5% 100 Ω
R25	113472	Resistor, Film 1/8 W 5% 4.7 k Ω
R26		Not Used.

TABLE 8-4.
Parts List, Receiver Module, M5, Continued.

R27	113472	Resistor, Film 1/8 W 5% 4.7 k Ω
R28	113123	Resistor, Film 1/8 W 5% 12 k Ω
R29	113823	Resistor, Film 1/8 W 5% 82 k Ω
R30	113152	Resistor, Film 1/8 W 5% 1.5 k Ω
R31	113681	Resistor, Film 1/8 W 5% 680 Ω
R32	113472	Resistor, Film 1/8 W 5% 4.7 k Ω
R33		Not Used.
R34	113472	Resistor, Film 1/8 W 5% 4.7 k Ω
R35	113101	Resistor, Film 1/8 W 5% 100 Ω
R36	113472	Resistor, Film 1/8 W 5% 4.7 k Ω
R37		Not Used.
R38	113472	Resistor, Film 1/8 W 5% 4.7 k Ω
R39	113123	Resistor, Film 1/8 W 5% 12 k Ω
R40	113823	Resistor, Film 1/8 W 5% 82 k Ω
R41	113821	Resistor, Film 1/8 W 5% 820 Ω
R42	113331	Resistor, Film 1/8 W 5% 330 Ω
R43	113472	Resistor, Film 1/8 W 5% 4.7 k Ω
R44		Not Used.
R45	113472	Resistor, Film 1/8 W 5% 4.7 k Ω
R46	113104	Resistor, Film 1/8 W 5% 100 k Ω
R47,R48	113222	Resistor, Film 1/8 W 5% 2.2 k Ω
R49,R50	113332	Resistor, Film 1/8 W 5% 3.3 k Ω
R51	113102	Resistor, Film 1/8 W 5% 1 k Ω
R52	113473	Resistor, Film 1/8 W 5% 47 k Ω
R53	113472	Resistor, Film 1/8 W 5% 4.7 k Ω
R54	113473	Resistor, Film 1/8 W 5% 47 k Ω
R55	113222	Resistor, Film 1/8 W 5% 2.2 k Ω
R56	113223	Resistor, Film 1/8 W 5% 22 k Ω
R57	113332	Resistor, Film 1/8 W 5% 3.3 k Ω
R58	113473	Resistor, Film 1/8 W 5% 47 k Ω
R59	113103	Resistor, Film 1/8 W 5% 10 k Ω
R60		Not Used.
R61	113822	Resistor, Film 1/8 W 5% 8.2 k Ω
R62	113153	Resistor, Film 1/8 W 5% 15 k Ω
R63	113154	Resistor, Film 1/8 W 5% 150 k Ω
R64	113472	Resistor, Film 1/8 W 5% 4.7 k Ω
R65	170115	Resistor, Trimmer 100 k Ω
R66	113154	Resistor, Film 1/8 W 5% 150 k Ω
R67	113473	Resistor, Film 1/8 W 5% 47 k Ω
R68	113104	Resistor, Film 1/8 W 5% 100 k Ω
R69	113471	Resistor, Film 1/8 W 5% 470 Ω
R70	113473	Resistor, Film 1/8 W 5% 47 k Ω
R71	113151	Resistor, Film 1/8 W 5% 150 Ω
U1	330147	IC, MC3357P
Y1	360010	Crystal 10.245 MHz

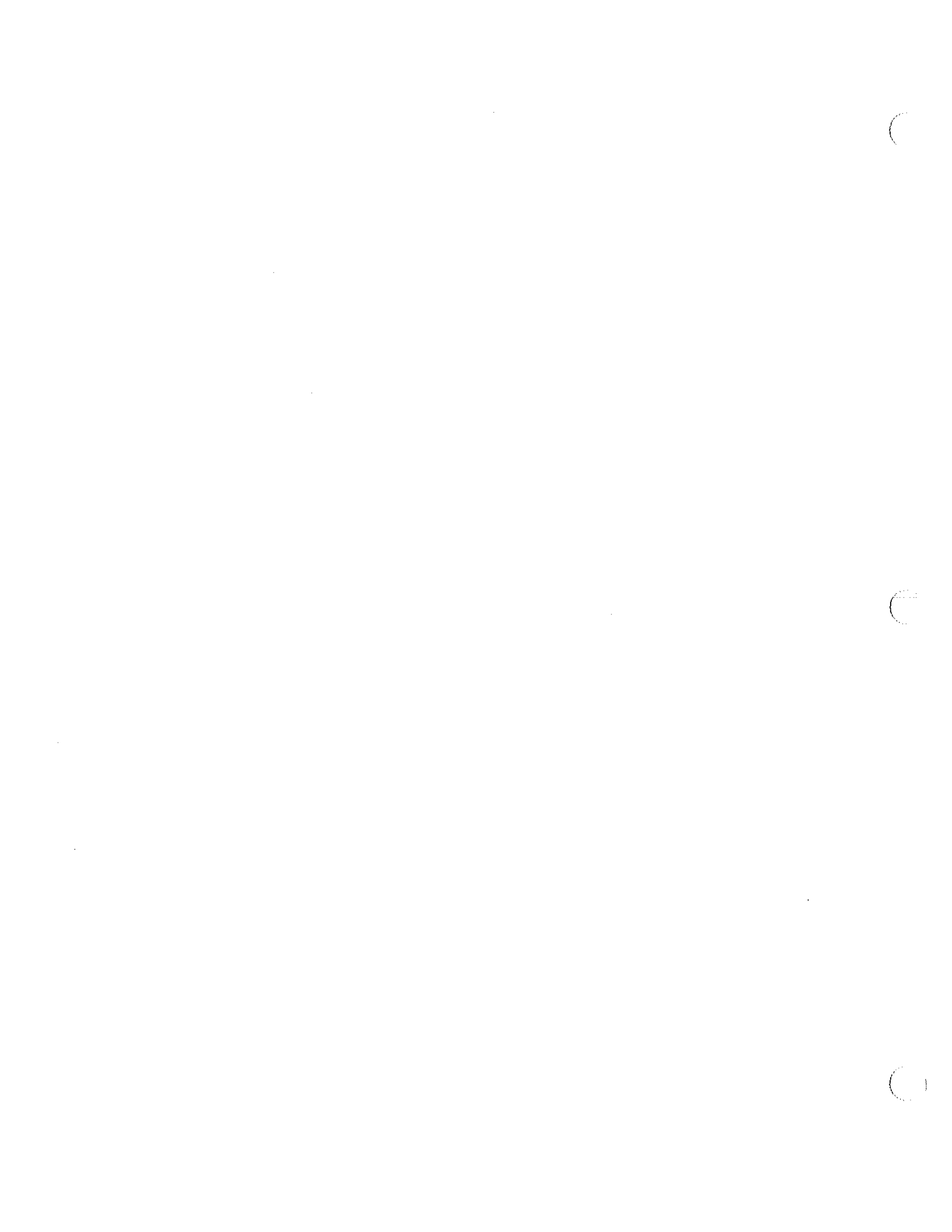

CHAPTER 9

DISPLAY BOARD MODULE, M6 - THEORY OF OPERATION

9-0 GENERAL

The LCD (Liquid Crystal Display) is attached to the M6 PCB. This module also contains the display-driver integrated circuit, backplane signal generator, backlight generator, backlight timer circuit, and low-battery alarm-tone generator. The 5 V for these circuits is supplied by the regulator in the processor module. The circuitry is contained on PCB 738173 which is mounted to the front panel (see Figure 1-4). Instructions for access and removal are given in Section 2-5.2.

The display driver is a CMOS, low-current device. It is a 32-bit, serial-in, parallel-out shift register, which has the ability to have the output complimented (inverted) under control of an external signal.

9-1 MODULE INTERCONNECTIONS

The M6 module is connected to the rest of the transceiver as follows:

Connector M6J1 (see Figure 1-3 for location):

- Pin 1 Ground.
- Pin 2 Data line from M3J1-3; see section 6-1.
- Pin 3 Display clock from M3J1-2; see section 6-1.
- Pin 4 +5 Vdc, regulated.
- Pin 5 No connection.

Connector M6J2 (see Figure 1-3 for location).

- Pin 1 From the "LITE" position on the front-panel switch S1A; normally open, grounded when S1A is in the "LITE" position.
- Pin 2 +12 Vdc, switched.
- Pin 3 From the front-panel MHz and kHz switches; normally open, grounded when either switch pressed.
- Pin 4 Noise squelch from M1J2-5; see section 4-1.
- Pin 5 Top side of volume pot from M1J1-5; see section 4-1.

Connector M6J3 (Extended Control Option).

- Pin 1 Digit D0 Control.
- Pin 2 Digit D1 Control.
- Pin 3 Digit D2 Control.
- Pin 4 Digit D3 Control.
- Pin 5 Extended control channel change signal.
- Pin 6 Reserved for option.
- Pin 7 Reserved for option.
- Pin 8 Reserved for option.
- Pin 9 Reserved for option.
- Pin 10 Reserved for option.

9-2 CIRCUIT DESCRIPTION

The supply voltage is 5 V and the LCD supply current is exceptionally low (approximately 2 microamps). The data and clock line provide for the serial inputting of data to the

drivers. A total of 32 serial bits must be shifted each time the display is updated.

The LCD requires a backplane signal to operate correctly. The signal must be a good square wave. This signal is generated internally in U1. The backplane drive frequency is 100 Hz. To drive an LCD, it is necessary to apply both the backplane signal and the inverted signal to the desired segment. The segments that are off are driven by the non-inverted backplane signal. Each output bit which is a zero (0) will follow the backplane signal, and the ones (1) will be inverted so the desired segment is turned on. By shifting in the right combination of data, the right segments will be turned on to display the correct frequency.

The LCD is back lit by an electroluminescent display on the backplane. The power supply is turned on when the mode switch is in the "lite" position, or when either of the front-panel frequency-tuning controls are operated. When the front-panel "mode" switch is in the "lite" position, the emitter of Q1 is grounded, which drives the step-up auto transformer T1. When either of the frequency-tuning controls are operated, pin J2-3 is grounded, which causes C8 to be discharged via diode CR3. The Schmitt "Nand" gate, U4B, (CD4093) is configured as a monostable multivibrator whose output, pin 4, is high for the period that its input, pin 6, is low.

With U4B, pin 4 output high, transistor Q3 conducts, which grounds the emitter of Q1, and drives the autotransformer T1. When the ground on J2-3 is removed, U4B, pin 6 begins to rise due to the RC time constant R15, C8. When U4B, pin 6 reaches approximately 2.5 V, U4B, pin 4, will go low, which turns Q3 off and extinguishes the display backlight. Diode CR4 provides an output, J2-4, to the noise-squelch input in module M1, (J2-5). The output will squelch the radio only during the time that the frequency-tuning knobs are operated.

The low-battery alarm circuitry consists of U3, U4C, D, Q2 and Q4. The actual voltage detector is integrated circuit U3. The voltage-detector output (open drain type), U3 pin 3, is low when the input voltage to U3, pin 2 is below 2.1 volts. The input voltage is derived from the +12-V battery voltage by resistors R11 and R13. These resistors have been chosen to provide a detector switch point at a battery voltage of 10.5 V. The tone-generating circuit consists of U4D that is configured as an astable multivibrator having an asymmetrical output. The asymmetrical nature of this output is determined by C6, R5 and R6. The "ON" portion of the output cycle (U4D, pin 11 = 5 V) is determined by the RC time constant R6, C6. The "OFF" portion of the output cycle (U4D, pin 11 = 0 V) is determined by RC time constant R5, C6. If the voltage detector (U3,

pin 2) senses a voltage greater than 2.1 V, its output (U3, pin 1) will be a high impedance which allows Q2 to conduct and clamps U4C, pin 8 to approximately 0 V. This clamping action inhibits U4C (an \approx 800-Hz astable multivibrator) from running. If however the voltage at U3, pin 2 falls below 2.1 V, U3, pin 1 will become a low impedance to ground, which causes Q2 to cease conducting. This allows U4C, pin 8 to follow the output of U4D, pin 11, which enables the 800-Hz multivibrator whenever U4D, pin 11 is high. Gate U4C injects the tone onto the top of the volume-control potentiometer via connector J2-5.

The standard configuration will allow the low-battery alarm to be heard in all "Mode-Switch" positions due to transistor Q4 which conducts whenever the "low-battery alarm" is activated. Whenever Q4 conducts, Pin M6-J2-7 will go low and the radio is then forced into the "RX-Test" mode, overriding the effect of the "Mode Switch."

Should this facility not be desired, the removal and sleeving of the wire in connector M6-J2-7 will prevent the "low-battery alarm" from being heard, unless the radio is in the "RX-Test" position, or squelch is broken.

9-3 EXTENDED CONTROL OPTION - GENERAL DESCRIPTION

The PRC1077-ECO Extended Control Option allows the operator to remotely control radio functions from either a specially equipped handset or the PRC1077-ECU (Extended Control Unit). The connector wiring for this option is specified at the time of order.

The remote control handset functions include:

- Channel change.
- Volume adjust.
- Local control.*

* For local control put the handset channel selector in "C" or "I/C."

The PRC1077 Extended Control Unit (PRC1077-ECU) functions include:

- Channel change.
- Volume adjust/external speaker driving capability.
- PTT inhibit function.
- Speaker ON/OFF select.
- Squelch override function.
- Remote radio power ON/OFF.

The circuit description for the remote channel change function is described in the following section.

9-4 CIRCUIT DESCRIPTION

Refer to Figure 9-2, page 9-5 for a schematic diagram of the circuit. Channel changes from the extended control handset or unit are decoded by U6 and U7. The channels are switched by means of a resistive divider running off of 8.0 Vdc. The top leg of the divider is R30 on the M6. The bottom legs are in the remote handset and are selected by the handset channel knob. Each of the bottom legs applies a different voltage to the U6-pin 5 input. Inside U6, this voltage is compared to a reference voltage which is run down a 10-step voltage divider. Each step has its own comparator which is turned on (output low) when the channel voltage is within that comparator window. The reference voltages are derived from the 12.0-Vdc line, by reference voltage source U2 and U5.

Resistor pack RP1 is used as pull-ups for the open-collector outputs of U4. These outputs are fed to U7, a CMOS decimal-to-BCD decoder. The four BCD outputs are connected to the channel-select lines of the microprocessor via four isolation diodes.

This page intentionally left blank.

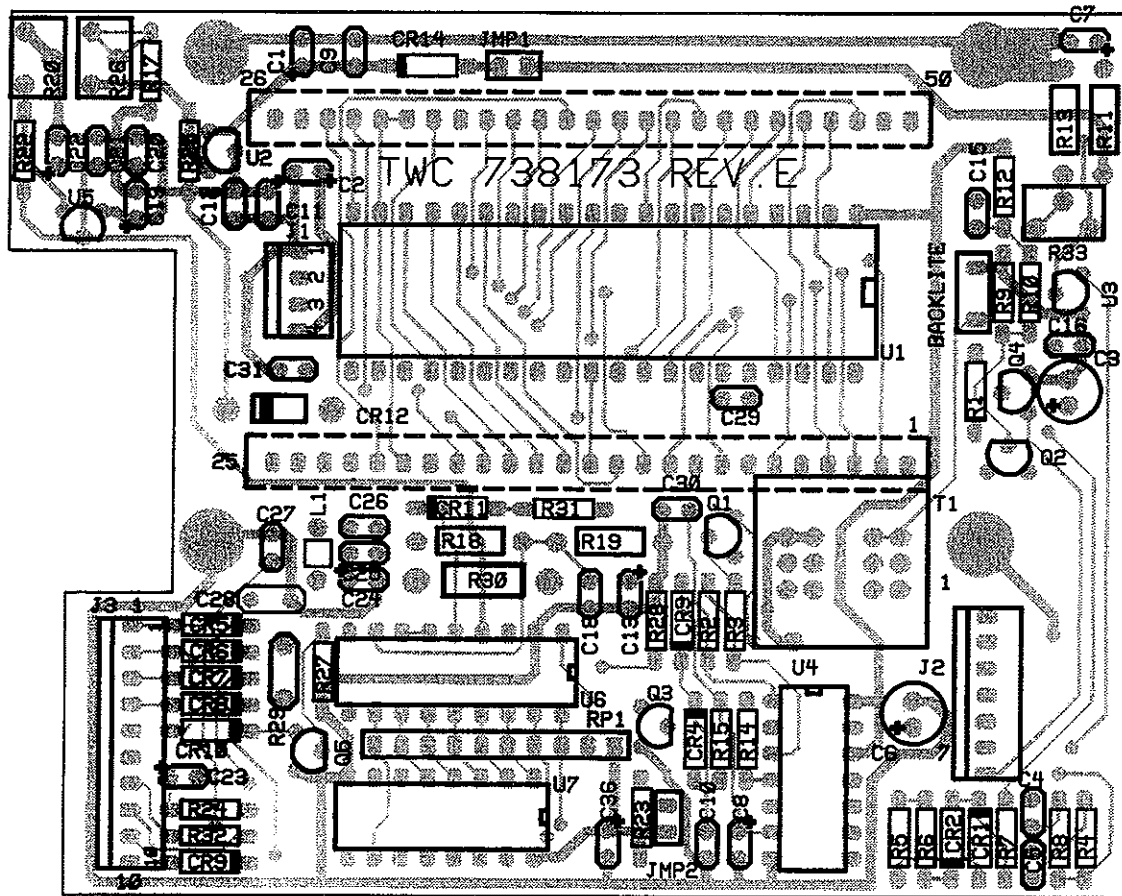

FIGURE 9-1.
Component Locations, Display Module, M6.

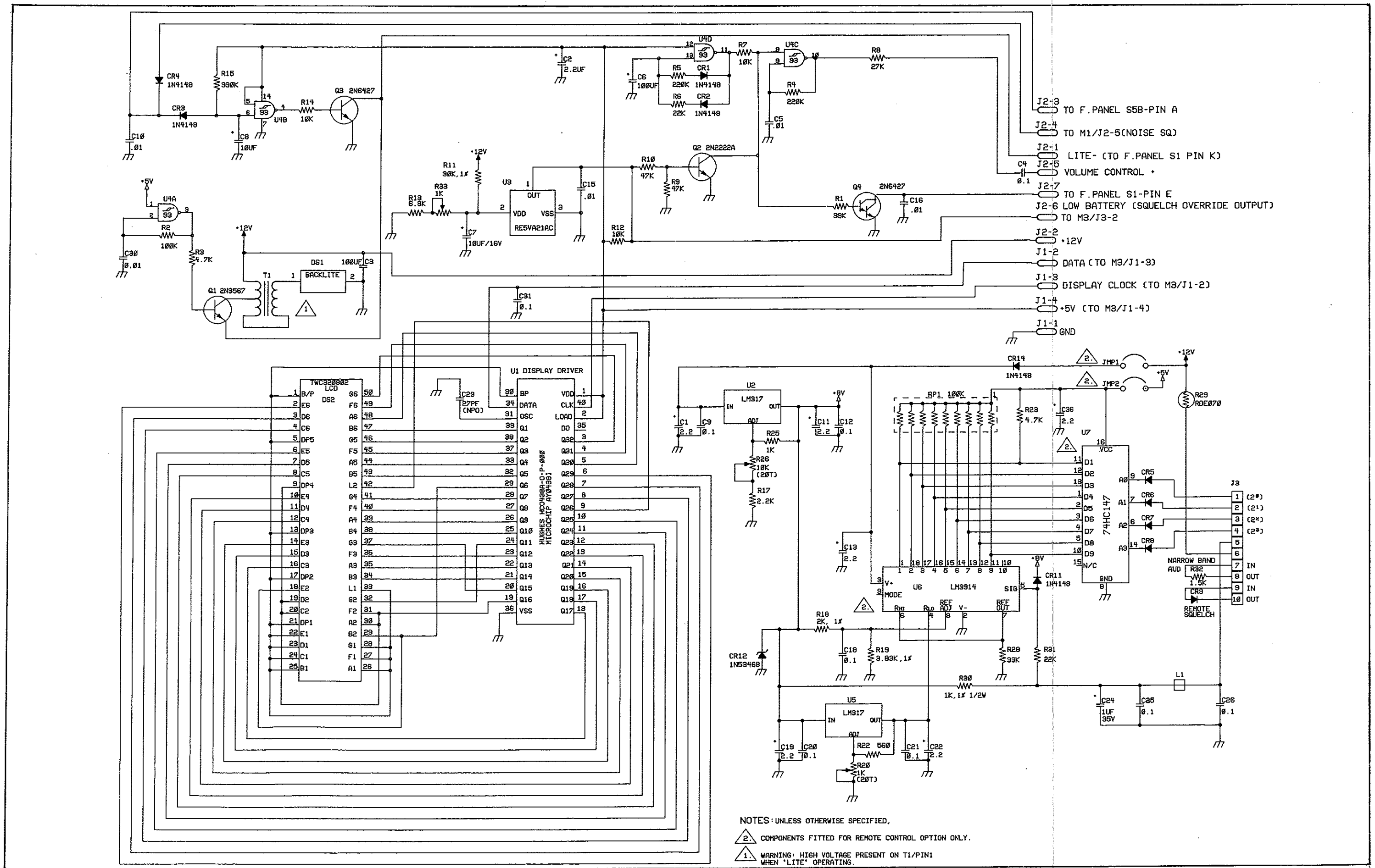

FIGURE 9-2. Schematic Diagram, Display Board Module, M6.



TABLE 9-1.
Parts List, Display Board Module, M6.

C1,C2	241020	Capacitor, Tantalum 2.2 μ F
C3	237101	Capacitor, Electrolytic 16 V 100 μ F
C4	275104	Capacitor, Monolithic 50 V 0.1 μ F
C5	214103	Capacitor, Monolithic 50 V 0.01 μ F
C6	237101	Capacitor, Electrolytic 16 V 100 μ F
C7	237100	Capacitor, Electrolytic 16 V 10 μ F
C8	241100	Capacitor, Tantalum 10 μ F
C9	275104	Capacitor, Monolithic 50 V 0.1 μ F
C10	214103	Capacitor, Monolithic 50 V 0.01 μ F
C11	241020	Capacitor, Tantalum 2.2 μ F
C12	275104	Capacitor, Monolithic 50 V 0.1 μ F
C13	241020	Capacitor, Tantalum 2.2 μ F
C14	237101	Capacitor, Electrolytic 16 V 100 μ F
C15,C16	214103	Capacitor, Monolithic 50 V 0.01 μ F
C17		Not Used.
C18	275104	Capacitor, Monolithic 50 V 0.1 μ F
C19	241020	Capacitor, Tantalum 2.2 μ F
C20,C21	275104	Capacitor, Monolithic 50 V 0.1 μ F
C22	241020	Capacitor, Tantalum 2.2 μ F
C23		Not Used.
C24	241010	Capacitor, Tantalum 1.0 μ F
C25		Not Used.
C26	275104	Capacitor, Monolithic 50 V 0.1 μ F
C27,C28		Not Used.
C29	275270	Capacitor, Monolithic NPO 27 pF
C30	214103	Capacitor, Monolithic 50 V 0.01 μ F
C31	275104	Capacitor, Monolithic 50 V 0.1 μ F
C32-C34		Not Used.
C35	275104	Capacitor, Monolithic 50 V 0.1 μ F
C36	241020	Capacitor, Tantalum 2.2 μ F
CR1-CR9	320002	Diode, 1N4148
CR10		Not Used.
CR11	320002	Diode, 1N4148
CR12	320256	Diode, Zener 1N5346B
CR13		Not Used.
CR14	320002	Diode, 1N4148
DS1	320802	LCD, 6-digit
DS2	392001	Panel, Electroluminescent
L1	490201	Inductor, Ferrite Bead
J1	610235	Connector, PC Mount 4-pin
J2	610140	Connector, 7-pin
J3	610208	Connector, PC Mount 10-pin
Q1	310003	Transistor, NPN 2N3567
Q2	310057	Transistor, NPN PN2222A
Q3,Q4	310064	Transistor, NPN Darlington 2N6427
R1	113393	Resistor, Film 1/8 W 5% 39 k Ω
R2	113104	Resistor, Film 1/8 W 5% 100 k Ω
R3	113472	Resistor, Film 1/8 W 5% 4.7 k Ω
R4,R5	113224	Resistor, Film 1/8 W 5% 220 k Ω
R6	113223	Resistor, Film 1/8 W 5% 22 k Ω

TABLE 9-1.
Parts List, Display Board Module, M6, (Continued).

R7	113103	Resistor, Film 1/8 W 5% 10 k Ω
R8	113273	Resistor, Film 1/8 W 5% 27 k Ω
R9,R10	113473	Resistor, Film 1/8 W 5% 47 k Ω
R11	1113002	Resistor, Metal Film 1/8 W 1% 30 k Ω
R12	113103	Resistor, Film 1/8 W 5% 10 k Ω
R13	113682	Resistor, Film 1/8 W 5% 6.8 k Ω
R14	113103	Resistor, Film 1/8 W 5% 10 k Ω
R15	113334	Resistor, Film 1/8 W 5% 330 k Ω
R16		Not Used.
R17	113222	Resistor, Film 1/8 W 5% 2.2 k Ω
R18	1122001	Resistor, Film 1/4 W 1% 2 k Ω
R19	1123831	Resistor, Film 1/4 W 1% 3.83 k Ω
R20	170224	Resistor, Variable 1 k Ω
R21		Not Used.
R22	113561	Resistor, Film 1/8 W 5% 560 Ω
R23	113472	Resistor, Film 1/8 W 5% 4.7 k Ω
R24		Not Used.
R25	113102	Resistor, Film 1/8 W 5% 1 k Ω
R26	170221	Resistor, Trimmer 10 k Ω
R27		Not Used.
R28	113333	Resistor, Film 1/8 W 5% 33 k Ω
R29		Not Used.
R30	1131001	Resistor, Metal Film 1/2 W 1% 1 k Ω
R31	113223	Resistor, Film 1/8 W 5% 22 k Ω
R32	113152	Resistor, Film 1/8 W 5% 1.5 k Ω
R33	170224	Resistor, Variable 1 k Ω
RP1	182002	Resistor Pak, 9 x 100 k Ω
T1	410019	Transformer, 600- Ω line to 600- Ω line
U1	330360	IC, LCD Display Driver
U2	330343	IC, LM317LZ
U3	330341	IC, RE5VA21AC
U4	330342	IC, CD4093
U5	330343	IC, LM317LZ
U6*	330055	IC, LM3914N
U7*	330345	IC, MC74HC147

* Part installed for extended control of PRC1077-RCH remote control handset.

CHAPTER 10

ANTENNA-TUNER MODULE, M7 - THEORY OF OPERATION

10-0 INTRODUCTION

The M7 module contains the antenna-tuner circuits and the T/R relay. It is contained on PCB 738004 which is mounted in a die-cast box on the bottom of the chassis next to the front panel (see Figure 1-4). Instructions for access and removal are given in section 2-5.2.

10-1 MODULE INTERCONNECTIONS

The M7 module has the following interconnections with the rest of the transceiver.

Connector M7J1 (see Figure 1-4 for location):

- Pin 1 RF Detector line to M1J2-6; see section 4-1.
- Pin 2 T(-) line to M3J6-5; see section 6-1.
- Pin 3 +12 Vdc, switched.
- Pin 4 TX+; +12 Vdc in TX mode.
- Pin 5 Data line from M3J3-5; data from the processor to program the tuner component settings.
- Pin 6 Clock line from M3J2-2; see section 6-1
- Pin 7 +5 Vdc, regulated.
- Pin 8 Latch "1" line from M3J2-1; see section 6-1.
- Pin 9 Latch "0" line from M3J2-4; see section 6-1.
- Pin 10 Ground.

10-2 CIRCUIT DESCRIPTION

The antenna tuner is designed to match two antennas over the frequency range 30-88 MHz. In a transceiver package configured as a packset there are many design problems. In theory, the antenna is tuned to quarter-wavelength resonance and presents a load impedance of 35 ohms. In the real world there is no true ground, and the capacitance from the antenna to the transceiver case, and the capacitance of the case to ground must be included in the matching equation. In practice, the capacitance of the transceiver case to ground is subject to substantial variations, and a perfect match is difficult to achieve. It is possible to design an antenna tuner that will automatically adjust the tuning network to give an excellent match under every operating condition. Unfortunately this slows the operation of the transceiver, and under practical operating conditions may not give the best results.

In this transceiver, the antenna tuner is programmed to give correct matching when the packset is in the typical operating configuration. The final amplifier is a broadband design that is capable of delivering full power output into a wide range of output impedances. In practice this combination gives excellent results. The antenna is tuned to the operating frequency in milliseconds and the broadband design of the final amplifier ensures that close to maximum power is always delivered to the load. The difference between the theoretically perfect match and the practical match in the transceiver is seldom greater than 1 dB. This

ratio does not cause any detectable reduction of the signal-to-noise ratio or the operating range of the transceiver.

Antennas

The transceiver uses two different antennas. The AT-892/U is 3-ft long and the AT-271A/U is 10-ft long. The AT-271A/U is used in conjunction with the flexible support AB-591/U. This support has an extension on the screw-in base that actuates a microswitch inside the transceiver. When the microswitch is actuated, the tuning program for the longer antenna is used.

Tuning Program

The tuning program for the antennas is programmed in the ROM (read only memory). The microprocessor checks the operating frequency, the type of antenna, and then selects the tuning network programmed in the ROM. The appropriate relays in the antenna tuner are then selected so that the antenna is correctly matched. This entire process takes only milliseconds, and the slowest part of the procedure is the closure of the relays. For practical purposes, the antenna tuning is instantaneous, and it is completely practical to operate semi-duplex (different transmit and receive frequencies) with the antenna tuner retuning between the transmit and receive modes.

Tuning Network

The antenna-tuning network is quite conventional. If the antenna is shorter than 1/4 wavelength, it is tuned to resonance by inserting series inductance. When the antenna is longer than 1/4 wavelength it is necessary to insert either series capacitance or shunt capacitance to ground in combination with a small series inductance. Above 1/2 wavelength the antenna is tuned to resonance with series inductance.

It is desirable to use a continuously variable capacitance and inductance in the antenna tuner. This would necessitate variable capacitors and inductors with either mechanical or motor drives. A practical alternative is the use of a series of switched capacitors and inductors. If the elements are arranged in a binary sequence with each element doubling in value, it is possible to tune the entire range of values in increments of the smallest element. Five inductors are used in the transceiver, ranging from 0.06 microhenry to 1 microhenry. These inductors are connected in series and have a total inductance of 1.94 microhenrys. Each inductor may be shorted by a relay. By shorting the appropriate inductors using a binary switching progression, it is possible to adjust the inductance from 0 to 1.94 microhenrys, in increments of 0.06 microhenry. Similarly, the shunt capacitors may be selected to give four values of capacitance from 0-33 pF. A single series

capacitor is used for antennas that are longer than 1/4 wavelength.

Latching Relays

The antenna tuner uses latching relays so that no power is used when the tuning operation is complete. The latching relays have two coils, one to close the contacts and the other to open the contacts. The relay is maintained in the open or closed condition by small permanent magnets. This means that the relays require a short power pulse to operate and no sustaining current is required. The relays are controlled by the switching transistors Q5 to Q12. When the base of the transistor receives forward bias from the shift register, it completes the relay circuit to ground. Two latches comprising transistors Q2/Q4 and Q1/A3 are used to apply the +12 V to either the coils to open the relays or the coils to close the relays.

Tuning Control

Two tuning programs are stored in the ROM. The program for the 3-ft antenna is selected unless the microswitch at the base of the antenna (S7) is closed. S7 selects the program for the 10-ft antenna, and the switch is activated by a plunger on the antenna base. The microprocessor selects the correct tuning program for the operating frequency and sends this information in serial form on the data line. The serial data is converted to parallel information in the shift register U1. The outputs from the register operate the relay drivers Q5-Q12. The microprocessor also sends out the

latching information to determine if the relays are to be opened or closed.

One pole of K9, a DPDT sealed relay, is used to switch the antenna from receive to transmit. The other pole of the relay switches the 12 V to the T+ rail.

Q13 is used as the RF detector and switches low when RF output is detected. The logic in the audio module switches off the side tone if there is no RF output to indicate to the operator there is a problem in the transmitter. The RF voltage is sampled by C7 and rectified by D17. This applies a forward bias to Q13 making the collector voltage go low.

10-3 VOLTAGE CHARTS

Table 10-4 shows the dc voltage levels on the M7 transistor and IC pairs.

10-4 TEST AND ALIGNMENT

Module Test

The M7 module test is defined by TWC test procedure #991438. This procedure requires the use of a special test fixture and is not included in this manual. Information on the special fixture, in addition to a copy of the module test procedure, may be obtained from the factory upon request.

Alignment

The tuner coils are aligned at the factory and no field alignment is possible without the fixture.

**TABLE 10-1.
M7 Dc Voltage Levels.**

<u>LOCATION</u>				<u>VOLTAGE</u>				<u>LOCATION</u>		<u>VOLTAGE</u>		<u>LOC.</u>	<u>VOLTAGE</u>	
<u>J1</u>	<u>PIN</u>	<u>RX</u>	<u>TX</u>	<u>U1</u>	<u>PIN</u>	<u>RX</u>	<u>TX</u>	<u>PIN</u>	<u>RX</u>	<u>TX</u>		<u>RX</u>	<u>TX</u>	
	1	13.40	0.0		1	5.0	4.9	9	—	4.4				
	2	13.75	0.2		2	—	—	10	—	4.3				
	3	13.75	13.5		3	—	—	11	—	4.0				
	4	—	13.4		4	—	—	12	—	2.0				
	5	—	—		5	—	—	13	—	2.1				
	6	—	—		6	4.5	—	14	4.5	3.3				
	7	4.9	4.9		7	4.5	—	15	4.9	4.9				
	8	—	—		8	—	—	16	4.9	4.9				
	9	—	—											
	10	—	—											
<u>Q1</u>	<u>RX</u>	<u>TX</u>		<u>Q2</u>	<u>RX</u>	<u>TX</u>		<u>Q3</u>	<u>RX</u>	<u>TX</u>				
C	13.7	13.5		C	13.7	13.5		C	0.1	9.1				
B	—	—		B	—	—		B	13.7	13.5				
E	—	—		E	—	—		E	13.7	13.5				
<u>Q4</u>	<u>RX</u>	<u>TX</u>		<u>Q7</u>	<u>RX</u>	<u>TX</u>		<u>Q5-Q12</u>						
C	0.1	8.5		C	0.0	0.5		Same as Q7 when selected.						
B	13.7	13.5		B	0.7	0.0								
E	13.7	13.5		E	—	—								
<u>Q13</u>	<u>RX</u>	<u>TX</u>												
C	13.4	0.0												
B	—	0.8												
E	—	—												

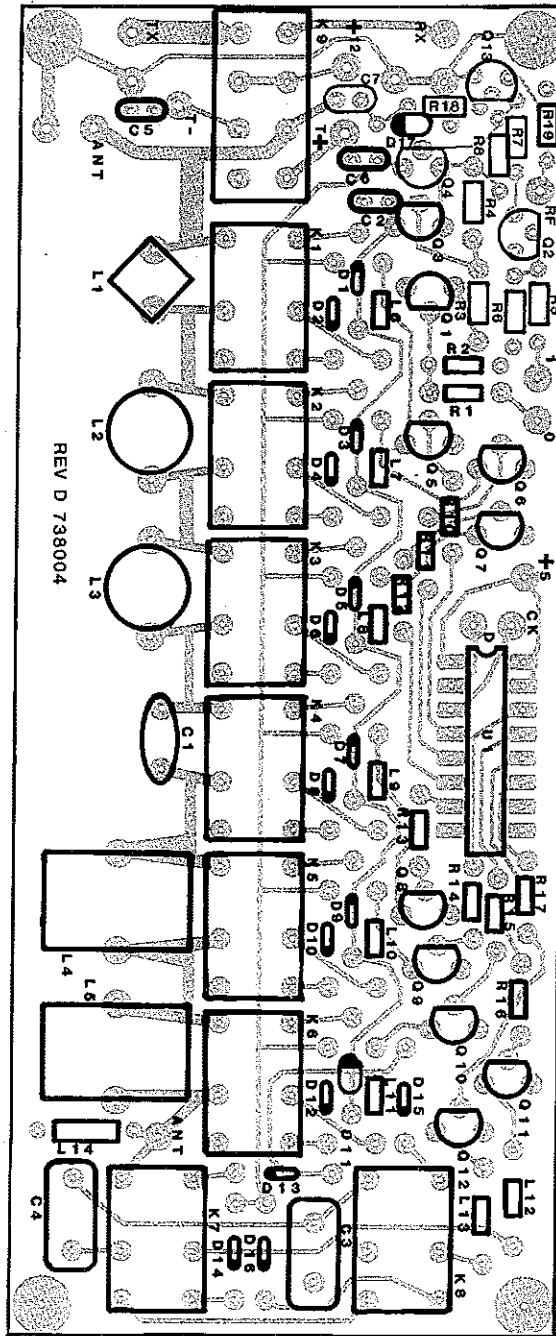

FIGURE 10-1.
Component Locations, Antenna-Tuner Module, M7.

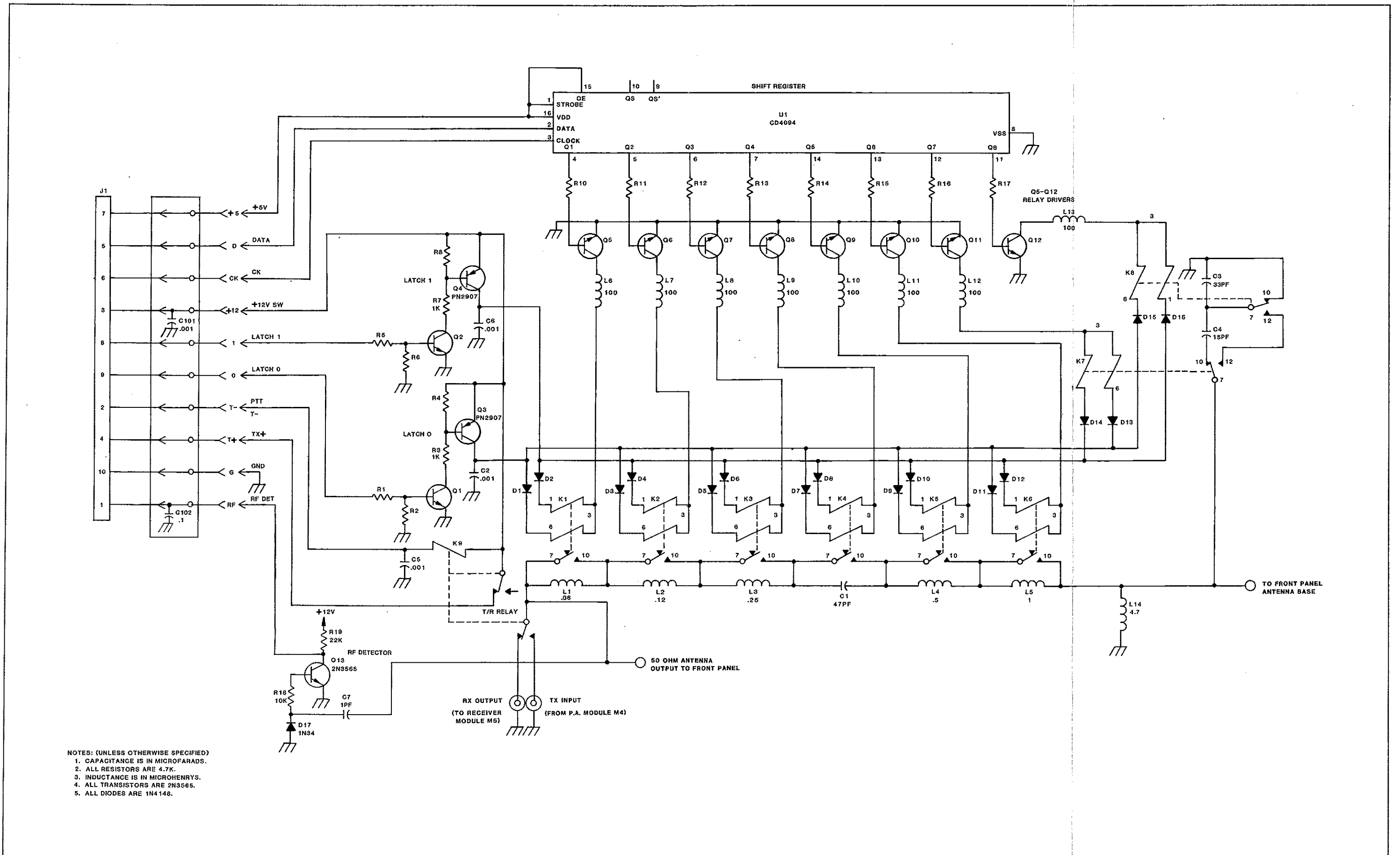
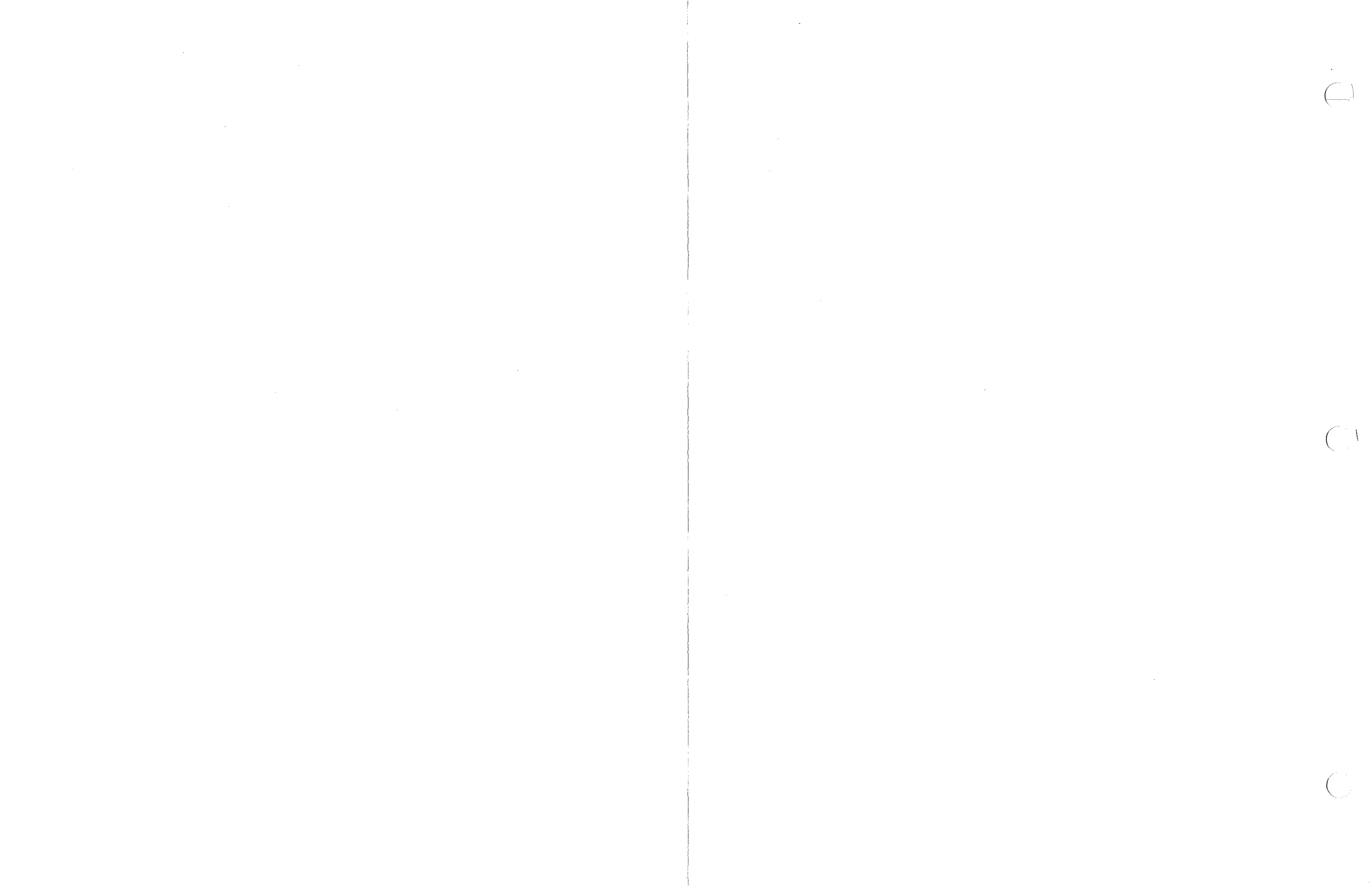

FIGURE 10-2. Schematic Diagram, Antenna-Tuner Module, M7.



**TABLE 10-2.
Parts List, Antenna-Tuner Module, M7.**

C1	220470	Capacitor, Mica DM15 47 pF
C2	210102	Capacitor, Disc .001 μ F
C3	220330	Capacitor, Mica DM15 33 pF
C4	220150	Capacitor, Mica DM15 15 pF
C5,C6	210102	Capacitor, Disc .001 μ F
C7	210010	Capacitor, Disc NPO 1 pF
C8-C100		Not Used.
C101	210102	Capacitor, Disc .001 μ F
C102	275104	Capcitor, Monolithic 50 V 0.1 μ F
D1-D16	320002	Diode, 1N4148
D17	320003	Diode, 1N34A
K1-K8	540066	Relay, Latchseal, 12 Vdc
K9	540010	Relay, DPDT 12 Vdc
L1	490112	Inductor, Variable 2.5 turns 0.06 μ H
L2	490117/490504	Inductor, Variable 3.5 turns 0.25 μ H
L3	490126	Inductor, Variable 6.5 turns 0.125 μ H
L4	459156	Inductor, Toroid 6 turns 0.5 μ H
L5	459157	Inductor, Toroid 8 turns 1 μ H
L6-L13	430040	Inductor, 100 μ H
L14	430028	Inductor, Molded Fixed 4.7 μ H
Q1,Q2	310006	Transistor, NPN 2N3565
Q3,Q4	310052	Transistor, PNP PN2907A
Q5-Q13	310006	Transistor, NPN 2N3565
R1-R2	113472	Resistor, Film 1/8 W 5% 4.7 k Ω
R3	113102	Resistor, Film 1/8 W 5% 1 k Ω
R4-R6	113472	Resistor, Film 1/8 W 5% 4.7 k Ω
R7	113102	Resistor, Film 1/8 W 5% 1 k Ω
R8	113472	Resistor, Film 1/8 W 5% 4.7 k Ω
R9		Not Used.
R10-R17	113472	Resistor, Film 1/8 W 5% 4.7 k Ω
R18	113103	Resistor, Film 1/8 W 5% 10 k Ω
R19	113223	Resistor, Film 1/8 W 5% 2.2 k Ω
U1	330126	IC, CD4094BE/MC14094BCP

C

C

C

CHAPTER 11 CHASSIS/MAINFRAME

11-1 GENERAL

This chapter contains information on the mainframe components not covered elsewhere, as well as an overall wiring diagram of the transceiver. Figure 11-1 shows the

top-view module locations; Figure 11-2 shows the bottom-view module locations. Figure 11-3 is the mainframe schematic diagram and the parts are specified in Table 11-1.

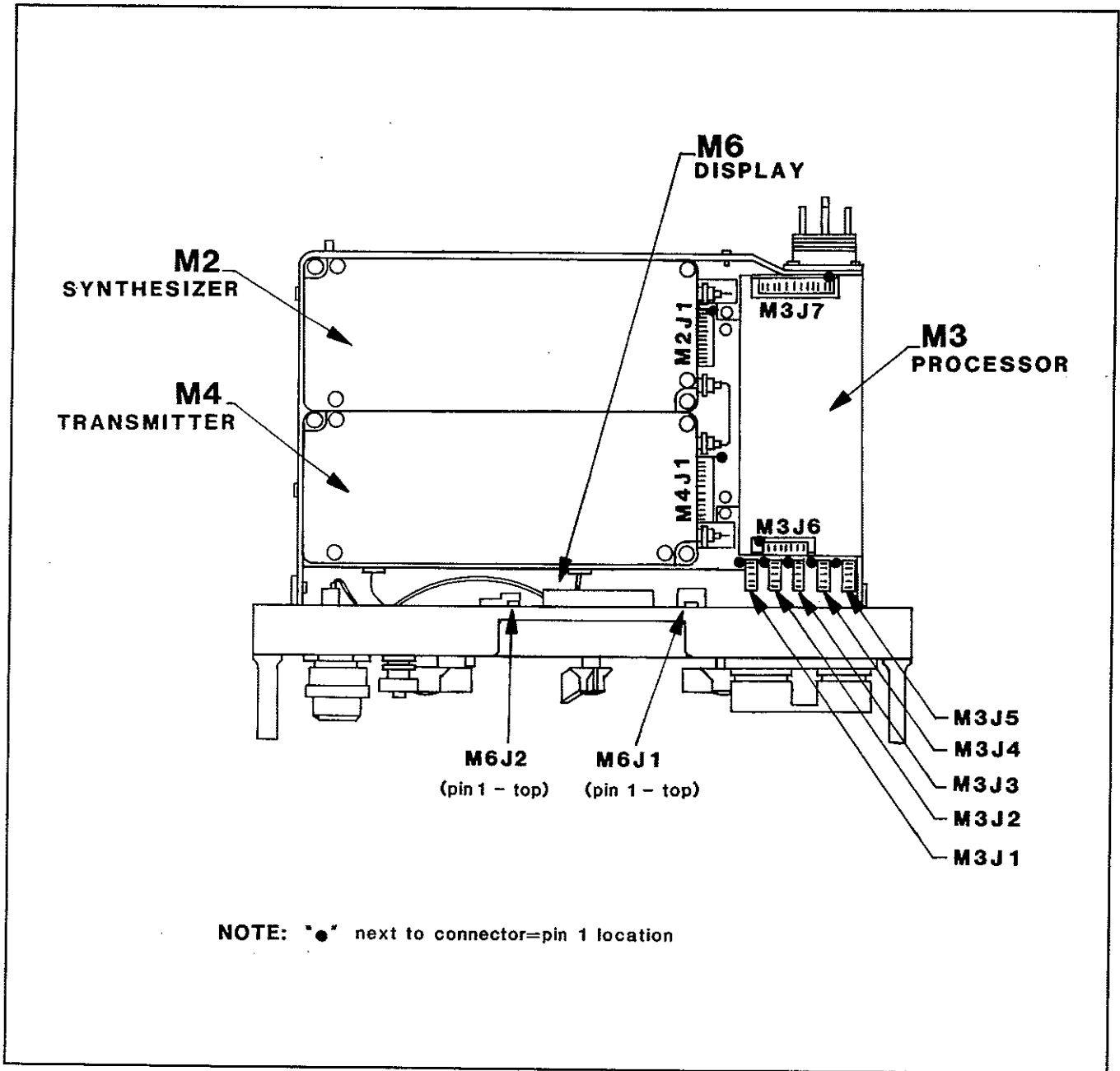
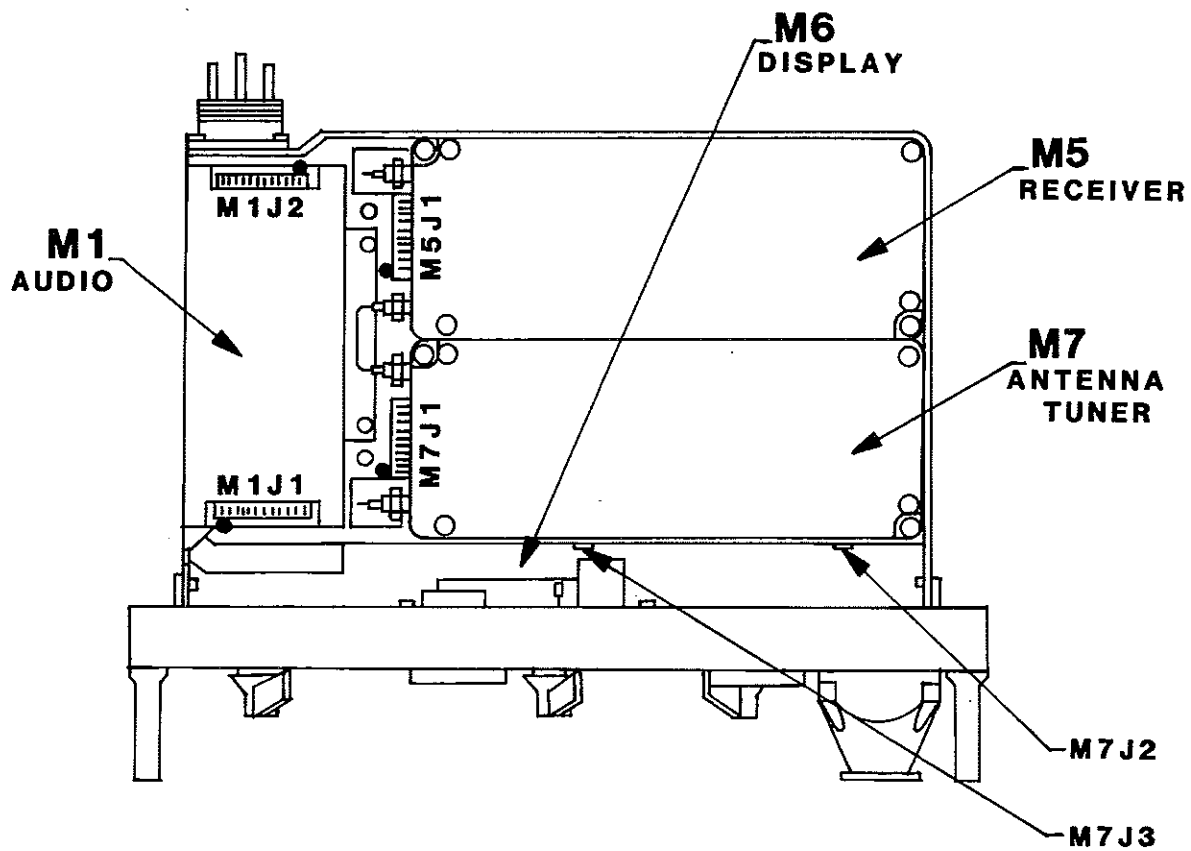

FIGURE 11-1.
Module Locations, Top View.



NOTE: '•' next to connector=pin 1 location

FIGURE 11-2.
Module Locations, Bottom View.

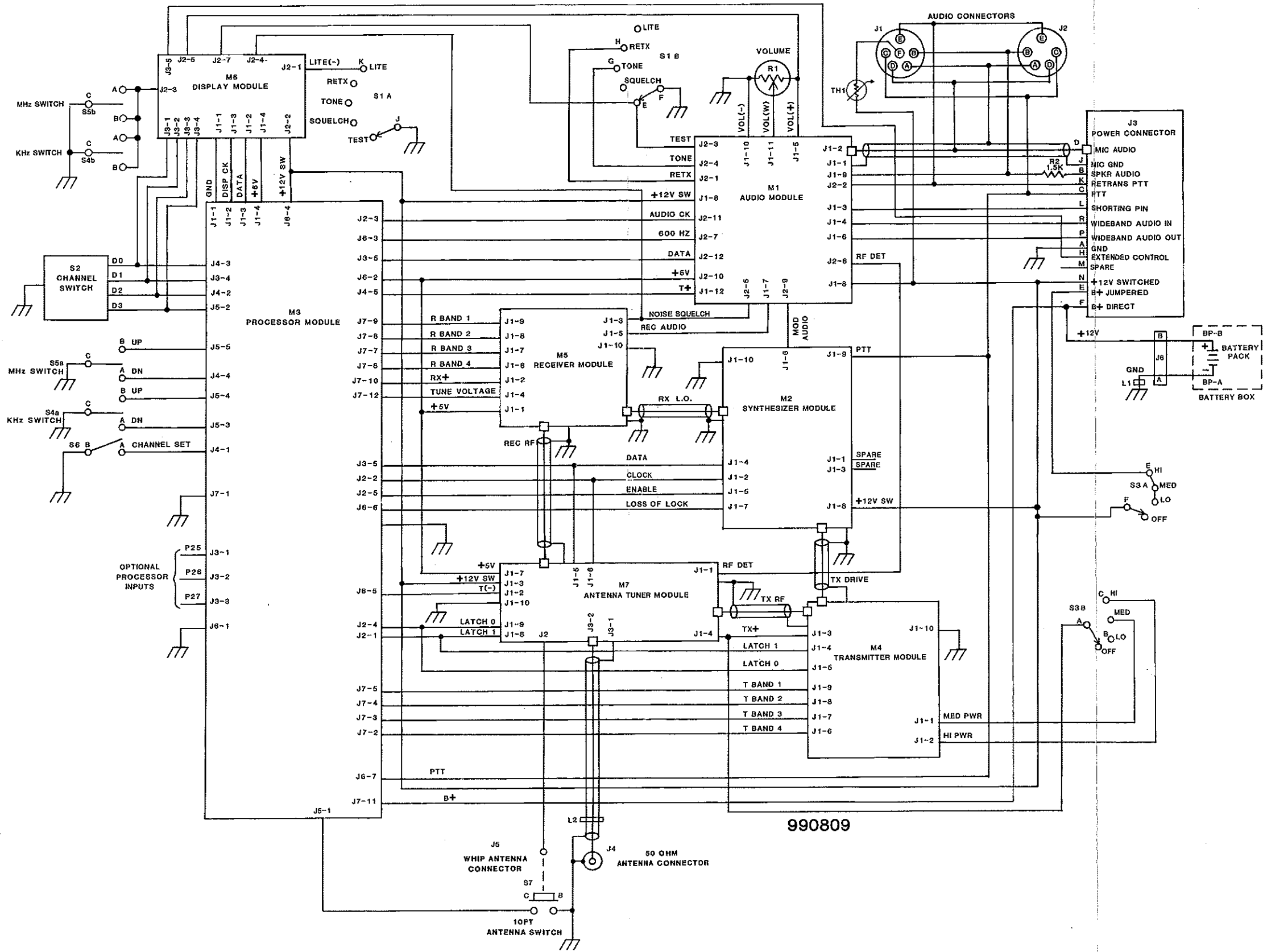

FIGURE 11-3. Schematic Diagram, Mainframe.

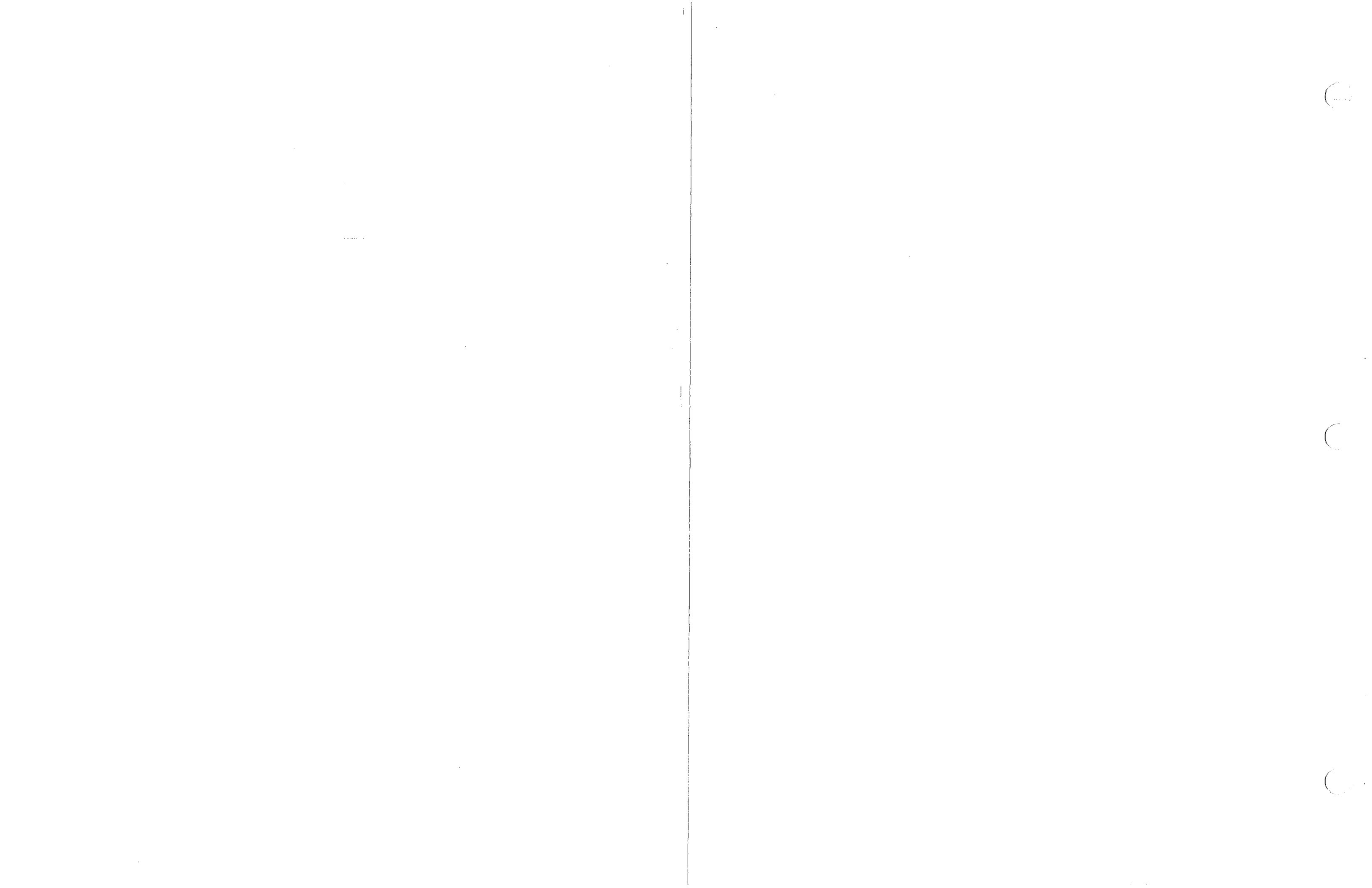
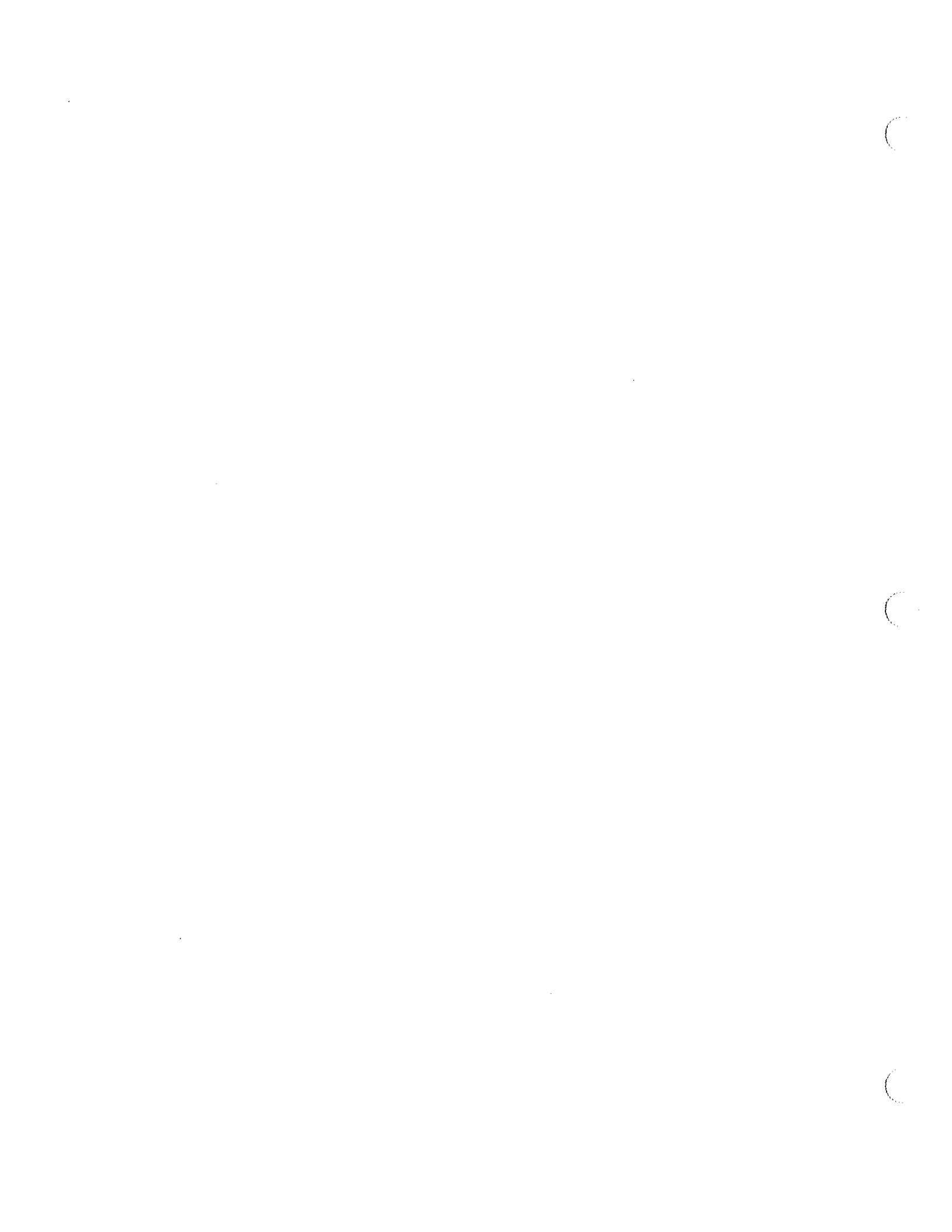

TABLE 11-1.
Parts List, Mainframe.

J1	613090	Connector, Audio
J2	610080	Connector, Audio
J3	610089	Connector, Power
J4	610084	Connector, 50-ohm Antenna
J5	610087	Connector, Whip Antenna
J6	610086	Connector, Battery Pack
L1	490201	Inductor, Ferrite Bead
L2	490203	Inductor, Ferrite Bead
R1	170015	Resistor, Potentiometer 10 k Ω
R2	113152	Resistor, Film 1/8 W 5% 1.5 k Ω
S1	510026	Switch, Function
S2	510028	Switch, Channel
S3	510027	Switch, Power
S4	510029	Switch, kHz Tuning
S5	510029	Switch, MHz Tuning
S6	530025	Switch, Channel Set
S7	532005	Switch, Antenna
TH1	350111	Thermistor, 5 Ω 25 $^{\circ}$ C



CHAPTER 12

TACSEC EMBEDDED TACTICAL SECURITY OPTION

12-1 INTRODUCTION

The TACSEC device option when fitted to the PRC1077 provides embedded tactical voice security. This voice security is achieved by the use of a security device module fitted underneath the M1 audio module.

Operation in this mode is achieved by switching the radio to the "RX Test" position. The "normal" operation of this switch position is no longer available.

NOTE

Correct switch position selection is not required in the "RX" mode as the security device will decode ALL received signals with the correct security key regardless of front-panel switch settings.

Operation in the "RETX" mode requires the "RETX" cable to be placed on the outer front-panel audio connector, identified with a black anodized ring. Failure to use this port will result in "clear" speech being transmitted across the "RETX" link.

12-2 TECHNICAL DESCRIPTION

The voice-scrambler option provide scrambling in the frequency domain by utilizing an extremely complex series of pseudorandom "frequency hops" to invert and shift the frequency spectrum of the voice. These "frequency hops" occur at very irregular time intervals, which provides much greater security than simple "rolling-code" scramblers. The security device is capable of holding 16 user-programmable "keys" at one time. Each user "key" has over 1 million combinations available.

12-2.1 Programming Options

The initial programming of the security device will have been determined at the time of order. Should alterations to the basic operation of the device be required, then the use of a modem (option) and computer is required.

12-3 OPTIONS

12-3.1 Automatic Number Identification

This feature provides the user with the ability to monitor the use of a given radio by automatically logging, using a computer, the unit number of the radio each time the radio is keyed in the "RX Test" position.

12-3.2 "Stunning"

This enables an operator to remotely disable the radio so that it can neither transmit nor receive. A "stunned" radio can however be interrogated by the modem and forced to transpond for DF purposes. This feature could, for example, be used to locate stolen radios.

12-3.3 Key Change

Remote key changes/unit ID changes are possible without the radio being returned to the depot, as long as the radio is within the reception range of the computer/modem.

Other options are available when using the computer/modem combination and these are described in the modem instruction manual.

12-4 CIRCUIT DESCRIPTION

Due to the nature of the security device no explanation of the internal operation will be given. There are no user-serviceable parts inside the module. Should a security-device module be deemed defective, it should be returned to the factory for service.

The security device operates by intercepting the TX and RX audio paths in the radio, processing the audio, and then returning the audio to its original destination.

Transmit Mode

When the PTT button on the handset is depressed, the PTT signal is sent to the M1 audio module, connector J4-1, and in turn to connector J3-12. This signal instructs the microprocessor in the security module to "wake-up", and begin operation. Once the microprocessor has determined the coding sequence it will use for this transmission, it causes connector J3-11 to go low, which activates the main PTT line in the radio. This accounts for the perceptible delay in TX output once the PTT has been pressed.

The microphone audio path is via connector M1-J1-2, to M1-J3-5. At this point the audio is processed by the security module and presented to M1-J3-4 where it is attenuated and looped back into the main audio path, via M1-J3-3 and M1-J3-2 (linked together). The transmit path is now that of a nonsecure PRC1077. (See module M1, "Theory of operation.")

Receive Mode

When in the RX mode the audio path is that of a stock PRC1077 until the RX audio signal leaves IC U3B-7 in the M1 audio module. At this point the audio is attenuated by resistors R64 and R65, and is presented to the security device, M1-J3-7. The audio signal is then decoded and output to M1-J3-6. The remainder of the audio path within the PRC1077 is now that of a nonsecure radio. (See module M1, "Theory of operation.")

12-5 RADIO OPERATING INSTRUCTIONS

1. Turn radio to "ON" position.
2. For normal nonsecure transmissions, select either "SQUELCH," or "TONE" mode.
3. For secure transmissions, select "RX TEST" position.

4. Connect handset to the **INNER** of the two front-panel audio connectors.
5. When transmitting, audio sidetone in handset will sound scrambled.

NOTE:

Begin speaking after the end of the TX data burst (approximately 0.5 seconds).

6. When in "receive" mode, the radio will decode a valid scrambled signal regardless of the mode switch position.

NOTE:

Mode switch **MUST** be in "RX TEST" mode for secure transmission.

"RETX" Operation

1. Set radios in "RETX" mode.
2. Connect "RETX" cable to the **OUTER** audio connector (identified by a black anodized ring).

NOTE:

Inner audio connector **MUST** not be used for "RETX." If used, "clear" retransmission of the signal will result.

3. Select "RETX" frequencies.
4. Operation is that of a normal "RETX" link.
5. Secure radios using the "RETX" link can be in either "SQUELCH," "TONE," or "RETX" modes. Nonsecure radios using the "RETX" link can only use "TONE" or "RETX" modes.

**TABLE 12-1.
Fault Determination Guide.**

Fault Determination Guide.

No Transmit (Scramble mode)

- a. Check for MIC. Audio at M1-J3-5.
- b. Check for Audio at M1-J3-4 (Scrambled).
- c. Check for audio at M1-U1B-7(Scrambled).
- d. Check M1-J3-12 for PTT Signal
- e. Check M1-J3-11 for ECHO PTT (Delayed).

The presence of all of these signals would indicate a fault elsewhere in the radio. The absence of items b. or e. may indicate a fault in the security device. If possible substitute the security device for a known operational unit.

No Receive (Any mode)

- a. Check for audio output at M5-J1-5.
(Ensure radio on correct frequency.)
- b. Check for audio at junction R64,R65.
- c. Check for audio at M1-J3-6.

The presence of all of these signals would indicate a fault elsewhere in the radio. The absence of audio at M1-J3-6 (assuming its presence at junction R64,R65) may indicate a fault in the security device. If possible substitute the security device for a known operational unit.

No Receive/Garbled Receive

- a. Check audio at M5-J1-5.
- b. Substitute security device with known operational unit.
- c. Attempt to reprogram security device with security key. (Internal key may have become corrupted.)

Emergency Repair Instructions

Should either the security device be found defective—and no replacement is immediately available, or the security device function is no longer required, nonsecure operation of the radio can be quickly restored.

1. Unplug connector M1-J3.
2. Link M1-J3-6 to M1-J3-9.
3. Link M1-J3-2 to M1-J3-5.
4. Link M1-J3-11 to M1-J3-12.

These changes will restore nonsecure radio function.

NOTE: "RX Test" function will operate as "Tone-Squelch" mode.



APPENDIX A

A-1 GENERAL

A basic knowledge of the major techniques used in the synthesizer is necessary for both understanding and troubleshooting these circuits. Four separate VCO's are used to cover the frequency range from 30 to 87.975 MHz. During transmit the synthesizer is locked directly on the transmit frequency. During receive the synthesizer is reprogrammed to a frequency offset by the amount of the I.F.

Another important concept used in the design of the synthesizer is dual-modulus prescaling. The knowledge of this concept is important in the understanding of the synthesizer design.

This section includes a block diagram of the overall synthesizer. The description of the block diagram is shown in relation to the techniques of the phase-locked loop and dual-modulus prescaling in order to give a better understanding of the operation of the synthesizer.

Also shown in this section is a description of the frequency scheme used in the transceiver. Numerical examples are provided to clearly illustrate this approach. The overall frequency stability of the transceiver is also discussed.

A-2 BLOCK-DIAGRAM DESCRIPTION

A block diagram of the synthesizer is shown in Figure A-1.

A-2.1 PROGRAMMING SIGNALS

The programming of the synthesizer is accomplished by a 19-bit serial-data stream. This data controls the functions of the frequency synthesizer and originates from the microprocessor.

Nineteen clock pulses clock the data into the shift register contained in the MC145156 frequency-synthesizer integrated circuit. After the data has been loaded, it is latched into the main synthesizer control registers in the MC145156 by a single pulse on the ENABLE line, again originating in the microprocessor.

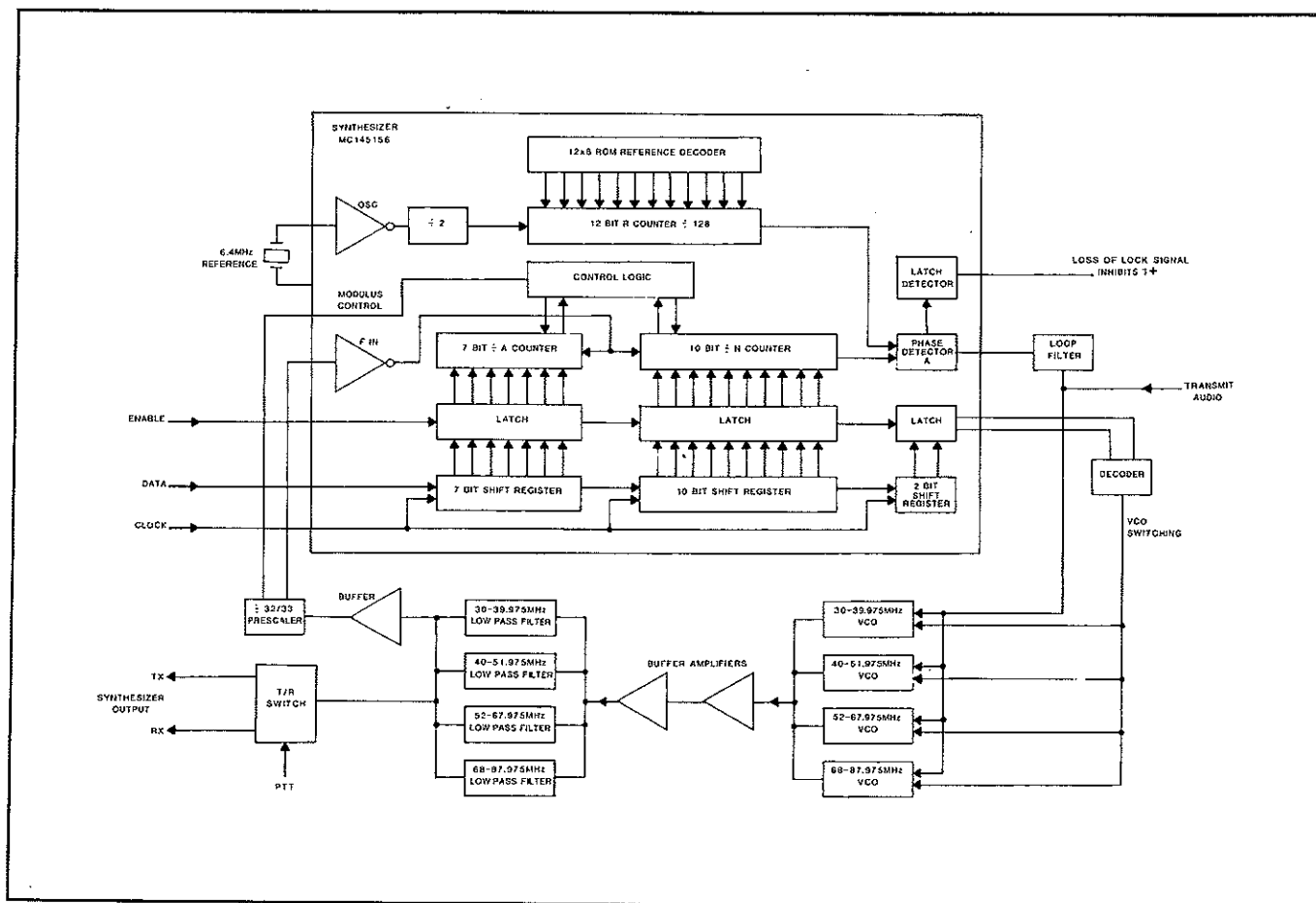

FIGURE A-1.
Synthesizer Block Diagram.

A-2.2 VCO BAND SELECTION

The first two bits of the serial-data stream are used to select the proper VCO. The four separate VCO bands used to cover the range of 30 to 87.975 MHz are:

BAND 1:	30 - 39.975 MHz
BAND 2:	40 - 51.975 MHz
BAND 3:	52 - 67.975 MHz
BAND 4:	68 - 87.975 MHz

The VCO is selected by applying +10 V to apply operating voltage for the VCO transistor. The output of the VCO is diode switched into a common buffer amplifier. The harmonics of the buffer amplifier are attenuated by one of four low-pass filters, selected to correspond to the operating VCO. The filtered output is diode switched between the TX and RX port.

A-2.3 PHASE DETECTOR

The phase detector generates an error voltage which causes the synthesizer to lock onto the desired frequency. The reference frequency is generated by a 6.4-MHz temperature-compensated crystal oscillator. This signal is divided by a reference divider contained in the MC145156 synthesizer IC to 25-kHz. This corresponds to the channel spacing. The 25-kHz signal is fed into the reference input of the phase detector, also contained in the MC145156. The variable input is obtained from the output of the low pass filters. A buffer amplifier isolates and feeds the $\div 32/33$ prescaler. The signal is then further divided by the programmable counter contained in the MC145156. The variable signal is fed to the variable input of the phase detector.

The phase detector compares the frequency and phase of the reference and variable-frequency inputs and generates an error voltage which tunes the VCO, so that the reference and variable frequency inputs are equal.

A-3 PHASE-LOCKED LOOPS

The heart of each synthesizer is the phase-locked loop (PLL), a simplified diagram of which is depicted in Figure A-2. Referring to this diagram, it is seen that a PLL consists of the following basic elements:

1. A Voltage-controlled oscillator (VCO).
2. A phase detector.
3. A divider; either fixed ($\div M$) or variable ($\div N$).
4. A loop filter.

The purpose of a PLL is to provide a VCO, which operating alone might be unstable, with the stability and accuracy of a single, highly-stable reference frequency. The inputs to the phase detector are a reference frequency (generally a very stable crystal oscillator), and the VCO output frequency divided by the integers $N \times M$. The phase detector dc output controls the VCO frequency and, under proper PLL conditions will change the VCO frequency (divided by $M \times N$) to equal the reference frequency. The $\div M$ is generally a fixed divider called a prescaler, whose purpose is to reduce a high VCO frequency to a lower level that can be handled by a standard programmable logic system.

The $\div N$ can be either a fixed or a variable divider. When N is variable, it can be programmed externally to change the VCO frequency in discrete steps. The phase detector will electronically tune the VCO each time N is changed to bring the output of the divider to the same frequency and phase as that of the reference. The loop is locked when $F_{out} = NMF_{ref}$.

Once the loop is locked, operation proceeds as follows: If the output frequency increases, the frequency out of the divider will exceed F_{ref} and the phase detector will react by trying to drive the VCO frequency lower. The tuning voltage to the VCO will decrease as a result, and the out-

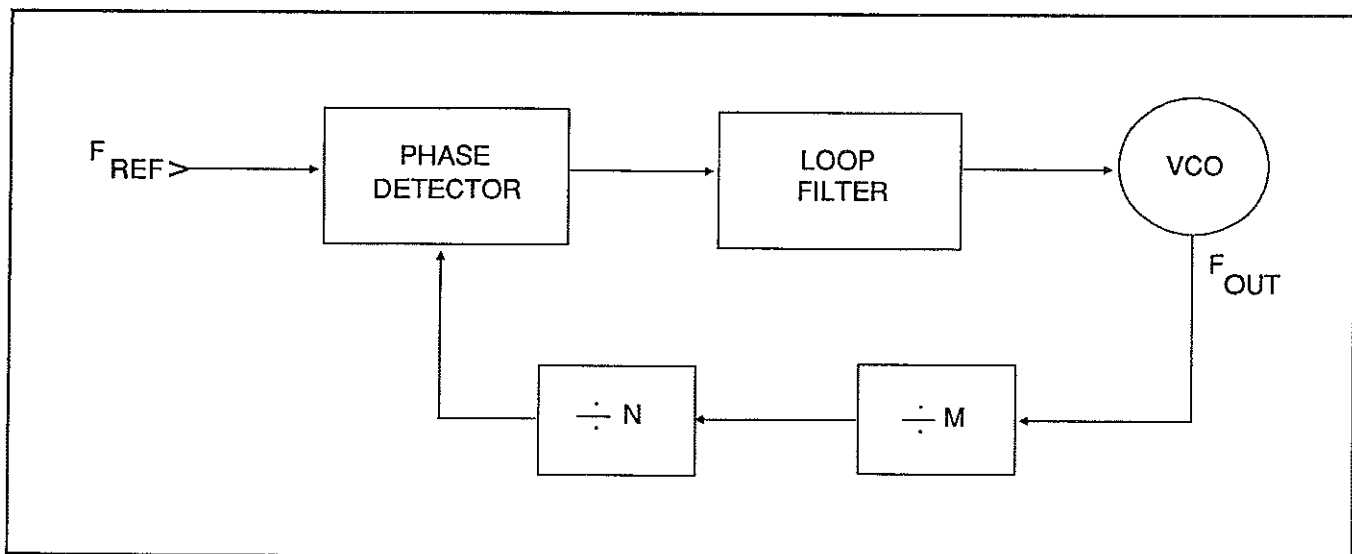

FIGURE A-2.
Phase Locked Loop.

put frequency will decrease, which counters the initial frequency increase. The loop filter is present to suppress undesired components produced in the phase detector so that they do not cause unacceptable FM on the VCO. The loop filter also has an important effect on other types of noise, the acquisition of lock, loop response time, and stability.

In a PLL synthesizer, the error signal driving the VCO changes value only once each reference period; the loop bandwidth, which determines response speed, is set to approximately 100 Hz. This is necessary for stability and for suppression of the reference-frequency sidebands, as well as for determining the lower frequency limit on modulation capability. The higher the reference frequency, the more the reference sidebands are suppressed, but the reference frequency also determines the minimum synthesizer channel spacing. For example, if the reference frequency is 25 kHz, the minimum channel spacing is 25 kHz. If the fixed divider M in Figure A-2 is greater than one, the F_{out} can only be changed in steps of MF_{ref} . If M is made equal to one, then the channel spacing depends only on F_{ref} .

A-4 DUAL-MODULUS PRESCALING

CMOS dividers provide not only the lowest power approach, but also the best approach for spectral purity because of their switching response. However, CMOS dividers are restricted in operating speed to below 10 MHz for reliable operation. With the Loop operating at up to 88 MHz, it is clear that some form of prescaling (or $\div M$) is required to reduce the VCO frequency to a level that can be handled by standard CMOS programmable dividers, and still provide the channel spacing of 25 kHz.

The synthesizers solve this problem by using a technique known as dual-modulus prescaling. This approach allows low-frequency CMOS-programmable counters to be used as high-frequency programmable counters with speeds of several hundred MHz. This is possible without the

sacrifice in channel spacing and performance that would otherwise result if a fixed divider was used for the prescaler ($\div M$). Prescalers are used whose division ratio can be switched between two values to allow effective division at the high prescaler input frequency (VCO output), with the actual programmable dividers operating at the lower output frequency of the prescaler.

Figure A-3 illustrates how a dual-modulus divider system operates. The VCO drives the dual-modulus prescaler (which can divide by P and P + 1), which in turn drives two programmable counters in parallel. These two counters are programmed to "A" and "N". The prescaler and the A-counter are connected in such a way that in a complete count cycle, the prescaler divides by P + 1 until the A-counter reaches zero and then reverts to a division ratio of P. Both the A-counter and the N-counter start counting at the same time. Both counters also reset at the same time. Therefore, the prescaler divides by P + 1 for "A" counts and by P for N-A counts. For example, the programmed divide ratio N_T is as follows:

$$N_T = (N-A)P + A(P + 1)$$

or

$$N_T = NP + A$$

Therefore, the overall divider system divides by P + 1 for as long a count as the A-counter is programmed (A counts), and then divides by P for the remainder of the cycle (N-A counts). The only restriction on the scheme is that the total count cycle (N) be greater than A.

For example, the 25-kHz loop synthesizer (as shown in Figure A-1) uses a $\div 32/33$ prescaler (an MC12015 rated at 200 MHz). The highest VCO frequency is 88 MHz,

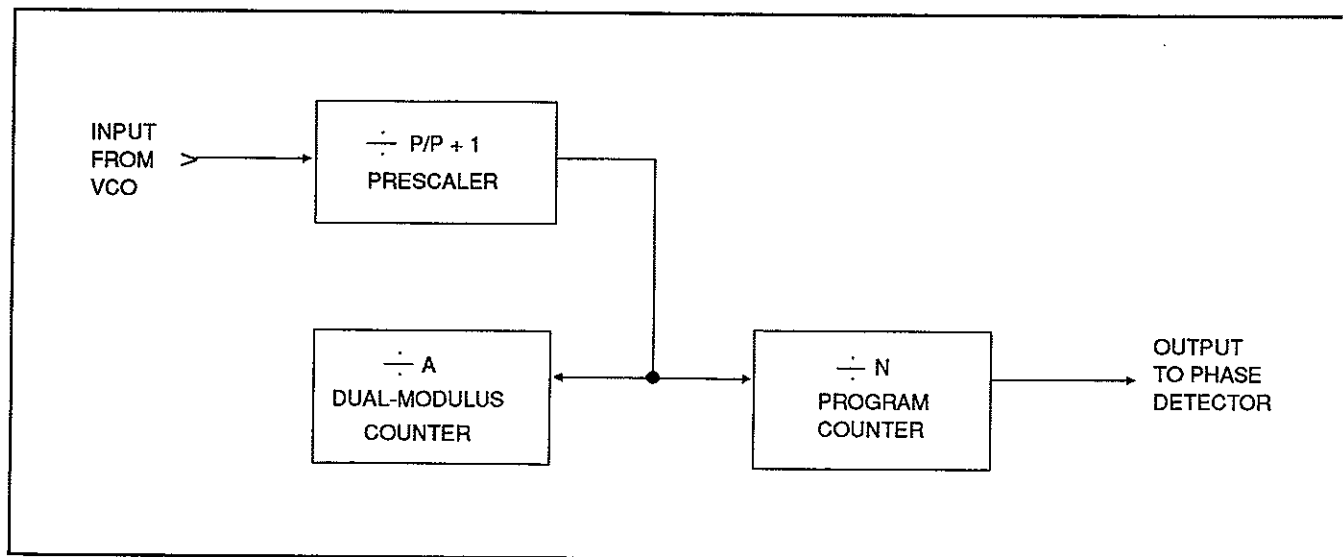

FIGURE A-3.
Dual Modulus Prescaler.

which when divided by 32 is less than 3, well below the 30-MHz MC145156 CMOS counting speed.

A-5 FREQUENCY PROGRAMMING

The frequency programming is performed by the microprocessor which calculates the proper $\div A$ and $\div N$ for the frequency selected. The input to the synthesizer is a 19-bit data stream generated by the microprocessor with the format shown in Figure A-4.

Bits 1 and 2 control the VCO band selection:

	<u>S0</u>	<u>S1</u>	
BAND 1	0	0	30 - 39.975
BAND 2	1	0	40 - 51.975
BAND 3	0	1	52 - 67.975
BAND 4	1	1	68 - 87.975

Bits 6 through 12 control the division ratio of the N counter. Bits 15 through 19 control the number of cycles through which the prescaler divides by 33 before switching to the divide by 32 mode.

The $\div N$ and $\div A$ counters are programmed in binary numbers, with the conversion being done by the microprocessor. The total division ratio equals $32N + A$. Therefore the channel frequency $F_c = (32N + A) \times 25$ kHz.

A-5.1 FREQUENCY PROGRAMMING EXAMPLE

Consider a channel frequency of 45.350 MHz. Then divide 45.350 MHz by 25 kHz = 1814 = $32N + A$; $1814 \div 32 = 56$ with a remainder of 22. Therefore $A = 22$ and $N = 56$.

The dual-modulus prescaler divides by 33 for 22 counts and then by 32 for 34 counts. Converted to binary $A = 1\ 0\ 1\ 1\ 0$ and $N = 0\ 1\ 1\ 1\ 0\ 0\ 0$. This is valid during transmit mode where the synthesizer frequency equals the channel frequency.

During receive the synthesizer operates at 10.7 MHz above 45.350 to give the I.F. offset of 10.7 MHz. The synthesizer operates at 56.050 MHz. $32N + A$ equals 2242; $2242 \div 32 = 70 +$ remainder of 2; $A = 2$, $N = 70$. The prescaler divides by 33 for 2 counts and then by 32 for 68 counts. Converted to binary, $A = 0\ 0\ 0\ 1\ 0$, $N = 1\ 0\ 0\ 0\ 1\ 1\ 0$.

A-6 FREQUENCY-CONVERSION SCHEME

During transmit the synthesizer operates directly on the channel frequency. During receive mode, the synthesizer is offset by the amount of the 10.7 MHz I.F. Each time the PTT is pressed or released, the microprocessor calculates the new programming information and loads it into the synthesizer. The microprocessor requires only a few milliseconds to accomplish this, allowing for semi-duplex operation with no limitation on TX-to-RX separation as long as the channels remain within the 30 to 87.975-MHz band.

To limit the range of the synthesizer in receive, high-side injection is used for channel frequencies of 30 to 51.975 MHz and low-side injection is used from 52 to 87.975 MHz. The synthesizer frequency equals $F_{ch} + 10.7$ MHz for channel frequencies below 52 MHz and $F_{ch} - 10.7$ MHz for channel frequencies 52 MHz and above.

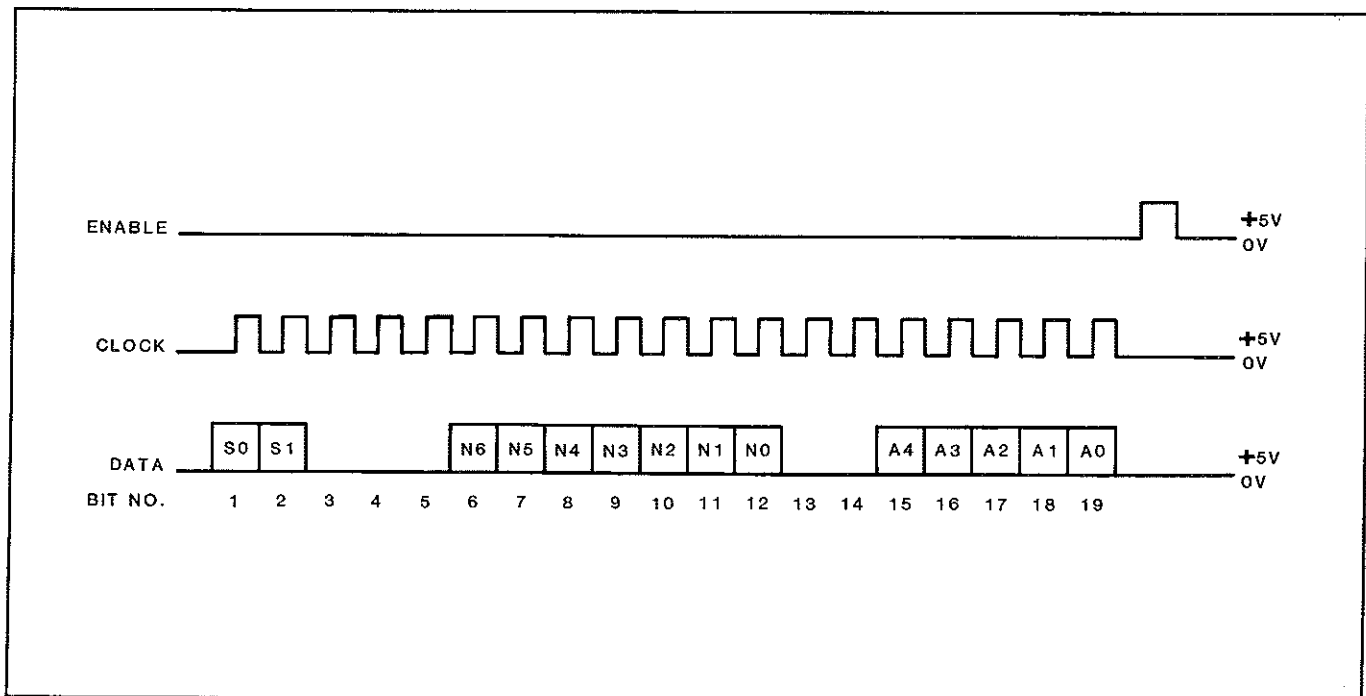

FIGURE A-4.
Serial Data Format.

APPENDIX B OPTIONAL ACCESSORY EQUIPMENT

B-1 GENERAL

This Appendix contains a list of optional accessory items for radio set PRC1077 as shown in Table B-1. It also includes instructions for using the major accessory items with the PRC1077.

B-2 EXPLANATION OF COLUMNS

An explanation of columns in Table B-1 is given below.

a. Stock number, column 1.

The manufacturer's stock number for the item is indicated in this column.

b. Description, column 2.

The item name and military part number (if used) are included in this column. Accessories are grouped in categories to assist in locating items of interest.

c. Unit of issue, column 3.

The unit used as a basis of issue (e.g. ea, pr, ft, yd etc) is located in this column.

d. Quantity used in (or with) unit, column 4.

The quantity of items used per radio/system is indicated in this column.

**TABLE B-1.
Optional Accessory Equipment.**

(1)	(2)	(3)	(4)
TWC STOCK NUMBER	DESCRIPTION	UNIT OF ISSUE	QTY USED PER UNIT
	<u>BATTERIES</u>		
BB-LA6:	Sealed lead-calcium rechargeable battery (6 Ah).	ea	1
BA6598/U:	BA6598/U high-capacity lithium battery (14 Ah).	ea	1
BB-NC4:	"D"-cell battery cassette for dry batteries or "D" nicad cells. NOTE: Only usable at 5-W power level with "D" dry batteries. Cassette only does not include batteries.	ea	1
BA4386/U	Medium-capacity magnesium dry battery (4 Ah) non-rechargeable.	ea	1
	<u>BATTERY CHARGERS/POWER SUPPLIES</u>		
PRC-PS:	Power supply//battery charger for sealed lead-calcium battery pack. Will operate radio while charging internal battery. Automatic rapid/taper charge characteristic; 115/230-Vac input. Separate charger circuit charges spare battery.	ea	1
PRC-BC4:	Multiple battery charger. 115/230-Vac, 24-Vdc input power. Charges up to 4 BB-LA6 lead-calcium battery packs simultaneously. Automatic rapid/taper charge characteristic. Individual charge status indicators.	ea	1
PRC-SPU-10:	Solar power generator for charging sealed lead-calcium battery pack. Portable, rugged unit can supply 10-W output.	ea	1
PRC-HC-30:	Portable hand-crank generator used for charging nicad or lead-calcium batteries. Rugged, compact unit that can supply 30-W output.	ea	1

**TABLE B-1.
Optional Accessory Equipment, Continued.**

(1)	(2)	(3)	(4)
TWC STOCK NUMBER	DESCRIPTION	UNIT OF ISSUE	QTY USED PER UNIT
PRC-HC-8:	Portable hand-crank generator used for charging nicad or lead-calcium batteries. Rugged, compact unit that can supply 8-W output.	ea	1
SF-281	Special power adapter for transportable 50-W system. Takes input +24 Vdc and provides +24 Vdc to the AM-1077 amplifier and +12 Vdc to the PRC1077 radio.	ea	1
	<u>POWER CABLES</u>		
PRC-CA12V:	12-V power cable allows operation of radio from 12-V source. Allows charging of lead-calcium BB-LA6 battery pack on radio direct from 12-V vehicle charging system. 12-V systems only—no lithium or dry battery charging.	ea	1
	<u>CARRYING ACCESSORIES</u>		
ST-138:	Standard military carrying harness with shoulder straps, frame, and securing straps for PRC1077.	ea	1
CW-503:	Accessory carrying bag. For PRC1077 antennas and handset. Attaches to ST-138 carrying harness.	ea	1
	<u>AUDIO ACCESSORIES</u>		
	All PRC1077 audio accessories are terminated with 5-pin twist-lock mil-spec connectors and are interchangeable between Transworld military products.		
H-250/U:	H-250/U Military handset. Noise cancelling.	ea	1
H-189/U:	H-189/U Military handset. Non noise cancelling.	ea	1
H-80/U:	M-80/U ruggedized hand microphone.	ea	1
H3M:	Headset-boom microphone. Single earphone low profile—will fit under GI Kevlar helmet with clip-on push-to-talk switch.	ea	1
H-140/U:	H-140/U ruggedized headphones with 5-pin mil-spec connector.	ea	1
KYR:	Morse key with 36-in cord and 5-pin mil-spec connector.	ea	1
LS-R:	Loudspeaker, allows loudspeaker monitoring of PRC1077 radio.	ea	1

**TABLE B-1.
Optional Accessory Equipment, Continued.**

(1)	(2)	(3)	(4)
TWC STOCK NUMBER	DESCRIPTION	UNIT OF ISSUE	QTY USED PER UNIT
	<u>MANPACK AND LONG-RANGE ANTENNAS</u>		
AT-271A/U-AB-591/U:	AT-271A/U 3-m folding whip antenna with AB-591/U flexible antenna base.	ea	1
AT-892/U	3-foot flexible tape whip antenna	ea	1
OE-254/GRC	Broadband omnidirectional antenna kit with mast used similarly to RC-292 to increase range between fixed portable sites.	ea	1
RC-292	Ground-plane antenna with mast; allows for long-range communication; lightweight.	ea	1
	<u>REPEATER ACCESSORIES:</u>		
1077RETRAN	Cable kit, retransmission—used to interconnect to PRC1077's for use as a retransmission station in applications over long-range paths in rough terrain that cannot be spanned with a single line-of-sight link.	ea	1
	<u>MOUNTS AND AMPLIFIERS:</u>		
MT-1077-24	24-V vehicular adapter with shock mount. Provides front-panel control and rear-panel control-cable interface to the AS-1729U military vehicular antenna used in vehicle configurations where drop-in interchangeability with the AN/VRC-64 or AN/GRC-160 vehicular radios is required. Control cable C991576 and power cable C991580 are ordered separately.	ea	1
MT-1077-12	12-V vehicular adapter with shock mount. Provides front-panel control and rear-panel control-cable interface to the AS-1729U military vehicular antenna used in vehicle configurations where drop-in interchangeability with the AN/VRC-64 or AN/GRC-160 vehicular radios is required. Control cable C991576 and power cable C991580 are ordered separately.	ea	1
AM-1077	33-88 MHz, 50-W power output amplifier for the PRC1077 radio, 24-Vdc operation only. Provides 50-W output from 30-88 MHz. Switched harmonic and low-pass filter, full compatibility with MT-1077 mount which is required for installation to PRC1077. PRC1077/MT-1077/AM-1077 combination is interchangeable with AN/VRC-12 and AN/VRC-46 radio families. RF cable C991575 and power cable C991579 are ordered separately.	ea	1

**TABLE B-1.
Optional Accessory Equipment, Continued.**

(1)	(2)	(3)	(4)
TWC STOCK NUMBER	DESCRIPTION	UNIT OF ISSUE	QTY USED PER UNIT
AM-1077ATU	AM-1077 automatic antenna tuner for AT271A/U 3-m whip antenna. Permits portable manpack operation of PRC1077/AM-1077 high-power system with external portable power source. RF cable C991575 and power cable C991580 are ordered separately.	ea	1
	<u>VEHICULAR ANTENNAS</u>		
AT-1729VRC	Standard MIL-type, 1/2 wavelength semi-flexible whip vehicle antenna with integral motor driven base matching unit (MX-6707/U). Note: Frequency coverage is limited from 30-76 MHz with AS-1729. RF cable C991577 and control cable C991578 are ordered separately.	ea	1
BB-3088	30-88 MHz broadband vehicular antenna, center fed, omni directional whip. Mounting base and feedline identical to AS-1729/VRC. No tuning control required. Length 3.2 meters (10.5 ft). RF cable C991577 is ordered separately.	ea	1
RMB	Antenna vehicular mounting bracket. Ruggedized, open design allows easy access to antenna connections.	ea	1
	<u>VEHICULAR AUDIO ACCESSORIES</u>		
AN/VIC-1	Standard U.S.-military vehicular intercom system. Permits interconnection of up to two radios with up to 5 operator crew stations within many types of military vehicles. Utilizes AM-1780/VIC-1 amplifier and C-2299/C-2298 control boxes. The C-2298 control box permits automatic retransmission of received signals between the two radios. Audio interface is accomplished utilizing the STD vehicular crew communications helmet.	ea	1
AM-1780/VIC-1	Amplifier (with cables).	ea	1
C-2298/VRC	Control Box (ea.)	ea	1

B-3 INSTALLATION AND USE OF OPTIONAL ACCESSORY ITEMS

This section covers the installation and use of the PRC1077 with the following accessories:

1. PRC-PS
2. PRC-BC4
3. PRC-HC-30
4. PRC-SPU-10
5. AM-1077
6. MT-1077

B-4 BATTERY CHARGING USING THE PRC-PS POWER SUPPLY/CHARGER

a. The PRC-PS can charge a battery while it is attached to the radio set, and it can also operate the radio set while charging its battery. Operation is as follows:

1. Attach the transceiver with its battery to the PRC-PS as shown in Figure B-1.

2. Attach the PRC-PS to an appropriate power source, either:

- i) 115/230 Vac, or
- ii) 24 Vdc

3. Turn the transceiver on if both battery charging and radio operation is desired; leave the transceiver off if only battery charging is needed.

4. Turn the PRC-PS on and note the LED indicators:

- i) If the battery is not connected, not connected properly or is shorted, the "fault" LED will come on.
- ii) The "charging" LED will come on during a normal charge cycle.
- iii) The "ready" LED will come on when the battery is fully charged.

b. The PRC-PS can also charge another battery connected to it through a battery connector in the rear of the unit.

1. Attach a BB-LA6 to the PRC-PS as shown in Figure B-2.

2. Attach the PRC-PS to an appropriate power source.

3. Turn the PRC-PS on and note the LED indicators:

- i) If the battery is not connected, not connected properly or is shorted, the "fault" LED will come on.
- ii) The "charging" LED will come on during a normal charge cycle.
- iii) The "ready" LED will come on when the battery is fully charged.

B-5 BATTERY CHARGING USING THE PRC-BC4

a. Charging up to four BB-LA6 sealed lead-calcium battery packs at the same time is done as follows:

1. Attach the PRC-BC4 to an appropriate power source, either:

- i) 115/230 Vac, or
- ii) 24 Vdc

2. Attach the PRC-BC4 to the battery packs to be charged (Figure B-3).

3. Turn the PRC-BC4 on and note the LED indicators:

i) The "fault" LED will come on if the battery is not connected, not connected properly, or is shorted.

ii) The "charging" LED will come on during a normal charge cycle.

iii) The "ready" LED will come on when the battery is fully charged.

B-6 BATTERY CHARGING USING THE PRC-HC-30 HAND-CRANK GENERATOR

a) The standard method of battery charging using the PRC-HC-30 is shown in Figure B-4.

1. Attach the BB-LA6 battery needing charging to the PRC1077.

2. Attach the PRC-HC-30 to the PRC1077 transceiver.

3. Mount the PRC-HC-30 for convenient cranking.

4. Begin operating the PRC-HC-30 by rotating its handles.

b. If it is necessary to charge a battery directly from the PRC-HC-30 (Figure B-5):

1. Attach the BB-LA6 to the PRC-HC-30 as shown.

2. Mount the PRC-HC-30 for convenient cranking.

3. Begin operating the PRC-HC-30 by rotating its handles.

B-7 BATTERY CHARGING USING THE PRC-SPU-10 SOLAR POWER GENERATOR

a. The standard method of battery charging using the PRC-SPU-10 is shown in Figure B-6.

1. Unfold the PRC-SPU-10 and orient it for maximum exposure to the sun.

2. Attach the battery needing charging to the PRC1077.

3. Attach the PRC-SPU-10 to the PRC1077 transceiver.

b. If it is necessary to charge a battery directly from the PRC-SPU-10 (Figure B-7):

1. Unfold the PRC-SPU-10 and orient it for maximum exposure to the sun.

2. Attach the BB-LA6 to be charged to the PRC-SPU-10.

B-8 MOBILE 5-W SYSTEM OPERATION

a. The PRC1077 can be used in a mobile configuration as shown in Figure B-8.

NOTE

This system can be used with either 12- or 24-V vehicles; the only difference is that 12-V vehicle installations must use the MT-1077-12 mount while 24-V vehicle installations must use the MT-1077-24 mount. Everything else, including cabling, is the same.

1. The radio set must have its battery box attached.
2. Slide the PRC1077 into the MT-1077 mount and clamp it in place.
3. Attach the correct cables as indicated in Figure B-8.

B-9 MOBILE 50-W SYSTEM OPERATION

a. The PRC1077 can be used in a mobile configuration with the AM-1077 power amplifier as shown in Figure B-9.

NOTE

Only 24-V operation is possible in this configuration.

1. Attach the battery box to the PRC1077.
2. Slide the PRC1077 into the MT-1077 mount and clamp in place.
3. Attach the AM-1077 amplifier to the MT-1077 mount.
4. Hook up the correct cables as shown in Figure B-9.

B-10 MOBILE 5-W SYSTEM WITH U.S. MIL MOUNT

a. The PRC1077 can be used in a mobile configuration with the standard U.S. military mount as shown in Fig. B-10.

NOTE

This system can only be used in a 24-V vehicle.

1. Attach the battery box to the PRC1077.
2. Slide the PRC1077 into the OA3633/VRC mount and clamp in place.
3. Attach the OA3633/VRC to the MT1029/VRC mount and mount to the vehicle.
4. Hook up the correct cables as shown in Figure B-10.

B-11 MOBILE 50-W SYSTEM WITH U.S. MIL MOUNT

a. The PRC1077 can be used in a mobile configuration with the AM-1077 power amplifier and standard U.S. Military mount as shown in Figure B-11.

NOTE

This system can only be used in a 24-V vehicle.

1. Attach the battery box to the PRC1077.
2. Slide the PRC1077 into the OA3633/VRC mount and clamp in place.
3. Attach the OA3633/VRC to the MT1029/VRC shock mount and mount to the vehicle.
4. Hook up the correct cables as shown in Figure B-11.

B-12 MOBILE/PORTABLE 50-W SYSTEM

The PRC1077 can be used in a transportable configuration with the AM-1077 power amplifier as shown in Figure B-12. A special Power Adapter (SF-281) must be used to take +24-Vdc primary power input and provide + 24 Vdc to the AM-1077 and +12 Vdc to the PRC1077.

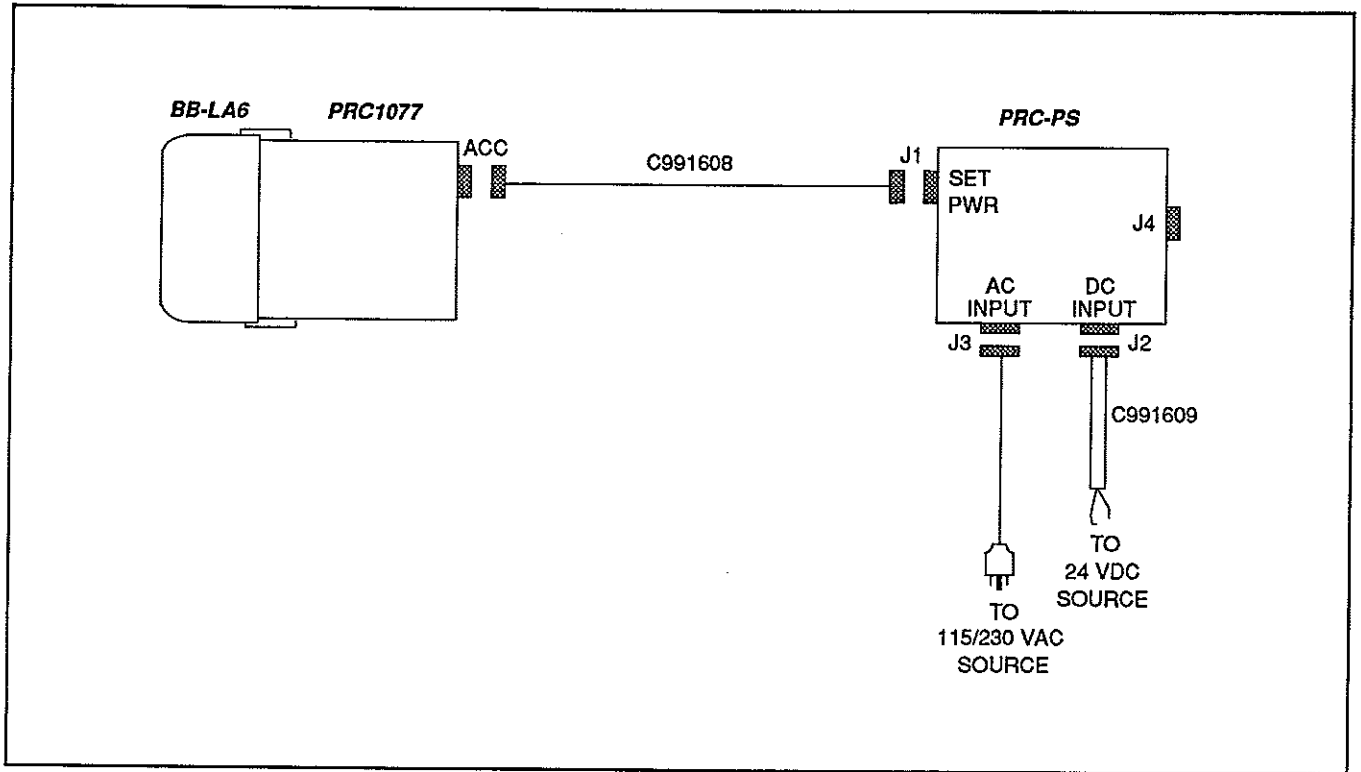

FIGURE B-1.
Operation of PRC-PS into PRC1077.

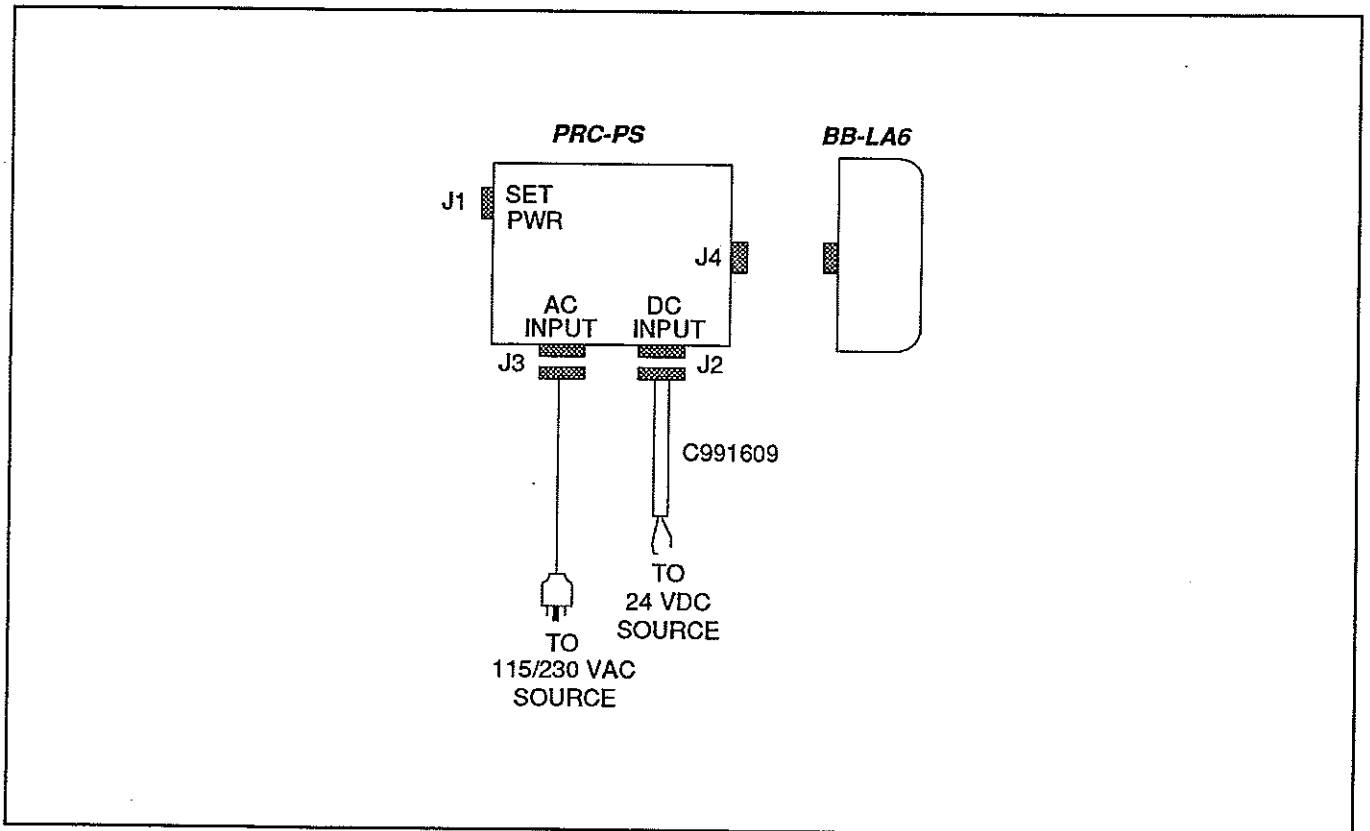

FIGURE B-2.
Operation of PRC-PS into Separate Battery.

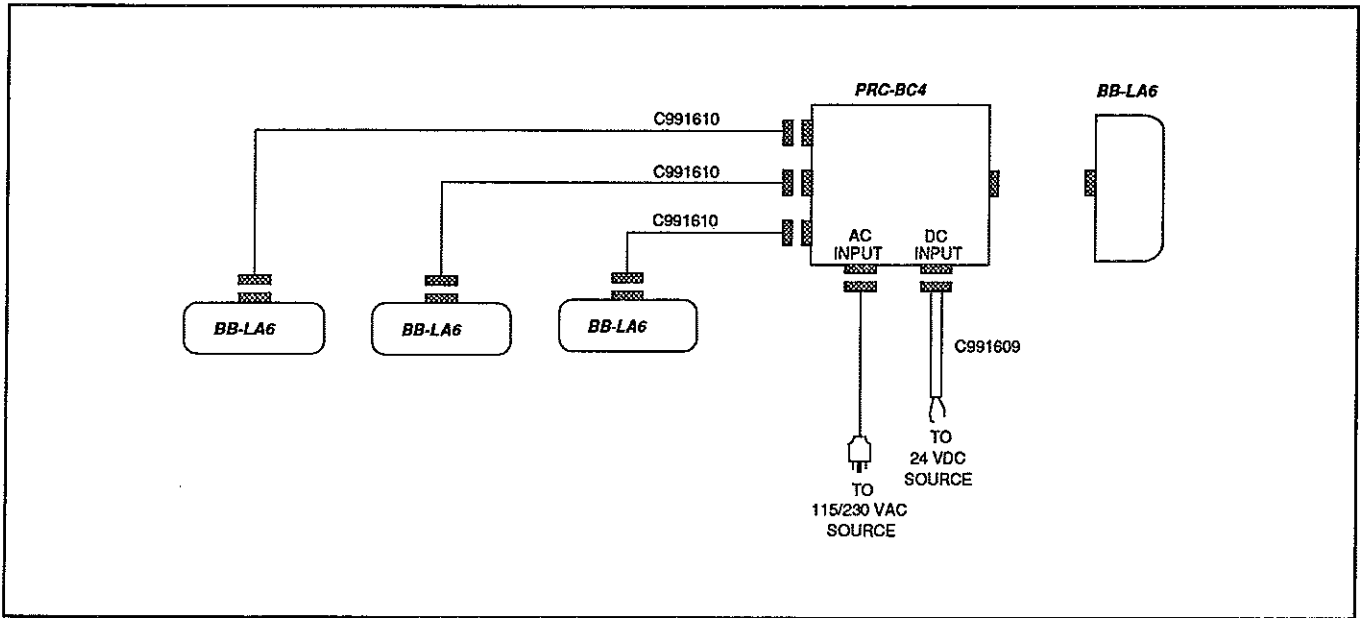

FIGURE B-3.
Operation of PRC-BC4 with Batteries.

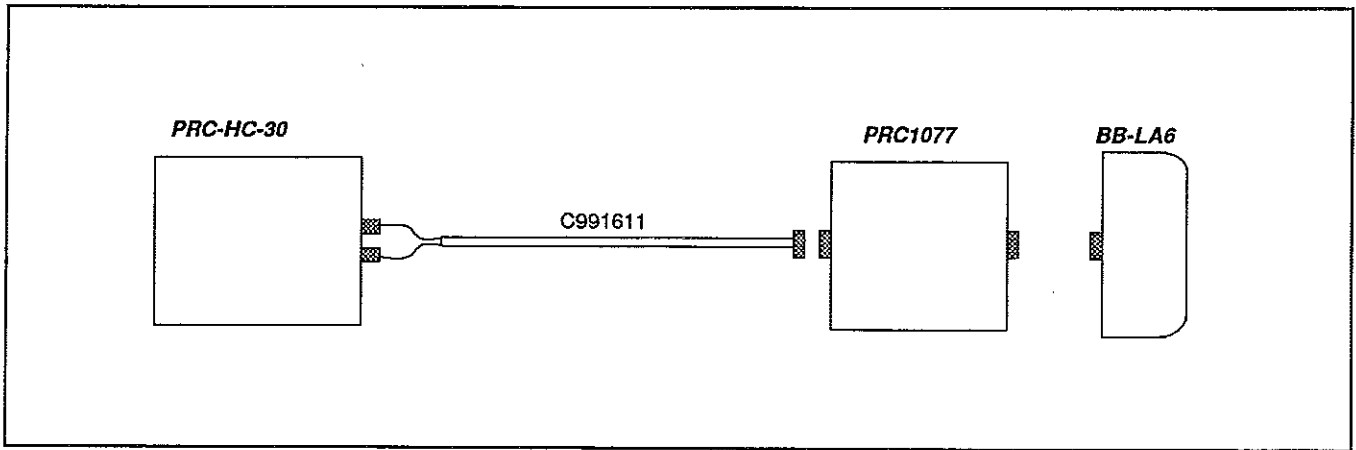

FIGURE B-4.
Battery Charging Using the PRC-HC-30 and PRC1077.

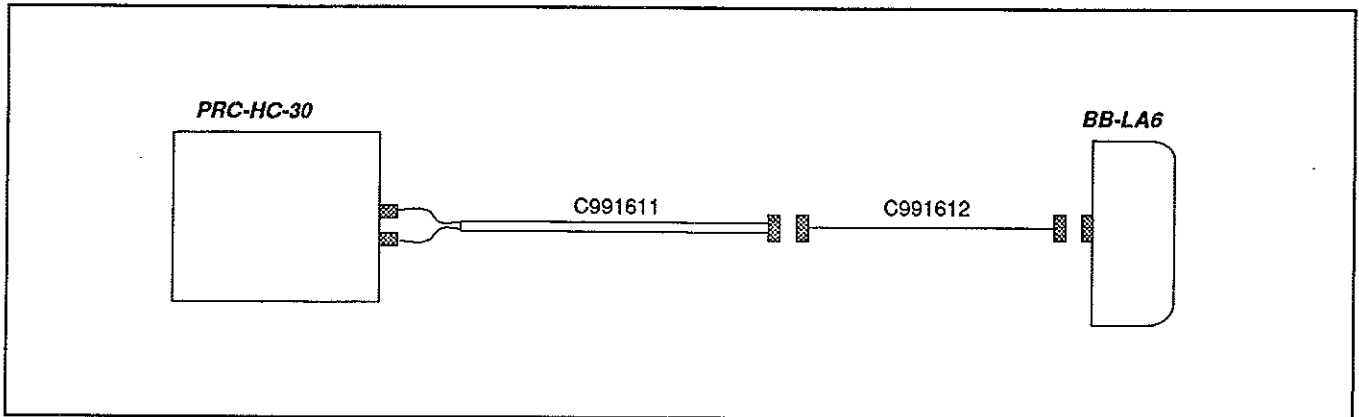

FIGURE B-5.
Battery Charging Using the PRC-HC-30 Directly.

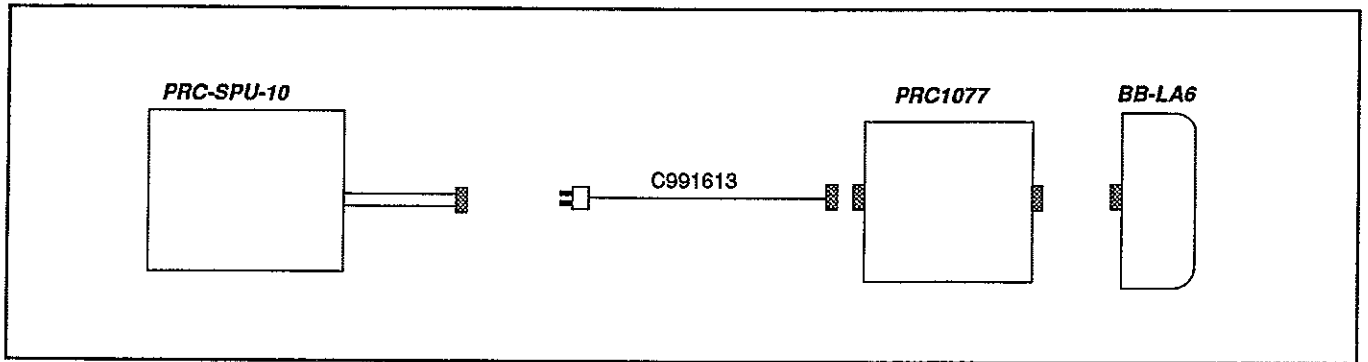

FIGURE B-6.
Battery Charging Using the PRC-SPU-10 and PRC1077.

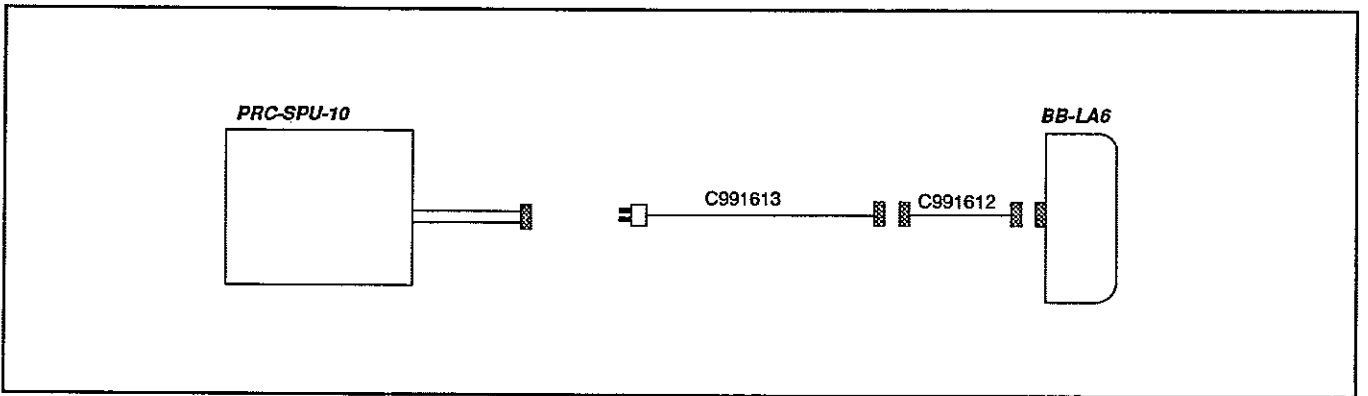

FIGURE B-7.
Battery Charging Using the PRC-SPU-10 Directly.

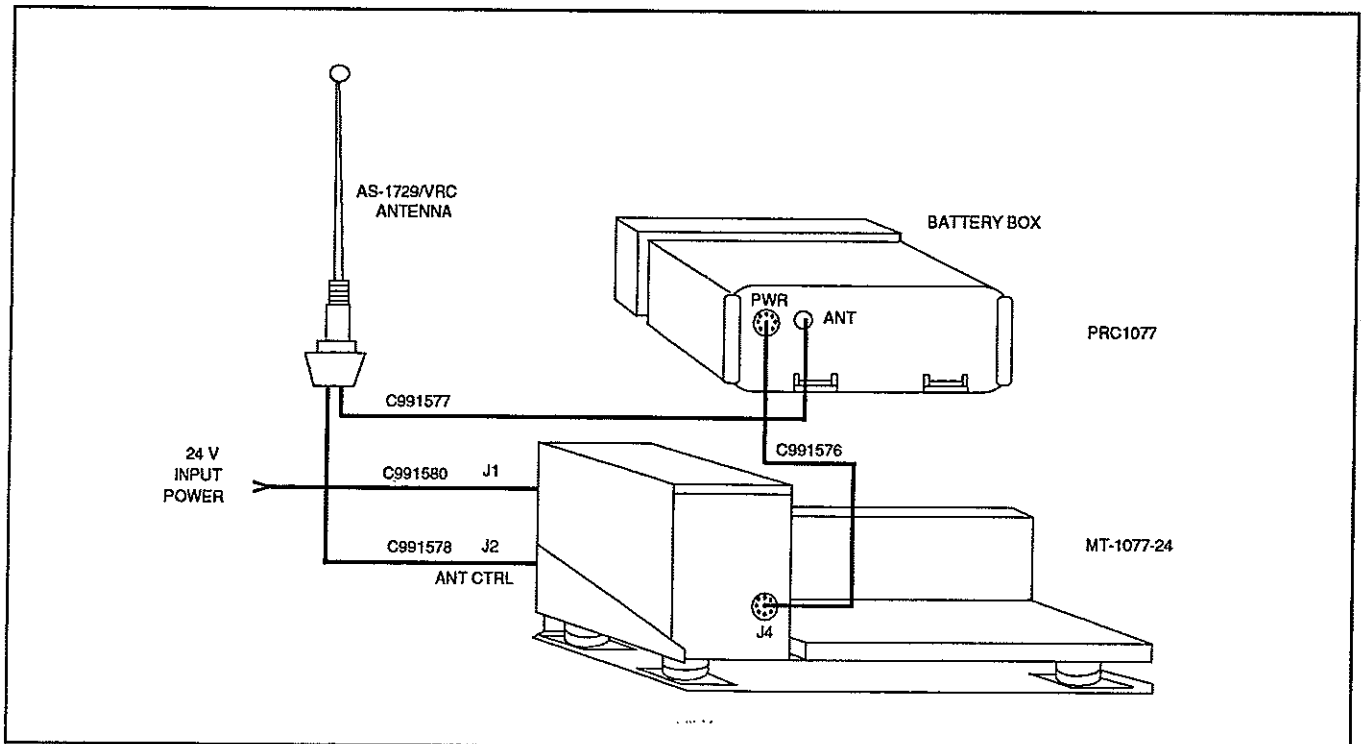

FIGURE B-8.
PRC1077/VRC-64 Mobile 5-W System (24 Vdc).

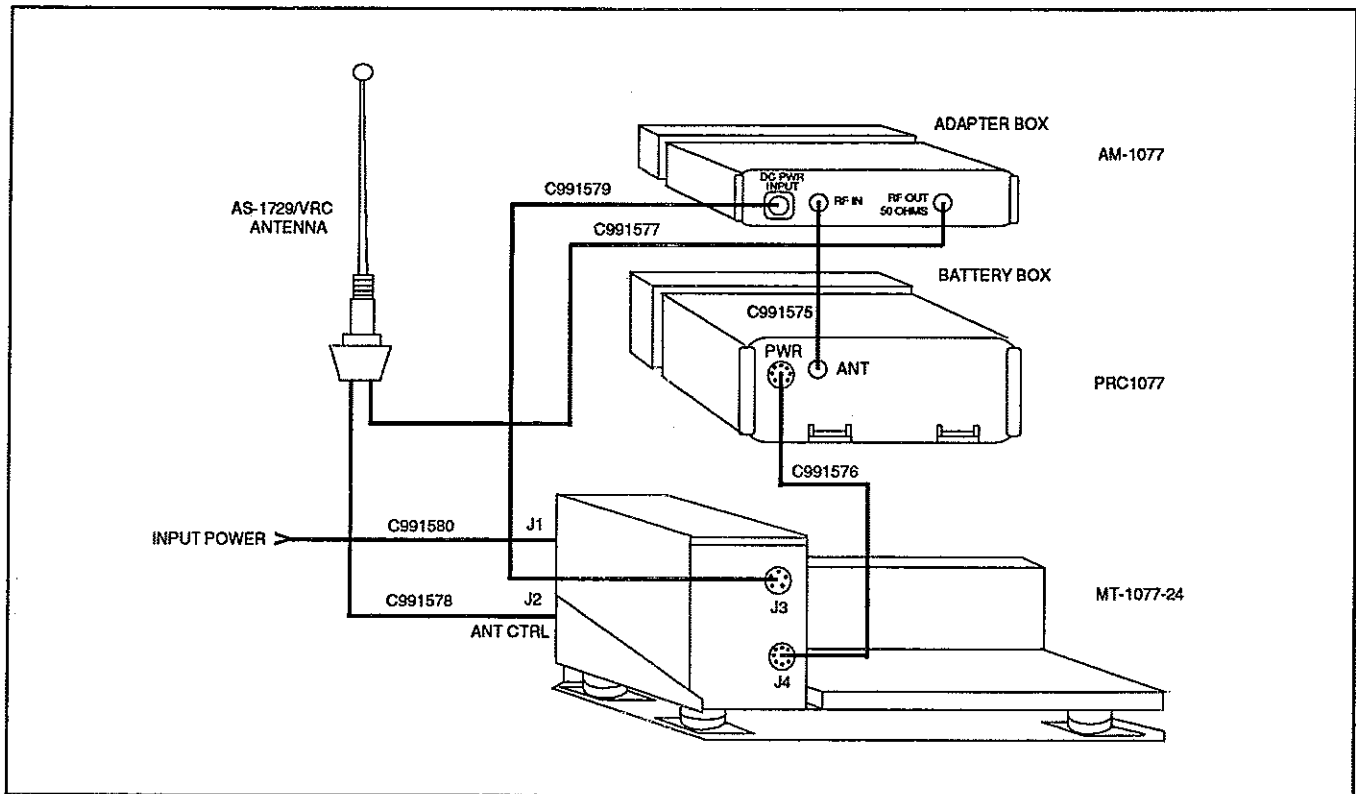

FIGURE B-9.
PRC1077/VRC-46 Mobile 50-W System (24 Vdc)

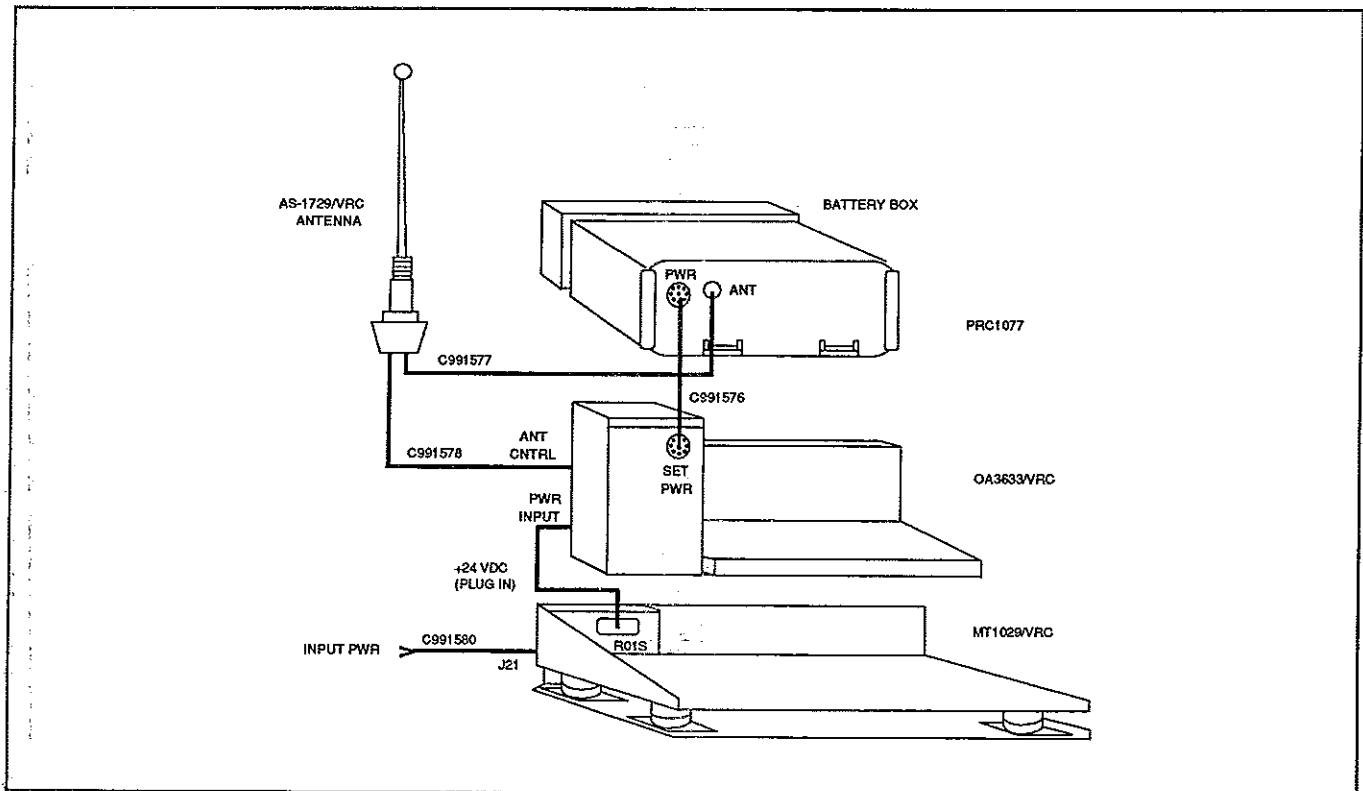

FIGURE B-10.
PRC1077/OA3633/SYS Mobile 5-W System with U.S. Military Mount (24 Vdc).

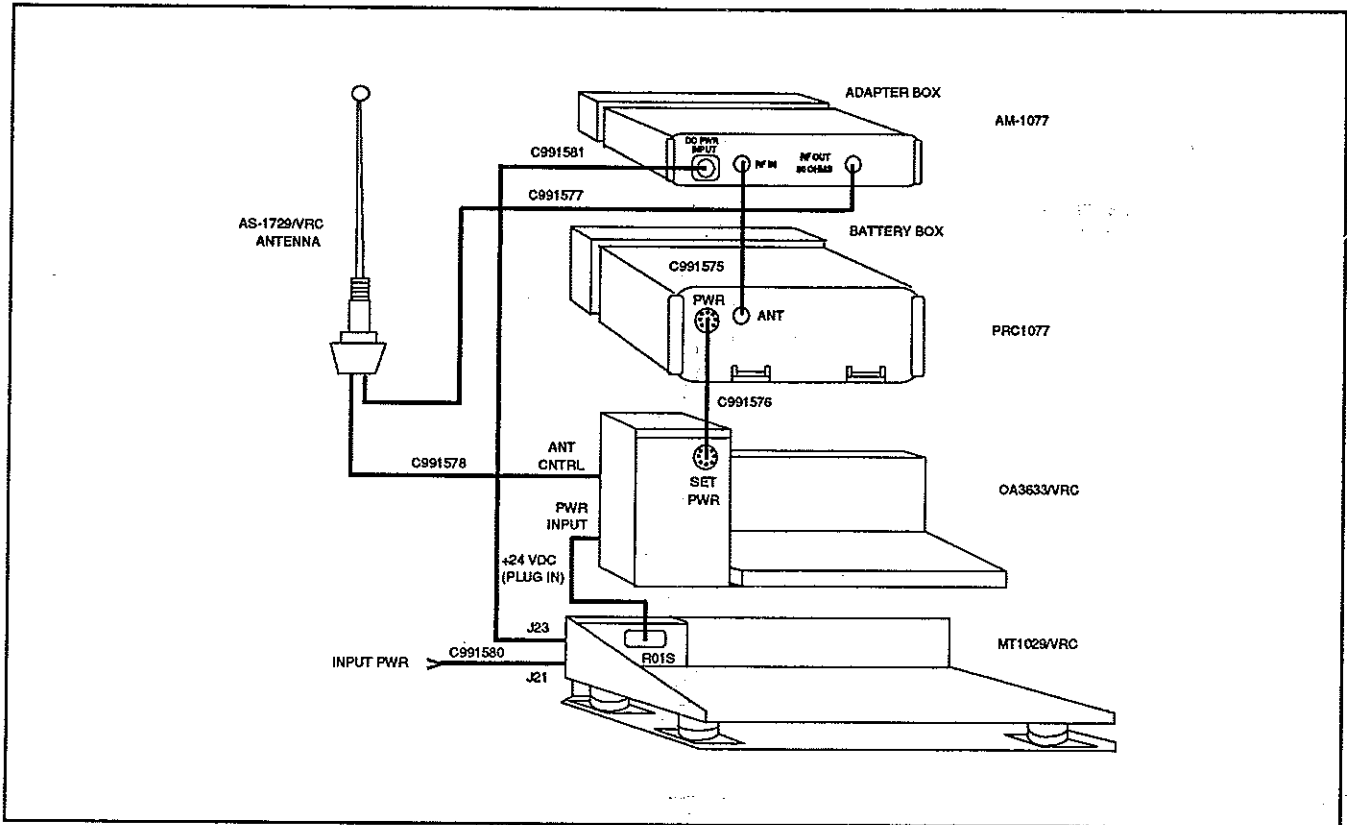

FIGURE B-11.
PRC1077/AM-1077/OA3633/SYS 50-W Mobile System with U.S. Military Mount (24 Vdc).

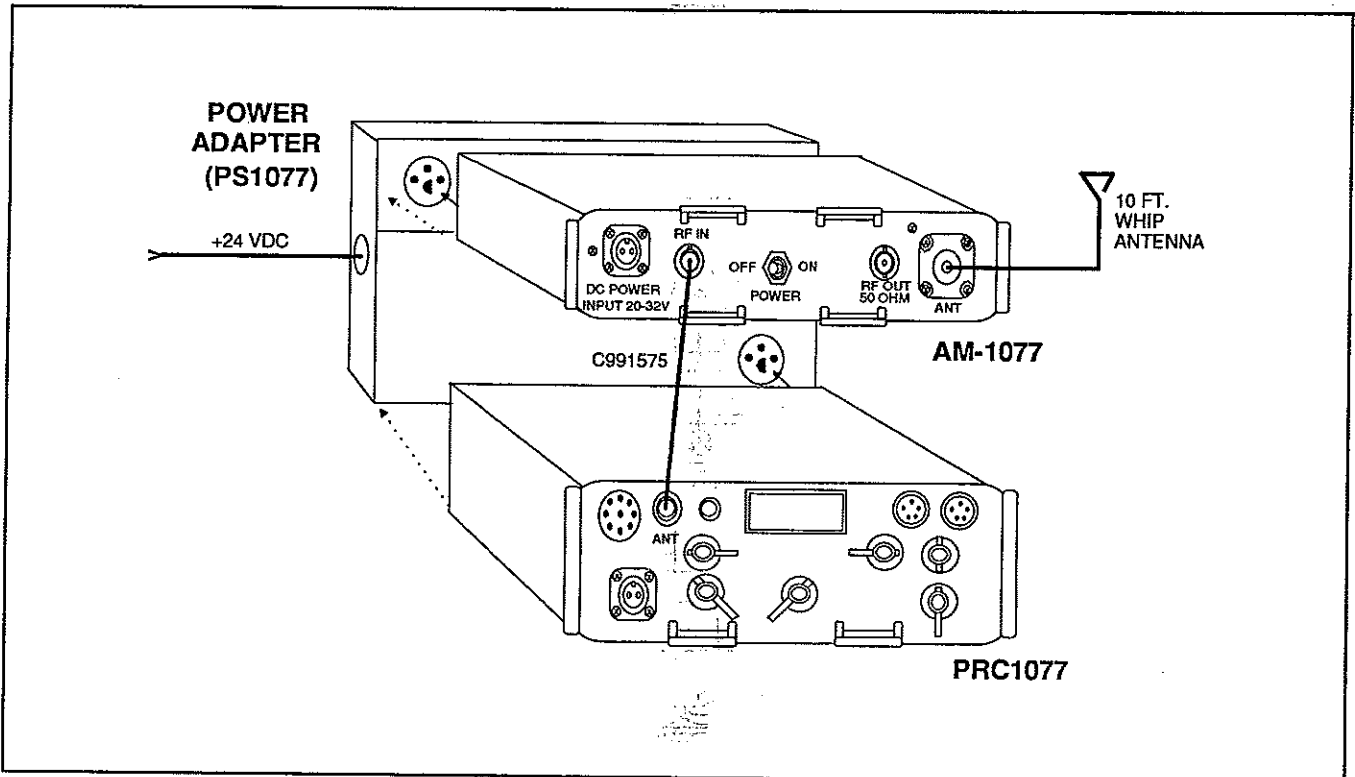
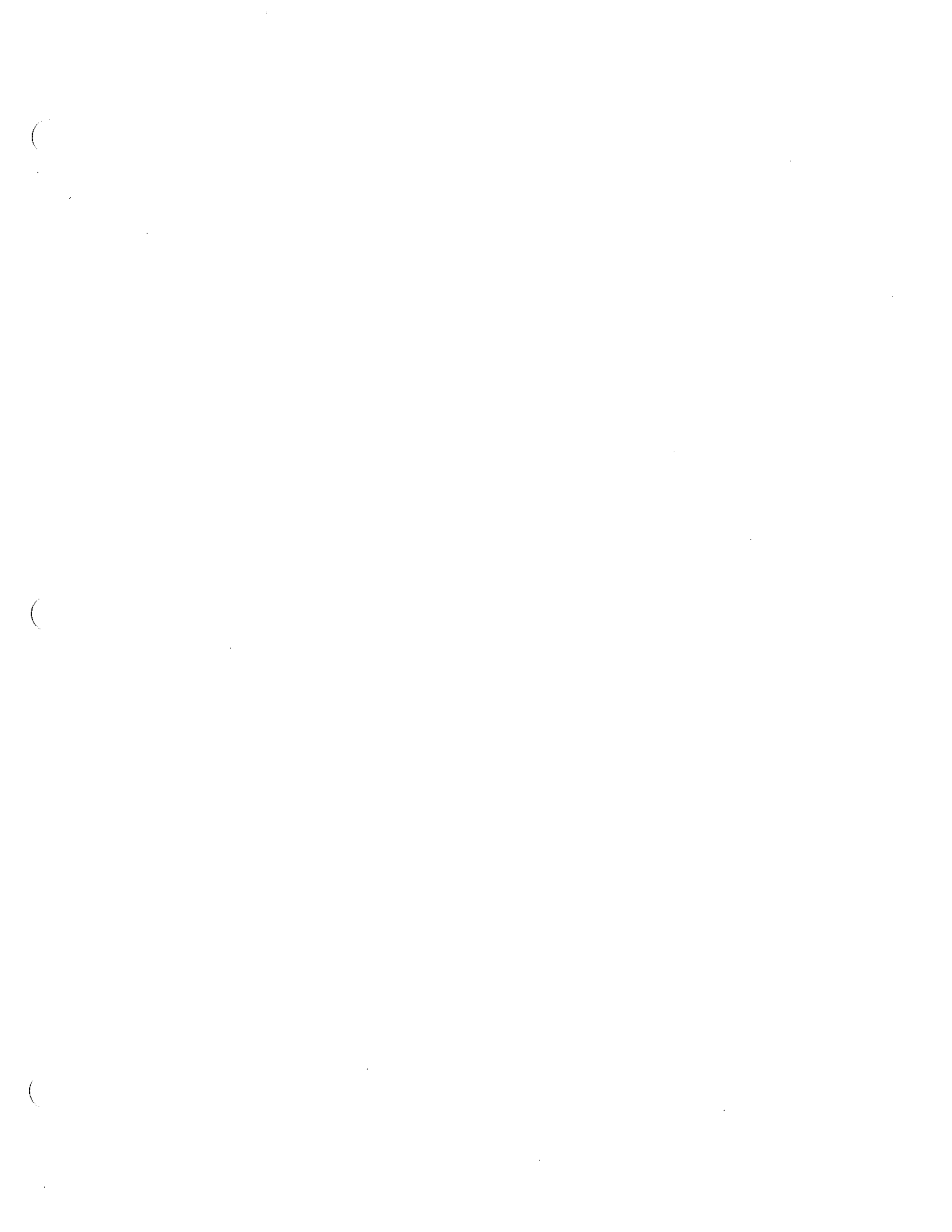

FIGURE B-12.
Mobile/Portable 50-W System (24 Vdc).





()

()

()