

DEPARTMENT OF THE ARMY TECHNICAL MANUAL

DEPARTMENT OF THE AIR FORCE TECHNICAL ORDER

TM 11-806
TO 31R2-2GRC19-11

RADIO TRANSMITTER T-195/GRC-19

TM 11-806/TO 31R2-2GRC19-11—RADIO TRANSMITTER T-195/GRC-19—



DEPARTMENTS OF THE ARMY AND THE AIR FORCE
JUNE 1956

WARNING

DANGEROUS VOLTAGES EXIST IN THIS EQUIPMENT

Be careful when working on the +250-volt plate circuits, and on the 115-volt motor circuits.

EXTREMELY DANGEROUS VOLTAGES EXIST IN THE FOLLOWING UNITS:

Modulator	1,000 volts
Power Amplifier	1,000 volts

DON'T TAKE CHANCES!

TECHNICAL MANUAL }
 No. 11-806 }
 TECHNICAL ORDER }
 No. 31R2-2GRC19-11 }

DEPARTMENTS OF THE ARMY AND
 THE AIR FORCE
 WASHINGTON 25, D. C., 22 June 1956

RADIO TRANSMITTER T-195/GRC-19

	Paragraphs	Page
CHAPTER 1. INTRODUCTION		
Section I. General	1, 2	3
II. Description and data	3-11	3
CHAPTER 2. INSTALLATION		
Section I. Service upon receipt of Radio Transmitter T-195/GRC-19	12-16	9
II. Controls and instruments	17, 18	13
III. Presetting and initial adjustment of equipment	19-21	17
CHAPTER 3. OPERATION		
Section I. Operation under usual conditions	22-24	18
II. Operation under unusual conditions	25-28	20
CHAPTER 4. ORGANIZATIONAL MAINTENANCE		
Section I. Organizational tools and test equipment	29, 30	22
II. Preventive maintenance services	31-34	22
III. Lubrication and weatherproofing	35-37	25
IV. Troubleshooting at organizational maintenance level	38-41	26
CHAPTER 5. AUXILIARY EQUIPMENT	42-48	33
CHAPTER 6. THEORY		
Section I. Introduction	49, 50	40
II. Master oscillator stages	51-54	41
III. Exciter	55-60	43
IV. Power amplifier stages	61-64	49
V. Modulator	65-72	57
VI. Antenna tuning system	73-78	63
VII. Antenna switching and keying circuits	79-81	78
VIII. Autotune system	82-86	81
IX. Power circuits and servo motors	87-93	87
CHAPTER 7. FIELD MAINTENANCE		
Section I. Troubleshooting at field maintenance level	94-107	95
II. Repairs and lubrication	108-112	144
III. Alignment and adjustment procedures	113-125	165
IV. Final testing	126-130	173
CHAPTER 8. SHIPMENT AND LIMITED STORAGE AND DEMOLITION TO PREVENT ENEMY USE		
Section I. Shipment and limited storage	131, 132	177
II. Demolition of materiel to prevent enemy use	133, 134	177
APPENDIX GLOSSARY OF TERMS		185
INDEX		187

* This manual supersedes TM 11-806, 27 April 1954, including C 1, 17 January 1956

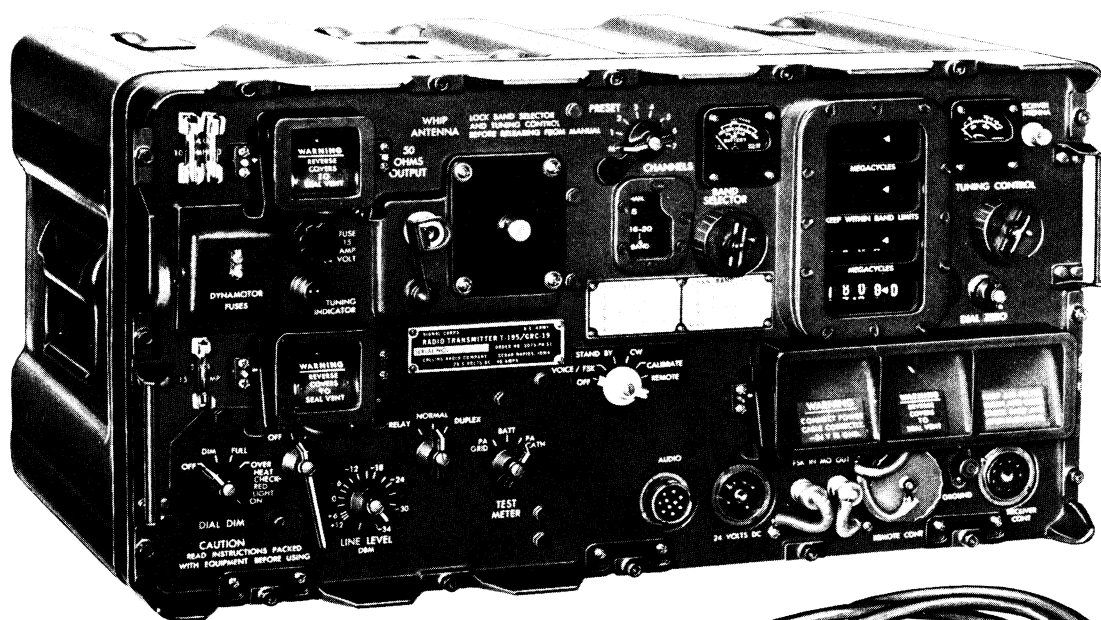

ELECTRICAL SPECIAL
PURPOSE CABLE
ASSEMBLY CX-2583/U

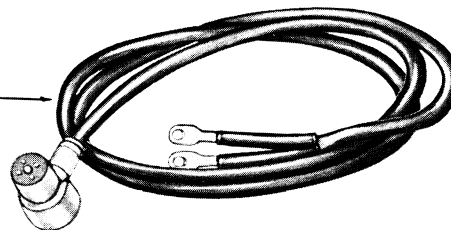

TM 806-1

Figure 1. Radio Transmitter T-195/GRC-19.

CHAPTER 1

INTRODUCTION

Section I. GENERAL

1. Scope

a. This manual contains information for the installation, maintenance, and repair of Radio Transmitter T-195/GRC-19 (fig. 1). Information is provided also for Transmitter Control C-822/GRC-19 (fig. 13). This manual is primarily for maintenance personnel and provides information for the operation of the transmitter as a complete unit alone. For information on the operation of the transmitter as part of a complete system, refer to TM 11-274 for Radio Set AN/GRC-19.

b. To avoid constant use of lengthy nomenclature, terms are applied, throughout this manual, to various items as follows:

Term	Nomenclature
Transmitter.....	Radio Transmitter T-195/GRC-19.
Mount.....	Mounting MT-925/GRC-19.
Remote control unit...	Transmitter Control C-822/GRC-19.
Power cable.....	Electrical Special Purpose Cable Assembly CX-2583/U.
Remote control cable...	Electrical Special Purpose Cable Assembly CX-2585/U.

c. Throughout this manual, *24 volts* is used as the value of the input voltage from the primary power source. This value is used because the

equipment is so marked. Actually, the voltage applied to the equipment from the primary source will be approximately 28.5 volts.

d. Forward comments on this manual direct to the Commanding Officer, Signal Corps Publications Agency, Fort Monmouth, N. J.

2. Forms and Records

a. Unsatisfactory Equipment Reports.

- (1) DA Form 468, Unsatisfactory Equipment Report, will be filled out and forwarded to the Office of the Chief Signal Officer as prescribed in AR 700-38.
- (2) DD Form 535, Unsatisfactory Report, will be filled out and forwarded to Commanding General, Air Materiel Command, Wright-Patterson Air Force Base, Dayton, Ohio, as prescribed in AR 700-38 and AF TO 00-35D-54.

b. Damaged or Improper Shipment Report. DD Form 6, Report of Damaged or Improper Shipment, will be filled out and forwarded as prescribed in AR 700-58 (Army); Navy Shipping Guide, Article 1850-4 (Navy); and AFR 71-4 (Air Force).

c. Preventive Maintenance Form. DA Form 11-239, Second and Third Echelon Maintenance Check List for Signal Corps Equipment (Radio Communication, Direction Finding, Carrier, Radar) will be prepared in accordance with instructions on the back of the form (fig. 11).

Section II. DESCRIPTION AND DATA

3. Purpose

Radio Transmitter T-195/GRC-19 (fig. 1) provides for single-channel transmission of continuous-wave (cw), voice, and frequency-shift-keyed

(fsk) radio signals. The transmitter operates in the range of 1.5 to 20 megacycles (mc), and may be used in fixed or mobile service. The operating components of Radio Transmitter T-195/GRC-19 are listed in the table of components (par. 7).

4. System Application

The transmitter is designed primarily for vehicular installation, and can be used in a radio system for normal, duplex, or relay operation. It is part of Radio Set AN/GRC-19, the major components of which are the transmitter, and Radio Receiver R-392/URR.

a. The block diagram (fig. 2) shows Radio Set AN/GRC-19 connected for cw or voice transmission in normal operation, and using remote control. A 50-ohm unbalanced line is used to connect the transmitter to a fixed antenna, and a whip antenna is used for vehicular installations. As shown in figure 2, audio or cw signals are applied to the transmitter through the remote control unit. In addition, the transmitter can be turned on or off, and channel selection can be made at the remote control location. A set of headphones provides for reception, and for monitoring the transmitted signal. Primary power is obtained from a 24-volt source and is applied to the transmitter. The transmitter and receiver are interconnected so that the transmitter furnishes primary power to the receiver and also controls its

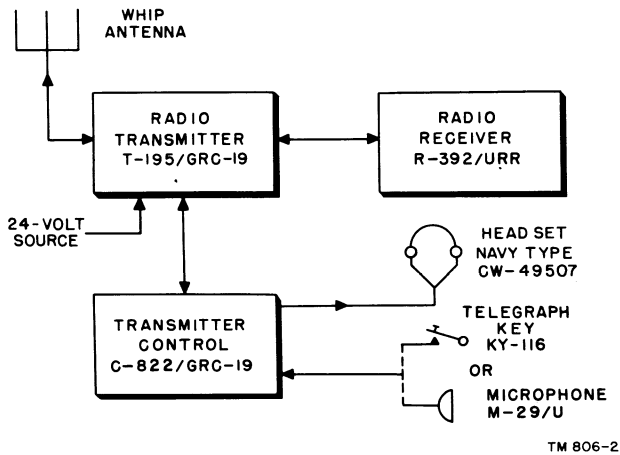

Figure 2. Radio set AN/GRC-19, simplified system block diagram.

antenna and audio output circuits. A common antenna is used; during transmission the antenna is connected to the transmitter, and between transmissions it is connected to the receiver.

b. Radio Set AN/GRC-19 can be used also for relay and duplex operation, in which case separate antennas are used for reception and transmission. The receiver and transmitter then are operated at different frequencies which are separated by at least 1 megacycle.

c. For fsk operation (fig. 3), the transmitter is used with a teletypewriter and an external exciter, Modulator MD-203/GR. The output of the master oscillator (mo) is applied, through the MO OUT receptacle, to Modulator MD-203/GR, and the output of Modulator MD-203/GR is fed to the transmitter exciter through the FSK IN receptacle. When the keys of the teletypewriter are in the marking position, the teletypewriter supplies dc signals to the modulator. These dc signals cause the modulator to shift the mo frequency to a higher value. When the keys of the teletypewriter are in a spacing position, the modulator causes the mo frequency to become lower. The overall result is that the radio frequency (rf) output signal is shifted in accordance with the keying action of the teletypewriter.

5. Technical Characteristics

Frequency range	1.5 to 20 mc (10 bands).
Frequency stability	0.03% plus 1,000 cps from 1.5 to 20 mc.
Method of tuning	Manual or automatic.
Types of operation	Cw, voice, and/or fsk.
Reset accuracy of preset channels.	Within 0.005% or 500 cycles, whichever is greater.
Reliable distance range	50 miles.
Types of antenna	50-ohm unbalanced antenna, 15-foot whip, or transformer-fed doublet.
Radiated power with 50-ohm antenna or transformer-fed doublet.	1.5 to 12.0 mc—100 w. 12.0 to 16.0 mc— 90 w. 16.0 to 20 mc— 80 w.

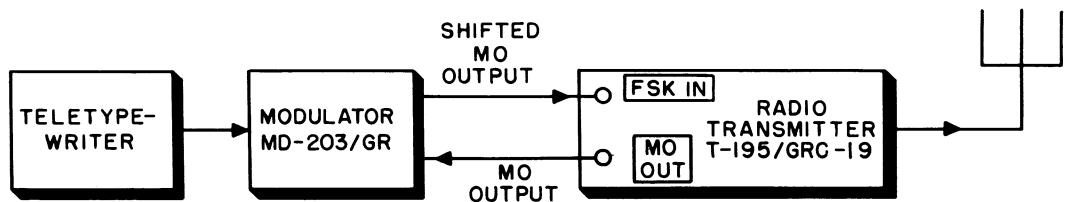

Figure 3. Frequency-shift, single-channel radioteletype system, simplified block diagram.

Radiated power with 15-foot whip antenna.	1.5 to 2.0 mc— 13 w. 2.0 to 3.0 mc— 28 w. 3.0 to 4.0 mc— 45 w. 4.0 to 5.0 mc— 60 w. 5.0 to 6.0 mc— 90 w. 6.0 to 9.0 mc— 100 w. 9.0 to 16.0 mc— 90 w. 16.0 to 20.0 mc— 80 w.
Spurious radiation (excluding harmonics).	At least 60 db below level of desired transmitted signal.
Harmonic radiation	At least 40 db below level of desired transmitted signal.
Audio input circuits	Microphone, or 600-ohm line.
Audio level control:	
Microphone	Audio level meter and modulator gain control to adjust transmitter for 100% modulation.
600-ohm line	Audio level meter and line level control to adjust transmitter for 100% modulation from any fixed input level in the range of +12 dbm to -34 dbm.
Audio distortion	Less than 10% at 95% modulation.
Monitoring provisions	10 mw of audio is available for monitoring cw and voice signals; 400-cycle sidetone signal provided in cw service.
Metering provisions	Pa cathode current, pa grid current, battery voltage, and modulation level.
System application	Normal, relay, and duplex.
Remote control facilities	Keying control and audio input. Control of frequency and type of operation, using Transmitter Control C-822/GRC-19.

Primary input voltage	22 to 30 volts dc. (For best results, use 28.5 volts.)
Maximum primary current drain.	42 amperes.
Standby primary current drain.	9 amperes.
Number of tubes	22.

6. Packaging Data

(fig. 4)

When Radio Transmitter T-195/GRC-19 is packed for export or domestic shipment, a sheet of neutral paper (paper which does not contain sulphur) and a Parapad (fiber-composition board) are placed on each of two sides. The transmitter with Parapads is then fitted into a corrugated fiberboard carton which is then taped. The carton is placed in a wooden crate and secured at the corners by inserting wooden cleats. In the space between the carton and the wooden crate, between the cleats, a manual contained within a sealed pouch is stored. The lid is nailed to the crate at 2-inch staggered intervals, and secured with steel straps. For further security, the straps are stapled. The complete package is 14 inches high by 17½ inches wide by 29½ inches long, giving it a volume of approximately 5.2 cubic feet and a gross weight of 160 pounds. An exploded view of the packaging for Radio Transmitter T-195/GRC-19 is shown in figure 4. The running spares and power cable for the transmitter are shipped in a separate, paper-wrapped, corrugated fiberboard carton. The mount, if ordered, is shipped in a separate wooden crate.

Note. Items may be packaged in a manner different from that shown, depending on the supply channel.

7. Table of Components

Component	Quantity	Height (in.)	Depth (in.)	Length (in.)	Volume (cu. ft.)	Weight (lb.)
Radio Transmitter T-195/GRC-19	1	11½	14¾	22	3.5	122
Electrical Special Purpose Cable Assembly CX-2583/U	1			120		2½
Case CY-1451/GRC-19	1					1
Set of spare tubes	1 (19)	}				3¼
Set of spare fuses	1 (18)					
Set of spare lamps	1 (2)					

Note. This list is for general information only. See appropriate publications for information pertaining to the requisition of spare parts.

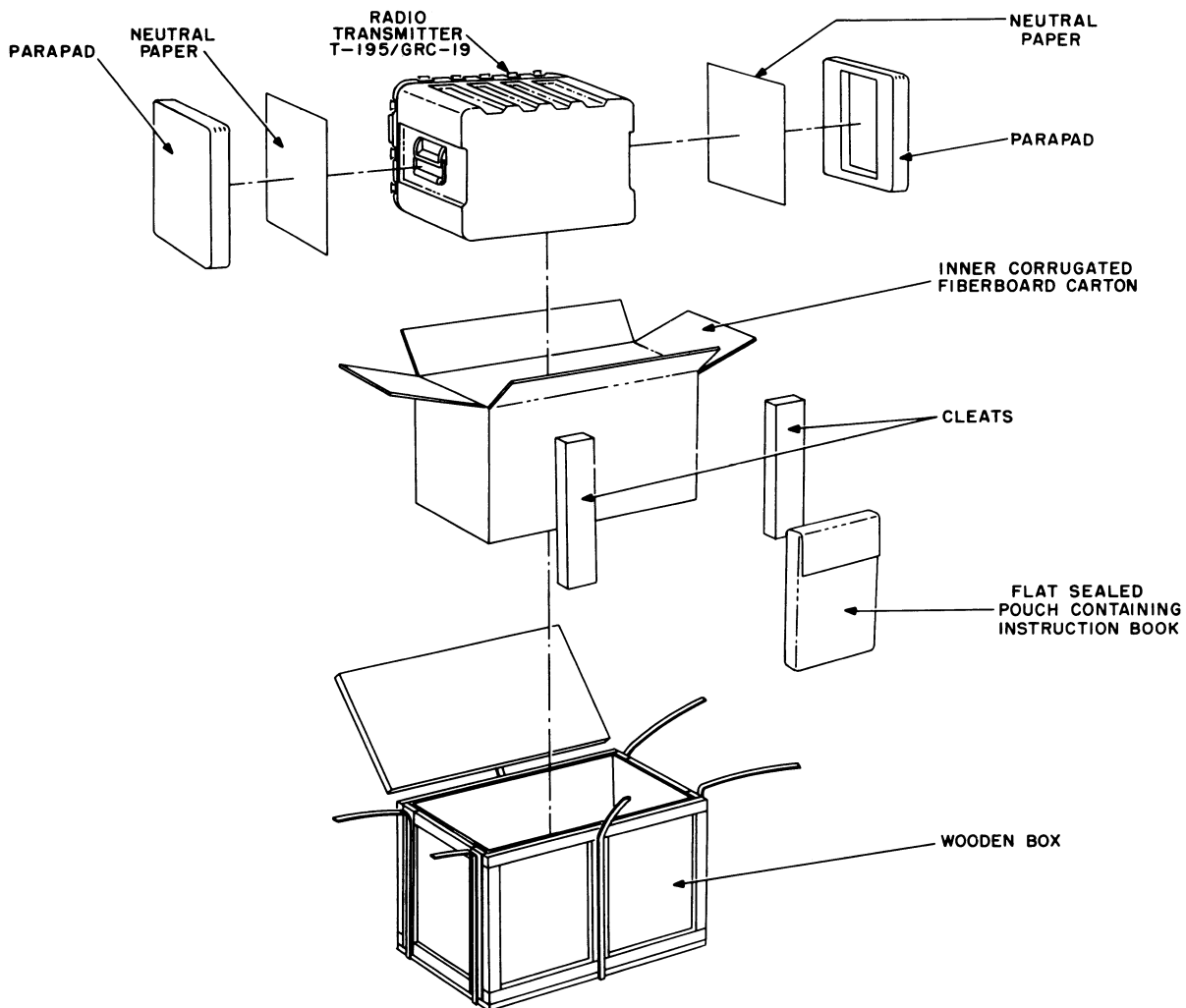

TM 806-4

Figure 4. Radio Transmitter T-195/GRC-19, packing and packaging.

8. Description of Radio Transmitter T-195/GRC-19

(figs. 1, 5, and 6)

a. The transmitter is of ruggedized construction, and has provisions for waterproofing during transport or storage. Air intake and exhaust vents are used in the forced-air cooling system, and these vents can be closed, thus making the transmitter waterproof.

Caution: The transmitter cannot be operated with the intake and exhaust vents closed. Before operation, make sure that the vents are open, or damage to the equipment may result.

b. The internal parts of the transmitter con-

sist of eight removable subchassis, which in addition to various relays, switches and subassemblies, are mounted onto the main frame. All operating controls and receptacles are mounted on the front panel, which is fastened to the main frame. Two handles (one at each end of the panel) facilitate removal of the transmitter from the case, and a handle at each end of the case is provided for carrying.

c. The transmitter operating frequency can be selected manually, or by an electromechanical channel selection system. The electromechanical system, known as Autotune, automatically adjusts tuning elements in the transmitter to provide a preset operating frequency. Eight Auto-

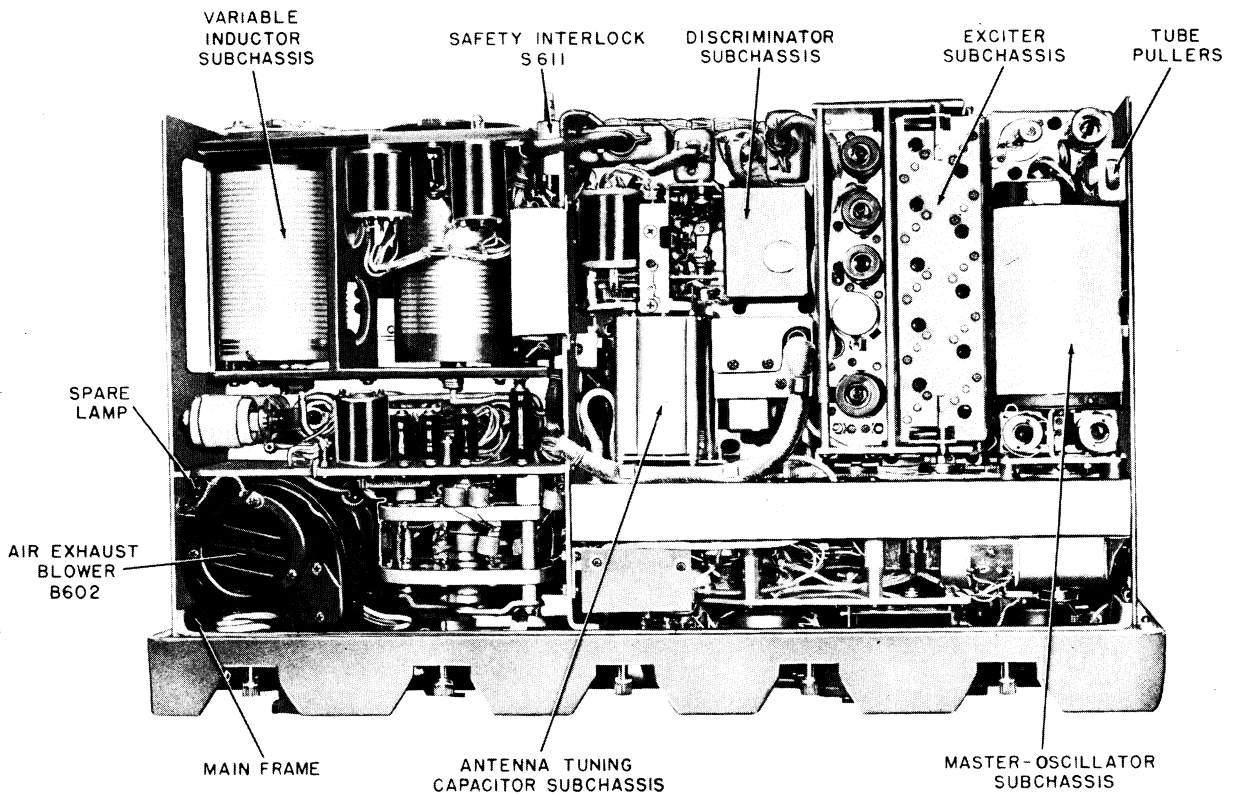

TM 806-5

Figure 5. Radio Transmitter T-195/GRC-19, top view, case removed.

tune channels are available, one of which is designated for manual tuning. Each channel is preset by the operator to a desired channel frequency, after which it is only necessary to adjust a present channel switch to obtain a desired operating frequency.

d. Automatic antenna tuning is provided by the antenna tuning system, so that no tuning by the operator is required. In general, antenna tuning is referred to (throughout this manual) as automatic tuning, which is not to be confused with the Autotune system (channel selection).

9. Description of Electrical Special Purpose Cable Assembly CX-2583/U

This cable (fig. 1) connects the transmitter to the 24-volt power supply. It consists of 10 feet of standard CO-212 cable terminated at one end with $\frac{3}{8}$ -inch lugs and at the other end with an Amphenol type 164-42 FS 4-contact plug. Standard CO-212 cable is a concentric 2-conductor

cable consisting of one No. 8 AWG center conductor and an equivalent No. 8 shield.

10. Running Spares

A group of running spares is furnished with each transmitter. Spares are provided for all normally expendable items such as tubes, dial lamps, and fuses. The following is a list of running spares:

- 2 tubes, type 4X150D
- 1 tube, type 5726
- 3 tubes, type 5749
- 2 tubes, type 5751
- 1 tube, type 5763
- 1 tube, type 5814
- 2 tubes, type 6005
- 2 tubes, type 6AK6
- 1 tube, type 6AU6WA
- 3 tubes, type 12AT7
- 1 tube, type OA2
- 2 dial lamps, 28 v, 0.175 amp
- 6 fuses, 10 amp
- 6 fuses, 15 amp
- 6 fuses, 30 amp

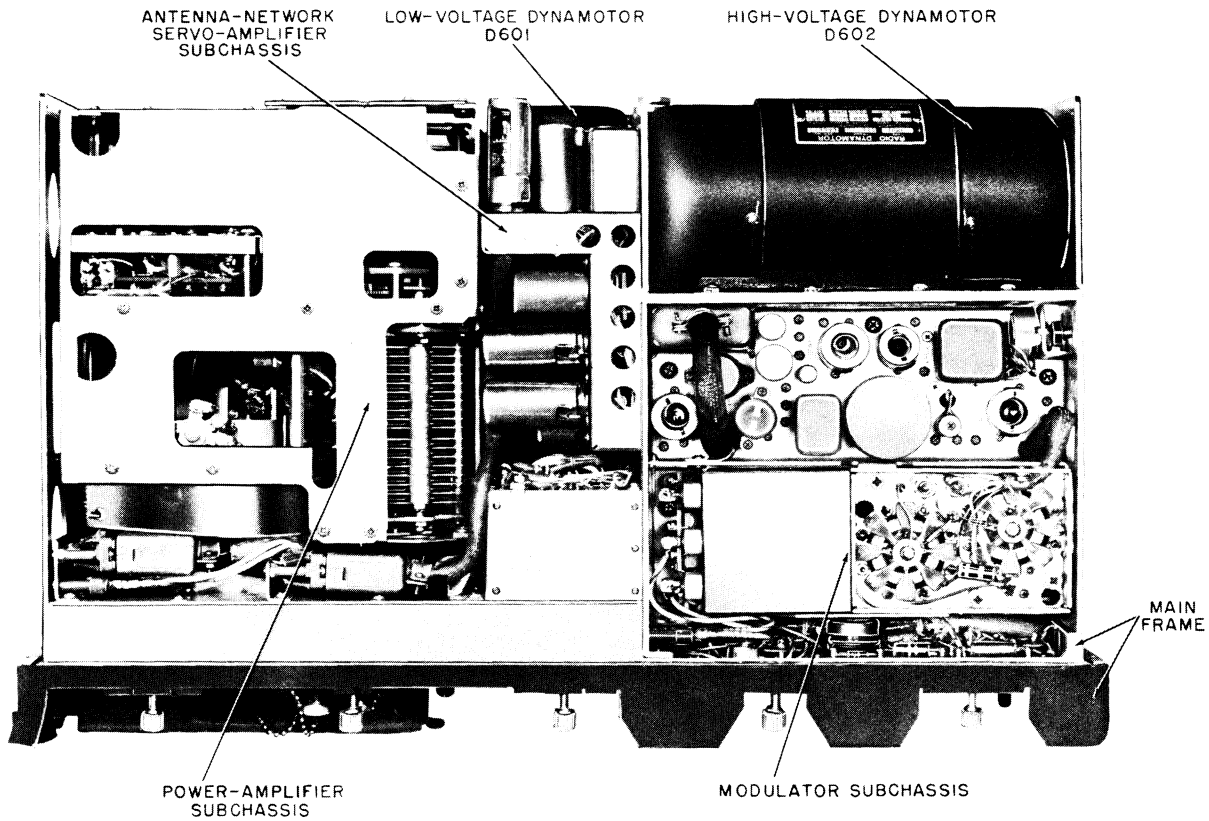

TM 806-6

Figure 6. Radio Transmitter T-195/GRC-19, bottom view, case removed

11. Additional Equipment Required

The following material is *not* supplied as part of Radio Transmitter T-195/GRC-19, but is required for its operation:

- Generator (par. 5)
- Antenna (refer to TM 11-274, Radio Set AN/GRC-19)
- Telegraph Key KY-116/U or equivalent
- Microphone M-29/U or equivalent

Headset Navy type CW-49507 or equivalent
600-ohm headset.

Electrical Special Purpose Cable Assembly
CX-1852/U or equivalent

Headset Cord CX-1334/U or equivalent
Grounding cable.

Note. Handset H-33/PT can be substituted wherever
Microphone M-29/U or Headset Navy Type CW-49507 is
required.

CHAPTER 2

INSTALLATION

Section 1. SERVICE UPON RECEIPT OF RADIO TRANSMITTER T-195/GRC-19

12. Siting

(fig. 7)

Radio Transmitter T-195/GRC-19 can be used in a mobile or fixed station installation.

a. For mobile operation, it is desirable to locate the vehicle away from obstructions such as bridges, power lines, or trees. A position which extends the horizon, or line of sight, usually will improve transmission range.

b. For a fixed station installation, requirements are as follows:

- (1) The shelter should be dry, and within the ambient temperature range of -40° C. to 65° C. (40° F.- 149° F.).
- (2) Sufficient space must be available for removing the transmitter from its case for repair work.
- (3) Adequate lighting for day and night operation must be provided. The transmitter should be positioned so that the panel designations may be read easily by the operator. Artificial lighting should be provided, with the electric lamps placed so that the light falls directly upon the panel. A portable drop lamp and extension cord should be available for operating and maintenance personnel.
- (4) The shelter should be soundproof as far as possible to reduce mechanical noise.
- (5) Regardless of the type of installation or conditions of operation, special attention should be given to grounding the transmitter to safeguard equipment and personnel.
- (6) Sufficient ventilation should be provided to prevent overheating of the equipment.
- (7) The antenna should be located at an elevated position, and away from obstructions and other antennas.

13. Uncrating, Unpacking, and Checking New Equipment

Note. For used or reconditioned equipment, refer to paragraph 16.

a. General. The equipment is packed identically for both export and domestic shipment. When new equipment is received, select a site where the equipment can be unpacked without exposure to the elements and which is convenient for the installation of the equipment.

Caution: Be careful when uncrating, unpacking, and handling the equipment. If it becomes damaged, a complete overhaul may be required, or the equipment might be rendered useless.

b. Uncrating and Unpacking Export and Domestic Shipments (fig. 4).

- (1) Place the packing crate as near the operating position as convenient.
- (2) Cut and fold back the metal straps.
- (3) Remove nails with a nail puller. Remove the top of the wooden shipping crate. Do not attempt to pry off the top. This procedure may damage the equipment.
- (4) Remove the sealed pouch containing the manual and pull out the wooden cleats that are placed in the corners of the crate.
- (5) Carefully move the crate on its side and pull out the sealed, corrugated fiberboard carton.
- (6) Open the carton and remove the Parapads and paper; then grasp the transmitter by its two carrying handles, withdraw it from the carton, and place it on a work bench or near its final location.

c. Checking.

- (1) Check the contents of the carton against the master packing slip.

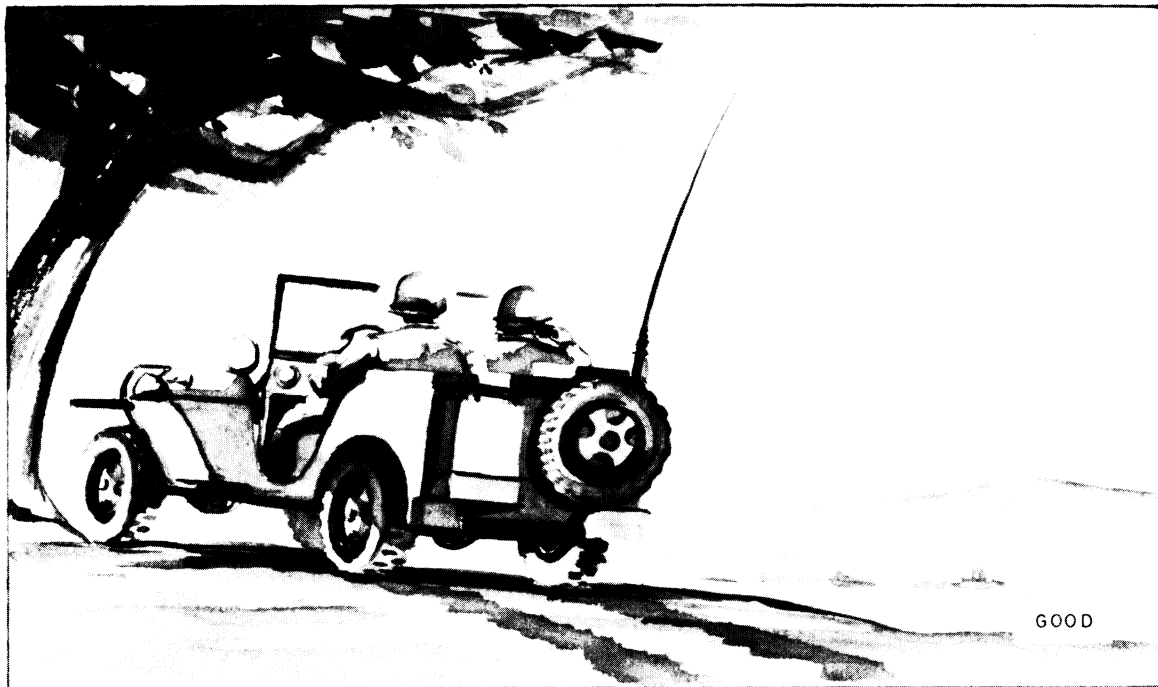
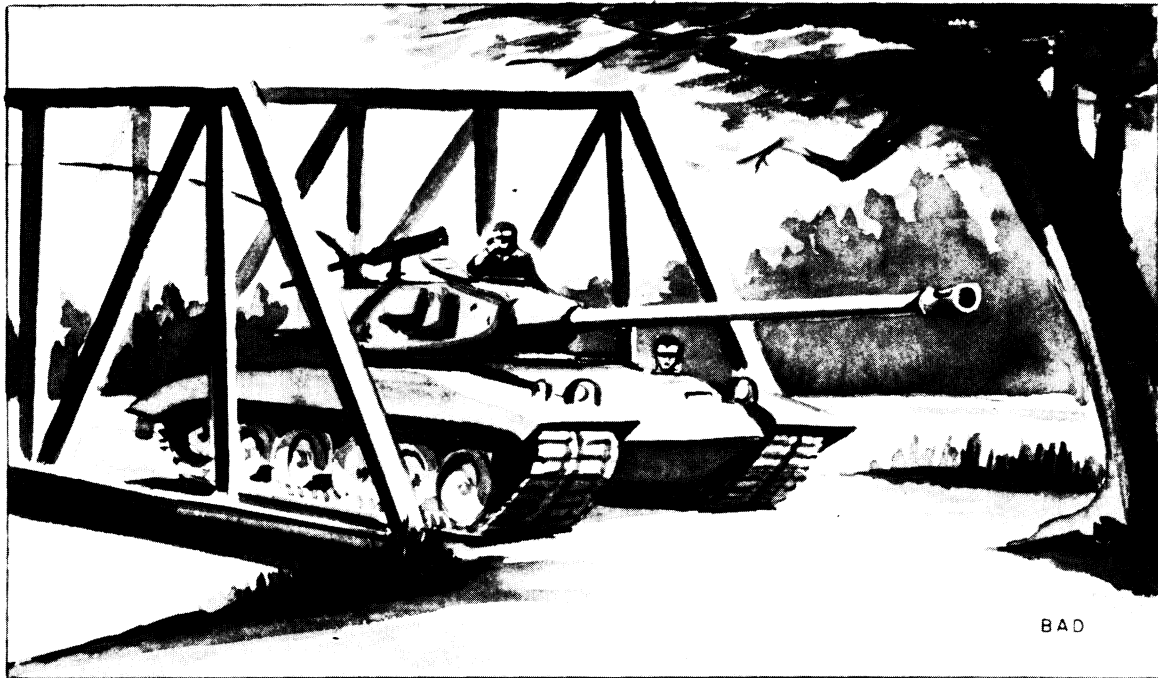

TM 806-8

Figure 7. Siting Radio Transmitter T-195/GRC-19.

- (2) Inspect the front panel of the transmitter for damage to knobs or to glass windows of meters and indicators.
- (3) Make a written record of both front panel Autotune control positions by reference to the frequency indicator. Unlock the Autotune controls. The Autotune mechanisms that operate the TUNING CONTROL and BAND SELECTOR control are unlocked by turning their respective locking keys approximately 2 revolutions counterclockwise. Check the mechanical operation of the Autotune mechanism by rotating each control to test smoothness of movement. Any binding or jamming indicates abnormal mechanical operation. Reset each channel to the frequency indicated on the written record and lock the Autotune mechanisms. The mechanisms are locked by turning the locking keys clockwise until they become tight, without undue force. Do not force the controls to rotate. If they do not turn easily, examine them for bent parts or other damage.
- (4) Rotate the BAND SELECTOR control knob until the band-channel dial rotates from 1.5-1.7 to 16-20.
- (5) With the BAND SELECTOR positioned in the 1.5 to 1.7 mc range, rotate the TUNING CONTROL knob until the frequency-indicator counter mechanism rotates from 1,500 kc through 3,000 kc.
- (6) Turn the PRESET CHANNELS switch through each position; note whether it turns freely. Return the switch to its original position. Note that the reminder spring just below and to the left of this switch must be depressed in order to rotate the switch from the M position.
- (7) Return the Autotune controls to the settings recorded as directed in (3) above, and tighten the locking keys. Both Autotune locking keys must be locked before the power is turned on or the position of the PRESET CHANNELS switch is changed. The frequency settings would be lost if the controls were allowed to rotate with the locking keys loose.
- (8) Loosen the 16 Allen head screws on the front panel. Grasp the two handles on the front panel and carefully pull the main frame from the case.
- (9) Inspect the subchassis on upper and lower decks of the transmitter for loose tube shields and broken tubes. See that all connectors are firmly seated; loose connectors are a common cause of improper operation in radio equipment.
- (10) Remove the fuses F601, F602, and F603 (fig. 9) on the front panel and check to see that they are of the proper ratings. Make sure that these fuses are firmly re-seated in their clips. Check to see that the three spare fuses (fig. 9) of proper ratings are in place.

Caution: To avoid serious damage to the transmitter, do not use any fuse rated above the value specified.
- (11) Inspect the equipment for bent or broken connectors and terminals on the front panel. Check to see that all special tools are in place in their holders.
- (12) Lift up the catch on each side of the intake blower cover on the front panel, move the cover to one side, pull out the air filter (fig. 102), and check its condition. Paragraph 34a(12) outlines the method of cleaning this filter.
- (13) Check the contents of the box which contains the power cable and running spares for damaged parts.

14. Installation of Radio Transmitter T-195/GRC-19

Radio Transmitter T-195/GRC-19 is shipped with all tubes and fuses in place. No further internal installation is required. For vehicular installation, instructions are contained in the applicable vehicular installation unit. The type of vehicle determines which installation unit is supplied (or must be requisitioned).

a. Power Supply. A separate power supply is required for the transmitter. For vehicular installation, the generator and complete mounting and power cabling instructions are contained in the applicable vehicular installation unit.

b. Mounting the Transmitter. When the transmitter is installed in a vehicle, Mounting MT-925/GRC-19 (fig. 19) is used. When the transmitter is mounted together with Radio Receiver R-392/URR, as part of Radio Set AN/GRC-19, Mounting MT-851/GRC-19 is used. Mounting hardware as well as instructions are included in the vehicular installation unit. In a fixed-portable installation, the mount is placed on a solid flat surface, large enough to accommodate the mount. For fixed-portable installation, available mounting hardware is used. Be sure that a good contact is made between the mount and the vehicle frame, and between the mount and the transmitter case. If necessary, scrape paint away to provide a good contact for a suitable ground. The transmitter is secured to the mount as follows:

- (1) Release the three retaining clamps on the front of the mount by turning their thumbscrews counterclockwise.
- (2) Slide the transmitter onto the left-hand side of the mount so that the lower rear edge of the transmitter case engages the four hooks at the rear of the mount.
- (3) Place the three retaining clamps so that they will engage with the plates on the lower-front edge of the transmitter case, and tighten the thumbscrews.

c. Antenna Installation. Antenna installation is described in detail in the installation instructions included with the installation kit.

15. Connections

(fig. 8)

Connections to Radio Transmitter T-195/GRC-19 will vary in accordance with the system application. Minimum connections for putting the transmitter into operation are indicated in *a* through *e* below. The cording diagram (fig. 8) indicates the use of all necessary cable connections.

Warning: Voltages dangerous to life are used in this equipment. If the transmitter is not installed on its mount in a vehicle, see that proper ground connections (*c* below) are established before applying power to the equipment.

a. Power Input (fig. 8). Connect the Amphenoltype connector of power cable to the 24 VOLTS DC receptacle (J605) on the transmitter. Connect the two lugs at the other end of the power cable to the 24-volt, direct-current (dc) source. Connect the center lead of the power cable to the

positive terminal, and the shield to the negative terminal of the generator.

Note. This equipment will not operate when connected to power source with improper polarity.

b. Antenna (fig. 8). A whip antenna can be connected to the WHIP ANTENNA receptacle or a 52-ohm transmission line can be connected to the 50 OHMS OUTPUT receptacle. Both antenna systems must not be used at the same time.

- (1) *WHIP ANTENNA receptacle.* When a whip antenna is used, connect the lead-in wire to WHIP ANTENNA terminal J615. The lead-in wire must be capable of operation without voltage breakdown at voltages up to 15,000 volts. Do not use a longer length than is necessary.
- (2) *50 OHMS OUTPUT receptacle.* When an unbalanced 52-ohm antenna system, such as Antenna Group AN/GRA-12, is used, push the cover arm on 50 OHMS OUTPUT connector J614 aside, and connect the transmission line terminated in a UG-21B/U connector to the 50 OHMS OUTPUT connector.

c. Ground Connections (fig. 8). To provide a ground other than the one provided by the mount, connect a ground lead between the post marked GROUND, located at the lower right-hand corner of the transmitter front panel, and a suitable ground. Ground interconnections between the transmitter and companion equipments also should be made.

d. Accessory Connection (fig. 8). Connection is made to AUDIO receptacle J603 for either voice or cw operation as follows:

- (1) *Voice operation.* Connect Microphone M-29/U or its equivalent to AUDIO receptacle J603 with the cable connector supplied with the microphone.
- (2) *CW operation.* Connect Electrical Special Purpose Cable Assembly CX-1852/U between AUDIO receptacle J603 and Telegraph Key KY-116/U or its equivalent.

e. Remote Connection (fig. 8). Connect the remote control cable (fig. 15) between REMOTE CONT receptacle J601 and receptacle J701 (fig. 14) of Transmitter Control C-822/GRC-19 when remote operation of the transmitter is required. Connect audio accessory to the remote control unit.

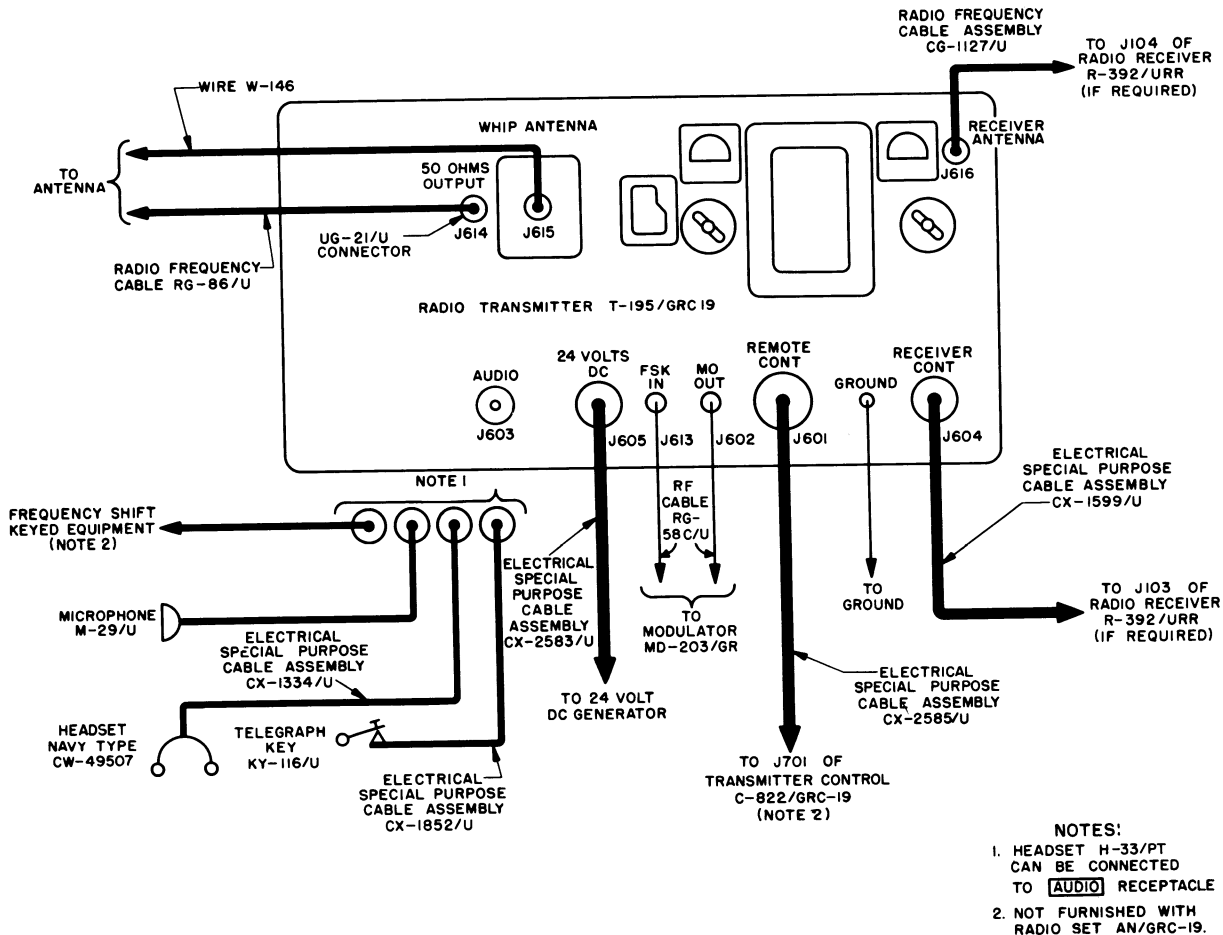

TM806-10

Figure 8. Radio Transmitter T-195/GRC-19, cording diagram.

16. Service Upon Receipt of Used or Reconditioned Equipment

- Follow the instructions in paragraph 13 for uncrating, unpacking, and inspecting the equipment.
- Examine the used or reconditioned equipment for tags or other indications pertaining to changes

in the wiring of the equipment. If any changes in wiring have been made, note the change in this manual, preferably on the schematic diagram.

- Check the BAND SELECTOR and TUNING CONTROL knobs for ease of rotation.
- Perform the installation and connection procedures given in paragraphs 14 and 15.

Section II. CONTROLS AND INSTRUMENTS

17. General

Haphazard operation or improper setting of the controls can cause damage to the transmitter. For this reason, it is important to know the function of every control. The actual operation of the equipment is described in paragraphs 19 through 21.

18. Radio Transmitter T-195/GRC-19, Controls

(figs. 9 and 123)

- The front panel controls of the transmitter and their functions are listed in the chart below.

Control	Function														
SERVICE SELECTOR switch (S606)-----	<table border="0"> <thead> <tr> <th><i>Position</i></th> <th><i>Function</i></th> </tr> </thead> <tbody> <tr> <td>OFF-----</td> <td>Turns off power to the transmitter.</td> </tr> <tr> <td>VOICE/FSK----</td> <td>Used for sending radioteletype or voice signals.</td> </tr> <tr> <td>STAND BY----</td> <td>Keeps tubes heated and blower motor in operation.</td> </tr> <tr> <td>CW-----</td> <td>Used for sending continuous wave (cw) signals.</td> </tr> <tr> <td>CALIB-----</td> <td>Used for calibrating the transmitter.</td> </tr> <tr> <td>REMOTE-----</td> <td>Allows operation from remote point using transmitter control C-822/GRC-19.</td> </tr> </tbody> </table>	<i>Position</i>	<i>Function</i>	OFF-----	Turns off power to the transmitter.	VOICE/FSK----	Used for sending radioteletype or voice signals.	STAND BY----	Keeps tubes heated and blower motor in operation.	CW-----	Used for sending continuous wave (cw) signals.	CALIB-----	Used for calibrating the transmitter.	REMOTE-----	Allows operation from remote point using transmitter control C-822/GRC-19.
<i>Position</i>	<i>Function</i>														
OFF-----	Turns off power to the transmitter.														
VOICE/FSK----	Used for sending radioteletype or voice signals.														
STAND BY----	Keeps tubes heated and blower motor in operation.														
CW-----	Used for sending continuous wave (cw) signals.														
CALIB-----	Used for calibrating the transmitter.														
REMOTE-----	Allows operation from remote point using transmitter control C-822/GRC-19.														
RELAY-NORMAL-DUPLEX switch (S602)---	<table border="0"> <tbody> <tr> <td>RELAY-----</td> <td>Used for relaytype operation.</td> </tr> <tr> <td>NORMAL-----</td> <td>Used for simplex operation. Receiver is disabled when transmitter is operated.</td> </tr> <tr> <td>DUPLEX-----</td> <td>Used for operation of transmitter and receiver at the same time.</td> </tr> </tbody> </table>	RELAY-----	Used for relaytype operation.	NORMAL-----	Used for simplex operation. Receiver is disabled when transmitter is operated.	DUPLEX-----	Used for operation of transmitter and receiver at the same time.								
RELAY-----	Used for relaytype operation.														
NORMAL-----	Used for simplex operation. Receiver is disabled when transmitter is operated.														
DUPLEX-----	Used for operation of transmitter and receiver at the same time.														
BAND indicator-----	Shows the low end and the high end of the transmitter frequency band picked by the BAND SELECTOR control. The ten frequency bands are as follows: <table border="0" style="margin-left: 40px;"> <tbody> <tr> <td>1.5 to 1.7 mc.</td> <td>4.0 to 6.0 mc.</td> </tr> <tr> <td>1.7 to 2.0 mc.</td> <td>6.0 to 9.0 mc.</td> </tr> <tr> <td>2.0 to 2.4 mc.</td> <td>9.0 to 12.0 mc.</td> </tr> <tr> <td>2.4 to 3.0 mc.</td> <td>12.0 to 16.0 mc.</td> </tr> <tr> <td>3.0 to 4.0 mc.</td> <td>16.0 to 20.0 mc.</td> </tr> </tbody> </table>	1.5 to 1.7 mc.	4.0 to 6.0 mc.	1.7 to 2.0 mc.	6.0 to 9.0 mc.	2.0 to 2.4 mc.	9.0 to 12.0 mc.	2.4 to 3.0 mc.	12.0 to 16.0 mc.	3.0 to 4.0 mc.	16.0 to 20.0 mc.				
1.5 to 1.7 mc.	4.0 to 6.0 mc.														
1.7 to 2.0 mc.	6.0 to 9.0 mc.														
2.0 to 2.4 mc.	9.0 to 12.0 mc.														
2.4 to 3.0 mc.	12.0 to 16.0 mc.														
3.0 to 4.0 mc.	16.0 to 20.0 mc.														
CHAN indicator-----	Shows the channel to which the transmitter is tuned.														
Transmitter frequency indicator (located between the 2 meters).	Shows the transmitter operating frequency on one of the four counter mechanisms which is selected by the BAND SELECTOR control. The frequency is changed by the TUNING CONTROL. To change the reading from megacycles to kilocycles, drop the decimal point.														
BAND SELECTOR control-----	Selects any one of ten transmitter frequency bands. (The purpose of the locking bar on the front of this control is to lock the BAND SELECTOR control for preset operation. When the locking bar is loose, a red dot can be seen on the face of the knob.)														
TUNING CONTROL-----	Tunes the transmitter within the band picked by the BAND SELECTOR control. (The purpose of the locking bar on the front of this control is to lock the TUNING CONTROL for preset operation. When the locking bar is loose, a red dot can be seen on the face of the knob.)														
DIAL ZERO control-----	Used for calibration of the transmitter.														
PRESENT CHANNELS switch (S604)-----	Picks any one of the seven preset channels, or channel M for manual operation. There is a reminder spring on this control which locks the PRESET CHANNELS switch in the M position. The purpose of this spring is to remind the operator to lock the BAND SELECTOR control and the TUNING CONTROL before turning the PRESET CHANNELS switch from the M position. This reminder spring must be pushed in to release the PRESET CHANNELS switch.														
Test meter (M602) (located above the BAND SELECTOR control).	This meter shows the currents and the voltage of the circuits picked by the TEST METER switch.														
TEST METER switch (S607)-----	<table border="0"> <thead> <tr> <th><i>Position</i></th> <th><i>Function</i></th> </tr> </thead> <tbody> <tr> <td>PA GRID-----</td> <td>Connects the test meter so that it shows the power-amplifier grid current.</td> </tr> <tr> <td>BATT-----</td> <td>Connects the test meter so that it shows the battery voltage.</td> </tr> <tr> <td>PA CATH-----</td> <td>Connects the test meter so that it shows the power-amplifier cathode current.</td> </tr> </tbody> </table>	<i>Position</i>	<i>Function</i>	PA GRID-----	Connects the test meter so that it shows the power-amplifier grid current.	BATT-----	Connects the test meter so that it shows the battery voltage.	PA CATH-----	Connects the test meter so that it shows the power-amplifier cathode current.						
<i>Position</i>	<i>Function</i>														
PA GRID-----	Connects the test meter so that it shows the power-amplifier grid current.														
BATT-----	Connects the test meter so that it shows the battery voltage.														
PA CATH-----	Connects the test meter so that it shows the power-amplifier cathode current.														
Audio level meter (M603) (located above the TUNING CONTROL).	This meter shows the amount of the audio signal at output of the modulator. The meter readings are shown in volume units (vu) and percentage of modulation.														
LINE LEVEL control (R602)-----	Used to adjust the amount of voice signal that is applied to the transmitter modulator from the receiver during relay operation. As this control is turned to the right (clockwise) the percentage of modulation will increase (the audio level meter will indicate more to the right).														
TEST KEY (S603)-----	In the ON position, this key puts the transmitter on the air for tuning or testing.														

Control	Function
TUNING INDICATOR (I605)	When this stays lighted, it shows that the automatic tuning of the transmitter is finished.
DIAL DIM switch (S609)	Controls brightness light from the dial lamps and TUNING INDICATOR. When this control is in OVERHEAT CHECK RED LIGHT ON position and tuning indicator is lighted, a thermal overload is indicated.
50 OHMS OUTPUT connector (J614)	Used for connecting an antenna cable that has a UG-21B/U plug. There is a cover guard which covers this connector.
WHIP ANTENNA binding post (J615) (located to the right of the 50 OHMS OUTPUT connector).	Used for connecting a whip antenna.
RECEIVER ANTENNA connector (J616)	Used for connecting the receiver and the transmitter antenna circuits.
AUDIO connector (J603)	Used for connecting a headset, a microphone, or a telegraph key.
24 VOLTS DC connector (J605)	Used for connecting the power to the radio set.
FSK IN connector (J613)	Used for connecting a frequency-shift keyer for radioteletype operation.
MO OUT connector (J602)	Used for connecting a frequency-shift keyer for radioteletype operation.
REMOTE CONT connector (J601)	Used for connecting Transmitter Control C-822/GRC-19 for remote control operation.
RECEIVER CONT connector (J604)	Used for connecting the receiver to the transmitter.
GROUND binding post	Used for connecting the ground wire.
FUSE 15 AMP 24 VOLT (F601)	Protects the transmitter from damage.
FUSE 10 AMP 24 VOLT (F602)	Protects D601.
FUSE 30 AMP 24 VOLT (F603)	Protects D602.
Frequency chart	A place to write the frequency and the band of the preset channels.

b. The internal controls and their functions are listed below:

Control	Function
MODULATION (R419)	Adjusts modulation level.
CLIPPING (R414)	Adjusts peak level of audio input signal.
SIDETONE (R436)	Adjusts volume of sidetone signal.

Section III. PRESETTING AND INITIAL ADJUSTMENT OF EQUIPMENT

19. General

The presetting of the transmitter consists of setting up one or more (up to eight) frequency channels. One channel at the M position of the PRESET CHANNELS switch is reserved for manual tuning purposes, although it also can be preset to a particular frequency. After the new frequencies are set up on the Autotune system, the operator can start the transmitter without having to tune or load any of the stages. The Autotune system tunes the master oscillator and the exciter and selects the band switches; the servo systems properly tune and load the power amplifier (pa) and antenna network. Prior to presetting, if any doubt exists concerning the accuracy of the operating frequency, the transmitter should be initially adjusted as outlined for zero dial adjustment (par. 21).

20. Presetting Radio Transmitter T-195/GRC-19

To preset a frequency channel, connect the equipment as explained in paragraph 15 and then perform the preliminary starting procedure outlined in paragraph 22a. Then proceed as follows:

a. Turn the SERVICE SELECTOR switch to STAND BY.

b. Determine the new frequency channel number that is to be used by referring to the frequency chart on the front panel. Turn the PRESET CHANNELS switch to this numbered position.

c. Turn the locking key on the BAND SELECTOR knob in a counterclockwise direction. Observe the band-channel indicator and turn the BAND SELECTOR to the band in which the new frequency assignment lies. *Secure the locking key by turning it clockwise.*

d. Turn the locking key on the TUNING CONTROL in a counterclockwise direction. Observe the frequency indicator and rotate the TUNING CONTROL to the new assigned frequency. *Secure the locking key.*

e. Check the presetting operation by turning the PRESET CHANNELS switch to another frequency channel. After the Autotune cycle is completed, return this switch to the new frequency channel; observe that the BAND SELECTOR and TUNING CONTROL knobs operate and bring the new frequency into view on the frequency indicator.

f. Turn the SERVICE SELECTOR switch to CALIB.

g. Turn the TEST METER switch to PA GRID. The test meter should indicate within the shaded area marked PA GRID. If this indication is not obtained, refer to the equipment performance checklist (par. 41).

h. Write the new channel number, band number, and frequency on the frequency table of the front panel.

21. Zero Dial Adjustment

The calibration or zero dial adjustment of the transmitter is facilitated when the transmitter is installed as part of Radio Set AN/GRC-19 using an associated Radio Receiver R-392/URR. Refer to TM 11-274. Any communications receiver in good operating condition, with an accurate tuning system and a beat-frequency oscillator, can be used to obtain the same result. Before calibrating the transmitter, the equipment should be allowed to warm in the standby condition for at least 20 minutes to minimize frequency drift; be sure that the receiver beat-frequency oscillator (bfo) is switched on. To calibrate the transmitter using Radio Receiver R-392/URR, proceed as follows:

a. Calibrate the radio receiver for accuracy of frequency in accordance with the instructions given in its manual. Check to see that the receiver bfo is set at its zero-beat position.

b. Carefully set the radio receiver tuning dial to the operating frequency of the transmitter preset channel for which the calibration is to be made. If the receiver is located in the vicinity of the transmitter, remove the receiver antenna to prevent overloading.

c. Preset the transmitter as described in paragraph 22a, but *do not tighten the locking key of the TUNING CONTROL.*

d. Turn the SERVICE SELECTOR switch to CALIB.

e. Turn the TUNING CONTROL until the beat note (heard at the receiver) between the transmitter carrier and the receiver bfo is at zero. *Tighten the locking key.*

f. Read the operating frequency on the counter of the frequency indicator. If this reading differs from the assigned or true frequency by .03 percent plus 1,000 cycles, push the DIAL ZERO knob in, and turn the counter until the true frequency is shown.

Note. It is not necessary to put an antenna on the receiver or to connect the receiver to the transmitter.

CHAPTER 3

OPERATION

Section I. OPERATION UNDER USUAL CONDITIONS

Warning: The voltages used are dangerous. While the transmitter is operating, radio-frequency (rf) power is present at the transmission line and antenna. Be careful not to come into accidental contact with the antenna circuit, since this may result in severe rf burns or shock. Never use pencils or other objects to draw arcs from the

antenna. Be sure the equipment is adequately grounded. Be sure the WHIP ANTENNA binding post is always covered by the protective cap provided.

22. Starting Procedure

a. Preliminary. Set the front panel controls as follows:

Control	Position
SERVICE SELECTOR.....	OFF.
RELAY-NORMAL-DUPLEX.....	NORMAL.
BAND SELECTOR.....	Locking key tight, red dot does not show.
TUNING CONTROL.....	Locking key tight, red dot does not show.
PRESET CHANNELS.....	To desired operating channel.
TEST METER.....	BATT.
DIAL DIM.....	OFF.
LINE LEVEL.....	-34.

b. Starting:

Caution: Do not attempt to operate the transmitter if it is not terminated into a proper rf load (fig. 66).

- (1) Check to see that all cables and accessories are connected properly and that the intake and exhaust vents are open.
- (2) Turn the SERVICE SELECTOR switch to CALIB. If any of the following actions do not occur, refer to the equipment performance checklist (par. 41).
 - (a) The test meter (fig. 9) should indicate on midpoint of BATTERY scale.
 - (b) The air-exhaust blower should send an air blast outward through each of the two air-exhaust ports (fig. 9). The pa blower should suck air through the air-intake port (fig. 9). (The blower wheel can be observed by removing the

port cover and carefully taking out the air filter.)

- (c) The low-voltage (1v) dynamotor should start within 40 seconds plus or minus 10 seconds.
- (3) Rotate the DIAL DIM switch to each of its first three positions, in turn. The pilot lamps behind the windows of the band-channel and frequency indicators should change brilliancy with respect to the position of the switch.

Note. The TUNING INDICATOR should not light.

- (4) Turn the TEST METER switch to PA GRID and operate the PRESET CHANNELS switch to each of its eight channel positions, in turn. A complete Autotune cycle should be completed with each of the switch positions. (Note that

the reminder spring must be depressed to leave the M position.) Grid current should be indicated within the shaded area marked PA GRID on the test meter (fig. 9) after each Autotune cycle. Set the PRESET CHANNELS switch on one of the channels on which transmission is desired.

- (5) Turn the TEST METER switch to PA CATH and turn the SERVICE SELECTOR to CW. After a 10-second, or less, time interval, the high-voltage dynamotor should start. The test meter should indicate zero.
- (6) Hold the TEST KEY at ON. Wait until the tuning cycle is completed; this is indicated by the TUNING INDICATOR lamp remaining lighted, and an indication within the shaded area of the PA CATHODE scale of test meter M602. Before the automatic tuning cycle is completed, the TUNING INDICATOR may flash sporadically, and current indications on the meter will fluctuate between below and above normal values.
- (7) Turn the SERVICE SELECTOR switch to STAND BY. The dynamotors should stop.
- (8) Refer to paragraph 23 for type of operation required.

Note. If, during operation, the transmitter shuts down, operate the DIAL DIM switch to the OVERHEAT CHECK-RED LIGHT ON position. If the TUNING INDICATOR lights, a thermal overload is indicated. Check blower port covers for proper position and remove any obstructions to the air flow. Switch the service SELECTOR switch to OFF, and then switch back to VOICE/FSK position. The TUNING INDICATOR should go out. Check that all blowers are operating. If the TUNING INDICATOR is still lighted, turn the SERVICE SELECTOR switch to OFF position and wait a few minutes for the transmitter to cool. Again operate the SERVICE SELECTOR switch to VOICE/FSK position. If the TUNING INDICATOR is still lighted, the transmitter will require trouble shooting at a higher echelon.

23. Types of Operation

a. General. Radio Transmitter T-195/GRC-19 provides service for cw, voice, or fsk operation. The three types of operation can be used in relay, normal, or duplex system application, as selected

by the RELAY-NORMAL-DUPLEX switch on the front panel (fig. 9). Details of operation using relay or duplex system application are not provided in this manual, but are given in TM 11-274. The three types of operation outlined in *b* and *c* below are for normal system application only. The transmitter can be operated remotely for cw, voice, or fsk operation, when connected to Transmitter Control C-822/GRC-19 (par. 15e).

b. Cw Operation. Accessory equipment must be connected to the transmitter as directed in paragraph 15d(2). After performing the preliminary and starting procedures outlined in paragraph 22a, proceed as follows:

- (1) Turn the SERVICE SELECTOR to CW.
- (2) Turn TEST METER switch to PA CATH position.
- (3) Turn the TEST KEY to ON or depress the telegraph key. The dynamotors should start, and the TUNING INDICATOR should light when the transmitter is tuned. A 400-cycle sidetone signal should be heard in the headset, and a current indication should be obtained within the shaded area marked PA CATHODE on the test meter (fig. 9).

Caution: Do not operate this equipment, key down, for periods longer than 15 minutes on frequencies lower than two megacycles when using the whip antenna. Such extended periods of operation may damage the equipment.

- (4) Turn the TEST KEY to OFF, or lift up the telegraph key. The sidetone signal should no longer be heard, and there should be no indication on the TUNING INDICATOR and test meter.

c. Voice Operation. Accessory equipment must be connected to the transmitter as directed in paragraph 15d(1). After performing the preliminary and starting procedures outlined in paragraph 22a, proceed as follows:

- (1) Turn the SERVICE SELECTOR to VOICE/FSK.
- (2) Turn the TEST KEY to ON, or press the microphone button. The dynamotors should start, and the TUNING INDICATOR should light when the transmitter is tuned. The test meter (fig. 9)

- should indicate current within the shaded area marked PA CATHODE.
- (3) Turn the TEST KEY to OFF, or release the microphone button. The dynamotors should stop and there should be no indication on the TUNING INDICATOR and test meter.
 - (4) Hold the microphone about 2 inches from the lips. Press the microphone switch and speak in a normal voice. The needle on the test meter should fluctuate slightly. Voice peaks should produce 80 percent or -2 VU indication on the audio level meter (fig. 9).
 - (5) If the transmitter is modulated properly, as shown by the indications described in

(4) above, proceed with the message transmission. If it is not, refer to the trouble-shooting information in this manual.

24. Stopping Procedure

a. When the transmitter is not to be used for a short interval but is to be maintained in a state of readiness, turn the SERVICE SELECTOR switch to STAND BY.

b. Turn the SERVICE SELECTOR switch to OFF if equipment is not to be used.

Caution: Never turn the SERVICE SELECTOR switch to OFF while the Autotune system is cycling.

Section II. OPERATION UNDER UNUSUAL CONDITIONS

25. General

The operation of radio equipment becomes more difficult in regions where extreme cold, heat, humidity and moisture, sand conditions, etc., prevail. Procedures are given in paragraphs 26, 27, and 28 for minimizing the effect of these unusual operating conditions.

26. Operation in Arctic Climate

Subzero temperatures and climatic conditions associated with cold weather may affect the efficient operation of the equipment. Instructions and precautions for operation under such adverse conditions follow:

a. Handle the equipment carefully.

b. Keep the equipment warm and dry. Keep the heaters (if supplied) turned on, provided this does not overtax the power supply. If this method is impracticable, keep the filaments of the vacuum tubes lighted constantly by turning the SERVICE SELECTOR switch to STAND BY.

c. Heavy coatings of frost will gather on the microphones in extreme cold weather when the microphones are used in the open air or in a cold room. Breath will form frost in the small holes of the cap and will affect transmitter modulation. Rubber diaphragms have been designed to protect some types of microphones; use them when available. If possible, have a spare microphone ready, in case the one in use fails to function properly.

d. Wear a knitted woolen cap over the earphones when operating in the open air with head-

sets that do not have rubber earpieces. Frequently, when headsets without rubber earpieces are worn, the edges of the ears may freeze without the operator being conscious of this condition. Never flex rubber earpieces, since this action may render them useless. If water gets into the earphones, or moisture condenses within them, ice may result and impede the action of the diaphragms. When this happens, unscrew the bakelite cap and remove the ice and moisture.

e. Storage batteries must be maintained at full charge to prevent freezing. When batteries become discharged, recharge them immediately. Batteries that are not in regular use should be left on trickle charge.

f. If the equipment has been exposed to low temperatures during inoperation, it can be warmed in shorter time by turning the SERVICE SELECTOR switch to the CALIB position.

27. Operation in Tropical Climate

When operated in a tropical climate, radio equipment may be installed in tents or huts. When equipment is set up in swampy areas, moisture conditions are more acute than those normally met in the tropics. Ventilation usually is poor, and the high relative humidity causes condensation of moisture on the equipment whenever the temperature of the equipment becomes lower than that of the surrounding air. Precautions should be taken to keep equipment dry.

28. Operation in Desert Climate

a. Conditions similar to those encountered in tropical climates often prevail in desert areas. Use the same measures to insure proper operation of the equipment.

b. The main problem which arises with equipment operation in desert areas is the large amount of sand, dust, or dirt which enters the moving parts of the equipment, such as motors and generators. Keep the air filter clean at all times. Two spare air filters are provided with each equipment.

c. Never tie power cords, signal cords, or other

wiring connections to either the inside or the outside of tents. Desert areas are subject to sudden winds which may jerk the connections loose or break the lines.

d. Keep the equipment as free from dust as possible. Make frequent preventive maintenance checks (par. 34). Pay particular attention to the lubrication of the equipment. Excessive amounts of dust, sand, or dirt that come into contact with oil and grease result in grit, which will damage the equipment. Under extreme conditions, check and clean air filter regularly every 24 hours. Keep the intake and exhaust blower ports closed when the equipment is not in use.

CHAPTER 4

ORGANIZATIONAL MAINTENANCE

Section I. ORGANIZATIONAL TOOLS AND TEST EQUIPMENT

29. Tools, Materials, and Equipment Required

a. The tools and materials contained in Tool Equipment TE-41 (the ordinary hand tools and materials normally available to organizational maintenance personnel) are required for organizational maintenance of Radio Transmitter T-195/GRC-19. In addition, Cleaning Compound should be available.

b. Multimeter TS-297/U and Electron Tube Test Set TV-7/U are the equipment required for organizational maintenance.

30. Special Tools Supplied with Radio Transmitter T-195/GRC-19

(fig. 10)

The tube pullers supplied with the transmitter are mounted on the inside of one side plate of the main frame (fig. 5). Two cable grip-type tube pullers are furnished: one for 7-pin miniature

tubes, and the other for 9-pin miniature tubes. To remove a tube, slide a tube puller of the proper size over the tube envelope. Pull upward on the tool and at the same time, wobble the tube slightly. After the tube has been removed from its socket, remove the tube from the tool by pushing the tube toward the handle.

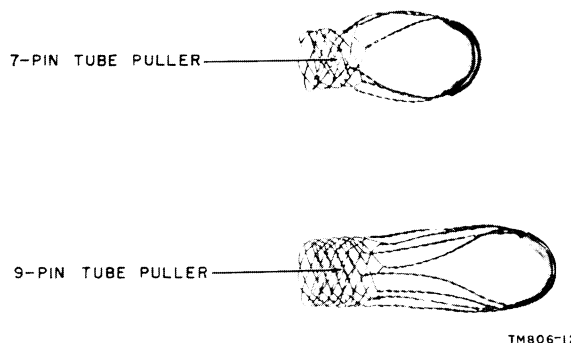

Figure 10. Special tools.

Section II. PREVENTIVE MAINTENANCE SERVICES

31. Definition of Preventive Maintenance

Preventive maintenance is work performed on equipment (usually when the equipment is not in use) to keep it in good working order so that breakdowns and needless interruptions in service will be kept to a minimum. Preventive maintenance differs from trouble shooting and repair in that its object is the prevention of certain troubles rather than their correction. See AR 750-5, Maintenance of Supplies and Equipment.

32. General Preventive Maintenance Techniques

a. Use No. 0000 sandpaper to remove corrosion.

Caution: Do not use steel wool in place of No. 0000 sandpaper; minute metallic particles can

cause equipment failure as a result of internal shorting or grounding of circuits.

b. Use a clean, dry, lint-free cloth or a dry brush for cleaning. Clean accessible parts with a cloth moistened with Cleaning Compound. Then wipe the parts dry with a cloth.

Warning: Prolonged breathing of Cleaning Compound fumes is dangerous. Make sure adequate ventilation is provided. Cleaning Compound is flammable; do not use near a flame.

c. If available, dry compressed air can be used at a line pressure not exceeding 30 pounds per square inch to remove dust and foreign matter from inaccessible mechanical components.

Caution: Great care should be taken, when directing the air jet, not to disturb wiring, or cause mechanical damage to delicate parts.

d. For further information on preventive maintenance techniques, refer to TB SIG 178, Preventive Maintenance Guide for Radio Communication Equipment.

33. Use of Preventive Maintenance Form

a. The decision as to what items on DA Form 11-239 are applicable to this equipment is a decision to be made in the case of first echelon maintenance by the communication officer/chief or his designated representative, and in the case of second and third echelon maintenance, by the individual making the inspection. Instructions for the use of the form appear on the reverse side.

b. Circled items in figure 11 are partially or wholly applicable to Radio Transmitter T-195/GRC-19. Paragraph references in the ITEM column indicate paragraphs in the manual which give additional or detailed information.

34. Performing Preventive Maintenance

Caution: Tighten screws, bolts, and nuts carefully. Fittings tightened beyond the pressure for which they are designed will be damaged or broken.

a. *Performing Exterior Preventive Maintenance.* Preventive maintenance is performed on the exterior of the equipment as follows:

- (1) Check the equipment against the table of components (par. 7), list of running spares (par. 10), and list of additional equipment required (par. 11), to see that no components or parts are missing. Observe the general condition of the equipment.
- (2) Check the suitability of the siting location and the installation (par. 12a and b) for normal operation. Provide for operation under unusual conditions (pars. 26, 27, and 28) such as in excessively dusty, damp, windy, hot, or cold areas.
- (3) Use a clean, lint-free cloth to remove dust, dirt, moisture, and grease from the antenna, antenna base, front panel, case, microphone, headset, telegraph key, and other accessory or auxiliary equipment.
- (4) Operate the controls to check for binding, scraping, excessive looseness, and positive action. Rough action or binding of the BAND SELECTOR control and TUNING CONTROL indicates a dam-

aged tuning system or the need for cleaning and lubrication.

- (5) Check for normal operation of the transmitter (par. 41).
 - (6) Clean and tighten the hardware on the exterior of the case, front panel, mount, and ground straps. Use a clean, lint-free cloth dampened in cleaning compound; then wipe the parts dry.
 - (7) Inspect the case for corrosion. Remove rust and touch up bare spots (par. 37).
 - (8) Inspect all external cables for cuts, breaks, fraying, deterioration, kinks, and strain.
 - (9) Check manuals for completeness and general condition.
 - (10) Inspect the cable connectors on the front panel for looseness in the receptacles. Hand-tighten the coupling nuts. Inspect the knobs on the front panel for looseness and, if necessary, tighten the set screws. Inspect the generator for loose mounting, frayed or loose terminals, signs of overheating, and damage to the case.
 - (11) Check the storage batteries for loose terminals and corrosion. Wipe the terminals clean, apply a thin layer of vaseline, if available, and tighten the terminal connections. See that the level of the electrolyte is kept up to normal level with distilled water, and that specific gravity is normal, as checked with a hydrometer.
 - (12) Use a clean, damp cloth to clean the glass windows of the front panel meters and indicators. Clean the nameplate. Clean the air filter as follows:
 - (a) Remove the air-intake cover (located at the lower-right center of the front panel).
 - (b) Clean the filter by submerging and agitating it in cleaning compound.
- Warning:** Cleaning compound is recommended as the cleaning agent, and the quantity should be sufficient to submerge the filter. All precautions used in handling cleaning compound should be strictly followed (par. 32b.). After removal, place the filter in an open or well-ventilated place, to allow the cleaning compound to evaporate.

SECOND AND THIRD ECHELON MAINTENANCE CHECK LIST FOR SIGNAL CORPS EQUIPMENT			
RADIO COMMUNICATION, DIRECTION FINDING, CARRIER, RADAR			
INSTRUCTIONS: See other side			
EQUIPMENT NOMENCLATURE		EQUIPMENT SERIAL NO.	
LEGEND FOR MARKING CONDITIONS: ✓ Satisfactory; X Adjustment, repair or replacement required; ⊕ Defect corrected. NOTE: Strike out items not applicable.			
NO.	ITEM	NO.	ITEM
①	COMPLETENESS AND GENERAL CONDITION OF EQUIPMENT (receiver, transmitter, carrying cases, wire and cable, microphones, tubes, spare parts, technical manuals and accessories). PAR. 34 a (1)	19	ELECTRON TUBES - INSPECT FOR LOOSE ENVELOPES, CAP CONNECTORS, CRACKED SOCKETS; INSUFFICIENT SOCKET SPRING TENSION; CLEAN DUST AND DIRT CAREFULLY; CHECK EMISSION OF RECEIVER TYPE TUBES.
②	LOCATION AND INSTALLATION SUITABLE FOR NORMAL OPERATION. PAR. 34 a (2)	20	INSPECT FIRM CUT-OUTS FOR LOOSE PARTS, DIRT, MISALIGNMENT AND CORROSION.
③	CLEAN DIRT AND MOISTURE FROM ANTENNA, MICROPHONE, HEADSETS, CHESTSETS, KEYS, JACKS, PLUGS, TELEPHONES, CARRYING BAGS, COMPONENT PANELS. PAR. 34 a (3)	21	INSPECT FIXED CAPACITORS FOR LEAKS, BULGES, AND DISCOLORATION. PAR. 34 b (1)
④	INSPECT SEATING OF READILY ACCESSIBLE "PLUCK-CUT" ITEMS: TUBES, LAMPS, CRYSTALS, FUSES, CONNECTORS, VIBRATORS, PLUG-IN COILS AND RESISTORS.	22	INSPECT RELAY AND CIRCUIT BREAKER ASSEMBLIES FOR LOOSE MOUNTINGS; BURNED, PITTED, CORRODED CONTACTS; MISALIGNMENT OF CONTACTS AND SPRINGS; INSUFFICIENT SPRING TENSION; BINDING OF PLUNGERS AND HINGE PARTS. PAR. 34 b (2)
⑤	INSPECT CONTROLS FOR BINDING, SCRAPING, EXCESSIVE LOOSENESS, WORN OR CHIPPED GEARS, MISALIGNMENT, POSITIVE ACTION. PAR. 34 a (4)	23	INSPECT VARIABLE CAPACITORS FOR DIRT, MOISTURE, MISALIGNMENT OF PLATES, AND LOOSE MOUNTINGS. PAR. 34 b (3)
⑥	CHECK FOR NORMAL OPERATION. PAR. 34 a (5)	24	INSPECT RESISTORS, BUSHINGS, AND INSULATORS, FOR CRACKS, CHIPPING, BLISTERING, DISCOLORATION AND MOISTURE. PAR. 34 b (4)
⑦	CLEAN AND TIGHTEN EXTERIOR OF COMPONENTS AND CASES, RACK MOUNTS, SHOCK MOUNTS, ANTENNA MOUNTS, COAXIAL TRANSMISSION LINES, WAVE GUIDES, AND CABLE CONNECTIONS. PAR. 34 a (6)	25	INSPECT TERMINALS OF LARGE FIXED CAPACITORS AND RESISTORS FOR CORROSION, DIRT AND LOOSE CONTACTS. PAR. 34 b (5)
⑧	INSPECT CASES, MOUNTINGS, ANTENNAS, TOWERS, AND EXPOSED METAL SURFACES, FOR RUST, CORROSION, AND MOISTURE. PAR. 34 a (7)	26	CLEAN AND TIGHTEN SWITCHES, TERMINAL BLOCKS, BLOWERS, RELAY CASES, AND INTERIORS OF CHASSIS AND CABINETS NOT READILY ACCESSIBLE. PAR. 34 b (6)
⑨	INSPECT CORD, CABLE, WIRE, AND SHOCK MOUNTS FOR CUTS, BREAKS, FRAYING, DETERIORATION, KINKS, AND STRAIN. PAR. 34 a (8)	27	INSPECT TERMINAL BLOCKS FOR LOOSE CONNECTIONS, CRACKS AND BREAKS. PAR. 34 b (7)
10	INSPECT ANTENNA FOR ECCENTRICITIES, CORROSION, LOOSE FIT, DAMAGED INSULATORS AND REFLECTORS.	28	CHECK SETTINGS OF ADJUSTABLE RELAYS.
⑩	INSPECT CANVAS ITEMS, LEATHER, AND CABLING FOR MILDEW, TEARS, AND FRAYING. PAR. 34 a (9)	29	LUBRICATE EQUIPMENT IN ACCORDANCE WITH APPLICABLE DEPARTMENT OF THE ARMY LUBRICATION ORDER.
⑪	INSPECT FOR LOOSENESS OF ACCESSIBLE ITEMS: SWITCHES, KNOBS, JACKS, CONNECTORS, ELECTRICAL TRANSFORMERS, POWERSTATS, RELAYS, SELSYNS, MOTORS, BLOWERS, CAPACITORS, GENERATORS, AND PILOT LIGHT ASSEMBLIES. PAR. 34 a (10)	30	INSPECT GENERATORS, AMPLIDYNES, DYNAMOTORS, FOR BRUSH WEAR, SPRING TENSION, ARCING, AND FITTING OF COMMUTATOR. PAR. 34 b (8)
⑫	INSPECT STORAGE BATTERIES FOR DIRT, LOOSE TERMINALS, ELECTROLYTE LEVEL AND SPECIFIC GRAVITY, AND DAMAGED CASES. PAR. 34 a (11)	31	CLEAN AND TIGHTEN CONNECTIONS AND MOUNTINGS FOR TRANSFORMERS CHOKES, POTENTIOMETERS, AND RHEOSTATS. PAR. 34 b (9)
⑬	CLEAN AIR FILTERS, BRASS NAME PLATES, DIAL AND METER WINDOWS, JEWEL ASSEMBLIES. PAR. 34 a (12)	32	INSPECT TRANSFORMERS, CHOKES, POTENTIOMETERS, AND RHEOSTATS FOR OVERHEATING AND OIL-LEAKAGE. PAR. 34 b (10)
⑭	INSPECT METERS FOR DAMAGED GLASS AND CASES. PAR. 34 a (13)	33	BEFORE SHIPPING OR STORING - REMOVE BATTERIES.
16	INSPECT SHELTERS AND COVERS FOR ADEQUACY OF WEATHERPROOFING.	34	INSPECT CATHODE RAY TUBES FOR BURNT SCREEN SPOTS.
17	CHECK ANTENNA GUY WIRES FOR LOOSENESS AND PROPER TENSION.	35	INSPECT BATTERIES FOR SHORTS AND DEAD CELLS. PAR. 34 b (11)
⑮	CHECK TERMINAL BOX COVERS FOR CRACKS, LEAKS, DAMAGED GASKETS, DIRT AND GREASE. PAR. 34 a (14)	36	INSPECT FOR LEAKING WATERPROOF GASKETS, WORN OR LOOSE PARTS. PAR. 34 b (12)
⑯	IF DEFICIENCIES NOTED ARE NOT CORRECTED DURING INSPECTION, INDICATE ACTION TAKEN FOR CORRECTION. PAR. 34 b (14)	37	MOISTURE AND FUNGIPROOF. PAR. 34 b (13)

DA FORM 11-239
1 MAY 51

REPLACES DA FORM 419, 1 DEC 50, WHICH IS OBSOLETE.

49-16-84282-1

TM 806-13

Figure 11. DA Form 11-239.

- (c) Saturate the filter with light-weight oil. Place the filter in a position to allow excess oil to drain for at least 2 hours.

Caution: Be sure that all excess oil has been removed; otherwise, oil will be scattered into the interior electrical areas of the transmitter by the intake blower.

- (d) Replace the filter by reversing the removal procedure. Two spare filters are provided with each equipment. The transmitter may be operated with a spare filter installed while the original filter is being cleaned.

- (13) Inspect the front panel meters and indicators for cracked or broken glass windows.

b. Performing Interior Preventive Maintenance. To perform interior maintenance, proceed as follows:

Warning: Disconnect all power before performing the following operations. When power to the transmitter is disconnected, some capacitors still may retain voltages of dangerous potential. Before touching exposed electrical parts, short-circuit the part to ground with a grounding stick having an insulated handle. When interior maintenance is completed, replace the transmitter in its case, reconnect the power, and check for satisfactory operation.

- (1) Inspect the fixed capacitors for leaks, bulges, and discoloration.
- (2) Inspect the relays for loose mounting; burned, pitted, or corroded contacts; misalignment of contacts and springs; and insufficient spring tensions.
- (3) Inspect the variable capacitors for dirt, moisture, misalignment of plates, and loose mountings.

- (4) Inspect the resistors and insulators for cracks, chipping, blistering, discoloration, and moisture.
- (5) Inspect the terminals of large fixed capacitors and resistors for corrosion, dirt, and loose contacts.
- (6) Clean and tighten the connectors in the transmitter. Clean and tighten the housings and mountings of blowers, motors, dynamotors, subchassis, etc.
- (7) Inspect the terminal strips for loose connections, cracks, and breaks.
- (8) Inspect the motors and dynamotors for signs of overheating. Check to see that oil or grease is not present on the dial-corrector clutch face (fig. 122). Inspection should be made soon after shutting down the transmitter. After 250 hours of operation, inspect the brushes on all motors and dynamotors for wear, spring tension, arcing, and correct fit to the commutators. The procedure for the removal and replacement of brushes is given in paragraph 108.
- (9) Clean and tighten the connections and mountings for transformers, coils, and potentiometers.
- (10) Inspect the transformers, coils, and potentiometers for signs of overheating. Inspection should be made soon after shutting down the transmitter.
- (11) After 250 hours of operation, test the germanium crystals in accordance with the procedure given in paragraph 107.
- (12) Inspect the gasket (fig. 102) in the flange of the front panel for wear or breaks. Inspect the transmitter for worn or loose parts.
- (13) If the deficiencies noted are not corrected during inspection, indicate the action taken for correction.

Section III. LUBRICATION AND WEATHERPROOFING

35. Lubrication

Lubrication is not to be performed on Radio Transmitter T-195/GRC-19 at *organizational maintenance level*.

36. Weatherproofing

a. General. Signal Corps equipment, when operated under severe climatic conditions such as

prevail in tropical, arctic, and desert regions, requires special treatment and maintenance. Fungus growth, insects, dust, corrosion, salt spray, excessive moisture, and extreme temperatures are harmful to most materials.

b. Tropical Maintenance. A special moisture-proofing and fungiproofing treatment has been devised which, if properly applied, provides a rea-

sonable degree of protection. This treatment is explained fully in TB SIG 13, Moistureproofing and Fungiproofing Signal Corps Equipment, and TB SIG 72, Tropical Maintenance of Ground Signal Equipment.

c. Winter Maintenance. Special precautions necessary to prevent poor performance or total operational failure of equipment in extremely low temperatures are explained fully in TB SIG 66, Winter Maintenance of Signal Equipment, and TB SIG 219, Operation of Signal Equipment at Low Temperatures.

d. Desert Maintenance. Special precautions necessary to prevent equipment failure in areas subject to extremely high temperatures, low humidity, and excessive sand and dust are explained fully in TB SIG 75, Desert Maintenance of Ground Signal Equipment.

Section IV. TROUBLESHOOTING AT ORGANIZATIONAL MAINTENANCE LEVEL

38. General

Warning: When servicing Radio Transmitter T-195/GRC-19, be extremely careful of exposed circuits carrying high voltages. When power to the transmitter is disconnected, some capacitors still may retain voltages of dangerous potential. Before touching exposed electrical parts after the voltage has been shut off, short-circuit the part to ground with a grounding stick having an insulated handle. **WHEN POWER TO THE TRANSMITTER IS ON, VOLTAGE AS HIGH AS 1,000 VOLTS DC OR 10,000 VOLTS RF IS PRESENT IN THE CIRCUITS OF THE TRANSMITTER.**

a. The troubleshooting and repairs that can be performed at the organizational maintenance level (operators and repairmen) are necessarily limited in scope by the tools, test equipment, replaceable parts issued, and by the existing situation. Accordingly, troubleshooting is based on the performance of the equipment and the use of the senses in determining such troubles as burned-out tubes, faulty indicator lamps, and open fuses.

b. Paragraphs 39 through 41 assist the repairman to determine which subchassis or functional circuit is at fault and in localizing the fault to the defective stage or part. Repair will be limited to the replacement of those parts included in the running spares or to repairs that can be accomplished by the organizational repairman.

37. Rustproofing and Painting

a. When the finish on the front panel or case has been badly scarred or damaged, clean the surfaces properly before touching up the bared surfaces with paint. Use No. 00 or No. 000 sandpaper to clean the surface down to the bare metal; obtain a bright, smooth finish. Use solvent (SD) to remove dirt and grease.

Caution: Do not use steel wool. Minute metallic particles can enter inside the case and cause equipment malfunction or failure as a result of internal shorting or grounding of circuits.

b. Apply paint with a small brush. The paint used will be MIL-P-13596 olive drab or equivalent. When a front panel marking has been obliterated, use a fine brush and white enamel to replace the marking.

39. Visual Inspection

a. Failure of the equipment to operate properly may be caused by one or more of the following faults:

- (1) Improperly connected, worn, or broken external or internal cables or plugs.
- (2) Safety interlock S611 (fig. 5) faulty or not properly closed.
- (3) Grounded or broken antenna or antenna lead-in.
- (4) Faulty primary power source.
- (5) Faulty brushes in dynamotors or motors.
- (6) Relay contacts burned because of overloads.
- (7) Burned-out fuses (usually indicative of another fault).
- (8) Defective tubes.
- (9) Wires broken because of excessive vibration.

b. When the transmitter fails to operate and the cause is not immediately apparent, check as many of the items in 1 through 9 above as practicable before starting a detailed examination. If possible, obtain information from the operator of the transmitter regarding performance at the time the trouble occurred.

c. When visually inspecting the tubes for burned-out filaments, it may be discovered that more than one tube is not lighted. Figure 12, which is a block diagram of the filament circuits,

shows that there are eight main filament branches fed from the 24-volt supply. If V203 is open, branch No. 1 will be entirely inoperative. If V204 is open, resistor R234 will limit the current through V203 making V203 inoperative. If V101, V102 or V103 is open, branch No. 2 will be inoperative. If V104 or V202 is open branch No. 3 is inoperative. Branch No. 4 and branch No. 5 are similar series filament strings. The failure of either branch No. 4 or branch No. 5 does not make the other branch inoperative, but, if one of the tubes in the branch is open, the whole branch is inoperative. If V404 is open, branch No. 6 is inoperative. If V402, V401, or V403 is open, resistor R417 limits current through V404 making it inoperative. Branch No. 7 consists only of V201. This tube has a 26-volt filament and operates directly from the 24-volt supply. Branch No. 8 consists of V406 and V407 in parallel. Both V406 and V407 have 26-volt filaments and operate directly from the 24-volt supply. When the SERVICE SELECTOR switch S606 is in

STANDBY position, the three tubes of branches Nos. 7 and 8 are connected to 24 volts through R622 and R623. Due to the voltage drop across R623 and R622, the voltage to V201, V406, and V407 is reduced approximately 20 percent. Branch No. 7 and branch No. 8 are also connected to 24 volts through CR601, F602 and contacts of the dynamotor start relay K602 when the microphone switch or the key is closed. This arrangement allows full filament voltage to be applied during operation. During periods of standby, the back resistance of CR601 is high enough to prevent operation of the dynamotor. A defective fuse F601 or defective relay K608 will cause all filament branches to be inoperative. If F602 or CR601 are defective, the tubes in branches Nos. 7 and 8 will have filament voltage reduced at all times. The reference symbol, function, type, location, and figure reference of each of the 21 tubes of the transmitter are listed in the following chart:

Reference Symbol	Function	Type	Location	Figure
V101	First multiplier.....	6AU6WA	Exciter subchassis.....	71
V102	Second multiplier.....	6AK6		
V103	Third multiplier.....	6AK6		
V104	Driver.....	5763	Power-amplifier subchassis.....	77
V201	Power amplifier.....	4X150D		
V202	Clamper.....	5763		
V203	Third servo amplifier.....	6005/6AQ5W	-----	79
V204	First and second servo amplifier.....	5751		
V401	Preamplifier and first audio amplifier.....	12AT7		
V402	Limiter.....	5726/6AL5W		
V403	Sidetone amplifier and antenna delay tube.....	12AT7		
V404	Second audio amplifier and phase inverter.....	5814	-----	86
V406	Modulator.....	4X150D		
V407	Modulator.....	4X150D		
V601	Voltage regulator.....	0A2	Main frame.....	97
V801	Oscillator.....	5749/6BA6W	Master oscillator subchassis.....	67
V802	Buffer amplifier.....	5749/6BA6W	Antenna-network servo-amplifier subchassis.	91
V901	First and second phasing amplifier.....	5751		
V902	Third phasing amplifier.....	6005/6AQ5W		
V903	First and second loading amplifier.....	5751		
V904	Third loading amplifier.....	6005/6AQ5W		

d. If tube troubleshooting is needed, follow the instructions in (1) through (5) below:

- (1) Before attempting to replace any tubes, inspect all cabling, connections, and the condition of the equipment. Try to isolate the trouble to a particular stage or

section to avoid needless replacement and testing of tubes.

- (2) If a tube tester is available, remove and test one tube at a time. Do not discard tubes merely because they fall on or slightly below the minimum acceptabil-

ity value. These tubes may provide satisfactory performance near this test value for a long period of time.

(3) If a tube tester is not available, troubleshoot by the tube substitution method in the following manner:

(a) Replace the suspected tubes, one at a time, with tubes known to be in good condition. Replace each substituted tube with the original one before removing a new tube. If the equipment becomes operative, discard the last tube removed. **DO NOT LEAVE A NEW TUBE IN THE SOCKET IF THE**

EQUIPMENT OPERATES SATISFACTORY WITH THE ORIGINAL TUBE.

(b) Remove the tube shields by pressing down and turning one-fourth turn counterclockwise. Do not rock or rotate any tube when removing it. Pull it straight up. Use the proper tube puller.

(4) Do not replace or discard tubes merely because they have been in use for some time. If the tube operates properly in the circuit, it should not be replaced.

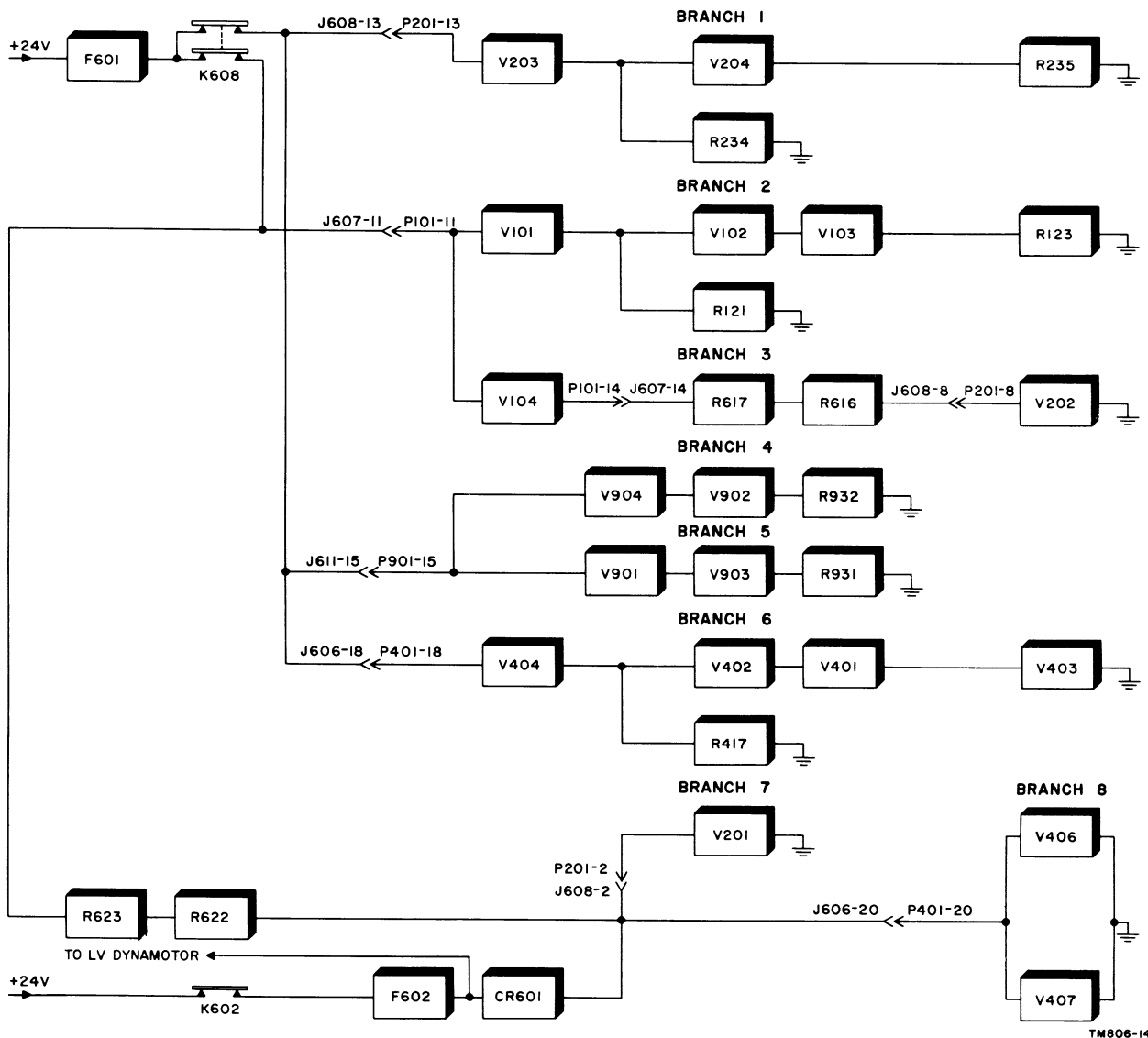

Figure 12. Radio Transmitter T-195/GRC-19, filament circuit block diagram.

- (5) Discard tubes only when the defect is obvious such as a broken envelope, open filament or a broken pin; also discard tubes if a tube tester or the equipment shows it to be defective.

40. Troubleshooting by Using Equipment Performance Checklist

a. General. The equipment performance checklist (par. 41) will help the repairman to locate trouble in the equipment. The list gives the items to be checked, the conditions under which the item is checked, the normal indications of correct operation, and the corrective measures to be taken. *To use this list, follow the items in numerical sequence.*

b. Action or Condition. For some items, the information given in the *Action or condition* column consists of various switch and control settings with which the items are to be checked. For other items, it represents an action that must be taken to check the normal indication given in the *Normal indications* column.

c. Normal Indications. The normal indications listed include the visible and audible signs that the repairman should see and hear when he checks the items. If the indications are not normal, the operator or repairman should apply the recommended corrective measures.

d. Corrective Measures. The corrective measures listed are those that the operator or repairman can make without turning in the equipment for repairs. A reference in the table to a paragraph indicates that the trouble cannot be corrected during operation, and that troubleshooting by an experienced repairman is necessary. If the transmitter is completely inoperative, or if the recommended corrective measures do not yield results, troubleshooting is necessary. However, if the situation requires that communication be maintained and if the transmitter is not completely inoperative, the operator must maintain the transmitter in operation as long as it is possible to do so.

41. Equipment Performance Checklist

	Item No.	Item	Action or condition	Normal indication	Corrective measures
P R E P A R A T O R Y	1	SERVICE SELECTOR switch.	Turn to OFF.		
	2	Antenna-----	Connect doublet to 50 OHMS OUTPUT or whip to WHIP. ANTENNA receptacle.		
	3	Power cable-----	Connect between 24 VOLTS DC receptacle and power source.		
	4	Ground wire-----	Connect between GROUND binding post and a good ground if transmitter is not installed on Mounting MT-851/GRC-19 or MT-925/GRC-19 in vehicle.		
	5	Telegraph key, microphone, or headset.	Connect to AUDIO receptacle.		
	6	RELAY-NORMAL-DUPLEX switch.	Turn to NORMAL.		
	7	BAND SELECTOR control.	Tighten locking key.		
	8	TUNING CONTROL.	Tighten locking key.		
	9	PRESET CHANNELS switch.	Rotate to same number shown under CHAN of band-channel indicator.		
	10	TEST METER switch.	Turn to BATT.		
	11	DIAL DIM switch.	Turn to OFF.		
	12	Blower port covers.	Each cover in open position.		

	Item No.	Item	Action or condition	Normal indication	Corrective measures
S T A R T	13	SERVICE SELECTOR switch.	Turn to CALIB-----	<p>Test meter indicates normal (midpoint BATTERY scale).</p> <p>Air intake and exhaust blowers operate (feel for movement of air).</p> <p>Low-voltage dynamotor starts within 40 seconds (can be heard).</p>	<p>If no meter indication check F601 (FUSE 15 AMP 24 VOLT) (fig. 9) and/or power cable and connections.</p> <p>If meter indication is abnormal, check and adjust power source between 28 and 29 volts dc, using external voltmeter.</p> <p>If fuse F601 continues to blow, refer to paragraph 101.</p> <p>If meter or circuit is faulty, refer to paragraph 103.</p> <p>Check plugs P1001 and P1101 (figs. 94 and 96) for proper seating.</p> <p>Refer to paragraph 103.</p> <p>Check to see that interlock switch S611 (fig. 5) is closed by retightening the 16 wing nuts at front panel edges.</p> <p>Check plug P401 for proper seating.</p> <p>Check fuse F602 (fig. 5).</p> <p>If fuse F602 continues to blow, refer to paragraph 101.</p>
E Q U I P M E N T P E R F O R M A N C E	14	DIAL DIM switch-----	Turn to DIM and FULL, in turn.	Dial lamps behind band-channel and frequency indicator windows should light.	Determine whether any dial lamps are defective. Replace lamps as directed in paragraph 108.
	15	PRESET CHANNELS switch.	Set to positions 1 through 7, in turn.	The operating frequency shown on the frequency indicator for each position conforms to table of assigned frequencies on front panel chart.	Secure locking keys on BAND SELECTOR and/or TUNING CONTROL knob.
	16	PRESET CHANNELS switch.	Set to M (manual) position.		Refer to paragraph 103.
	17	BAND SELECTOR control.	Loosen locking key, and rotate to band available for test purposes.		
	18	TUNING CONTROL---	Loosen locking key and rotate to frequency available for test purposes. The frequency must be within band selected in item No. 17.		

EQUIPMENT PERFORMANCE

Item No.	Item	Action or condition	Normal indication	Corrective measures
19	TEST METER switch..	Turn to PA GRID.....	Grid current should be indicated within shaded area marked PA GRID on test meter M602.	Check plugs J617, P801, J607, and J608 for proper seating. Check contact between spring contactor E605 (fig. 100) and plugs P102 and P203. Check tubes V801, V802, V101, V102, V103, V104, V201, and V601. Refer to paragraph 103. Refer to paragraph 103.
20	BAND SELECTOR control.	Turn to each of ten bands, in turn, and while on each band, turn TUNING CONTROL to low and high end of each band, in turn.	Grid current should be indicated within shaded area on TEST METER.	
21	SERVICE SELECTOR switch.	Turn to CW.....	High voltage dynamotor starts within 10 seconds or less (can be heard).	Replace fuse F603. Refer to paragraph 103.
22	TEST METER switch..	Turn to PA CATH.....	Test meter indicates zero..	Check tubes V202, V406, and V407. Refer to paragraph 102.
23	TEST KEY.....	Hold at ON position.....	After completion of tuning cycle, cathode current should be indicated within shaded area marked PA CATHODE on test meter M602. TUNING INDICATOR lamp lights, 400-cycle sidetone heard in headset.	Defective or poor antenna connection. Check plugs J618, J608, J609, J610, and J611 for proper seating. Check tubes V201, V202, V203, V204, V901, V902, V903, and V904. Refer to paragraph 103. Replace lamp I605 (fig. 102). If using Antenna Group AN/GRA-12, change length of antenna slightly. Check headset and cord. Check plug P401 (fig. 89) for proper seating. Check tubes V401 and V403. Adjust SIDETONE control for greater volume. Refer to paragraph 103. Refer to paragraph 103.
24	BAND SELECTOR control.	Turn to each of the 10 bands. Hold TEST KEY at ON after each frequency setting. Always adjust TUNING CONTROL to bring frequency within the band selected.	Same as for item 23; wait until each tuning cycle is completed for each frequency setting before proceeding with the next one.	
25	SERVICE SELECTOR switch.	Turn to STAND BY.....	High and low voltage dynamotors stop.	Refer to paragraph 103.

	Item No.	Item	Action or condition	Normal indication	Corrective measures
EQUIPMENT PERFORMANCE	26	SERVICE SELECTOR switch.	Turn to VOICE, press button on hand microphone, and speak in a normal voice into microphone (hold about 2 in. from lips).	Cathode current should be indicated within shaded area marked PA CATHODE on test meter M602, and indication should fluctuate slightly while speaking. Voice peaks produce 80 percent or -2 VU indication on audio level meter M603.	Check microphone and cord. Check plugs P401, P402, and P403 for proper seating. Check tubes V401, V402, V403, V404, V406, and V407. Turn CLIPPING control to its maximum counterclockwise position and MODULATION control for 90 percent reading on voice peaks. Adjust CLIPPING control so that M603 indicates 80 percent on voice peaks. Refer to paragraph 103.
	27	BAND SELECTOR control.	Release microphone button. Tighten locking bar.	Dynamotors stop.	
	28	TUNING CONTROL	Tighten locking bar.		
	29	PRESET CHANNELS switch.	Depress reminder spring and set switch to any one of seven positions.	Autotune mechanism cycles.	Refer to paragraph 103.
30	SERVICE SELECTOR switch.	Turn to OFF	Dial lamps off. Dynamotors and blowers stop.		

CHAPTER 5

AUXILIARY EQUIPMENT

42. Description of Transmitter Control C-822/GRC-19

a. Remote control of Radio Transmitter T-195/GRC-19 at distances up to 75 feet is provided when the transmitter is used in conjunction with Transmitter Control C-822/GRC-19 (fig. 13) and Electrical Special Purpose Cable Assembly CX-2585/U (fig. 15).

b. Transmitter Control C-822/GRC-19 is a ruggedized, waterproof unit for remote control operation of the transmitter. This remote control unit can turn the transmitter on or off, select the desired type of operation, select one of seven preset frequencies, and indicate when transmitter is ready for use. The remote control unit is secured in place by its two mounting ears, using two structural bolts and nuts. The case is sealed watertight by means of a backplate and a gasket. The backplate can be removed by taking out six flat-



Figure 13. Transmitter Control C-822/GRC-19, front oblique view.

head screws and six lockwashers. Figure 14 shows all the parts contained within the remote control unit.

43. Description of Electrical Special Purpose Cable Assembly CX-2585/U

(fig. 15)

Electrical Special Purpose Cable Assembly CX-2585/U connects the remote control unit to the transmitter. The remote control cable consists of nineteen No. 20 conductors in a rubber-covered copper-braid shield, and is 75 feet long. Each end of the cable terminates in a 19-contact, male, 90° angle, waterproof connector, Amphenol type 164-21FS.

44. Connections

All receptacles for interconnection purposes are located on the two sides of the remote control unit (fig. 14). Receptacle J701 provides connection for the remote control cable to Radio Transmitter T-195/GRC-19. Receptacles J702 and J703 are similar in function to the AUDIO receptacle (fig. 9) of the transmitter, in that these receptacles provide connections to a microphone, key, headset, or to fsk equipment. Refer to figure 16, which is a cording diagram of the remote control unit. Receptacle J702 or J703 may be used for connecting the microphone, key handset and/or fsk equipment.

45. Operation From Transmitter Control C-822/GRC-19

All operating controls are located on the front panel (fig. 17) of the remote control unit. The functions of these controls are the same as for similar controls located in the transmitter. The SERVICE SELECTOR switch, S701, can select the desired type of operation for the transmitter such as cw, voice, or fsk and voice. This switch also can turn the transmitter off or switch it to standby operation. To operate from a remote point, turn the transmitter SERVICE SELEC-

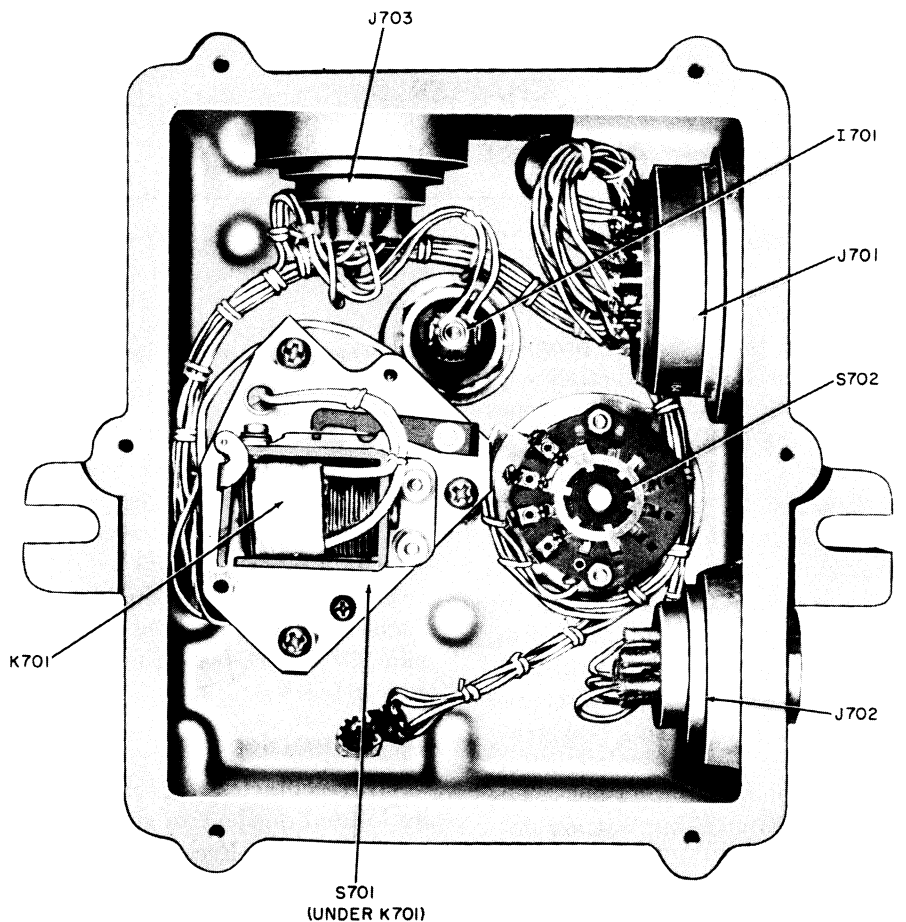

TM 806-16

Figure 14. Transmitter Control C-822/GRC-19 with backplate removed

TOR switch to REMOTE position. The PRESET CHANNELS switch, S702, can select any one of the seven frequencies that had been previously preset at the transmitter. This switch differs from PRESET CHANNELS switch S604 at the transmitter, in that it does not have a manual (or M) position, since there is no provision for manual tuning at the remote control unit. TUNING INDICATOR I 701, like TUNING INDICATOR I 605 at the transmitter, will light whenever the transmitter is tuned.

Note. The VOICE and FSK/VOICE positions of the SERVICE SELECTOR switch of the remote control unit correspond to the VOICE/FSK position of the SERVICE SELECTOR switch on the transmitter.

46. Circuit Description

(fig. 18)

a. Transmitter Control C-822/GRA-19 circuits parallel control circuits contained in Radio Transmitter T-195/GRC-19. A schematic diagram of the remote control unit is given in figure 18 and, in addition, REMOTE CONT receptacle J601, mounted on the front panel of the transmitter, is shown.

b. Receptacle J701 connects to J601 through the remote control cable to complete the following circuits.

- (1) Terminals R of J701 and J601 connect to provide a common ground for both equipments.

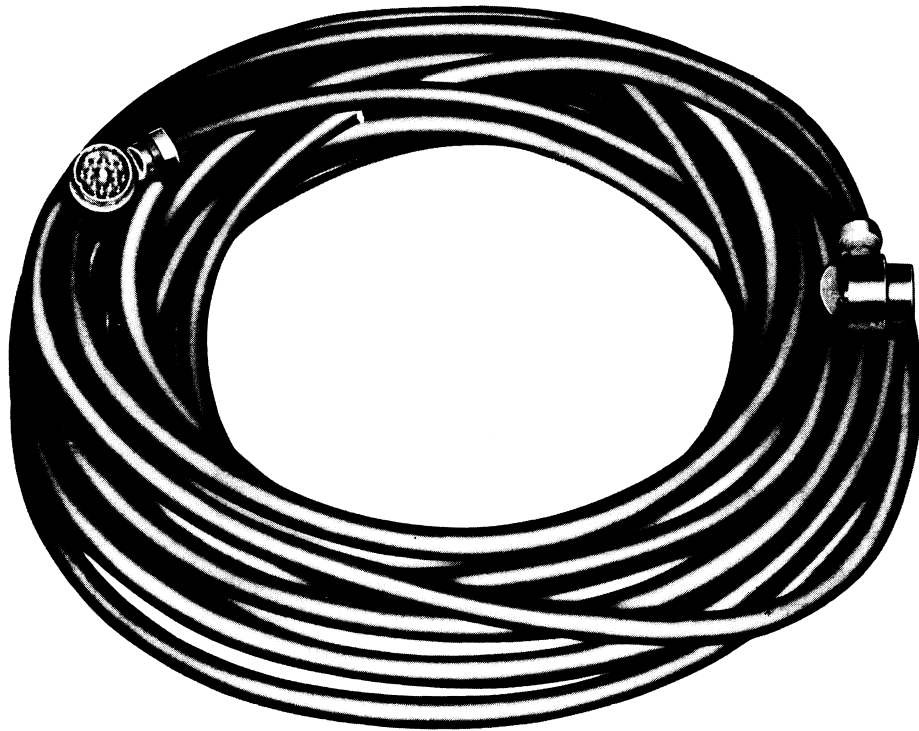

TM 806-17

Figure 15. Electrical Special Purpose Cable Assembly CX-2585/U.

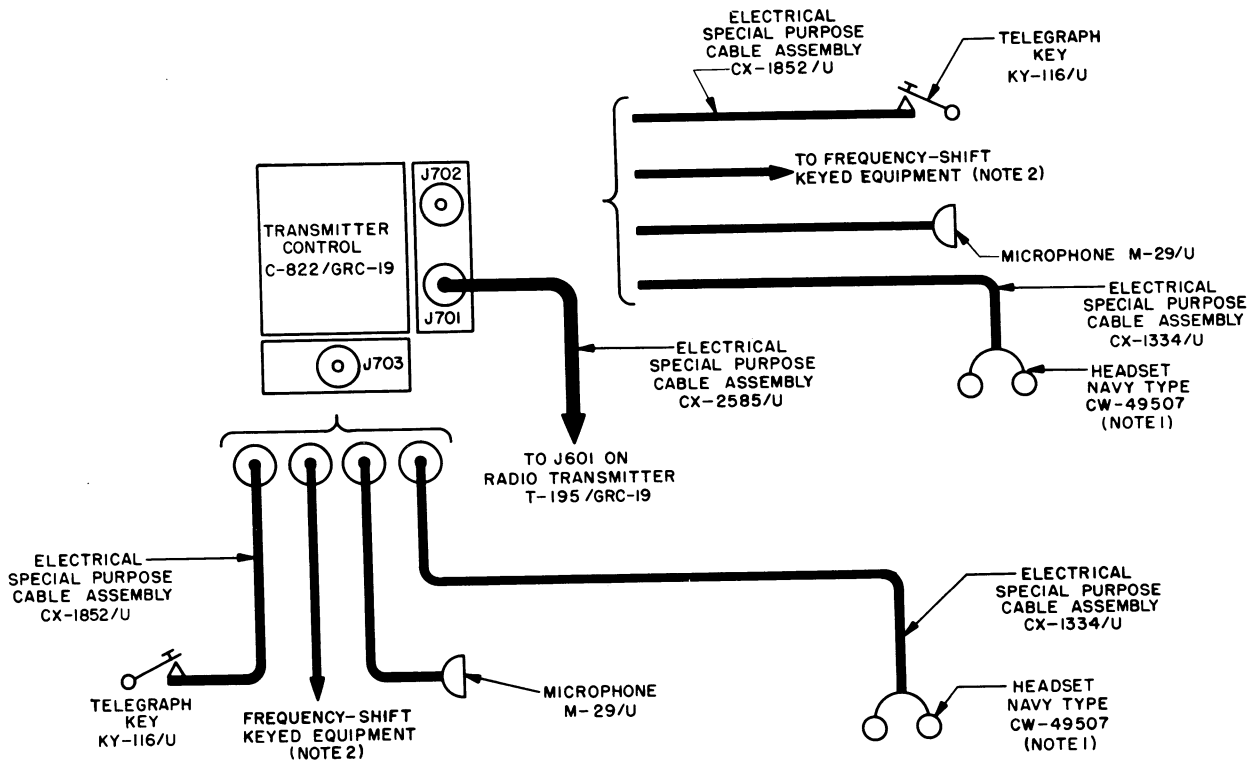

- NOTES:
- HANDSET H-33/PT CAN BE CONNECTED TO **AUDIO** RECEPTACLE J603.
 - NOT FURNISHED WITH RADIO SET AN/GRC-19

TM 806 -18

Figure 16. Transmitter Control C-822/GRC-19, cording diagram.

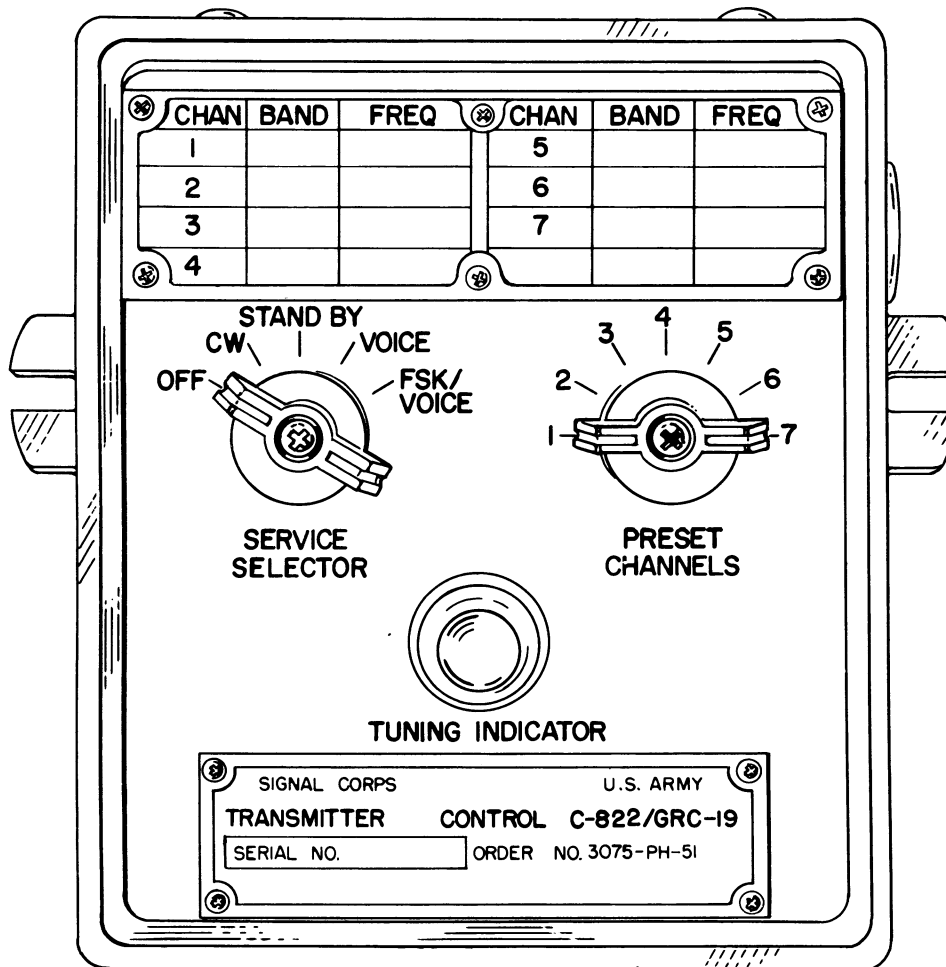

TM 806-19

Figure 17. Transmitter Control C-822/GRC-19, front panel.

- (2) Terminals C of J703 and J702 are connected through J701-B to J601-J, which feeds audio-frequency (af) signals from the microphone to the audio-input circuits of the transmitter.
- (3) Terminals A of J703 and J702 connect a set of headphones through J701-J to J601-B which, when the transmitter is in RELAY or NORMAL operation, provides for monitoring of the transmitter signal.
- (4) Terminals F of J703 and J702 are connected to J701-D which, in turn, connects to J601-F. This completes a grounding circuit to the coil of the keying relay which keys the transmitter when the microphone switch or key is closed.
- (5) Terminal A of J701 connects to J601-K to place the TUNING INDICATOR lamp (1701) in parallel with the indicator lamp in the transmitter.
- (6) Terminals K, L, M, and P of J701 connect to terminals A, W, V, and T of J601 to place the PRESENT CHANNELS switch (S702) in parallel with the PRESET CHANNELS switch in the transmitter. This provides for remote control of the transmitter channel selection circuits. The leads to S702 are disconnected at the transmitter when the transmitter SERVICE SELECTOR switch is moved from its REMOTE position.

- (7) SERVICE SELECTOR switch S701 (front) will connect terminal S of J701 and J601 to ground through contacts 5 and 4 when the switch is moved from its OFF position. This will energize the transmitter filament start relay, which will supply operating voltage to the transmitter. Contact 11 of S701 also is grounded, providing a ground to PRESET CHANNELS switch C702.
- (8) Contact 8 of S701 is connected to ground

through contact 5 when S701 is in the VOICE/FSK position. This completes the voice relay coil circuit in the transmitter, which enables the transmitter audio circuits.

- (9) Contact 9 of S701 is grounded through contact 5 in the VOICE/FSK position, which energizes the transmitter fsk relay.
- (10) When contact 11 of S701 is connected to ground, the (lv) dynamotor in the transmitter is energized (after filament warm-

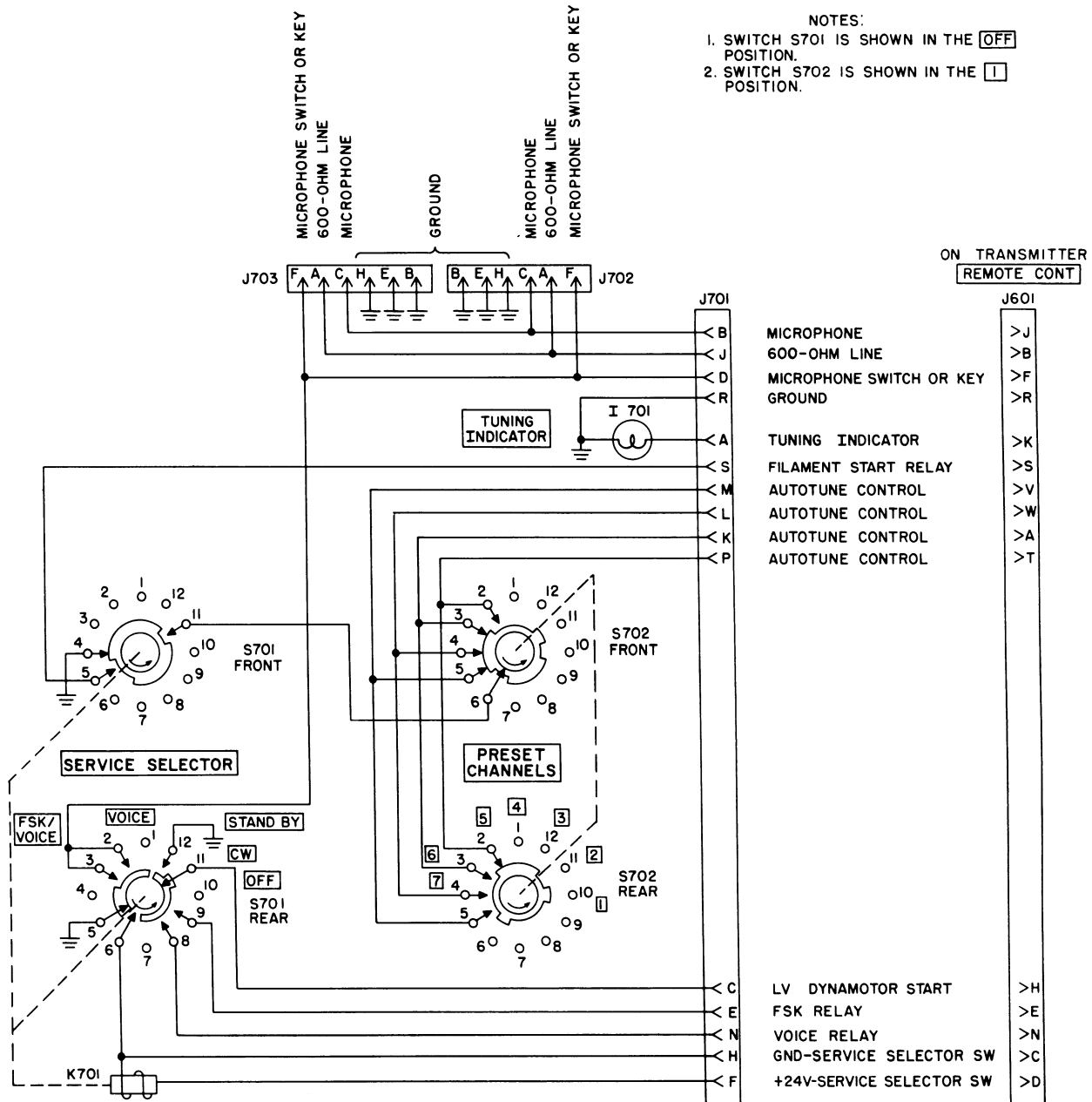

Figure 18. Transmitter Control C-882/GRC-19, schematic diagram.

TM 806-20

up time of 40 seconds). When S701 is in the CW position, contact 11 is grounded through contact 12. When S701 is in the VOICE/FSK position, contact 11 is connected to contact 2 or 3, and the lv dynamotor is energized by closing the microphone switch or key.

47. Maintenance of Transmitter Control C-822/GRC-19

Troubleshooting Transmitter Control C-822/GRC-19 is simplified by the fact that faults which do not appear at the transmitter for identical functions, but do appear at the remote control unit will isolate the trouble to this unit or to the remote control cable. For example, if the TUNING INDICATOR does not light at the remote control unit but lights at the transmitter, then trouble is in the remote control unit circuit. To replace lamp I 701, turn the jewel at the front panel in a counterclockwise direction, remove the jewel, and install a new lamp. If the trouble still remains, check the remote control cable for faulty connec-

tions or wiring. If a good spare cable is available, check by substituting it in place of the old one. This approach can be used to check out the proper functioning of the PRESET CHANNELS and SERVICE SELECTOR switches not only at the remote control unit, but for the same switches at the transmitter. The proper functioning of the transmitter and the interconnecting cabling should be established before sending out the remote control unit for repair. There are no special maintenance techniques for the remote control unit other than those outlined wherever applicable in paragraph 34.

48. Mounting MT-925/GRC-19

This mount is used to secure Radio Transmitter T-195/GRC-19 in a vehicle. The eight shock absorbers protect the transmitter from damage as a result of vibration and impact while in transit. The transmitter is locked in position by the three screw-type devices at the front of the mount. The mount is fastened to the vehicle structure by its base plate, using four screws or bolts and nuts.

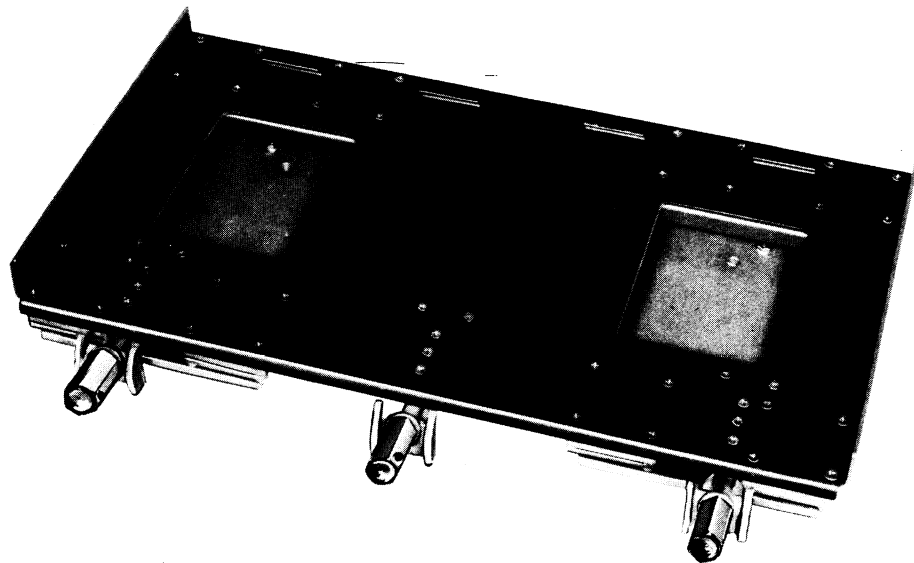

TM 806-7

Figure 19. Mounting MT-925/GRC-19.

CHAPTER 6

THEORY

Section I. INTRODUCTION

49. General

a. Radio Transmitter T-195/GRC-19 is composed of several subchassis that are mounted on the main frame of the transmitter. Each subchassis has a special function, and interconnections are made through multiconductor plugs and jacks. In addition to the subchassis, the antenna output network, Autotune assemblies, two dynamotors, various relay and switching circuits, metering circuits, and various minor component parts are mounted directly onto the main frame and are considered a part of it. The relationships between all subchassis and parts of the main frame are discussed in paragraph 50. Each subchassis or assembly is discussed in detail in paragraphs 51 through 72.

b. In addition to the basic transmitting circuits, the transmitter contains a complex system for automatic tuning and control (pars. 73-86).

50. Block Diagram

(fig. 20)

Figure 20. Radio Transmitter T-195/GRC-19, composite block diagram.

(See Attached Envelope)

a. Signal Circuits.

- (1) The master-oscillator subchassis generates an rf signal within the range of 1.5 to 3 mc. This signal is fed to the exciter subchassis, where it is amplified and frequency-multiplied to the desired transmitting frequency. The output signals of the exciter subchassis, in the range of 1.5 to 20 mc, are fed to the power-amplifier subchassis, which applies power to the transmitter antenna circuit.
- (2) The af signals from the modulator subchassis are applied to the power-amplifier

subchassis to modulate the carrier frequency. The exciter and power-amplifier subchassis normally are inactive, because of bias voltages applied to the grid circuits. When a key or microphone switch is closed, the bias is removed, high voltage (hv) is applied, each subchassis functions to produce its respective output, and power is applied to the antenna circuits of the transmitter.

b. Antenna Tuning Circuits.

- (1) The antenna tuning system is composed of the discriminator, the antenna network servo amplifier, the antenna tuning capacitor, the variable inductor, and the antenna output capacitor. It is used to properly match the impedance of the antenna circuit to that of the power-amplifier output circuit (par. 73).
- (2) The discriminator is composed of two independent circuits: the phasing discriminator that controls impedance matching between antenna and pa stages, and the loading discriminator that controls the resistive load of the antenna. Each circuit produces correction or error voltages that are applied to the antenna network servo amplifier.
- (3) The antenna network servo amplifier is also composed of two sections; one section amplifies the error voltage from the phasing discriminator, the other section amplifies the error voltage from the loading discriminator. The outputs of the two amplifier sections are applied to the antenna tuning capacitor and the variable inductor subchassis. As a result, the capacitance and inductance are adjusted to transform the impedance of the whip antenna or the 50-ohm unbalanced line

to a purely resistive 73 ohms, as required by the power amplifier.

- (4) The antenna output capacitor is composed of a group of fixed capacitors from which can be obtained any one of 10 possible capacitor combinations, depending on the setting of the BAND SELECTOR control. The output capacitor narrows the range over which the antenna tuning circuits must tune.
- (5) An antenna switching circuit connects the antenna to the transmitter during transmission, and to the receiver, through J616, when the transmitter is not being keyed. This arrangement makes possible the use of a single antenna for transmission and reception, without damaging the input circuits of the receiver during transmission.
- (6) Two antenna receptacles are mounted on the front panel of the transmitter: the WHIP ANTENNA receptacle, J615, and the 50 OHMS OUTPUT receptacle, J614. The antenna interlock switch, S613, has an actuating arm on the front panel which covers the coaxial connector, J614. When a 50-ohm antenna is connected to J614, the arm of the switch is moved, connecting J614 to the transmitter output circuit.

c. Frequency Selection Circuits. The frequency range of the exciter subchassis is divided into four bands. The frequency range (1.5–20 mc) of the power-amplifier subchassis is divided into 10 bands. Band selection for the exciter and power-amplifier subchassis is controlled by a single turn Autotune positioning head that is controlled by the Autotune control head for automatic tuning or by a front panel control for manual tuning. Tuning within the band selected is accomplished by use of a multiturn Autotune positioning head that is controlled by the Autotune control head for automatic tuning or by a front panel control for manual tuning. The multiturn positioning head simultaneously positions tuning cores in the master-oscillator and the exciter subchassis so that proper frequency tracking occurs through all bands. The position of the PRESET CHANNELS switch, during automatic tuning, determines the channel or preset frequency to which the Autotune control head will adjust.

d. Power Circuits. Power for the transmitter is supplied by two dynamotors. The high-voltage dynamotor furnishes +1,000 volts to the modulator and power amplifier subchassis, and the low-voltage dynamotor furnishes all other operating voltages except tube filament and control circuit voltages, which are supplied directly from the 24-volt source.

Section II. MASTER-OSCILLATOR STAGES

51. Block Diagram

(fig. 21)

All transmitting frequencies of Radio Transmitter T-195/GRC-19 are multiples (1, 2, 4, and 8) of the frequencies generated by the master oscillator. This subchassis contains two 5749 tubes, V801 and V802.

a. The oscillator tube, V801, is slug tuned, and generates a frequency in the range of 1.5 to 3 mc. Tuning is controlled by the TUNING CONTROL.

b. The buffer-amplifier tube, V802, amplifies the rf signal generated by the oscillator tube before it is fed to the exciter.

52. Oscillator V801

(fig. 22)

a. Oscillator tube V801, type 5749/6BA6W, is connected in a Hartley circuit, with L801 and

L803 serving as the inductive branch of the parallel resonant circuit. C801, C802, C803, and C804, form the inductive branch of the circuit. Frequency variation is possible through movement of a tuning core within L801. This variation is controlled by the TUNING CONTROL. A highly critical, variable-pitch winding, L801, produces a linear frequency variation with core movement; L803 is an inductive trimmer that establishes the exact frequency range of the oscillator.

b. Resistor R801 and capacitor C805 form the grid bias network. Plate and screen-grid voltages are supplied from the +250-volt supply through voltage-dropping resistor R601 and voltage regulator tube V601. The operating voltage of V601 is 150 volts, so that +150 volts, regulated, is supplied through rf choke L802 to screen-grid resistor R802 and plate resistor R803. C806 is the screen

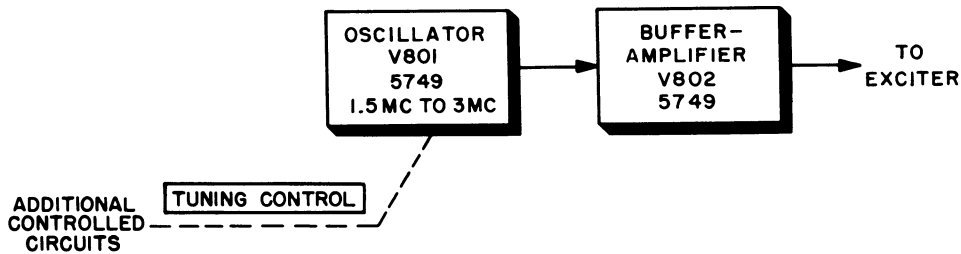

TM 806-22

Figure 21. Master oscillator, block diagram.

voltage rf bypass. C810 is an rf filter for the +150-volt supply.

c. The oscillator tube produces an rf signal in the frequency range of 1.5 to 3 mc, depending on the setting of the TUNING CONTROL. The output of V801 is fed to the control grid of buffer amplifier V802 through coupling capacitor C807.

53. Buffer Amplifier

(fig. 22)

Buffer amplifier V802, type 5749/6BA6W, amplifies the signal generated by oscillator V801. Self-bias for the tube is developed across R804. Between transmissions, when K605 is deenergized, the tube is biased to cutoff by the negative bias applied through R448 and R453 to the suppressor grid. During transmission, K605 is energized and

the negative bias is grounded through contacts 4 and 5 of K605. When the biasing voltage is removed, V802 operates in a normal manner and supplies a signal to the exciter. Plate voltage is applied through R806. The screen grid circuit consists of R805 and C808. Capacitor C811 is an rf filter for the -45-volt supply. The output signal is applied to the exciter through C809, P801, and J101.

54. Oscillator Frequency Stabilization

(fig. 61)

Figure 61. +24-volt distribution, functional diagram.

(See Attached Envelope)

Compensation for low-temperature operation is provided by a noninductive heater winding

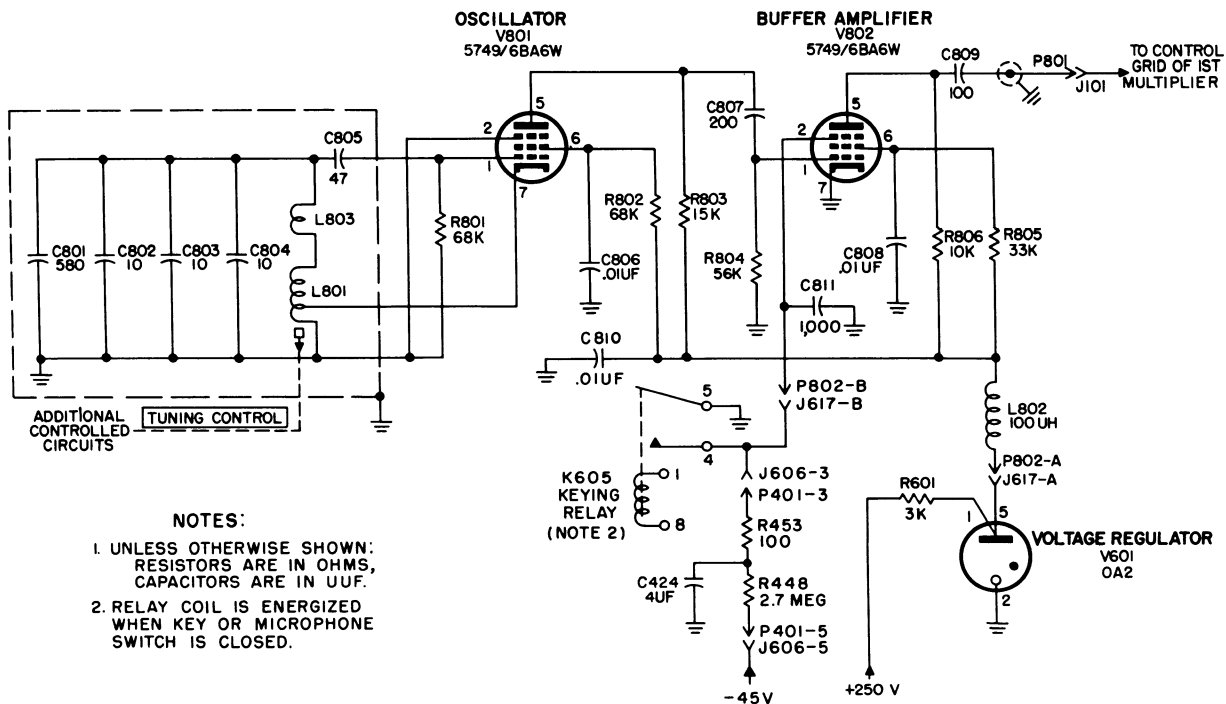

NOTES:

1. UNLESS OTHERWISE SHOWN: RESISTORS ARE IN OHMS, CAPACITORS ARE IN UUF.
2. RELAY COIL IS ENERGIZED WHEN KEY OR MICROPHONE SWITCH IS CLOSED.

Figure 22. Master-oscillator stages, functional diagram.

TM 806-23

wrapped around the outside of the oscillator can. Thermostat S801, mounted on one end of the can, has a set of contacts in series with the noninductive heater winding. C812 is a spark-suppressing capacitor. When the ambient temperature falls below 0° C. (32° F.) one of the contacts, which is mounted on a bimetallic strip, moves into contact

with the stationary contact and applies 24 volts dc to the heater element. Power is continuously supplied to the heater element until the temperature at the thermostat rises above 0° C. (32° F.). The oscillator is provided also with a metal shield for preventing extraneous magnetic fields from upsetting the frequency setting.

Section III. EXCITER

55. Block Diagram

(fig. 23)

The exciter is used to amplify the output of the master oscillator and to furnish the desired transmitting frequency to be applied to the power amplifier.

a. The exciter can be set to operate at one of four possible frequency ranges with BAND SELECTOR control S101. The switch selects the proper combination of circuit components in the exciter to provide the desired transmitting frequency band. Tuning through each band is accomplished by using tuning cores in the interstage tuned circuits, which are controlled by the TUNING CONTROL.

b. The block diagram of figure 23 shows the tubes and tuned circuits used for each band.

- (1) The conditions set up for the 1.5- to 3-mc range are shown in A, figure 23. The master-oscillator output is applied to first multiplier tube V101, which amplifies the signal. The output of V101 is fed to driver tube V104, through S101F (rear) and S101D (rear). The driver tube amplifies the signal before it is applied to Z107 and then to the power amplifier.
- (2) In B, figure 23, the exciter is shown with the BAND SELECTOR control set to the 3- to 6-mc band. The first multiplier introduces harmonic frequencies into the output signal. The output of V101 is applied through S101F (rear) to tuned circuits Z101 and Z102, which resonate at the harmonic frequency to which they are tuned. This frequency is in the 3- to 6-mc range, depending on the setting of the TUNING CONTROL. The output of these circuits is applied through S101F (front) and S101D (rear) to driver tube V104, which amplifies the

signal. The signal then is applied to Z108 through S101A.

- (3) In C, figure 23, the exciter is shown with the BAND SELECTOR control S101 set to the 6- to 12-mc range. The operation of the circuit is the same as for the 3- to 6-mc range, except that the output of Z101 and Z102 is applied through S101F (front) to second multiplier tube V102. The frequency of the signal applied to V102 is twice that of the master-oscillator signal. Tube V102 generates harmonic frequencies. The signal then passes the resonant circuits of Z103 and Z104, which are tuned in the 6- to 12-mc range. The output of this circuit then is applied through the band switch to the driver tube, then through Z109.
- (4) In D, figure 23, the exciter circuit is shown with the band switch set for the 12- to 20-mc range. The circuit operation is the same as that given in (3) above, except that the output of the tuned circuits of Z103 and Z104 (6-12 mc) is applied through S101E (rear) to third multiplier tube V103 instead of to V104. Tube V103 causes harmonics to appear in the output signal, which is fed to tuned circuits Z105 and Z106. These circuits are tuned to resonate in the range of 12 to 20 mc. The output of Z105 and Z106 is applied to the driver tube through S101D (rear), where it is amplified and applied to the output circuit of the exciter through Z110.

56. First Multiplier V101

(fig. 24)

The first multiplier uses a miniature pentode tube, type 6AU6WA, to amplify the master-oscillator signals and to generate harmonics in its output circuit.

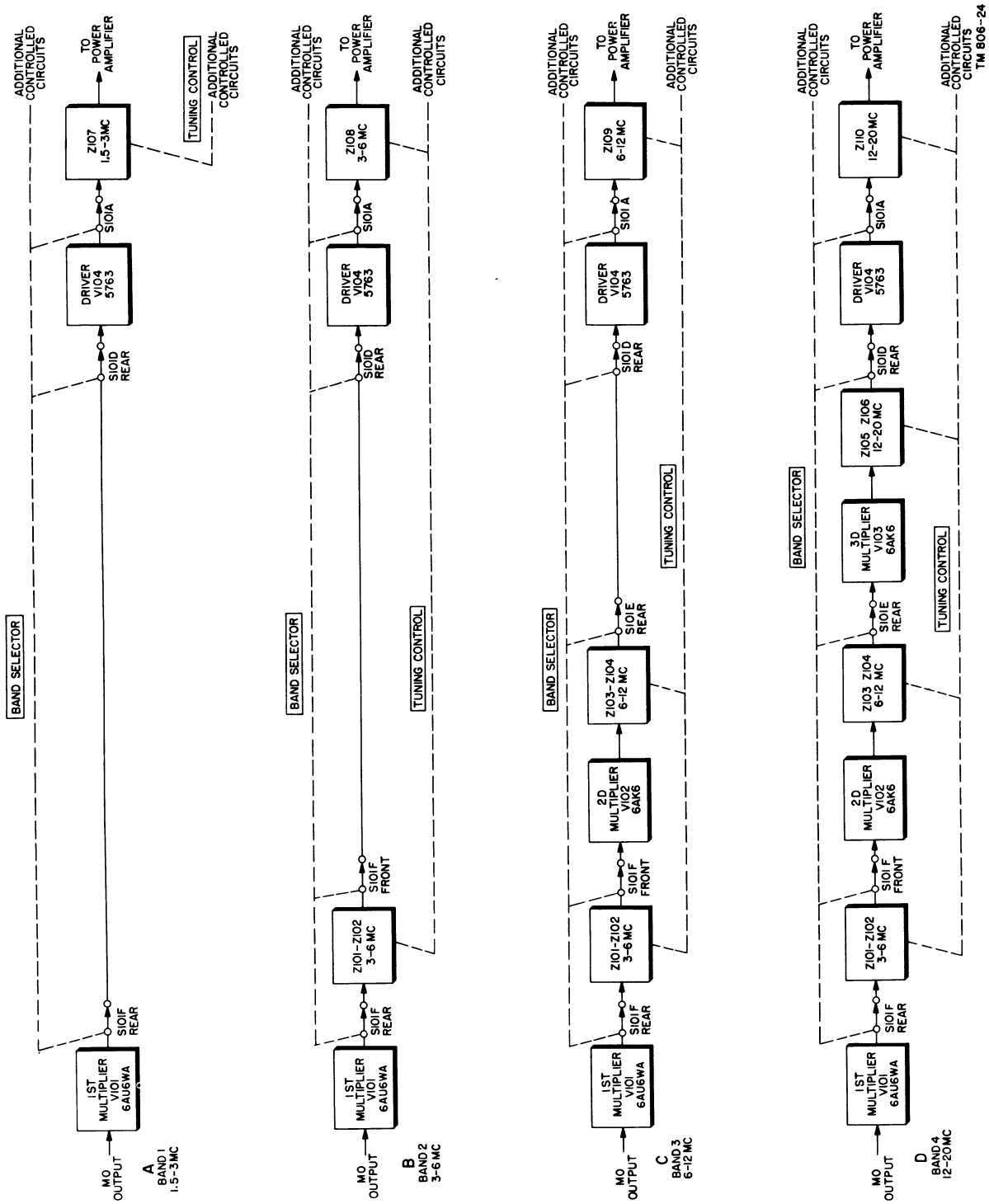

Figure 23. Exciter, block diagram.

TM 806-24

a. The output of the master oscillator is fed through P801, J101, and coupling capacitor C101 to the control grid of first multiplier tube V101. Frequency-shift operation is made possible by the frequency-shift input circuit, consisting of J613, P601, J102, R122, and L111, through which a signal from an external frequency-shift exciter is applied to the grid circuit of V101. A small amount of grid bias is generated across R101 and R120, but the major source of bias is from the -45-volt keying supply through R119, so that the plate current of V101 is completely cut off when the key or microphone switch is open. When the key or microphone switch is closed, grid bias is generated in the normal manner; fixed bias is grounded through contacts 6 and 7 of keying relay K605. C102 and C134 bypass the control grid return of V101 and also provide a small amount of wave shaping for the keying bias.

b. R102 and C103 provide cathode bias. Screen potential is supplied through R103, with C104 acting as the screen bypass capacitor. C146 decouples V101 plate circuit from the power supply.

c. The position of S101F (rear) selects one of two possible plate circuits for V101. For band 1 (1.5-3 mc.), plate voltage is supplied through R105, and the output signal is applied to the control grid of driver tube V104, through coupling capacitor V106 and S101D (rear). For bands 2, 3, and 4, plate voltage is fed through L101, which, with C107 and C108, form the plate load for V101. This circuit (Z101) is tuned to the second harmonic of the master-oscillator frequency, and is tunable through the range of 3 to 6 mc. Frequency tracking is accomplished by means of the tuning core of L101, which is moved simultaneously with the tuning core in the tuned circuit of oscillator tube V801. C107 is a trimmer capacitor; it is used to obtain more accurate frequency tracking.

d. Capacitor C109 couples Z101 to Z102. Tuned circuit Z102 is composed of L102, fixed capacitor C110, and variable capacitor C111; its circuit action is identical with that of Z101. Capacitors C112 and C113 couple neutralizing voltage from exciter output stage V104 (par. 60*d*). The 3- to 6-mc output of Z102 is applied to the grid circuit of V104, for band 2, through S101D (rear), or to the grid of second multiplier tube V102, for bands 3 and 4, depending on the position of S101F (front).

57. Second Multiplier V102

(fig. 25)

The second multiplier uses a miniature pentode, type 6AK6, to amplify the signal from the multiplier and to generate harmonic frequencies of the signal.

a. When BAND SELECTOR control S101 is positioned to band 3 or 4, rf excitation in the range of 3 to 6 mc is applied to the control grid of V102. Grid bias is generated across R106, which, together with the cathode bias produced across R107, establishes the desired operating point for second multiplier V102. Capacitor C114 duplicates the input capacity of the driver stage (V104) so that Z102 is tuned regardless of band selection. C115 bypasses rf voltage around R107. Plate and screen voltage is applied to V102 from the +250-volt supply and is decoupled by C146. Plate current flow is through L103.

b. The tuned circuit of Z103, consisting of variable capacitor C118, fixed capacitor C119, and L103, is in the plate circuit of V102 and is coupled to Z104 through C120. Z104 consists of L104, fixed capacitor C121, and variable capacitor C122. Capacitors C123 and C124 form a network to couple the neutralizing voltage (par. 60).

c. The operation of Z103 and Z104 is similar to that of Z101 and Z102, except that they are tuned for a 6- to 12-mc range, and resonate at the second harmonic of the signal applied to the grid of V102. Because the tuned circuits of V101 double the frequency of the master oscillator, the frequency at which Z103 and Z104 resonate is four times that of the oscillator. The output of Z104 is applied to the driver tube, V104, through S101E (rear) and S101D (rear), or to the grid of V103, depending on the position of the BAND SELECTOR control.

58. Third Multiplier V103

(fig. 26)

The third multiplier uses a miniature pentode, type 6AK6, to amplify the signal from the second multiplier, and to cause harmonic frequencies of the signal to appear in its output.

a. If BAND SELECTOR control S101 is positioned to band 4, the rf excitation is applied to the control grid of V103, through S101E (rear). This develops bias voltage across R110. Capacitor C125 duplicates input capacity at V104 so that Z102 will remain tuned, regardless of band selec-

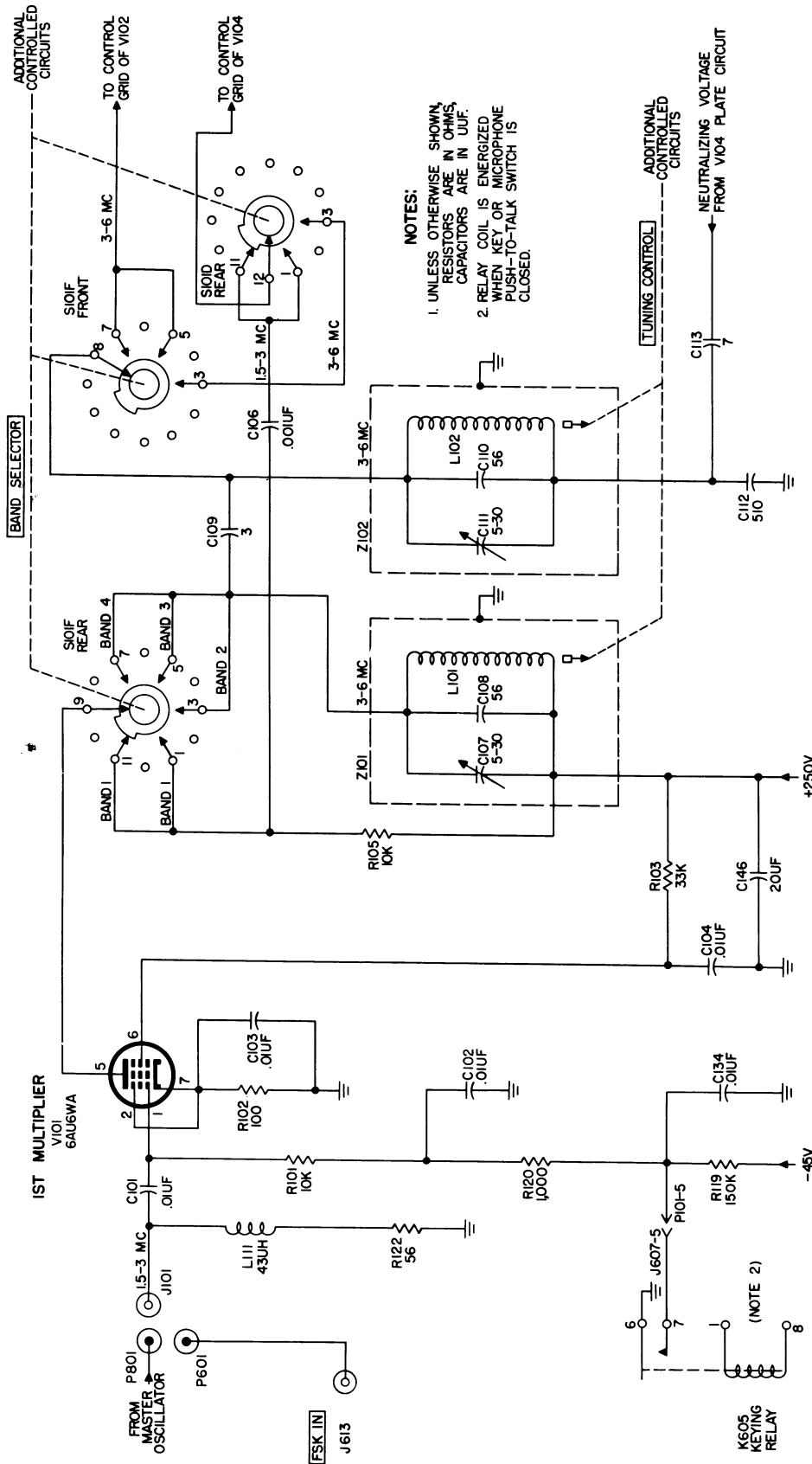

Figure 24. First multiplier stage, functional diagram.

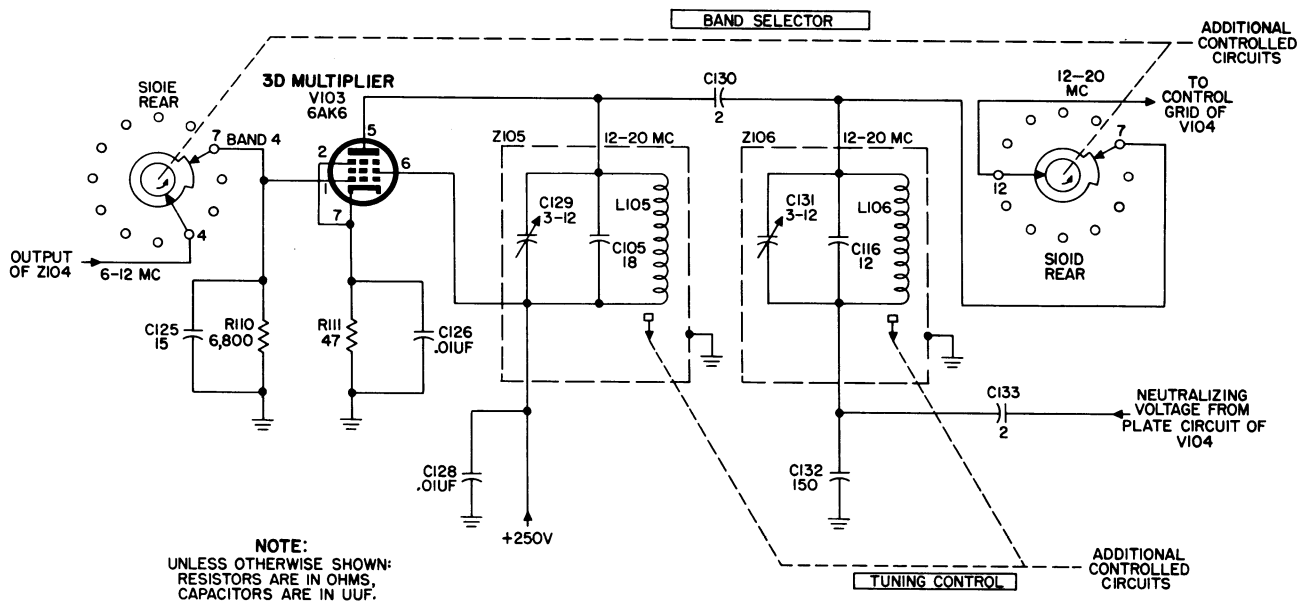

Figure 26. Third multiplier stage, functional diagram.

TM 806-27

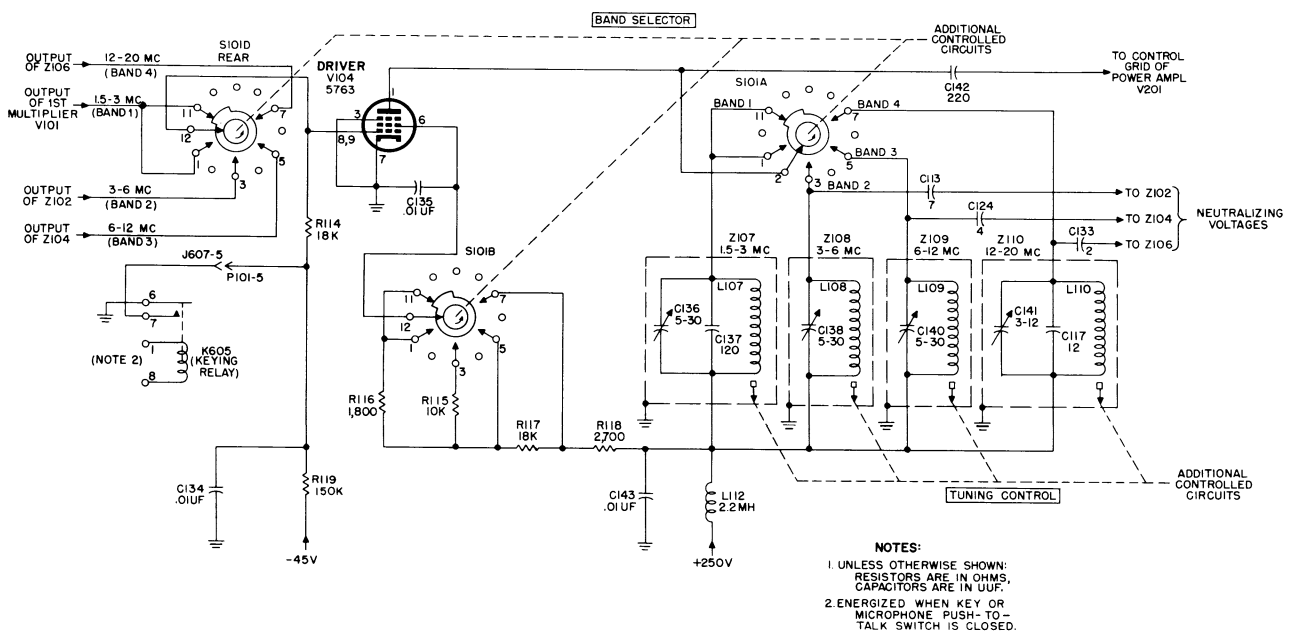

Figure 27. Driver stage, functional diagram.

TM 806-28

bands, is fed through C142 to the grid circuit of power amplifier V201.

Exciter band	Tuned circuit	Frequency range (mc)
1	Z107	1.5 to 3.
2	Z108	3 to 6.
3	Z109	6 to 12.
4	Z110	12 to 20.

60. Exciter Neutralization

Neutralization is provided for bands 2, 3, and 4 in the exciter to compensate for grid-to-plate

capacitance in V104. Figure 28 shows the neutralizing circuit for band 2 (3-6 mc), which is comparable to the circuits for bands 3 and 4. This 3- to 6-mc output signal of Z101 is applied through C109 to the grid circuit (Z102) of the driver tube. Internal feed-back voltage (plate to grid) of V104, which may cause undesirable oscillations in Z102, is canceled by application of an external feed-back voltage from the plate of V104, through the voltage divider composed of C112 and C113, to the tuned circuit. Because this feed-back voltage is 180° out of phase with the internal feed-back voltage, cancellation of the undesirable voltages occurs.

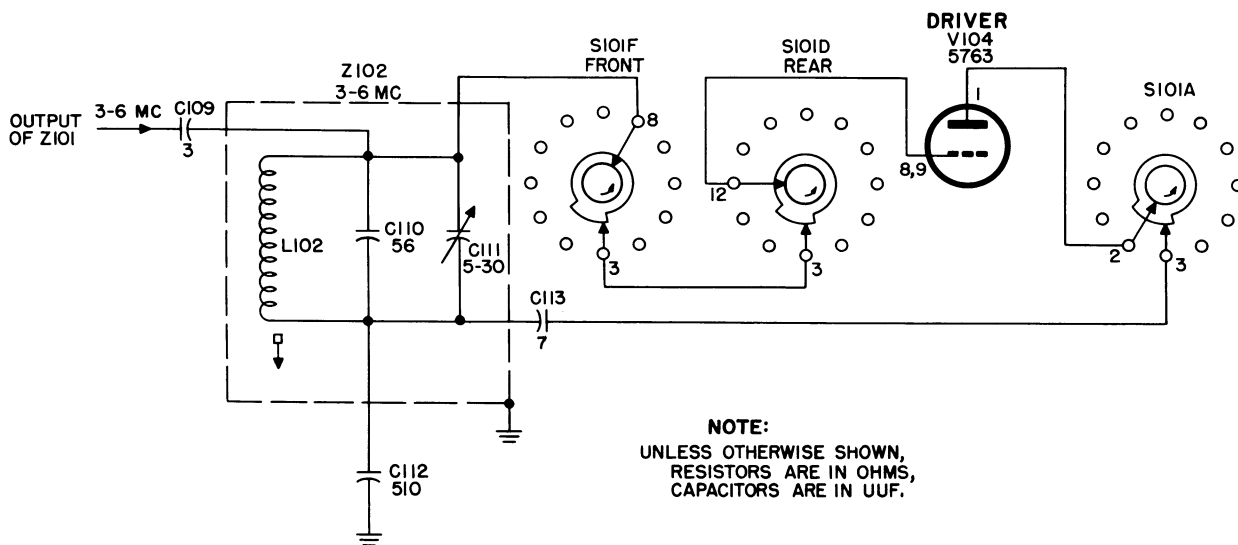

TM 806-29

Figure 28. Neutralization circuit, functional diagram.

Section IV. POWER-AMPLIFIER STAGES

61. Block Diagram (fig. 29)

The power amplifier operates on one of the 10 bands, the selection of which is determined by the BAND SELECTOR. The power-amplifier subchassis contains, in addition to the power-amplifier tube, a protective current-limiting circuit (clammer stage) and a servo system for tuning the pa output circuits.

a. The exciter output signal is applied to the power-amplifier tube, V201, where it is amplified to provide the proper transmitter power output. The output of V201 is fed through L204 to the antenna system.

b. The BAND SELECTOR selects the proper

combination of inductors and capacitors that are used in the pa output circuit for the operating band in use. Chokes L202 and L204 are tapped so that sections of the coils are shorted out for certain frequency bands. Each of the variable capacitors, C221 and C222, is composed of two sections, and one or both of these sections are used, depending on the operating band in use. Fixed capacitors C214 through C220, and C223, C224, and C226 through C232, are switched in or out of the circuit, as required.

c. The af signals from the modulator subchassis are applied through L202 and L203 to the plate circuit of the pa tube, and thereby modulate the amplified carrier frequency.

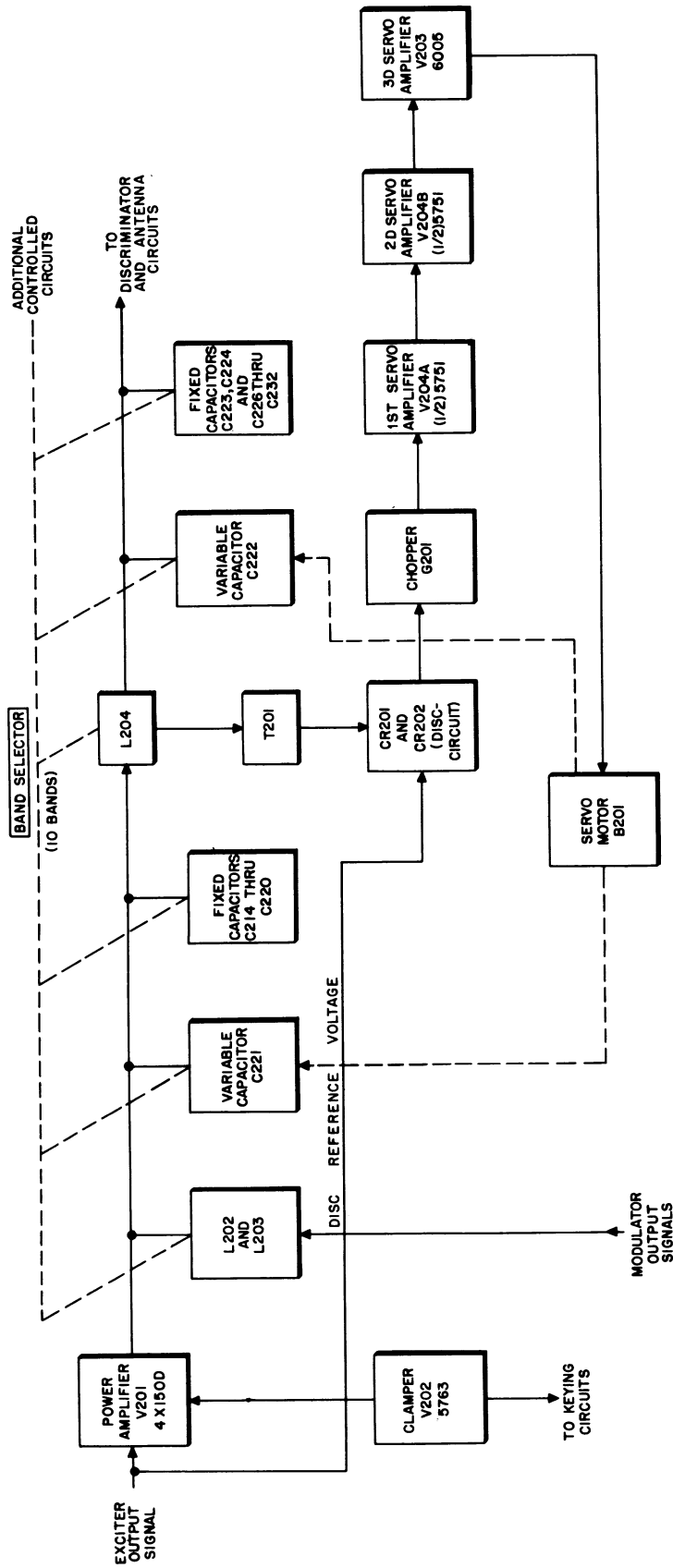

TM806-30

Figure 29. Power amplifier, block diagram.

d. Coil L204 is inductively coupled to T201, which samples the power-amplifier output and applies a signal to the discriminator circuit composed of CR201 and CR202. The purpose of the discriminator is to detect a phase shift between the power-amplifier plate and grid voltages and to convert this difference to a dc error voltage. Error voltage will increase or decrease proportionately as the amount of phase shift varies.

e. The dc error voltage is applied to the chopper, G201, where it is converted to a square wave voltage. The output of G201 then is fed to the amplifier section, composed of V204A, V204B, and V203, the output of which is used to rotate servo motor B201; this causes variable capacitors C221 and C222 to vary as required to tune the output circuit of the power amplifier.

f. The clamper, V202, controls the screen voltage of the power-amplifier tube, so that excessive current will not be drawn and damage the tube or its associated circuits when rf voltage is not being furnished by the exciter subchassis.

62. Power Amplifier V201

(fig. 30)

Figure 30. Power-amplifier and clamper stages functional diagram.

(See Attached Envelope)

This stage is a class C amplifier, the circuit of which is shown in figure 30.

a. The grid circuit of V201 contains L201 and C201, which filter rf from the dc circuits of the power supplies and meter M602. Fixed negative bias is obtained from the voltage divider, composed of resistors R204, R232, R203, R612, and R624. This voltage divider is connected between the +250-volt source and the -45-volt source. Resistor R627 furnishes a ground return for grid-leak bias of V201. When TEST METER switch S607 is set to the PA GRID position, the meter leads of M602 are connected through S607 and across R612 to measure the grid current of V201 during transmission. R618 serves as a current-limiting resistor for the meter. A voltage is taken from the control grid of V201 for use in the pa tuning discriminator circuit (par. 64).

b. The cathode of V201 is connected to ground through part of the heater winding of K202 and meter shunt resistor R613. When TEST METER switch S607 is set to the PA CATH position, meter M602 is connected in parallel with R613 through contacts 11 and 8 of S607, with the negative side

of the meter connected to ground through contacts 2 and 5. Meter M602 indicates current drawn by the cathode of V201. Capacitor C247 bypasses rf to ground. Should excessive plate current be drawn by V201, thermal overload relay K202 opens and removes the shunt across the second half of the heater winding and R236. These added resistances, between the cathode of V201 and ground, increase the cathode bias of V201. The increased cathode bias reduces the current flow through V201 to a safe value and prevents damage to V201 and its associated circuits. The additional heater winding will keep K202 open until the transmitter is turned off for a few seconds.

c. The screen grid of the pa tube is connected through voltage dropping resistors R228, R224, and R202, to the +1,000-volt supply. Rf filtering is provided by capacitors C204, C247, and C203.

d. In the VOICE/FSK position of SERVICE SELECTOR switch S606, the coil of transformer shorting relay K203 is energized by completing the coil circuit to ground through contacts 5 and 4 of the switch. This opens the normally closed contacts of the relay, and +1,000 volts, and the af output of the modulator subchassis is applied through rf chokes L202 and L203, and through parasitic suppressor E201 to the plate of V201. In the CW position of S606, the coil circuit of K203 is open, and the contacts of the relay close to short out the secondary winding of T402; this prevents stray af signals from being applied to the plate circuit of the power amplifier. In this condition, the plate voltage is supplied directly from the +1,000-volt supply and through the closed contacts of K203 to the plate circuit of V201. Rf bypass capacitors C202, C250, and C251 prevent rf voltages from feeding back into the power source. Provision is made to short out rf choke L202 at the higher operating frequencies to prevent self-resonance. In figure 30 BAND SELECTOR switch S201B is positioned for the 1.5- to 1.7-mc range. In this position, and in the next four operating bands (1.7-4 mc), L202 is connected in the plate circuit of V201. At the five higher bands (4-20 mc), contacts 12 through 16 are connected to the stationary bar of the switch, and L202 is short-circuited. For bands 8 and 9 (9-16 mc), a center tap of L202 is additionally shorted to each end of the coil. Coupling capacitor C205 feeds the output of V201 to the power-amplifier output circuits.

63. Clamper V202

(fig. 30)

Figure 30. Power-amplifier and clamper stages, functional diagram.

(See Attached Envelope)

A pentode, tube type 5763, is used for the clamping stage, to reduce the screen voltage of V201 to a safe value of plate current when the keying circuit is open.

a. The control grid of V202 is biased by grid current through R229 when keying relay K605 is not energized, and allows the tube to conduct. When K605 is energized, a negative voltage is applied from the junction of R203 and R204, through contacts 2 and 3 of K605, contacts 4 and 3 of K615, and the normally closed contacts of S203 to the control grid of V202. This causes the clamper tube to become nonconductive. The cathode and suppressor grid of V202 are connected directly to ground, and the screen grid and plate of V202 are tied together and connected to the screen grid of power amplifier V201. When keying relay K605 is not energized, thus allowing V202 to conduct, a reduced voltage is applied to the screen grid of power amplifier V201, and the plate current of V201 is lowered.

b. Wave shaping at the plate of V201 is controlled by C208 and R229, which, because of the time required to charge or discharge C208 through R229, prevents an abrupt change in the screen-grid potential of V201. During keying, when K605 is energized, the negative bias applied to the control grid of V202 drives the clamper to cutoff, thereby increasing the screen grid voltage of V201. The keying relay, when energized, also causes rf excitation to be present at the control grid of the power amplifier, and full carrier appears at the output of the transmitter. The normally closed contacts of S203 will open momentarily during band switch to prevent keying of the transmitter when the BAND SELECTOR is improperly positioned.

64. Power-Amplifier Tuning

(fig. 31)

Figure 31. Power-amplifier plate circuit, functional diagram.

(See Attached Envelope)

The tuning circuits of the power amplifier tune the plate circuit of V201 to resonance at the selected frequency. The phase relationship of

plate and grid voltages is utilized in the pa tuning circuits to adjust variable capacitors C221 and C222 so that the plate circuit of V201 will be tuned to the output frequency.

a. *Power-Amplifier Plate Circuit* (fig. 31). The plate circuit of V201 consists of variable capacitors C221 and C222, plate inductor L204, and fixed capacitors C214 through C220, and C223 through C232. When the BAND SELECTOR switch is operated to select a new operating band, S201A selects the desired value of capacitance from fixed capacitors C214 through C220 and variable capacitor C221. S201D selects the proper value of inductance from tapped coil L204, decreasing inductance as frequency is increased. S201C provides an additional short circuit for sections of L204 to prevent spurious resonant conditions in the unused portions of the coil. The desired value of output capacitance is selected by S201E (front and rear). This switch selects fixed capacitors C223, C224, and C226 through C232 as well as variable capacitors C222A and C222B, as required on each band. Capacitor C225 is in the circuit for all bands. Transmitter bands are as follows: 1.5 to 1.7 mc, 1.7 to 2.0 mc, 2.0 to 2.4 mc, 2.4 to 3.0 mc, 3.0 to 4.0 mc, 4.0 to 6.0 mc, 6.0 to 9.0 mc, 9.0 to 12.0 mc, 12.0 to 16.0 mc, and 16.0 to 20.0 mc. Tuning through the range of variable capacitors C221 and C222 is controlled by servo motor B201 (b, c, and d below). L205 provides a dc path to ground (par. 77c).

b. *Pa Discriminator Circuit* (figs. 32 and 33). Tuning within the band selected is accomplished by using a servo tuning circuit, of which the discriminator circuit is a part. Discriminator action is accomplished as follows:

- (1) The pa discriminator compares the phase relationship of the V201 output voltage with reference voltage. Any change in the phase relationship between the two voltages causes the discriminator to develop an error voltage. This error voltage is used to adjust the phase relationship to the original condition.
- (2) The output of V201 is connected to L204 through parasitic suppressor E201 and dc blocking capacitor C205. T201 is a coil that inductively couples a portion of the V201 rf output to the discriminator. R206 and R207 are the loading resistors for T201. L207 is placed in parallel with R201 in order to improve the pa tuning

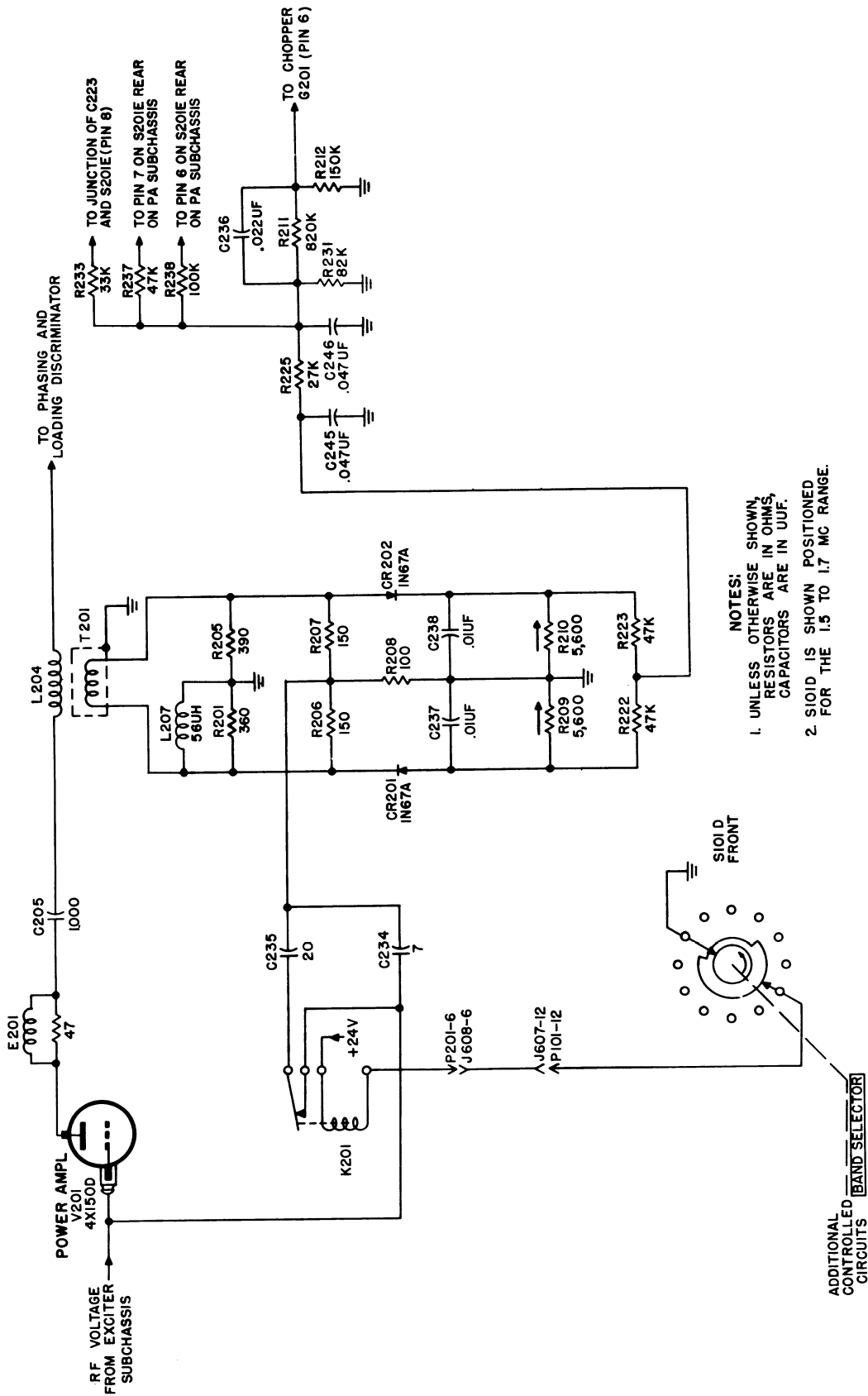

TM 806-33

Figure 32. Power-amplifier discriminator circuits, functional diagram.

accuracy at low frequencies. R201 and R205 are balancing resistors to ground for each end of T201. CR201 and CR202 are crystal diode rectifiers. C237 and C238 remove rf from the rectified output, thereby providing a steady dc voltage to the chopper. Resistors R209 and R210 are the load resistors for the rectifiers across which the output voltages are developed. R222 and R223 couple the discriminator output voltages into the low-pass filter composed of C245, R225, and C246. C236, R211, and R212 are used to improve the servo response time and to eliminate hunting of the servo. Resistors R238, R237, and R233 reduce the servo gain to improve the servo loop stability when operating on bands 8, 9, and 10 respectively.

- (3) The reference voltage is obtained by use of the phase-shifting circuit, composed of C234 and C235, that is connected between the grid of V201 and load resistor R208. Since capacitive reactance is greater at lower frequencies, compensation is provided to obtain a more uniform phase shift between current and voltage through the entire range of operating frequencies. By adding the capacitance of C235 in parallel with that of C234 at the six lower frequency bands, the capacitive reactance is decreased through the phase-shifting circuit. In figure 32, the BAND SELECTOR switch S101D (front) is shown positioned for the 1.5- to 1.7-mc band. In this band and the next five operating bands (1.7-6 mc), the switch completes the coil circuit of K201, which closes the relay contacts and thus adds C235 to the circuit. For the four higher frequency bands, the ground circuit through the S101D (front) is broken, de-energizing K201, which removes C235 from the circuit. The current through the capacitors will lead the rf excitation voltage by approximately 90° , causing a voltage to appear across R208 which leads the grid excitation voltage by 90° .
- (4) At resonance, the plate voltage, E_p , and the plate current, I_p , are in phase. Since L204 is in an inductive branch of the output circuit (fig. 42), current I_L , through

L204, lags E_p by 90° . I_L induces in T201 a voltage E_s which lags I_L by 90° . A, figure 33, shows the phase relationship between E_s , I_L , and E_p .

- (5) The reference voltage, E_c , is 180° out of phase with the plate voltage before it is shifted. As explained in (3) above, the reference voltage is shifted ahead 90° ; therefore, the reference voltage, E_c , and E_s are 90° out of phase (A, fig. 33).
- (6) Since R206 and R207 are of equal value, voltage across each, E_{R206} and E_{R207} , is equal and is one-half of E_s . With respect to the center tap of R206 and R207, the voltages are 180° out of phase with each other (B, fig. 33). Voltage E_{CR202} applied to CR202, is equal to the vector sum E_c and E_{R207} . B, figure 33 shows the phase relationship of the voltages. Rectified current flow through R209 and R210 will be in the direction indicated by the arrows in figure 32. When the voltages applied to CR201 and CR202 are equal, equal currents flow through R209 and R210. This results in voltage drops across R209 and R210 which are equal in magnitude but of opposite polarity with respect to their grounded center tap; therefore, no error voltage appears at the center tap of R222 and R223.
- (7) Above resonance, the plate circuit becomes capacitive and the current leads the voltage. The current I_L , through L204, and the induced voltage E_s will also be advanced from their phases at resonance. The reference voltage, E_c , will not change in phase. Addition of the two voltages that are applied across CR201 and CR202 results in E_{CR201} and E_{CR202} (C and D, figure 33). Since E_{CR201} is larger than E_{CR202} , a greater voltage will be developed across R209 than across R210. This results in a negative voltage equal to half the difference of the two voltages being coupled out of the discriminator.
- (8) The development of the discriminator voltages for frequencies above resonance (E and F, fig. 33) results in a positive voltage equal to half the difference of the two voltages being coupled from the discriminator. This error voltage is am-

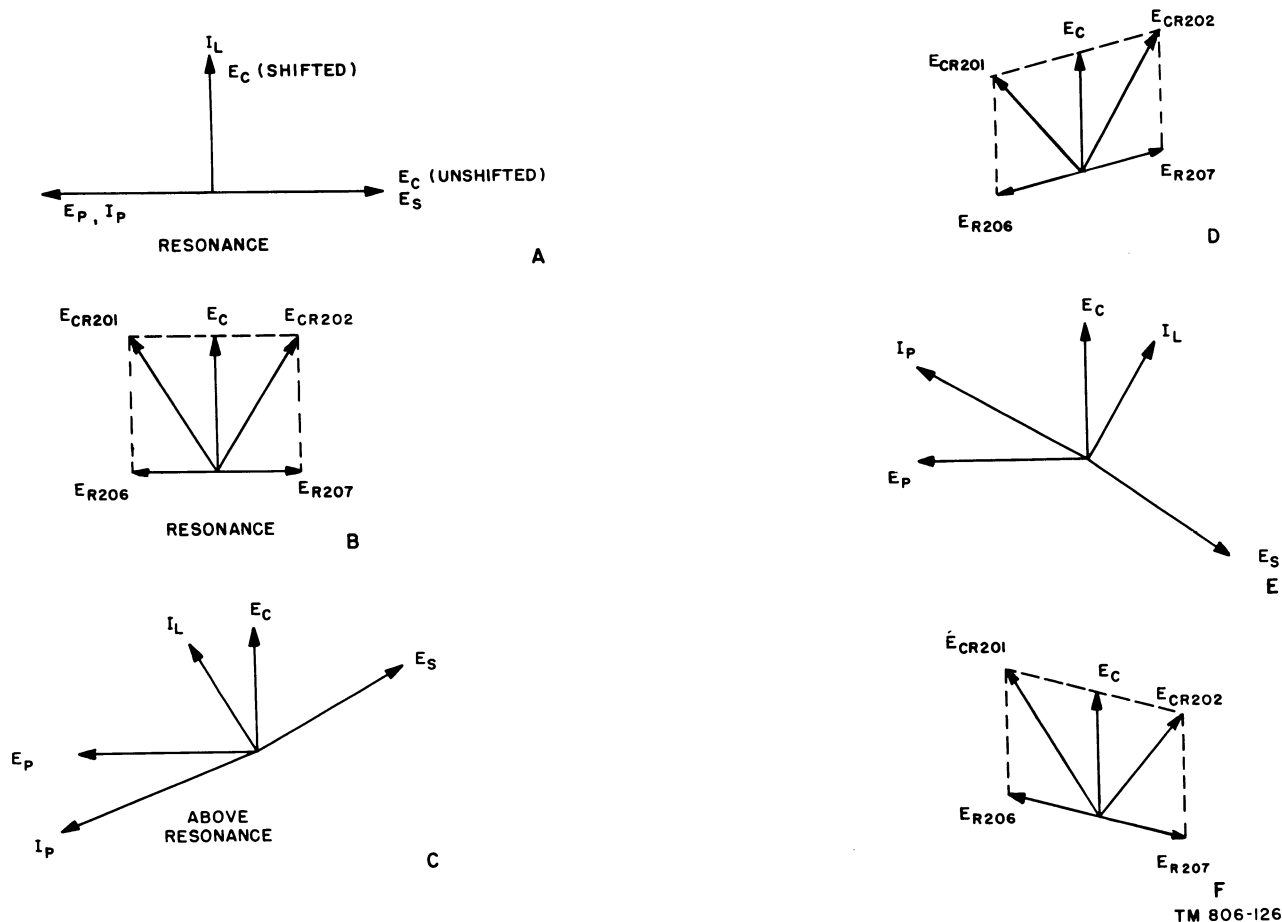

Figure 33. Power-amplifier discriminator, voltage vectors.

plified and applied to the servo mechanisms which, in turn, retune the equivalent of C1 and C2 in figure 42.

c. *Chopper G201* (fig. 34). Chopper G201 is used to convert the discriminator error voltage to a positive- or negative-going square wave for application to the pa servo-amplifier circuits.

- (1) The error signal from the discriminator is applied to pin 6 of G201. Pin 1 is connected to ground, and exciting voltage (6.3 volts, 400 cps) for the coil is obtained from the output of T901 (located in the antenna-network servo-amplifier subchassis).
- (2) The 400-cycle voltage applied to the coil of G201 causes the vibrator, or reed, contact pin 6 and pin 1 alternately. If the discriminator output voltage is negative, the square wave output of G201 will be negative. If the discriminator output is a positive voltage, the output of G201

will be positive. The output voltage 6.3 volts, 400 cps) of T901 is 25° out of phase with the 115-volt, 400-cycle voltage supplied by low-voltage dynamotor D601 (par. 89). An additional phase shift of 65° is introduced by the chopper, so that the output signal is 90° out of phase with the output voltage of D601. The output of G201 is a square wave of voltage which leads or lags the 115-volt, 400-cycle output of D601 by 90° , depending on the polarity of the discriminator error voltage. This output is applied through coupling capacitor C239 and the rf filter circuit, composed of R227 and C248, to the control grid of first servo amplifier V204A.

d. *First Servo Amplifier V204A* (fig. 34). This stage utilizes one-half of a high-gain miniature, dual triode amplifier, type 5751, to amplify the output signals from chopper G201.

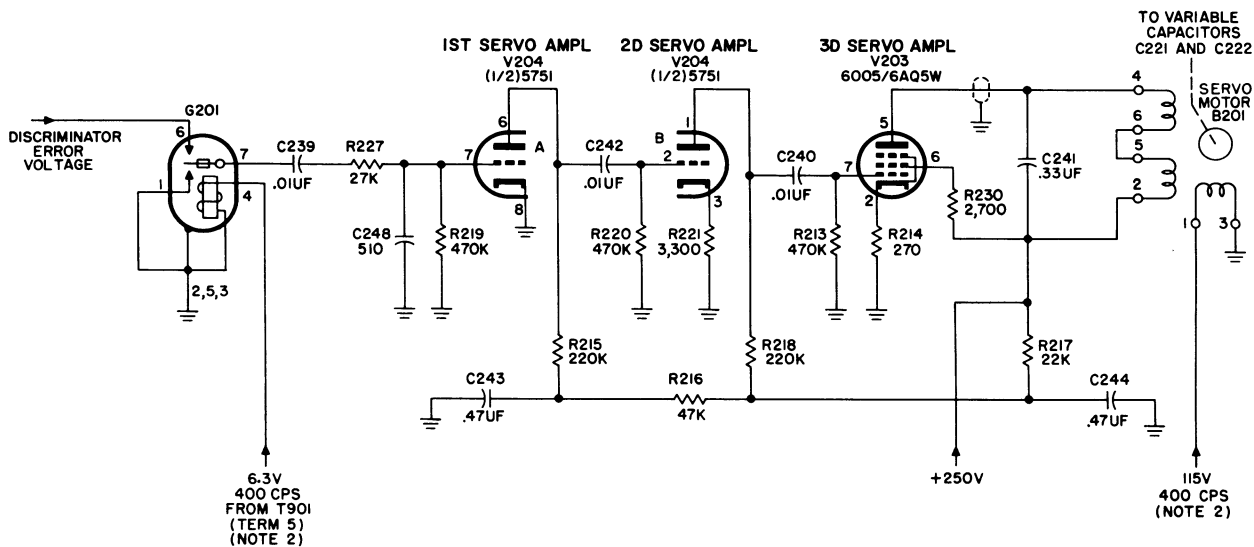

NOTES:
 1. UNLESS OTHERWISE SHOWN, RESISTORS ARE IN OHMS, CAPACITORS ARE IN UUF.
 2. SEE 115V 400 CPS VOLTAGE DISTRIBUTION.

TM 806-34

Figure 34. Power-amplifier chopper and servo amplifier stages, functional diagram.

- (1) Resistor R219 is the grid resistor, across which self-bias is generated. The cathode is at ground potential and +250 volts is applied to the plate of the tube through R217, R216, and plate load resistor R215. Capacitors C234 and C244 reduce power-supply ripple voltage and also act as decoupling capacitors.
- (2) The amplified signals are applied through coupling capacitor C242 to the grid circuit of second servo amplifier V204B.

e. *Second Servo Amplifier V204B* (fig. 34). This stage utilizes the other half of the 5751 tube (d above) to further amplify the 400-cycle signal.

- (1) Resistor R220 serves as the grid resistor for V204B, and additional tube bias is provided by cathode resistor R221. Plate voltage is applied from the +250-volt supply through R217 and R218 to the plate of the tube.
- (2) The amplified signals are applied to the grid circuit of third servo amplifier V203 through coupling capacitor C240.

f. *Third Servo Amplifier V203* (fig. 34). A miniature pentode, type 6005/6AQ5W, is used for this stage to serve as the power output tube for the servo amplifier.

- (1) Control-grid resistor R213 and cathode resistor R214 furnish operating bias for the tube, and screen-grid voltage is fed through R230 from the +250-volt supply. Plate voltage for V203 is applied through a field winding of B201 from the +250-volt supply.
- (2) The output voltage of V203 is fed to the field winding (terminals 2-4) of servo motor B201. Capacitor C241 is part of the tank circuit which acts as the plate load for V203.
- (3) The voltage applied to the one field winding (terminals 2 to 4) of B201 is 90° out of phase with the voltage applied to the other winding (terminals 3-1). The direction of motor rotation depends on whether the output of V203 leads or lags the voltage applied to terminals 3 and 1 of the motor (par. 93). The magnitude of the alternating current (ac) voltages applied to the motor winding is dependent on the magnitude of the dc error voltage applied to the servo system. The discriminator controls the rotation and speed of servo motor B201, which will rotate C221 and C222 required for tuning the power-amplifier plate circuit.

Section V. MODULATOR

65. Block Diagram

(fig. 35)

The modulator provides the proper audio power to modulate the power amplifier, and furnishes sidetone for monitoring the transmitter.

a. An af signal is fed to preamplifier tube V401A, which amplifies the signal.

b. The af output of V401A is applied to limiter V402. This stage limits, or clips, the negative and positive peaks of the audio signal before the signal is applied to the first audio amplifier.

c. A portion of the audio output of V401A is applied to sidetone amplifier V403A, which furnishes an audio signal to the headset for monitoring purposes. During cw transmission, when the audio circuits of the modulator are disabled, a 400-cycle voltage is fed to V403A through voice relay K402 to monitor the keyed signal of the transmitter.

d. The audio output of the limiter is fed to the first and second audio amplifiers, V401B and V404A, which further amplifies the signal. The output of second audio amplifier V404A is applied to modulator tube V407 and to phase inverter V404B. The phase inverter provides a 180° phase shift in the audio signal applied to modulator tube V406 so that the modulator tubes are operated in push-pull.

e. The push-pull audio output of the modulator tubes is applied to transformer T402, which delivers the af power to modulate the power amplifier.

f. The modulator subchassis contains the antenna delay tube, V403B, but this stage performs no function in the audio circuits (par. 81).

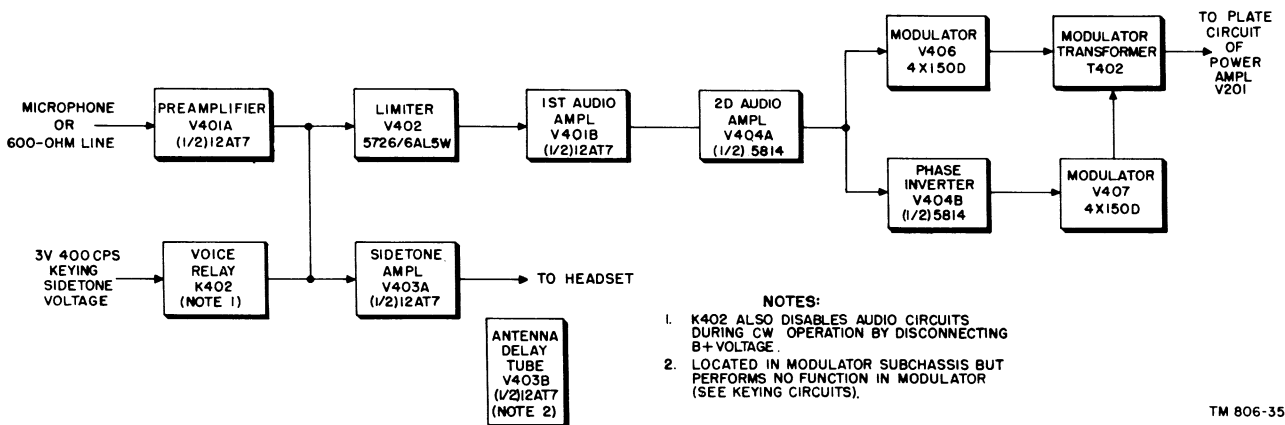

Figure 35. Modulator, block diagram.

66. Preamplifier V401A

(fig. 36)

The preamplifier stage utilizes one-half of a miniature dual-triode tube, type 12AT7, to amplify the audio signals from the microphone or 600-ohm line before they are supplied to the following stages.

a. Audio signals are fed to the preamplifier stage through AUDIO receptacle J603-C, REMOTE CONT receptacle P601-J, or RECEIVER CONT receptacle J604-C. Capacitors C664 and C605 of Z601 filter rf voltages, and the af signals are fed through coupling capacitor C406 and R403 to high pass filter Z401. Resistor R403 and the LINE LEVEL control form a voltage divider for the microphone-output voltage to reduce it to the same level as the 600-ohm line signals. R432, R401, R402, C423, and C402 constitute an RC (resistance-capacitance) filter to remove ripple voltages from the 24-volt power source for application to the microphone line.

b. An audio signal from a 600-ohm line is applied, for relay operation, through AUDIO receptacle J603-A, REMOTE CONT receptacle J601-B, or RECEIVER CONT receptacle J604-H to S602. Capacitors C629 and C613 of Z601 provide rf filtering for the input circuit. When S602 is in the RELAY position, the audio signals are applied through contacts 1 and 2 to the attenuating circuit composed of R604, R602, and R603. Potentiometers R602A and R602B, in conjunction with R603 and R604, provide for adjustment of the audio-input voltage level without changing the impedance of the input circuit.

TM 806-35

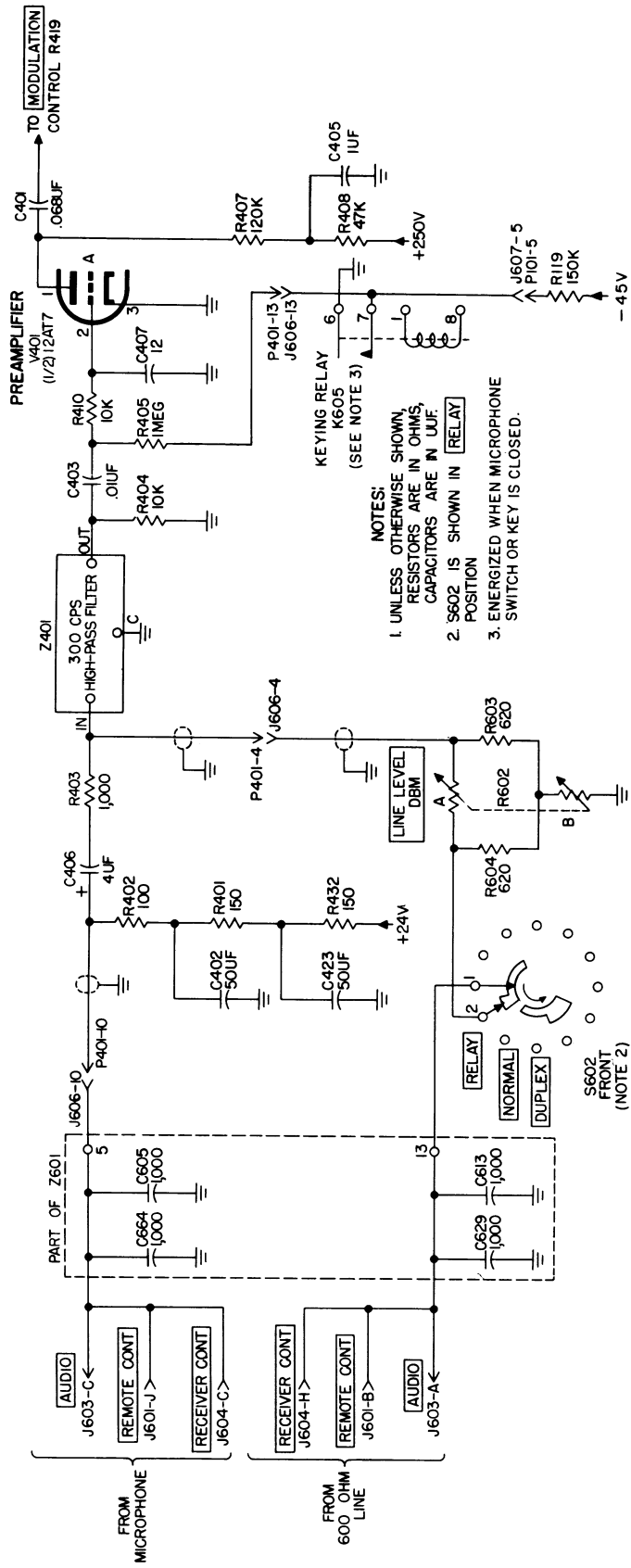

TM 806-36

Figure 36. Preamplifier stage, functional diagram.

c. Both the 600-ohm audio-input line and the microphone output are applied to the input terminal of high pass filter Z401. The filter cuts off frequencies below 300 cps; R404 is of the correct resistance to terminate this filter for proper impedance matching. The audio voltage from the high pass filter is fed through C403 to the grid of preamplifier V401A. Contact potential develops negative grid bias for the control grid of the preamplifier tube across R405. R410 and C407 serve as an rf filter. Plate voltage is fed through R408 and R407 to V401, and C405 serves as an rf bypass. When K605 is deenergized, a negative bias is applied through R119, R405, and R410 to the grid of V401A. This drives V401A to cutoff between transmissions. When the transmitter is keyed, K605 is energized and the negative bias is grounded through contacts 6 and 7. The tube will then operate in a normal manner and amplify the audio signals.

d. The amplified audio signals are fed through coupling capacitor C401 to limiter V402, and through C417 to the sidetone amplifier circuit of V403A.

67. Limiter V402

(fig. 37)

A dual-diode tube, type 5726/6AL5W, is used for the limiter stage, which removes positive and negative peaks of the audio signal.

a. Coupling capacitor C401 feeds audio voltage into MODULATION gain control R419. Audio voltage is connected from the slider of R419 to pin 1 of the limiter, V402. R411 and R416 serve as limiter input and output resistors, respectively. R413 is the common plate resistor. Resistor R414 establishes the level at which clipping starts.

- (1) A dc voltage is taken from voltage divider R414 and is applied through R413 to both plates of V402. Current flows through the voltage divider composed of R421, R409, R414, and R413, and divides through the diode sections of V402 and their load resistors, R411 and R416. The dc voltage drop under static conditions maintains all parts of the circuit as a positive potential above ground. The voltage drop between the plate and cathode of each diode section of V402 is very small compared with the drop across resistor R413.

- (2) Limiting does not occur until the peak audio input voltage reaches a value greater than the static voltage at the plates of the diodes. Assume that R414 has been set to a point that will give 1 volt at the plates of V402.

- (3) As long as the audio input through C401 is of a magnitude that will not drive the first cathode (pin 1 of V402) more than 1 volt above ground, the plate will at all times be more positive than this cathode, and the tube will conduct. The radio signal developed across R411 will then also appear across R413 and a portion of R414.

- (4) Should this input voltage be increased to a value exceeding 1-volt peak, the cathode will become positive with respect to the plate and conduction will stop. The audio voltage developed across R413 will display the original full negative swing, but will be clipped at the arbitrary 1-volt positive level.

- (5) The audio voltage developed across R413 is superimposed on a 1-volt dc potential; therefore, only on negative portions in excess of 1-volt peak value will the plate of V402 reach a negative potential with respect to ground. The second cathode (pin 5 of V402), which is at ground potential, will then permit conduction for all signal levels except those which drive the plate of V402 negative. When this occurs, clipping of the negative portion will take place.

- (6) The end result of this process is that clipping of the positive half of each cycle takes place in the first diode of V402, and clipping of the negative half cycle takes place in the second diode. In either direction, the voltage may not exceed the clipping level set by adjustment of R414. The clipped voltage will then be developed across R416.

b. The output of the limiter is fed through coupling capacitor C421, which removes the dc component from the audio voltage applied to low-pass filter Z402. The audio output voltage from the filter is within a narrow pass band, with the low frequencies attenuated by Z401 (fig. 36) and the high frequencies attenuated by Z402.

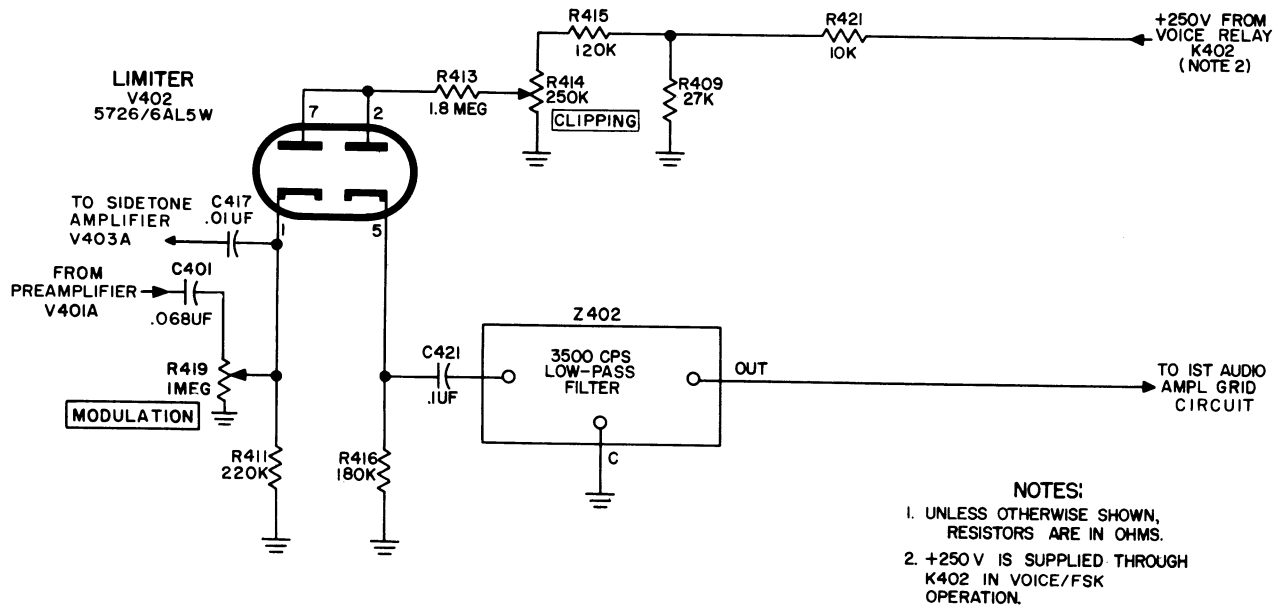

TM 806-37

Figure 37. Limiter stage, functional diagram.

68. First Audio Amplifier V401B

(fig. 38)

One-half of a type 12AT7 dual-triode, V401B, is used to amplify the output signals from the limiter stage.

a. The output signals from the low-pass filter are applied to the junction of resistors R418 and R452. Resistor R452 is the grid resistor. Cathode bias for the first audio amplifier is de-

veloped across R420. During voice/frequency-shift keyed operation, voice relay K402 is energized, and +250 volts is fed to the voltage divider composed of R409 and R421. Plate voltage is taken from the junction of R409 and R421 and is applied to the plate of V401B through R422. Capacitor C409 prevents audio voltages from feeding back into the power supply.

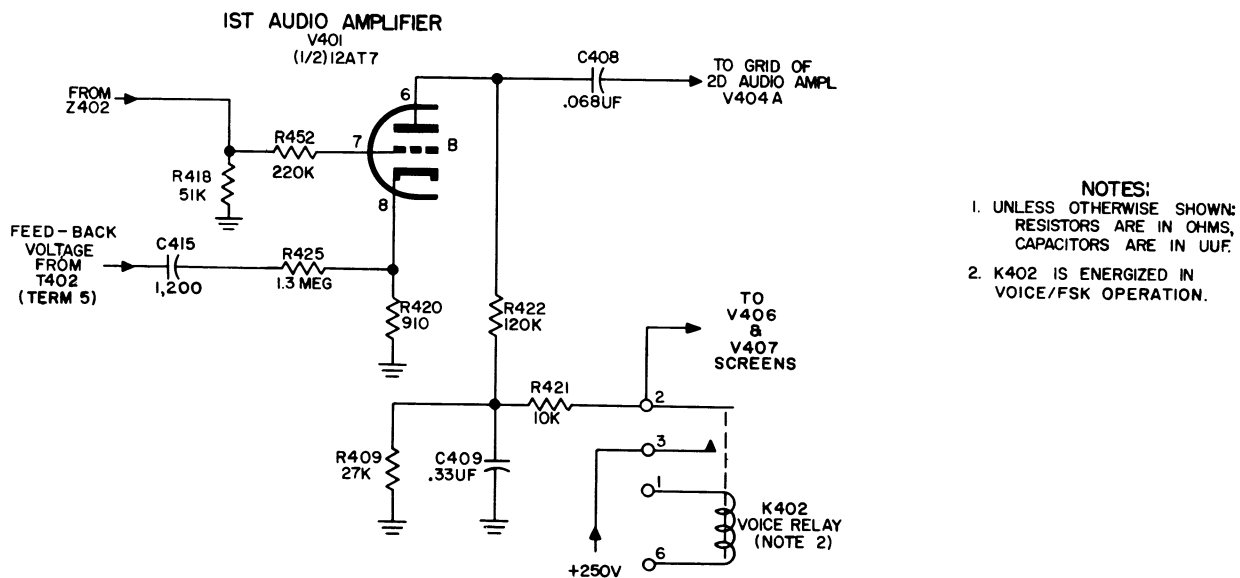

TM 806-38

Figure 38. First audio amplifier, functional diagram.

b. The amplified af signals are fed to the grid of the second audio amplifier through coupling capacitor C408.

69. Second Audio Amplifier V404A

(fig. 39)

One-half of a type 5814 dual-triode, V404A, is used for this stage which further amplifies the audio signals.

a. The output signals from the first audio amplifier are applied to the control grid of V404A. Grid resistor R423 and cathode resistor R424 establish the operating level of the tube, and plate voltage is supplied through R428. Cathode resistor R424 is bypassed to ground by filter capacitor C427.

b. The amplified output signals at the plate of V404A are fed simultaneously to the control grid of modulator tube V407 through coupling capacitor C411, and to the control grid of the phase inverter through coupling capacitor C410, and the voltage divider composed of resistors R427 and R426.

70. Phase Inverter V404B

(fig. 39)

The phase inverter, V404B, is used to produce an audio signal of the same amplitude as that of V404A, but 180° out of phase, to provide push-pull audio voltages to the modulator tubes. The phase inversion is accomplished by the additional stage of amplification.

a. The output voltage from V404A is coupled to the grid of V404B at the proper level through C410, R426, and R427. Plate voltage for V404B

is supplied through plate resistor R429, and cathode bias is developed across R424 (common to V404A and V404B).

b. The phase inverter output signals are connected to the control grid of modulator tube V406 through coupling capacitor C412.

71. Modulator Tubes V406 and V407

(fig. 40)

The output signals of V404A and V404B are applied to V407 and V406, respectively. Two tetrodes, type 4X150A, are operated in push-pull for this stage.

a. Audio voltage from the audio amplifier and phase inverter is coupled to the modulator grid circuits through C411 and C412. Negative 45 volts is applied to the modulator grids through R430 and R431 to establish the proper operating point for class AB modulator operation. The primary winding of output transformer T402 is center-tapped to +1,000 volts, which is supplied also to the secondary winding. C659 serves as a filter for this voltage. The +1,000 volts is applied through T402 to the plates of V406 and 407 in parallel, and the cathodes of both tubes are at ground potential. Screen voltage for both tubes is applied directly from the +250-volt power source through contacts 2 and 3 of relay K402 when K402 is energized in the VOICE/FSK position.

b. To secure low distortion, a feedback circuit, consisting of R425 and C415, couples a small audio voltage back to the cathode of the first audio amplifier. This reduces the distortion so that the modulator faithfully reproduces the audio wave

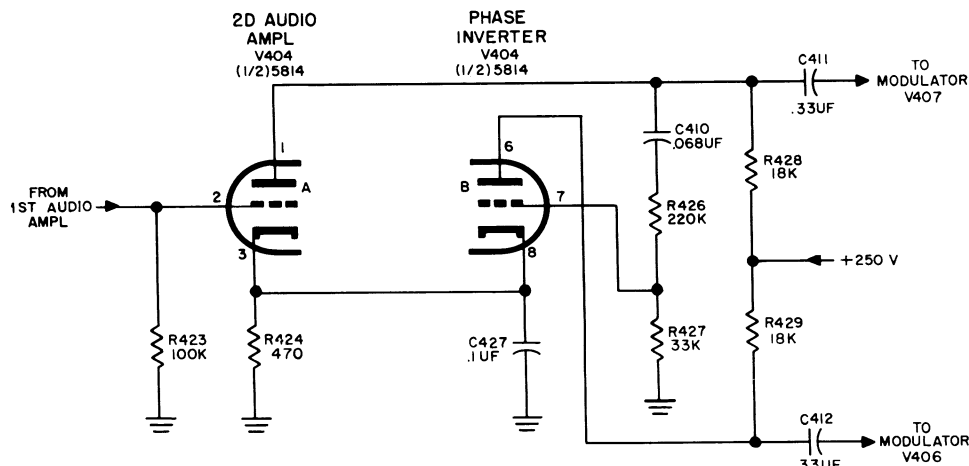

TM 806-39

Figure 39. Second audio amplifier and phase inverter, functional diagram.

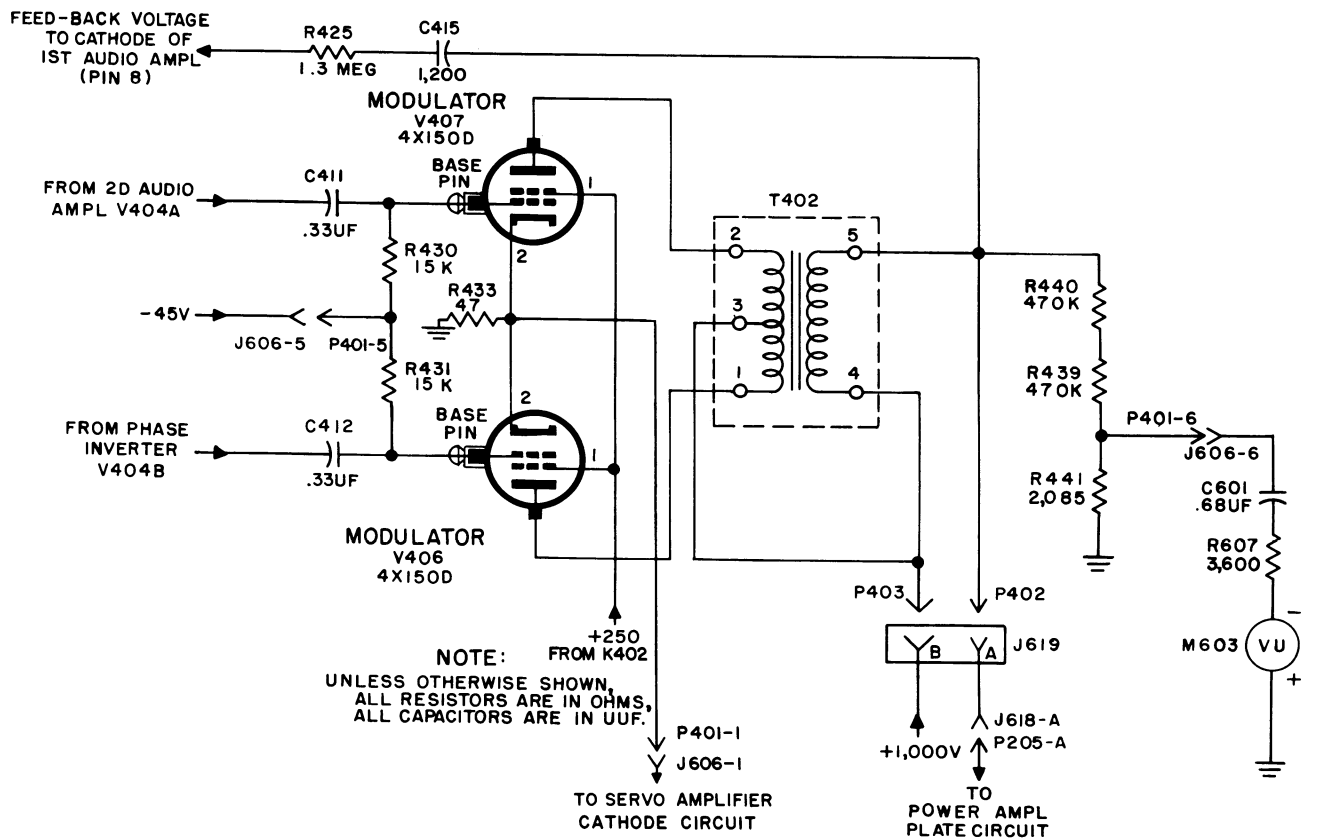

TM 806-40

Figure 40. Modulator stage, functional diagram.

applied to the first audio amplifier. The output terminal of modulation transformer T402 is connected to a resistive voltage divider, R439, R440, and R441, to supply voltage to audio level meter M603. Capacitor C601 couples this voltage to M603 through current-limiting resistor R607. The meter indicates audio level in volume units. To decrease the sensitivity of the phasing amplifier in the antenna servo amplifier, the modulator cathode voltage developed across R433 is connected to the cathode return of the second phasing amplifier, V201.

c. The push-pull audio voltage output of the modulator tubes is applied to the primary winding of T402, and the secondary winding provides af power to modulate power amplifier V201.

72. Sidetone Amplifier V403A

(fig. 41)

The sidetone amplifier amplifies the audio signals for voice operation and the keyed tone for cw operation.

a. Part of the audio output of the preamplifier is fed to the sidetone adjustment, R436, through coupling capacitor C417, when the transmitter is set up for voice or frequency-shift keyed or voice operation. When the transmitter is set up for cw or frequency-shift keyed operation, voice relay K402 is not energized, and a 400-cycle voltage is fed from the antenna and network servo amplifier through R914, K402, and C420 to R436. The signal is fed to the control grid of V403A at the proper level, as determined by R436.

b. Bias voltage for the grid of the tube is derived from the -45-volt source, which is fed through resistors R119 and R406 to the grid circuit. This negative bias keeps the tube at the cutoff point. When keying relay K605 is energized, the junction of R406 and R119 is grounded; this removes the negative bias and allows V403A to conduct. Additional bias voltage is developed across R437, connected between cathode and ground. Plate voltage for the tube is supplied from +250 volts through the primary winding of T401.

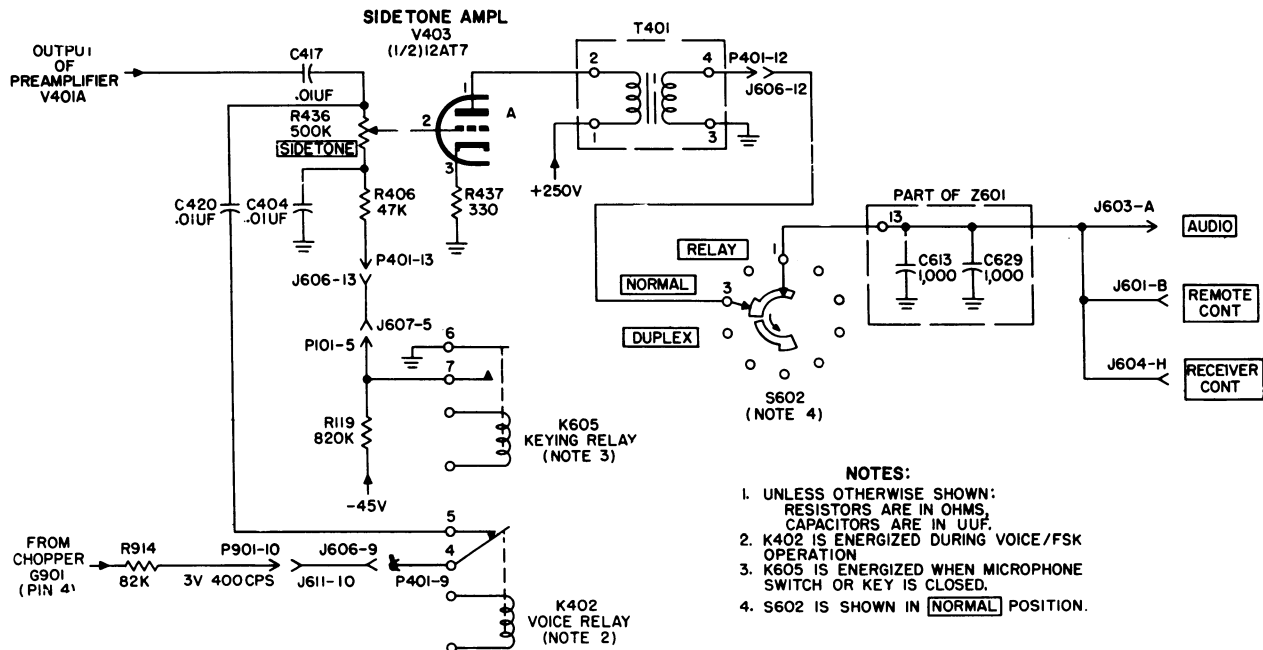

Figure 41. Sidetone amplifier stage, functional diagram.

c. When V403A conducts, the audio signal, or 400-cycle voltage, is amplified and applied from the plate to output transformer T401. When S602 is in **NORMAL** position, the sidetone voltage

is fed through contacts 3 and 1 of the switch to the rf filter circuit composed of C613 and C629, and to the output receptacles to the 600-ohm line for monitoring purposes.

Section VI. ANTENNA TUNING SYSTEM

73. General

a. The antenna tuning system is used to provide proper loading for the pa, to provide an antenna impedance of 73 ohms, and to match the antenna impedance to the pa plate load, so that maximum rf power is radiated.

b. As shown in figure 42, the antenna tuning system can be divided into the following three sections:

- (1) The pa tuning circuits that provide the plate load for the pa tube.
- (2) The antenna, which will present an impedance to the antenna matching network.
- (3) The antenna matching network which will match the pa plate load to the 73 ohms impedance of the antenna.

c. The pa tuning circuit consists of an output capacitor (C1), an inductor (L204), and an output capacitor (C2). These components are shown

in equivalent form in figure 42; for accurate detail, see figure 31. If the pa plate circuit is not properly tuned, capacitive or inductive reactance will cause the phase shift between the pa grid voltage and the pa plate voltage to vary from 180°. This phase shift is interpreted by the pa discriminator as an error voltage that is used to control the amount of capacitance of C1 and C2. Refer to paragraph 64b.

d. When the output circuits are properly tuned for a given frequency, they are in a resonant condition and the current and voltage are *in phase*. A change in frequency will result in a nonresonant condition in the output circuits. Any nonresonant condition in the output circuits of the transmitter will result in an *out-of-phase* condition of current and voltage in the antenna matching network. The output circuits then become either inductive or capacitive, and the current in the antenna matching network leads or lags the voltage. Because of this out-of-phase condition, the phasing

discriminator functions to restore the *in-phase* condition of the antenna and output circuits by increasing or decreasing the capacitance of the antenna tuning capacitor. Refer to paragraph 76.

e. With a change in frequency, the output impedance of the antenna matching network also changes. A change in impedance causes a change in the relative amplitudes of voltage and current in the antenna matching network. These amplitudes normally have a ratio of 73 to 1. Any deviation from this ratio will cause the loading discriminator to produce an error voltage (par. 76). The error voltage causes the variable inductor to be changed in value until the proper ratio and, therefore, the proper output impedance is obtained (par. 76). At the same time, the antenna tuning capacitor is adjusted by the phasing discriminator until the antenna matching network is in a resonant condition with an output impedance of 73 ohms.

f. The output capacitors are connected in parallel with the antenna at the low end of the transmitter frequency range, in series with it at the middle frequencies, and in series and in parallel with it at the high end of the range. They decrease the tuning range that the matching network must cover in the following manner:

(1) From 1.5 to 3 mc, the antenna has a high capacitive reactance. The antenna tuning capacitor and the variable inductor do

not vary over a range wide enough to compensate for this high capacitive reactance. By adding shunt capacitance, the high capacitive reactance is decreased enough, so that the range of the antenna tuning capacitor and the range of the variable inductor are sufficient to tune the circuit.

(2) From 3 to 9 mc, the antenna has a lower capacitive reactance. The tuning range of the antenna tuning capacitor and the variable inductor are sufficient to tune the circuit; therefore, no output capacitors are necessary.

(3) From 9 to 12 mc, the antenna becomes inductive. The output capacitors are placed in series with the antenna. Their reactance is sufficient to cancel the inductive reactance of the antenna and make the antenna slightly capacitive. When the antenna is capacitive, the antenna matching network can tune it.

(4) From 12 to 20 mc, the antenna is inductive and its impedance is much higher than 73 ohms. The output capacitors are added in series and in parallel to provide an antenna circuit which is slightly capacitive with an impedance of 73 ohms. Then the antenna matching will have sufficient tuning range to tune the circuit.

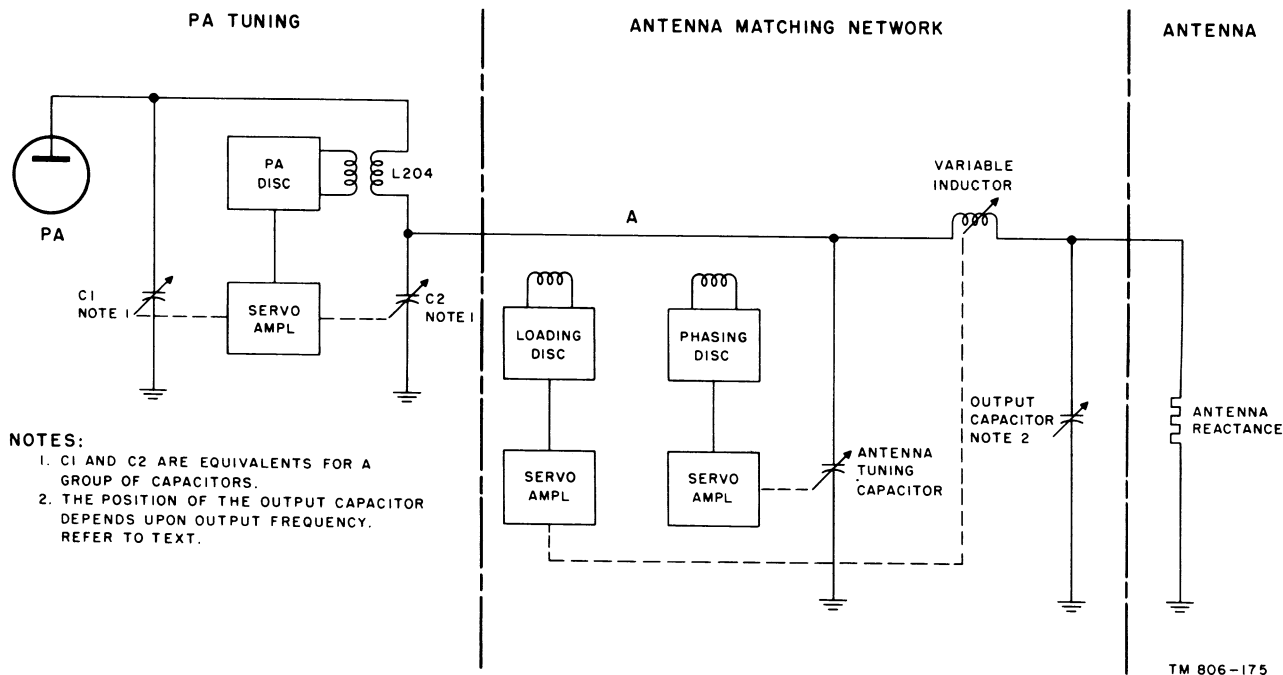

Figure 42. Antenna tuning system, simplified schematic.

74. Block Diagram

(fig. 43)

a. The antenna tuning capacitor, the variable inductor, and the antenna output capacitor comprise a tuned circuit. The antenna tuning capacitor and the variable inductor are controlled by the homing circuits and the discriminator. The output capacitor, controlled by motor switch relay K613, is energized when the BAND SELECTOR control is moved to a new position.

b. The complete tuning cycle for the antenna output network can be divided into two parts as follows:

- (1) The homing cycle places the antenna capacitors in the position for minimum capacitance, and, at the same time, positions the variable inductor to an approximate setting, corresponding to the operating band selected. Homing is initiated by rotation of the BAND SELECTOR control, which also causes motor switch relay K613 to become energized, causing a proper value of output capacitance to be selected by S612. Plate voltage to the power-amplifier tube is cut off during the homing cycle, and no signal is transmitted. When the homing cycle is completed, plate voltage is applied to the power amplifier again, and the second portion of the antenna tuning cycle starts.
- (2) The application of high voltage to the plate of the power-amplifier tube initiates the second portion of the tuning cycle. This accurately positions the antenna tuning capacitors and the variable inductor so that the power amplifier operates into a purely resistive load of 73 ohms. The discriminator output signals control the final positioning of the variables in the tuned circuit.

c. When the BAND SELECTOR control is moved to a new position, the following actions occur (fig. 43).

- (1) Relay K613 becomes energized, which, in turn, energizes motor B603. This motor controls S612, which selects the proper combination of capacitors for the selected operating band.
- (2) After the output capacitor selection has been completed, a positive voltage is applied by the homing circuits to the phasing

portion of the servo amplifier. This positive voltage is converted to a square wave by chopper G901 and is then amplified by tubes V901 and V902. The output of V902 is applied to motor B1001, which rotates in a direction to reduce capacitance. Variable capacitors C1003 and C1002 are controlled by the motor and S1002 is controlled by a lost motion drive. C1003 and C1002 rotate in the homing direction and continue to rotate until S1002 is driven to a position of minimum capacitance and operates S1003.

- (3) At the same time that the antenna tuning capacitor is being positioned, a voltage is applied through the homing circuits to dc motor B1102. The motor then rotates to adjust variable inductor L1101, so that an approximate value of inductance is obtained for the band selected. Motor B1101 is disabled during the homing cycle.
- (4) When the variable capacitor and the variable inductor reach their *home* positions, the homing circuits are disabled, and high voltage is applied to the plate of the power-amplifier tube. Rf energy is applied to the phasing and loading discriminator, which applies error voltages to the phasing and loading sections respectively of the antenna network servo amplifier.
- (5) Chopper G901 converts the dc error voltages from the discriminator to the square wave voltages before they are applied to the amplifier sections. The phasing amplifier supplies voltage to motor B1001 in the antenna tuning capacitor. The loading amplifier supplies power to motor B1101 in the variable inductor.
- (6) The antenna tuning capacitor motor rotates in a direction depending on the polarity of the error voltage from the discriminator. During homing, the output of the phasing discriminator is negative and the capacitance is reduced to a minimum. Then, the motor rotates to add capacitance to the transmitter output circuit. Variable capacitors C1003 and C1002 move through their range toward maximum capacitance, and the lost motion drive rotates to engage switch

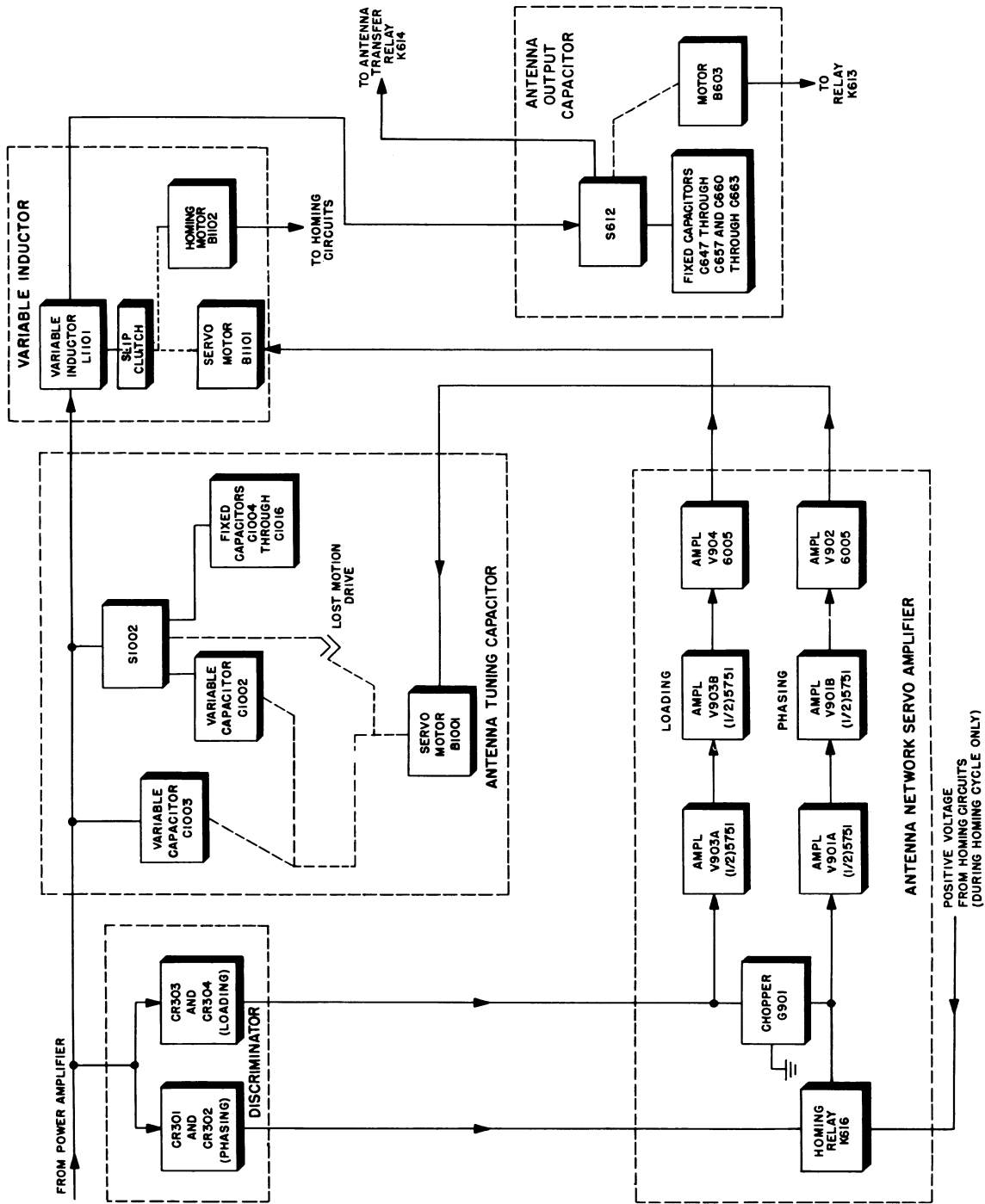

TW806-42

Figure 43. Antenna tuning system, block diagram.

S1002. When capacitors C1003 and C1002 have completed 360° of rotation, S1002 finally becomes engaged and begins to move to add capacitance to the output circuit until slightly more than required capacitance is obtained. At this point, the polarity of the phasing discriminator error voltage reverses, causing motor B1001 to reverse. This leaves S1002 stationary, because of the lost motion drive, and C1003 and C1002 move in a direction to reduce capacitance, until the proper amount of capacitance is obtained. At this point, the phasing discriminator error voltage is zero, and the motor stops.

- (7) During the sequence of operation described in (6) above, the loading section of the antenna network servo amplifier has a large bias imposed upon it, which reduces the sensitivity of the amplifier. As the phasing discriminator error voltage approaches zero, the bias is reduced, and full amplification of the loading discriminator error voltage occurs. The amplified signal is applied to motor B1101 and homing motor B1102 is disabled. B1101 rotates in a direction to add or remove inductance from L1101 (depending on polarity or error signal) until the inductor is properly positioned, and the error voltage is zero.

75. Homing Circuits

(figs. 44 and 45)

Figure 44. Homing cycle flow chart.

Figure 45. Homing circuits, functional diagram.

(See Attached Envelope)

The homing circuits are shown in figure 45, with the SERVICE SELECTOR switch set to the VOICE/FSK position and with the antenna tuning capacitors and variable inductor L1101 properly homed for operation in the 1.5- to 1.7-mc band. The positions of the BAND SELECTOR and homing switches for this band are indicated by the solid lines. For the following discussion, it will be assumed that the BAND SELECTOR switch is moved to a new position, for operation in the 4- to 6-mc band. Final switch positions for this band are indicated by dotted lines.

a. Initiation of Homing Cycle. When the BAND SELECTOR control is moved to the 4- to 6-mc band, switch S101E is moved to the position indicated by the dotted lines, and the normally open contacts of cam-operated switch S203 close momentarily. This results in the following:

- (1) Terminal 10 of homing relay K616 is now connected to ground through S203, contacts 4 and 7 of S1101B (front), and contacts 10 and 8 of S101E (front). S1003 presents a path to ground, through its contacts 2 and 3, when S1002 is not in its position of minimum capacitance. When terminal 10 of K616 is grounded, the relay coil is energized, and although the momentary connection to ground through S203 is broken, a new ground path is established through holding contacts 5 and 6 of K616, and the switches mentioned above. The homing relay remains energized until the ground path to contact 5 is broken. This occurs only when the antenna tuning capacitors are positioned for minimum capacitance and the variable inductor is in one of four preset positions, depending on the position of S101E (front).
- (2) If the Autotune cycle has been completed, thus deenergizing relay K609, and the output capacitor circuit has completed its cycle (after which relay K613 is deenergized), 24 volts are applied through contacts 2 and 3 of K609 and contacts 4 and 3 of K613, to contact 3 of homing relay K616. With K616 energized, this voltage is fed through contact 4 to motor reversing relay K617 (contacts 2, 7, and 10). K617, when deenergized, applies 24 volts to homing motor B1102 through contacts 2 and 3. The homing motor is not energized, however, because in the VOICE/FSK position, the SERVICE SELECTOR switch does not furnish a ground for the motor until TEST KEY S603 is closed.
- (3) Contact 7 of relay K616 is connected to contact 3 through voltage-dropping resistor R620. A positive voltage is applied through contact 8 (with K616 energized) to the phasing servo-amplifier input circuit. (Contacts 8 and 9 normally feed the output of the phasing dis-

criminator to the phasing servo amplifier.) The output of the phasing servo amplifier is applied to antenna tuning capacitor motor B1001. This servo motor does not operate at this time, since low-voltage dynamotor relay K602 is not energized with S606 in the VOICE position, and operating voltages for the motor are not supplied by the low-voltage dynamotor (fig. 61).

Note. The antenna tuning capacitors are shown in figure 45 in their home position. Normally, before homing, S1002 is at some position away from S1003, and contacts 2 and 3 of S1003 are closed.

b. Completion of Homing Cycle. TEST KEY S603 must be held closed by the operator to complete the homing cycle when the SERVICE SELECTOR switch is set to the VOICE/FSK position.

Note. When S606 is set to the CW position, the TEST KEY need not be pressed to complete the homing cycle.

- (1) As shown in figure 45, if the TEST KEY is closed, contacts 1, 2, 10, and 11 of S606A, front) are connected to ground through contact 9 of S606A (front) and contacts 10 and 9 of S603. When the SERVICE SELECTOR switch is set to CW position, contacts 1 and 11 of S606 are grounded through contact 12. This completes the circuit of homing motor B1102, through contacts 9 and 8 of reversing relay K617, and the motor rotates to position variable inductor L1101. The lv relay, K602, is also energized, and lv dynamotor D601 supplies operating voltages to antenna tuning capacitor motor B1001. Since a positive voltage is applied to the phasing servo amplifier (*a*(3) above), this motor rotates in a direction to decrease the capacitance of the antenna tuning capacitors.
- (2) Variable inductor L1101 and switch S1101 are ganged to the shaft of homing motor B1102 through a slip clutch. Assuming that K617 is deenergized (as shown), B1102 rotates S1101 in a counterclockwise direction (toward minimum inductance) until S1101B (front) opens the ground path for contact 5 of K616 (*a*(1) above), through contact 7 of

S1101B (front) and contacts 10 and 8 of S101E (front).

- (a) If the antenna tuning capacitors are positioned for minimum capacitance (homed), by this time, thus opening the ground path through contacts 2 and 3 of S1003, the ground connection through the holding contacts (5 and 6) to the coil of K616 is lost. The relay then becomes deenergized, and voltage to motors B1001 and B1102 is removed. Capacitor C644 prevents arcing between contacts 3 and 4 of K616 when power is applied or removed from homing motor B1102.
- (b) If the antenna tuning capacitors are not homed by this time, the ground connection to the coil of homing relay K616 is maintained through S1001 and S1003. Motor B1102 rotates S1101 past its *home* position, re-establishing the ground path to K616 through S1101B (front) and S101E. Homing motor B1102 continues to rotate S1101 in a counterclockwise direction until contacts 12 and 2 of S1101A (front) close, to provide a momentary ground path through S1101A (rear) to the coil (terminal 1) of reversing relay K617. Terminal 10 of K617 is connected to 24 volts through contacts 3 and 4 of K616, and the coil of the reversing relay is energized. This connects contact 3 of K617 to ground instead of to 24 volts, and contact 8 connects to 24 volts instead of to ground, thus reversing the polarity of the voltage applied to B1102. The motor now reverses, and S1101 rotates in a clockwise direction (toward maximum inductance). The ground path for the coil of K617 through S1101A (front) is now broken, but the holding contacts (6 and 5) of K617 maintain a path to ground through S1101A (rear). This connection is maintained until S1101 is rotated to its clockwise limit (maximum inductance), at which point the connection between contacts 2 and 4 of S1101A (rear) is broken, and the ground path to K617 is opened. K617 becomes deenergized, and the polarity

of the voltage to motor B1102 is again reversed. This action continues until the antenna tuning capacitors are *homed*. Refer to (2) and (2)(a) above.

- (3) During homing, variable capacitors C1002 and C1003 rotate in the *home* direction, and the lost motion drive engages S1002. Variable capacitors C1002 and C1003 continue to rotate and S1002 disconnects fixed capacitors one at a time in detent steps until the last detent position is reached and the motor stalls. At this point, contacts 2 and 3 of S1003 open, thus removing the ground path to relay K616 through the antenna tuning-capacitor switches. Motor B1001, which is designed for *stalled operation*, remains stalled until variable inductor L1101 *homes* and relay K616 becomes deenergized, removing power from both motors.

c. Auto Homing. During discriminator tuning, a fault may occur which would position both the antenna tuning capacitors and the variable inductor to their minimum positions. The auto homing switch, S1101B (rear), serves to initiate a new homing cycle by making a ground connection to K616 (terminal 10) through contacts 4 and 5 of S1003 and contacts 5 and 1 of S1101B (rear).

d. Additional Information.

- (1) Motors B1101 and B1102 are coupled through a slip clutch to the variable inductor at all times; but because of the action of the motor disabling relay, only a very little frictional drag is introduced by the servo motor (B1101) during homing. This relay, K604, removes 115-volt, 400 cps current from B1101 when the homing motor is energized. The slip clutch is adjusted to a preset torque so that the dc motor will continue to rotate when the end stop has been reached.
- (2) During homing, the hv dynamotor is disabled by removing 24 volts from terminal 1 of the coil of hv relay K603; this deenergizes the relay. Contact 2 of the homing relay normally connects one side of the coil of K603 to 24 volts. When the homing relay is energized, contact 2 is disconnected from 24 volts.

76. Phasing and Loading Discriminator

The phasing and loading discriminator is composed of two separate circuits; the phasing discriminator, and the loading discriminator. These circuits provide a means of readjusting the capacitance and inductance of the transmitter output circuit (when a new operating frequency is selected), so that the transmitter operates into a properly matched (resistive) load of 73 ohms.

a. Phasing Discriminator (figs. 42, 46, and 47). The phasing discriminator produces an error signal, the amplitude of which is proportional to the phase angle existing between the rf output voltage and current. This error signal is used to adjust the antenna tuning capacitor, to increase or decrease capacitance as required. The operation of the phasing discriminator circuit is as follows:

- (1) A toroidal coil, L304B, couples a portion of the rf output E_p to the discriminator. R309 acts as a load resistor for the coil. A reference voltage E_c , is coupled to the center tap of L304B through a voltage divider composed of C306 and C302. No phase shift takes place across the voltage divider. The reference voltage, E_c , appears across R302 in parallel with R301.
- (2) In a properly terminated circuit, the output of the pa is applied to a resistive circuit, consisting of the antenna tuning capacitor, the antenna output capacitor, the variable inductor, and the antenna (fig. 42). Therefore, at resonance, the line voltage E_p , and the line rf current, I_p , at A, figure 42, are in phase with each other. I_p induces a secondary voltage, E_s , which lags I_p by 90° (A, fig. 47).
- (3) Using the midpoint of L304B as a reference, one-half of the total voltage, $1/2E_s$, across L304B, is applied to crystal diode CR301 in series with the reference voltage, E_c , across R301. The other half is applied to crystal diode CR302 in series with the voltage, E_c , across R302. The addition of the voltages applied across CR301 and CR302 is shown in B, figure 47. Rectified voltage E_{R301} developed across R301 will be proportional to E_{CR301} . Rectified voltage E_{R302} developed across R302 will be proportional to E_{CR302} . The direction of current flow and the polarity of the developed voltages

across R301 and R302 is indicated in figure 46. At resonance, the voltages applied to CR301 and CR302 are equal. Therefore, the rectified voltages across R301 and R302 are equal and opposite in polarity. The net result is that no error voltage is developed by the discriminator.

- (4) When a mismatch occurs by switching to a lower frequency, the rf voltage and current are no longer in phase. The antenna circuit is capacitive at the lower frequency, and the rf current I_p will lead the rf voltage E_p (C, fig. 47). The shift in the phase of I_p causes the voltage E_s developed in L304B also to be advanced (C, fig. 47). The addition of the voltages applied across CR301 and CR302 is shown in figure 47. E_{CR302} will be larger than E_{CR301} ; therefore the rectified voltage developed across R302 is larger than the voltage developed across R301. The net result is a positive voltage developed by the discriminator.
- (5) The voltage relationships developed by an inductive circuit in which the rf current, I_p , lags the voltage E_p are shown in E and F, figure 47. The addition of the voltages indicates the development of a negative voltage by the discriminator.
- (6) The dc output voltage of the phasing discriminator is fed through the rf filter circuit composed of C301 and R307, to an attenuating circuit which varies the amplitude of the voltage with respect to frequency. This is necessary because the output of the discriminator varies approximately 16 db over the entire frequency range of the transmitter. Switch S614B (front) is controlled by output capacitor motor B603, so that when output capacitance selection is made for a particular operating frequency, the attenuating circuit is also adjusted. In figure 46, the switch is shown positioned for transmitter band 1 (1.5 to 1.7 mc). For bands 1, 2, and 3 (1.5 to 2.4 mc), the discriminator output is fed, without attenuation, through contacts 1 and 8 of S614B (front) and the normally closed contacts of homing relay K616, to the antenna network servo amplifier. For band 4 (2.4 to 3 mc), the voltage is fed

through contacts 1 and 4 of the switch, and no attenuation takes place. For bands 5, 6, 7, 8, and 9 (3 to 16 mc), the discriminator voltage is fed through voltage dropping resistor R606, and through contacts 5 and 4 of the switch, to the contacts of the homing relay. For band 10 (16 to 20 mc), the voltage is fed through R606 and contacts 5 and 8 of the switch to relay K616. Capacitor C621 is connected across R606 to remove ripple from the dc voltage.

- (7) The error voltage is used then to drive the servo which varies the antenna tuning capacitor until I_p and E_p are in phase (par. 77).

b. Loading Discriminator (figs. 42 and 48). The relationship between voltage and current amplitudes of the transmitter output signal can be expressed by the ratio of $Z = E/I$. From this formula, if the load impedance Z increases, the load current I decreases, and therefore the rf plate output voltage E must increase. Physically, an increase in the load impedance Z causes a decrease in I . This results in a smaller IR drop across the internal plate resistance of the power amplifier, and thus increases the amplitude of the rf output. Similarly, if the load impedance decreases, the current will increase, the IR internal plate resistance drop will increase, and the rf output voltage will decrease. The loading discriminator interprets these relative changes in rf voltage and current as dc voltages, the polarities of which are determined by the direction of the change.

- (1) L304A is a coil wound on the same iron toroid form used for the phasing discriminator. The coil is inductively coupled to the rf output circuit. The voltage induced across L304A is proportional in amplitude to the rf line current. This induced voltage is applied to crystal rectifier CR 304 through current limiting resistors R308 and R310. The rectifier causes a dc potential to appear across R304, which is proportional to the voltage across L304A (electron-current flow is indicated by the arrows in figure 48). C307 is a compensating capacitor that permits the voltage developed across R304 to remain constant regardless of frequency. At the low frequencies, C307 acts as open circuit and has little effect.

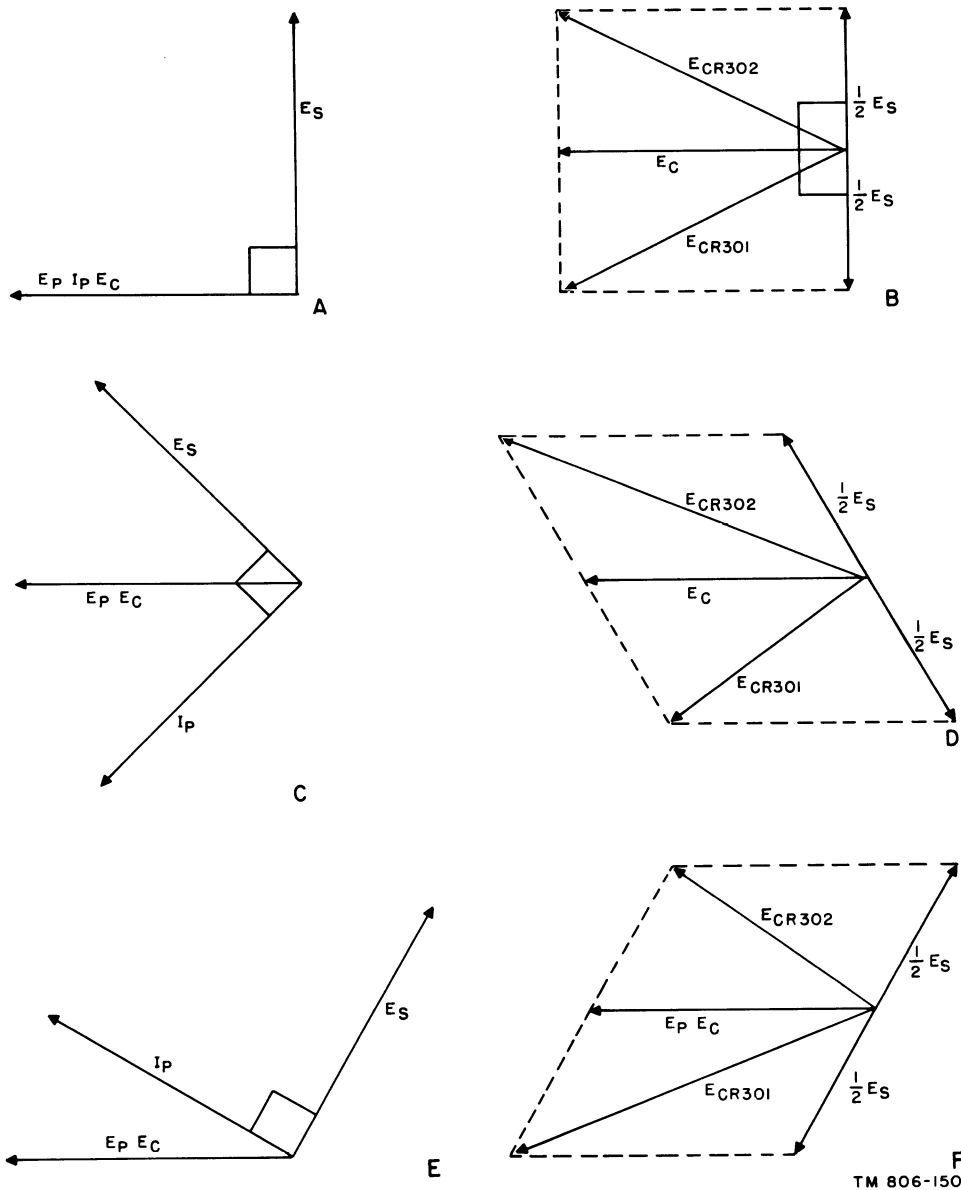

Figure 47. Phasing discriminator, voltage relationships.

stant. At the lower frequencies C308 has little effect. At the higher frequencies, C308 reduces the voltage applied across R303 and thereby reduces the voltage developed across R305.

- (2) When the magnitude of the load impedance is changed from 73 ohms, a dc potential will be present at the discriminator output. If the impedance is raised, the line voltage will increase and the line current will decrease. This results in an increase in the voltage across R305 and a decrease in the voltage across R304.

Since these voltages are added back to the net output voltage is negative. If the load impedance is reduced below 73 ohms, the line current will increase and the line voltage will decrease; this results in a larger dc potential across R304 than that across R305, and the net output voltage is positive. In this manner, the dc output voltage of the loading discriminator indicates whether the magnitude of the rf impedance is above or below 73 ohms. This error voltage is then used to

adjust the variable inductor until the rf impedance is 73 ohms.

- (3) The dc output voltage of the loading discriminator is fed through an rf filter circuit composed of C303, C304, and R306 to an attenuating circuit. This circuit is necessary because the amplitude of the error voltage varies with frequency. For the first six transmitter bands (1.5 to 9 mc), the error voltage is fed through contacts 6 and 3 (or 7) of switch S614B (rear) to the antenna network servo amplifier, without attenuation. For the last three bands (9 to 20 mc), the voltage is fed through the voltage divider composed of R608 and R609 and contacts 6 and 2 (and 7 or 3) of the switch to the antenna network servo amplifier.
- (4) By using a variable capacitor for C305, compensation for variation in circuit constants can be provided. However, under no circumstances should C305 be adjusted in the field. The adjustment of C305 can be done only at depots where sufficient test equipment is available.

77. Antenna Network Servo Amplifier

a. *Input Circuits* (fig. 49).

- (1) *Phasing section.* The output of the phasing discriminator is applied to the input circuit of the phasing servo amplifier. The filter composed of C901, R901, and C902 removes audio-frequency components which may be present in the error signal when the transmitter is modulated. The RC network composed of C903, R902, and R903 serves to stabilize the operation of the servo amplifier.
- (2) *Loading section.* The output of the loading discriminator is applied to the input circuit of the loading servo amplifier. The filter circuit of this section is composed of C911, R915 and C912. The stabilizing RC circuit consists of C914 and R916.
- (3) *Chopper G901.* Exciting voltage for the chopper is obtained from the 115-volt, 400-cps dynamotor. C921, C922, and C923 compensate for the slightly inductive loads presented to the 400-cps generator. R929 and C924 provide a 25° phase shift in voltage, which, added to the 65°

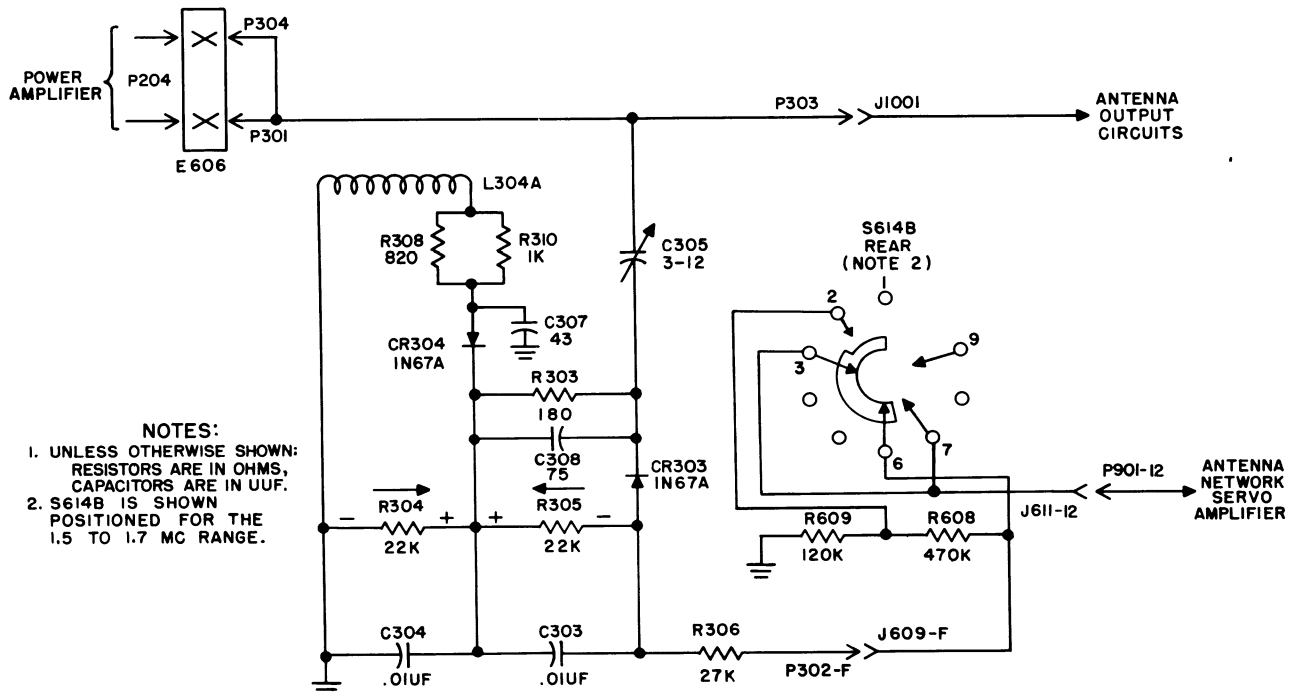

TM 806-45

Figure 48. Loading discriminator, functional diagram.

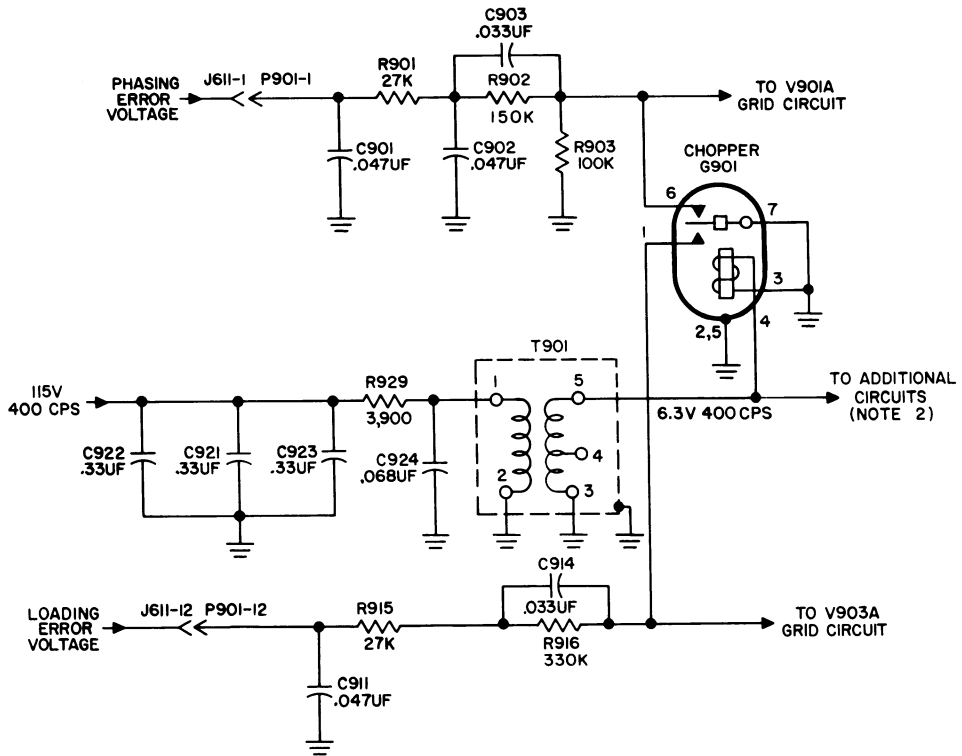

- NOTES:
1. UNLESS OTHERWISE SHOWN: RESISTORS ARE IN OHMS.
 2. SEE 115V 400 CPS VOLTAGE DISTRIBUTION.

TM 806-46

Figure 49. Antenna network servo amplifier input circuits, functional diagram.

phase shift obtained in the chopper, provides the 90° phase shift necessary for rotation of the servo motors (par. 93). Stepdown transformer T901 furnishes 6.3 volts ac to the coil of G901, which causes the grid input circuits of the phasing and loading amplifiers to be grounded alternately at a rate of 400 cps. This results in a 400-cps, squarewave voltage, proportional in amplitude to the dc error voltages applied to the input of each amplifier. Transformer T901 also furnishes 400-cps exciting voltage to power-amplifier chopper G201, and sidetone voltage to modulator sidetone amplifier V403A (par. 72).

b. Amplifying Circuits (fig. 50). Because the phasing and loading amplifying circuits are almost identical, the following description applies to both circuits. Each circuit converts the 400-cps square wave voltage to 400-cps sine wave voltage, of the proper phase and amplitude, for application to its associated servo motor.

- (1) The 400-cps square wave voltage, proportional in amplitude to the dc error

signal, is coupled by dc blocking capacitor C'904 to the input grid of phasing amplifier V901A. This stage utilizes one-half of a miniature dual-triode tube, type 5751. An rf filter, consisting of R904 and C'905, reduces the magnitude of the high frequency components of the square wave voltages which would upset the operation of the servo amplifier if applied to the control grid of V901A. Bias voltage for the tube is developed across grid resistor R905.

- (2) V901A amplifies the modified square wave voltage from the chopper and applies this amplified voltage to plate load resistor R906. Plate supply voltage is decoupled by R908 and C'918. Blocking capacitor C'909 couples the audio output of V901A to the control grid of second phasing amplifier V901B. R907 and R909 serve as grid leak and cathode bias resistors, respectively, for this tube. The decoupling network consists of R913 and C'908. R910 is the plate load resistor for V901B. Coupling capacitor C'907 and

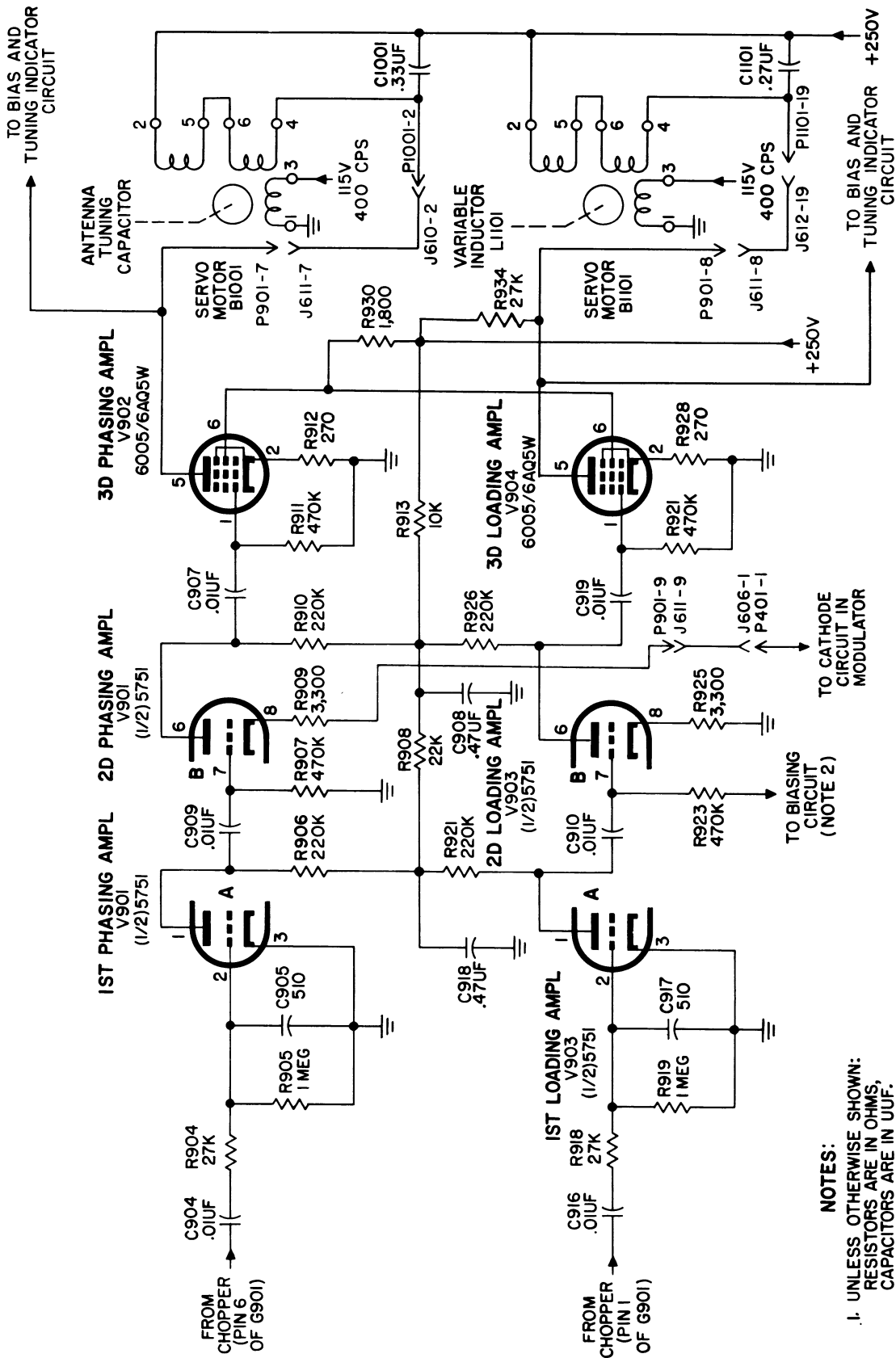

- NOTES:**
1. UNLESS OTHERWISE SHOWN: RESISTORS ARE IN OHMS, CAPACITORS ARE IN UUF.
 2. SEE ANTENNA NETWORK SERVO AMPL BIAS AND TUNING INDICATOR CIRCUIT.

Figure 50. Antenna network servo amplifier, amplifying circuits, functional diagram.

grid resistor R911 comprise the input circuit of third phasing amplifier V902. This tube is a miniature pentrode, type 600/6AQ5W. Cathode bias is generated across R912 to establish the proper operating point for the tube. A potential of +250 volts is applied to R930, which feeds voltage to the screen grid of V902.

Note. In the following explanation, it is assumed that grid resistor R923 of loading amplifier V903B is not connected to ground.

c. Output Circuits (fig. 51).

(1) The phasing and loading discriminators operate the antenna tuning capacitor and the variable inductor until the desired output conditions are obtained. Since adjustment of either the variable inductor or the antenna tuning capacitor will require a change in the other, some means must be found to prevent the possibility of constant adjustment and readjustment during the antenna tuning process. To

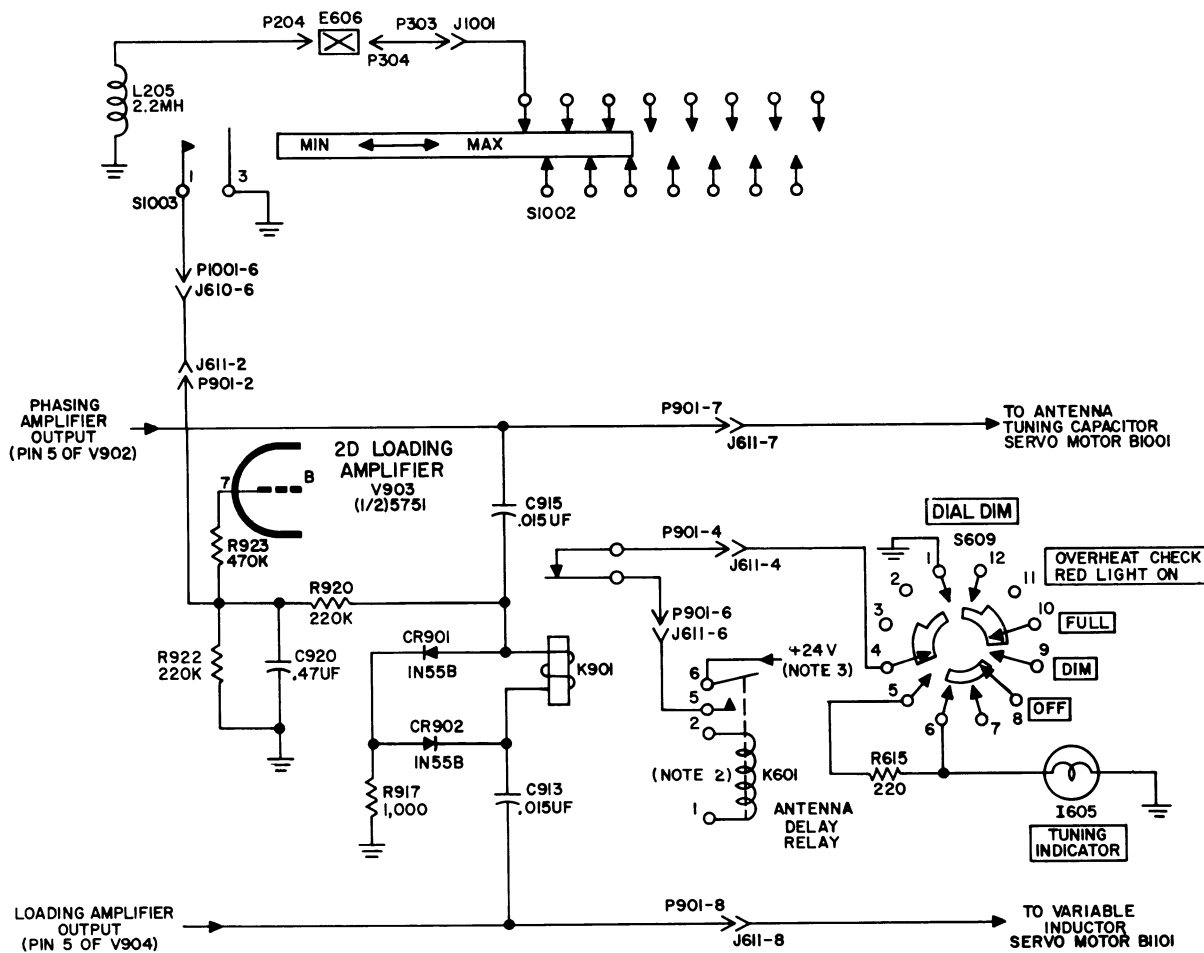

- NOTES:
1. UNLESS OTHERWISE SHOWN: RESISTORS ARE IN OHMS, CAPACITORS ARE IN UUF.
 2. K601 IS ENERGIZED BY KEYING RELAY K605.
 3. +24V IS SUPPLIED WHEN HV RELAY IS ENERGIZED.

TM 806-48

Figure 51. Antenna network servo amplifier, output circuits, functional diagram.

do this, the sensitivity of the loading amplifier is reduced while the phasing amplifier adjusts the antenna tuning capacitor.

- (2) A portion of the phasing amplifier output is coupled through C915 to the junction of C915 and R920. Positive portions of the ac signal are bypassed to ground through CR901 and R917. Negative portions of the ac signal are applied across K901, CR902, and R917. As a result of this action, a pulsating negative voltage appears at the junction of R920, CR901, and C915. The filtering action of C920 and R922 converts this voltage into a negative dc voltage which is applied to the grid of V903. This increased negative bias reduces the sensitivity of the loading amplifier. Unless a large error is present in the loading amplifier, the adjustment of the variable inductor will not be changed. When the phasing amplifier has completed the adjustment of the antenna tuning capacitor, the phasing error voltage is reduced to zero, the negative bias is removed from V903, and the loading amplifier is free to act.
- (3) When the antenna tuning capacitor is at its maximum or minimum position, the loading amplifier functions normally. This is accomplished by grounding the bias voltage through S1003 or S001.
- (4) Voltage from the phasing and loading amplifier is applied to the coil of K901 through C915 and C913. Rectification of the signals is accomplished through CR901 and CR902. The result of this rectification is that only a pulsating dc flows through the coil of K901, and, because of the polarization of CR901 and CR902, this current will flow in only one direction. Therefore, an error voltage appearing in the phasing or loading amplifier will open the contacts of K901 and prevent the TUNING INDICATOR from lighting. Whenever the key is depressed (activating K601) and no error voltage appears in the servos (indicating correct antenna tuning), the contacts of K901 will close and the TUNING INDICATOR will light.

78. Output Capacitor

(fig. 52)

Figure 52. Output capacitor, functional diagram.

(See Attached Envelope)

The purpose of the output capacitor is to decrease the high capacitive reactance of the antenna at the lower operating frequencies of the transmitter, and to increase the capacitive reactance of the antenna at the higher frequencies. At the center frequencies, the antenna tuning capacitor and the variable inductor are sufficient for phasing and loading of the antenna.

a. The proper output capacitor circuit is selected by S612A and S612B. These switch sections are controlled by output capacitor motor B603, which, in turn, is controlled by open-circuit seeking switches S614A (front and rear) and S101C (front and rear).

b. When the BAND SELECTOR is moved to a new band setting, a ground connection is established through S101C and S614A to the coil of motor switch relay K613. This energizes the relay that connects R605 through contacts 2 and 3 to contacts 2 and 11 of the SERVICE SELECTOR switch (S606A front). If S606 is in the CW position, contact 11 is connected to ground. If S606 is in the VOICE/FSK position, TEST KEY S603 must be closed to ground the circuit. Twenty-four volts is applied through contacts 2 and 3 of Autotune muting relay K609 to the positive side of B603, so that during the Autotune cycle, the circuit of B603 is disabled. If the Autotune cycle has been completed and the ground connection through S606 has been made, the motor will rotate, and thus cause the rotation of S612 and S614A.

c. Switches S612 and S614A each have 10 positions. When S612 is rotated, it selects the proper output circuit, depending on the position of the switch when the motor rotation is stopped. When S614A is rotated, it seeks to break the ground path present between S101C and terminal 5 of K613. The ground path can be broken in only one position of S614A for a given position of S101C. In figure 49, S101C is set to the 1.5- to 1.7-mc range, and S614A is shown properly positioned to break the ground path to K613. In all other positions of S614A the ground path is maintained. If S101C were moved, motor B603 would be energized and S614A would be rotated until the ground path was again broken. When the ground path to K613 is

broken, the relay is deenergized, and contact 3 is connected to the 24-volt supply, through contact 4, instead of to ground. This short circuits the

motor terminals to the 24-volt supply and provides a dynamic brake on motor B603 to prevent over-travel.

Section VII. ANTENNA SWITCHING AND KEYING CIRCUITS

79. General

The antenna switching and keying circuits are closely related and comprise one functional circuit. The purpose of this functional circuit is to provide the following effects:

- a. Blocked-grid keying for cw transmission.
- b. Power-amplifier protection between transmissions.
- c. Antenna switching between transmitter and receiver.
- d. Receiver disabling during transmission.
- e. Keying control.
 - (1) In normal and duplex operation, by an external key or microphone.
 - (2) In relay operation, by the receiver control circuits.
- f. A means of monitoring the transmitted signals.
- g. Continuous connection of transmitter to antenna during continuous keying, thus preventing distortion of keying waveform and damage to relays because of excessive operation.

80. Flow Chart

(fig. 53)

The flow chart of figure 53 shows the sequence of events when the key or microphone switch is closed. When the key or microphone switch is opened, an opposite set of conditions is set up in each block of the flow chart, with one exception: antenna delay tube V403 continues to conduct for a short period of time after the keying relay is deenergized. Therefore, during continuous keying, the circuits that are actuated by the conduction of V403, remain in a steady state of operation. The transmitted carrier signal is interrupted, however, since rf excitation is removed and the keying relay interrupts the negative bias applied to V202. This tube then conducts and drops the screen voltage on V201 (par. 63a).

81. Circuit Analysis

(fig. 54)

Figure 54. Antenna switch and keying circuits, functional diagram.

(See Attached Envelope)

In the following discussion, the application and removal of operating voltages during keying is not included (par. 88).

a. *Keying Relay Control.* The coil of keying relay K605 is energized by connecting one side of its coil to ground. This can be accomplished by the following circuits:

- (1) When TEST KEY S603 is operated, it connects K605 to ground through contacts 10 and 9 of S603 and current-limiting resistor R621.
- (2) When the microphone switch at the transmitter, receiver, or remote location is closed, it connects K605 to ground through R621, Z601, and one of the receptacles mounted on the front panel of the transmitter.
- (3) When S602 is in the RELAY position, K605 is connected to ground through R621; contacts 5 and 6 of S602; the rf filter composed of C612, L621, and C639; one of the receptacles mounted on the front panel of the transmitter; and the keying circuit located in the receiver.

b. *Sidetone Control.* The sidetone amplifier, V403A, is normally biased to the cutoff point by a negative voltage which is applied through R119, R406, and R436 to its control grid. When relay K605 is energized, the biasing voltage is grounded through R119 and contacts 7 and 6 of the relay. This removes the negative bias and allows the sidetone amplifier to operate (par. 72). Capacitor C404 provides rf filtering for the grid circuit of V403A.

c. *Blocked-Grid Keying.* The first multiplier tube, V101, the driver tube, V104, and the preamplifier tube, V401A, are normally biased to the cutoff point by the negative voltage applied to their respective grid circuits through R119. Capacitor C134 serves as an rf filter for this voltage, which is fed to the control grid of V101 through R120 and R101, to the control grid of V104 through R114, and to the control grid of V401A through R405 and R410. Capacitor C102 serves as an rf filter for the grid circuit of V101. When the keying relay is energized, the biasing

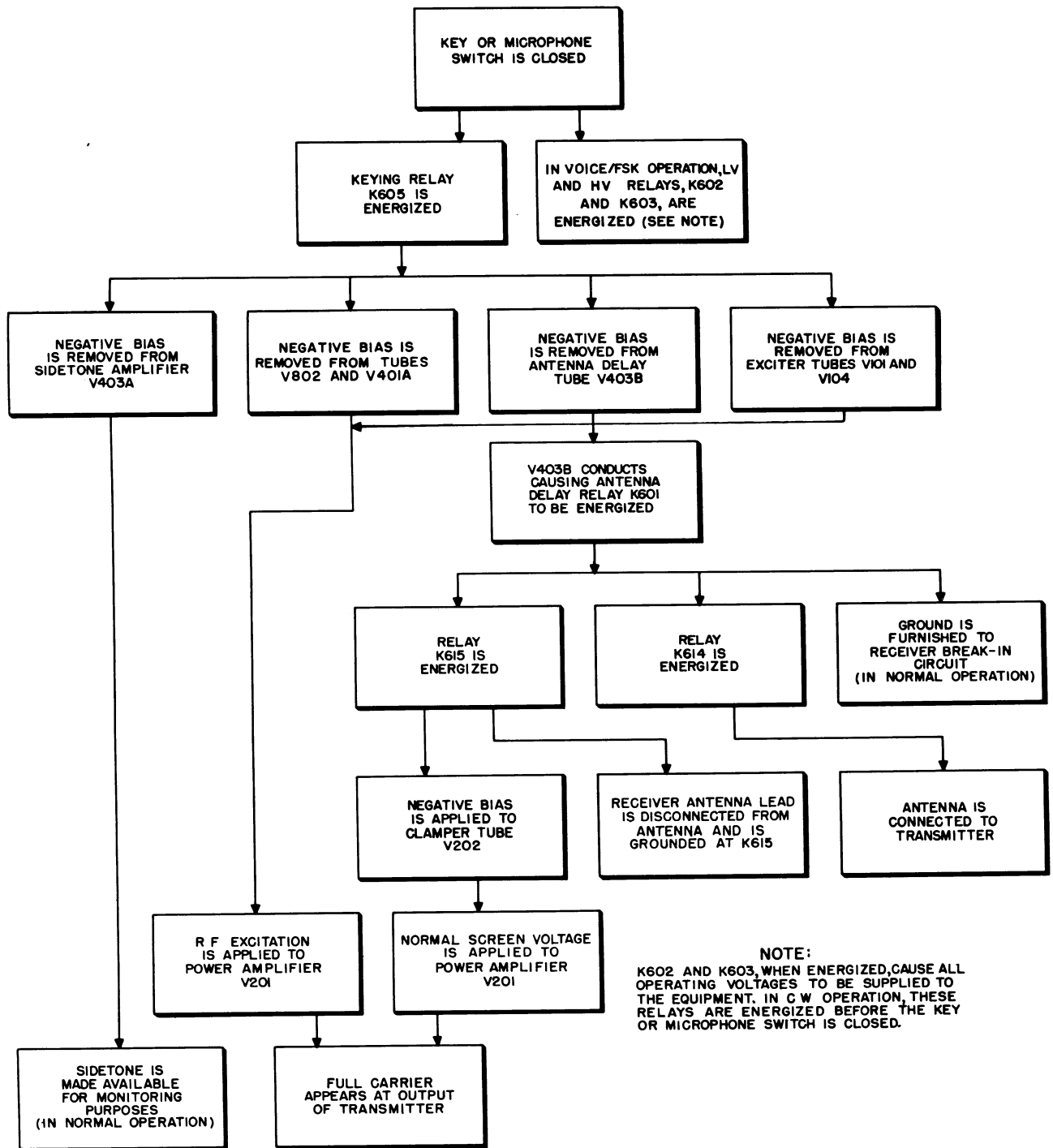

TM 806-50

Figure 53. Antenna switching and keying, flow chart.

voltage is grounded through R119 and contacts 7 and 6 of the relay. This removes the negative bias from V101, V104, and V401A; the exciter then functions to provide rf excitation to the grid of power amplifier V201, and the modulator supplies audio signals to the plate circuit of V201. (See pars. 56, 57 and 68 for complete tube circuits.) The buffer amplifier, V802, is also biased to cutoff between transmissions, by the suppressor grid connection to the biasing circuit of V403 (below). (See par. 53 for complete tube circuit.)

d. Antenna Delay.

(1) A negative bias is normally applied to the control grid of antenna delay tube V403B through the large resistance of R448, and the tube does not conduct. When the keying relay is energized, the control grid of V403B is connected to ground through current-limiting resistor R453 and contacts 4 and 5 of K605. This causes the grid to become less negative, and the tube conducts through plate resistor R626 and the coil of antenna delay relay K601 to the +250-volt supply. Current flow through the coil of K601 energizes the relay, and the following occurs:

- (a) If S602 is set to the NORMAL position, the receiver break-in circuit is connected to ground through contacts 9 and 10 of S602 and contacts 4 and 3 of K601.
- (b) A potential of +24 volts is applied through contacts 5 and 6 of K601 to R610 and the coil of K615, and through contacts 5 and 6 of K615 to K614. When K615 operates, the high starting current to K614 is broken, and the voltage is fed to K614 through R610 only. This prevents too high a current flow through the coil of K614. At this time, both relays are energized.

1. When K614 is energized, WHIP ANTENNA receptacle J615 or 50 OHMS OUTPUT receptacle J614 is connected to the transmitter output circuits, and RECEIVER ANTENNA receptacle J616 is disconnected.

2. When K615 is energized, RECEIVER ANTENNA receptacle J616 is grounded.

3. A negative bias is applied through contacts 3 and 2 of K605, contacts 4 and 3 of K615, S203, and K202 to the control grid of clamper tube V202. Cam switch S203 prevents application of negative bias to the clamper during band switching, and K202 removes the bias when current through the power-amplifier tube becomes too great (par. 63b). The bias voltage drives the clamper tube to cutoff, which increases the screen voltage applied to the pa tube (par. 63). Resistor R229 is the grid resistor and, with C208, controls wave-shaping (par. 63b).

(2) When the key or microphone switch is closed and antenna delay tube V403B is conducting, C424 charges to the value of voltage applied to the control grid. When the key or microphone switch is opened, thus deenergizing K605, R453 is no longer connected to ground, and the voltage applied to the grid of V403B becomes more negative. Capacitor C424, however, requires time to charge through R448 and draws current until fully charged. This means that the grid bias does not cut off V403B immediately after K605 is deenergized; the tube will continue to conduct for the amount of time C424 requires to become fully charged. Relays K601, K614, and K615 remain energized while the tube is conducting, and if the keying relay is energized again before C424 becomes fully charged, the relays will remain energized.

e. Power-Amplifier Protection. When keying relay K605 is deenergized, negative bias is removed from the control grid of clamper tube V202. The tube then operates to reduce the screen voltage to power-amplifier tube V201. This prevents excessive current from being drawn through V201 which would damage the tube or its associated circuits (par. 63).

Section VIII. AUTOTUNE SYSTEM

82. General

The operating frequencies of Radio Transmitter T-195/GRC-19 are determined by the position of tuning cores and band switches. These tuning devices are controlled by an electromechanical system which provides for both automatic and manual tuning. Eight automatically tuned channels are available, each of which is preset manually to a desired channel frequency. When a preset channel is selected, the Autotune system adjusts the tuning cores and band switches to provide the desired operating frequency. One of the eight Autotune channels is designated for manual tuning, but may be preset for automatic tuning.

Note. For manual tuning or presetting, the Autotune positioning heads are unlocked. The Autotune system must not be operated while in this condition, since channel settings for all channels will probably be lost. Tighten the locking key before Autotune operation.

The Autotune control circuits, which form the electrical part of the system, are used to control the multiturn and single turn positioning heads that comprise the mechanical part of the system. A schematic diagram of the Autotune control circuits, mechanical representation illustrations of the single turn and multiturn positioning heads, and a flow chart, (fig. 58) which shows the sequence of events during Autotune operation is provided for use with the following paragraphs.

83. Autotune Control Circuit

(fig. 55)

Figure 55. Autotune control circuits, functional diagram.

(See Attached Envelope)

The Autotune control circuits properly position the multiturn and single turn positioning heads, so that the desired set of operating conditions are set up in the transmitter. The positioning heads are initially adjusted to provide eight sets of conditions (frequency settings), each of which corresponds to one of the eight positions of PRESET CHANNELS switch S604. The Autotune control circuits perform a complete cycle of operation each time the Autotune cycle is initiated, regardless of the frequency channel selected. The operation is as follows:

a. Switches S604 and S605 are connected so that when S604 is in any position, S605 must be in a corresponding position to break a ground path

through their connecting leads. Because during a previous Autotune cycle, S605 has been adjusted to S604 so that the ground path through the switches is broken, the rotation of S604 to a new channel position will re-establish the ground path. This ground path is maintained in any one of seven positions of S605, through switches S604, and S606, and through S605 to limit switch S617. Switch S606 connects S605 to a channel switch in Transmitter Control C-822/GRC-19 when S606 is in the REMOTE position, and to S604 when S606 is not in the REMOTE position. The ground connection to S617 initiates the Autotune cycle; to complete the cycle S605 must be finally rotated to the one position which breaks the ground path to S617.

b. Limit switch S617 is composed of two microswitches which are operated by an actuating arm, the movement of which is controlled through a slip clutch and lost motion drive by Autotune motor B601. Figure 55 shows the limit switch when the Autotune cycle has been completed. When a ground connection is supplied to S617, contacts 3 and 4 connect the ground to terminal 1 of Autotune relay K610, 24 volts are connected to terminal 2 of K610, and the relay is energized.

c. When K610 is energized, the following occur:

- (1) Alternate ground connections are provided for terminal 1 of K610 through contacts 7 and 8 of K610, contacts 6 and 5 of S617, contacts 5 and 6 of K610, and open-circuit seeking switches S604 and S605.
- (2) A potential of 24 volts is applied to terminal F1 of B601 through contacts 4 and 3 of K610, and to terminal A1 of B601 through contacts 4, 3, 9, and 10 of K610.
- (3) A ground connection is made through contacts 12 and 13 of K610 to terminal A2 of B601.
- (4) Autotune muting relay K609 is energized; this disables the output capacitor selection circuit, the homing circuits, and the high-voltage circuits until after the Autotune cycle is completed (fig. 61).

d. The voltage and ground connections to Autotune motor B601 (*c*(2) and (3) above) energize

the motor, the rotation of which provides the occurrences listed in (1) through (3) below.

Note. During the Autotune cycle, the motor rotation is in either of two directions. For explanation purposes, they will be referred to as the first and the second directions.

- (1) S605 is mechanically connected to B601 through a ratchet drive that rotates S605 when the motor rotates in the first direction. (S605 has no stops, and rotates continuously in one direction.)
- (2) B601 drives the actuating arm of S617 through a lost motion drive and slip clutch. The lost motion drive permits 1 complete revolution of S605 before it engages the switch (S617) side of the drive, so that contacts 5 and 6 of S617 maintain a ground connection to the coil of K610 when S605 passes the one position that breaks the ground path through S605 and S604. When the lost motion drive is engaged, the actuating arm of S617 is driven so that contacts 3 and 4 are opened, and 1 and 2 are closed (because of a spring-return mechanism). The motor continues to rotate in the first direction until contacts 5 and 6 of the limit switch S617 are opened. This breaks the ground path through S617 to the coil of K610, and leaves one remaining ground path through S604, S605, and contacts 6 and 5 of K610 to the coil. At this time the clutch slips and the motor continues to rotate in the first direction.
- (3) The motor continues to rotate until S605 is at the position that breaks the ground path to relay K610. When this occurs, relay K610 becomes deenergized. Cam switch S616 is synchronized with S605 so that a ground connection is maintained to K610 until S605 is in the exact center of its open position. This ensures precision control of the Autotune positioning heads.

e. When relay K610 is deenergized, the polarity of the voltage applied to terminals A1 and A2 of motor B601 is reversed. Twenty-four volts are applied to terminal A2 through contacts 2 and 1 of S617, and through contacts 14 and 13 of K610; terminal F1 receives 24 volts through contacts 2 and 1 of S617. The reversal of voltage polarities at terminals A1 and A2 reverses the direction of

rotation of the motor, and the motor then rotates in the second direction. This produces the following effects:

- (1) S605 remains stationary because of the ratchet drive, and the lost motion drive rotates in the second direction. The lost motion drive must make a complete revolution before the switch (S617) side of the drive is engaged and the actuating arm is moved in the second direction.
- (2) When the actuating arm of S617 is moved, contacts 5 and 6 close, but this has no effect on the circuits because contacts 8 and 7 of K610 are not connected.
- (3) The motor continues to rotate until the actuating arm of S617 opens the connection between contacts 1 and 2, and connects contacts 3 and 4 of the switch together. This removes the 24 volts from the Autotune motor, and the Autotune control circuits are again in their original state, except that S605 and S604 are positioned at the new preset channel.

Note. The sequence of events described above provides for the proper adjustment of the positioning heads. When B601 rotates in the first direction, the positioning heads are prepared for final adjustment, which is performed when B601 rotates in the second direction.

84. Single Turn Positioning Head

(fig. 56)

The first and second directions of rotation mentioned in *a* through *f* below correspond in time and direction to those mentioned in paragraph 83. Figure 56 is a simplified diagram of the single turn positioning head, the operation of which is as follows:

a. Autotune control motor B601 drives worm gear 1 in the first direction so that gear 2 rotates in the direction indicated by the solid arrow (fig. 56). Gears 2 and 3 are fastened together, and rotation of gear 2 causes rotation of cam drum 7 through gears 3, 5, and 6, and ratchet drive 8.

b. A clutch action exists between gear 2 (and 3) and shaft 4. Stop-ring drum 9 rotates in the first direction until rotation stop 10 halts the shaft rotation, and the clutch slips. Cam drum 7 continues to rotate until the Autotune motor reverses direction (par. 83).

c. Cam drum 7 is composed of eight slotted rings, the slots of which are evenly spaced around the drum so that each slot corresponds to a position

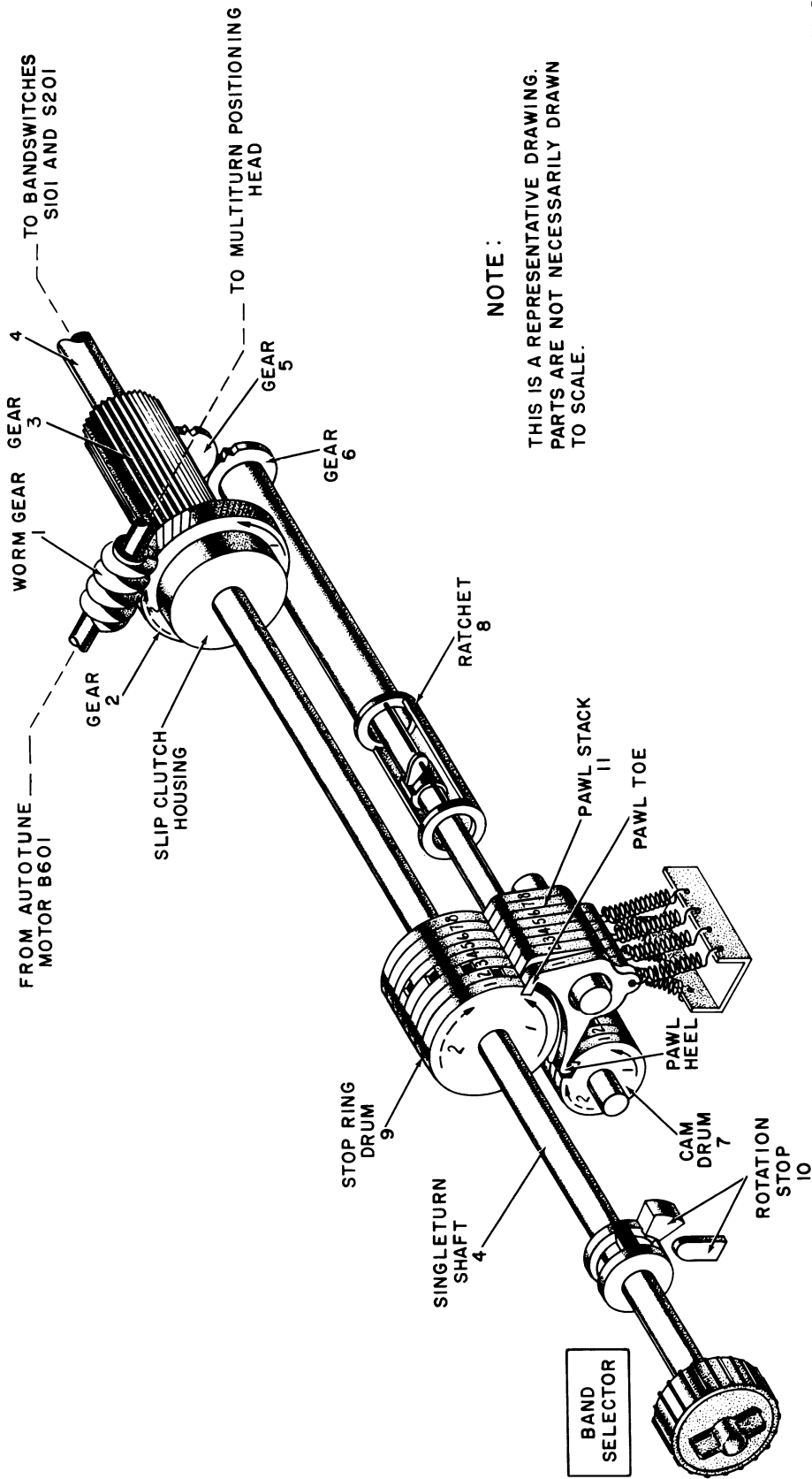

Figure 56. Single turn positioning head, simplified drawing.

of switch S605 in the Autotune control circuits; ring 1 is synchronized with the first position of S605, etc. Pawl stack 11 is composed of eight pawls, each of which has a heel and a toe. The pawl heels ride on their corresponding cam drum rings; this keeps the pawl toes in a back position and does not allow the toes to fall into the slots on stop-ring drum 9. The pawl heels are tapered, so that when the cam drum rotates in the first direction, the heels fall partly into their respective slots, but ride out of the slot as the drum continues to rotate. If, in the first direction, a pawl toe falls into its slot on the stop-ring drum, the cam drum rotation will cause the pawl heel to ride out of the cam drum slot and thus raise the heel and disengage the toe from the stop ring. At the beginning of the Autotune cycle, one of the pawl toes is engaged in its respective stop ring, and during the first half-cycle of Autotune operation, the stop ring becomes disengaged, or cleared, in preparation for the second half-cycle.

d. The position of S605 in the Autotune control circuit, when it causes Autotune motor B601 to reverse direction, determines which cam drum ring is positioned, so that its slot is directly beneath its respective pawl heel.

Note. The rotation of the cam drum is identical with that of S605. The cam drum rotates continuously in the first direction only, in a manner similar to that of S605. When B601 reverses to rotate in the second direction, the cam drum remains stationary because of ratchet drive 8.

e. Shaft 4 can rotate in the second direction until rotation stop 10 is engaged; this limits the rotation of shaft 4 and stop ring drum 9 to approximately three-fourths of a turn. This means that when the stop ring drum is rotated, three-fourths of its circumference will pass the pawl toes. The stop rings are preadjusted so that during the rotation all of the stop ring slots pass beneath the toes. When a stop ring slot moves under the pawl toe which has been released by its corresponding pawl heel, the toe will fall into the slot, and the stop ring drum and shaft 4 will be held stationary. Because band switches S101 and S201 are mechanically linked to shaft 4, they will be positioned according to the setting of the stop ring slot which has engaged its pawl toe. Autotune motor B601 will continue to rotate (in the second direction), but the clutch will slip, and shaft 4 will not be moved.

f. For the initial channel frequency setting, a key on the BAND SELECTOR knob is loosened,

which allows an engaged stop ring to slip on shaft 4. The other seven stop rings maintain their relative position to each other and the shaft, so that when the BAND SELECTOR knob is rotated (manually), seven stop rings, the shaft, and the band switches are rotated. The engaged stop ring is held stationary, and the frequency band setting at which the BAND SELECTOR is set becomes the new band setting for that stop ring. When the key is locked, all stop rings are fastened securely to each other and the shaft.

85. Multiturn Positioning Head (fig. 57)

Figure 57. Multiturn positioning head, representative drawing.

(See Attached Envelope)

The multiturn positioning head is controlled simultaneously with the single turn head, so that the directions of rotation (first and second) correspond to those in paragraphs 83 and 84. The principles of operation are basically the same as those for the single turn head, in that the cam drum is rotated to disengage the stop-ring drum, which is then rotated during the first half-cycle to a *home* or starting position. The cam drum in the multiturn head is synchronized with S605 and the single turn head cam drum, so that it is properly positioned when S605 causes a reversal of the Autotune motor rotation. The multiturn head, however, differs from the single turn head in that it must control tuning devices which require several rotations. For this reason, an additional drum (known as the counter drum), which permits the controlling shaft to rotate several times before the stop ring drum is engaged by its pawl toe, is used. The operation of the multiturn positioning head is as follows:

a. Autotune control motor B601 drives worm gear 1 in the first direction, which causes cam drum 2, mounted on shaft 3, to be rotated through the action of gears 4, 5, 6, 7, and 8, and ratchet drive 9 in the direction indicated by the solid arrow (fig. 57). The pins of gear 6 pull pawl-lifter lever 10 back, thus rotating pawl-lifter arm 11, which in turn rotates pawl-lifter shaft 12. The rotation of shaft 12 lifts all pawls of pawl stacks 13 and 14 away from the drums, allowing the drums to rotate. Cam drum 2 rotates continuously until the Autotune motor reverses direction, leaving the drum positioned so that the cam drum slot cor-

responding to the channel selected is directly beneath its respective pawl heel.

b. Stop-ring drum 18, mounted on shaft 17, is driven by the action of gears 1, 4, 15, and 16. Slip clutch action exists between shaft 17 and gear 16. Counter drum 19 is rotated by gear 20, mounted on shaft 17, through the action of gears 21, 22, 23, sun gear 24, and planetary gear 25, which is attached to the counter drum. Small planetary gear 25 rides between sun gear 24 and ring gear 26. This arrangement results in the counter drum rotating 10 times more slowly than the stop ring drum. Gear 27 is coupled to sun gear 24, and drives gear 28 at approximately the same speed as the counter drum. The pins on gear 28 limit the rotation of shaft 17 to 10 turns. During the rotation in the first direction, one of the pins eventually pushes stop anchor assembly 29 to draw rod 30 backward, and rotates home-stop pawl 31, so that home stop 32 becomes engaged. This stops the rotation of shaft 17, thereby stopping the rotation of the stop-ring drum and the counter drum. When this occurs, clutch 3 slips until the motor reverses its direction.

c. When S605, in the Autotune control circuits, causes the Autotune motor to reverse direction, cam drum 2 is left stationary because of the action of ratchet drive 9. The pins of gear 6 now push pawl-lifter lever 10 forward, which rotates pawl-lifter arm 11 so that the flat surface of shaft 12 is turned up, thereby releasing the pawls so that they can operate normally. The pawl heel corresponding to the channel selected enters the cam drum slot, allowing the pawl toe to ride against the corresponding counter drum ring. Gear 34 is friction-coupled to the counter drum, and is driven through gears 20, 21, and 35. Normally, gear 34 slips against the counter drum, except during the short interval that the pin on ring gear 26 is free to travel between the arms of stop 36. During this short interval, gear 34 rotates the counter drum at an increased rate of speed until stop 36 halts the rotation of gear 26, and gears 24 and 25 again control the rotation of the counter drum. When rotation is reversed in either direction, this arrangement advances the counter drum slot slightly ahead of the stop ring drum to allow the pawl toe of the counter drum to enter its slot just before the pawl toe of the stop ring drum passes over the slot. This permits manual tuning in either direction.

d. When the Autotune motor rotates in the second direction, the pawl toe of pawl stack 14 rides against its counter drum ring until the slot in the ring passes under it. Because the counter drum rotates at one-tenth of the speed of shaft 17, the stop-ring drum may rotate several times before the counter drum is engaged by the pawl toe. The counter drum slots are longer than those of the stop-ring drum, and when the pawl toe enters the slot in the counter drum ring, the rotation continues for a short time. During this time, the pawl toe of pawl stack 13 rides against its ring on the stop drum until the toe enters its slot. When this happens, rotation of shaft 17 is stopped and the tuning cores of the master oscillator and exciter subchassis are positioned accordingly.

e. A key on the TUNING CONTROL knob is loosened for initial frequency setting, allowing the engaged stop ring to slip on the shaft (par. 84). During manual tuning in the second direction, a limit rotation is established by a pin on gear 28, which operates the stop mechanism to push rod 30 forward. This rotates home stop pawl 31 so that home stop 32 is engaged, stopping the rotation of shaft 17.

86. Summary of Transmitter Tuning (fig. 59)

a. The flow chart of figure 59 gives the sequence of events when a new operating channel is selected by the operator. When the PRESET CHANNELS switch is moved to a new position, and the SERVICE SELECTOR switch is in any position other than OFF, the Autotune system will function. If the SERVICE SELECTOR switch is in CALIB or STAND BY position, the output capacitor selection and homing circuits will not function. If the SERVICE SELECTOR switch is in CW or VOICE/FSK position, the circuits will function as described in the flow chart. It can be seen from the chart, that each tuning operation must be completed before the succeeding circuits can function. When the TUNING INDICATOR lamp is lit, the transmitter is completely tuned, and is transmitting rf energy.

b. The following information summarizes the action resulting from the movement of the frequency controls in the VOICE/FSK position:

- (1) Move BAND SELECTOR from (1.7–2.0) to (3.0–4.0).
 - (a) Exciter band switch is rotated.
 1. Selects output capacitor position.

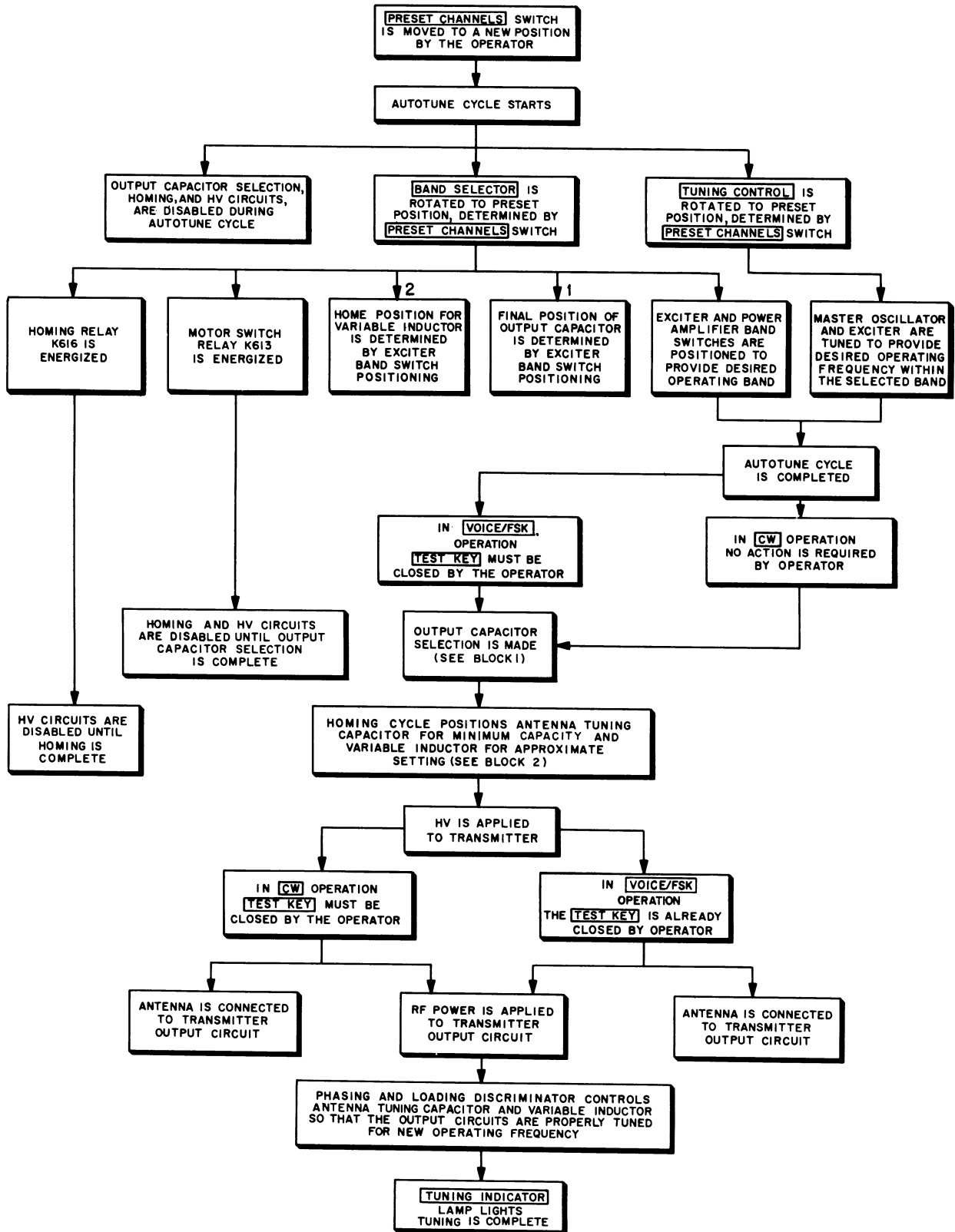

TM 806-122

Figure 59. Complete tuning cycle, flow chart.

- 2. Selects variable inductor homing position.
 - (b) Pa band switch is rotated.
 - (c) Selects proper BAND SELECTOR dial position.
 - (d) Selects proper counter mask position.
 - (e) Momentarily closes S-203. Homing relay K616 is operated.
- (2) Move TUNING CONTROL from 1.790 to 3.800.
 - (a) Rotates mo shaft.
 - (b) Rotates frequency counter.
 - (c) Positions exciter slug rack.
 - (d) Transmitter automatically tunes and loads.
 - (e) TUNING INDICATOR lights.

Section IX. POWER CIRCUITS AND SERVO MOTORS

87. General

Primary power for Radio Transmitter T-195/GRC-19 is supplied from a 24-volt source which is capable of delivering at least 42 amperes of current. Operating voltages for the transmitter are supplied by two dynamotors which are mounted in the transmitter. The flow chart (fig. 60) shows the general relationship of the main parts of the power circuits, and, paragraphs 88 through 93, and figures 60 through 64 give more detailed information on these circuits.

88. Distribution, 24-Volt

(fig. 61)

Figure 61. 24-volt distribution, functional diagram.

(See Attached Envelope)

The primary power of Radio Transmitter T-195/GRC-19 is 24 volts dc. The positive line is connected to the transmitter through pins A and B of the 24 VOLTS DC receptacle, J605; the negative line is connected through common pins C and D of J605 to chassis ground. Pin A of J605 is connected to pin D of the RECEIVER CONT receptacle, J604, to furnish primary power for Radio Receiver R-392/URR. The 24-volt input to the transmitter is fed through the capacitor-input-filter circuits of Z601 to fuses F601, F602, and F603.

a. Filament Start Relay. Twenty-four volts are applied through 15-ampere fuse F601 to terminal 2 of relay K608. The other side of the relay coil (terminal 1) is connected through CR602 to contact 3 on K608, contact 11 on S606A (rear), and contact 8 on S606C (front). Contact 4 of K608 is connected to terminal 2 S606A (rear) through cabinet thermostat S608. Contact 4 of S606A (rear) connects to ground through the plugs and receptacles of the antenna-tuning capacitor subchassis, the variable inductor subchassis, and the power amplifier subchassis, blower thermostat

S610, and blower thermostat S202. This arrangement prevents operation of the equipment with any one of the three subchassis disconnected. When SERVICE SELECTOR switch S606 is rotated from the OFF position, relay K608 is energized and voltage is applied through contacts 2 and 8, and contacts 9 and 10 of K608 to the following circuits:

- (1) *Blowers.* Twenty-four volts are applied to exhaust blower B602 through contacts 9 and 10 of K608 and the line-filter circuit composed of C622 and L614. Twenty-four volts are also applied through contacts 2 and 8 of K602 and through J608-13 and P201-13 to power-amplifier blower B202. If B202 should become defective, or if insufficient cooling air is delivered to the plate of V201, blower thermostat S202 deenergizes K608 and removes all power from the transmitter. When K608 is deenergized, 24-v dc is applied through normally closed contacts 5 and 6 of K608, through S60C (rear) contacts 10 and 11, through S609 contacts 5 and 7, and through R615 to the tuning indicator I 605. When S609 is operated to the OVERHEAT CHECK RED LIGHT ON position after a thermal overload, tuning indicator I 605 will light. Capacitors C249, C209, C210, L206, and R239 serve as a line filter for B202.

(2) *Filaments*

- (a) Filament power is supplied through contacts 7 and 8 of K608 to V801, V802, V203, V204, V901, V903, V904, V902, V404, V401, V403, and V402. Twenty-four volts from contacts 7 and 8 of K608 are connected through R611, J617-C to P802-C to filaments of V802 and V801 in series. Capacitor C632 is an rf filter for this 24-volt circuit.

Twenty-four volts are connected through J608-13 and P201-13 to the filament of V203, V204, and R235 in series. Shunt current resistor R234 is connected in parallel with R235 and V204. Twenty-four volts are connected through J611-15 and P901-15 to V901, V903, and R931 in series. Twenty-four volts are connected through J611-15 and P901-15 to V904, V902, and R932 in series. Twenty-four volts are connected through J606-18 and P401-1, through R412, V404, V402, V401, and V403 to ground. Shunt current resistor R417 is connected in parallel with V402, V401, and V403. Thermostat S801 provides compensation whenever the surrounding temperature falls below 0° C. At this time, the thermostat contacts close, and 24 volts are applied to the heater element. Heat resulting from the current flow through the element raises the surrounding temperature, and the contacts open. Capacitor C812 serves as a spark suppressor for the contacts of S801.

- (b) Filament power is supplied through contacts 9 and 10 of K608 to V202, V101, V102, V103, and V104. Twenty-four volts from contacts 9 and 10 of K608 are connected through J607-11, P101-11 to V101, V102, V103, and R123 in series. Shunt current resistor R121 is connected with V102, V103, and R123. Twenty-four volts from contacts 9 and 10 of K608 are connected through J607-11 and P101-11 to V104, through P101-14, J607-14, R617, R616, J608-8, P201-8, and V202 in series.
- (c) Filament voltage is supplied to V201, V406, and V407 from two separate sources. During periods of standby, twenty-four volts from contacts 9 and 10 of K608 are connected to R623, R622, J608-2, P201-2, and V201. A parallel connection is made from J608-2 to J606-20, P401-20, and to V406 and V407 in parallel. This places all three tubes in parallel with their total filament current drawn through the voltage dropping resistors R623 and R622.

This arrangement provides approximately 20 percent reduction of filament voltage for the power amplifier tube and the two modulator tubes. During periods of operation, twenty-four volts are supplied through contacts 4 and 5 of 1v relay K602, F602, CR601 (a high current silicon diode) to the filaments of V201, V406, and V407 in parallel. This arrangement allows full filament voltage to be applied to all three tubes during operation and reduced voltage to be applied to these tubes during standby. Back resistance of CR601 isolates the 24-volt filament voltage from the dynamotor during standby.

- (3) *Discriminator relay K201.* When the BAND SELECTOR control is set for operation in the 1.5- to 6-mc range, this relay is energized by completing the coil circuit to ground through S101D (front).
- (4) *Transformer shorting relay K203.* When the SERVICE SELECTOR switch is set to the VOICE/FSK position, this relay is energized by completing the coil circuit to ground through contacts 4 and 5 of S606B (rear).
- (5) *Test meter M602.* Twenty-four volts are applied to current-limiting resistor R614, and when TEST METER switch S607 is set to the BATT position, the voltage is applied to the meter through contacts 10 and 8 of the switch. The negative side of M602 is connected to ground through contacts 2 and 4. The meter then indicates the value of input voltage to the transmitter.
- (6) *Frequency dial lamps.* Twenty-four volts are fed to contact 8 of DIAL DIM switch S609. When this switch is rotated to the DIM position, connection is made between contacts 8 and 9; and lamps I 602, I 603, and I 601 are connected in a series arrangement, each lamp receiving 8 volts. When S609 is set to the FULL position, connection is made between contacts 1 and 12; and contacts 8, 9, and 10 are connected together. This connects the lamps in a parallel arrangement, and each lamp receives 24 volts. When a thermal overload occurs, filament start relay K608 is deenergized by

operation of one of the protective thermostats S202, S608, or S610. Operating S609 to OVERHEAT CHECK RED LIGHT ON position connects 24 volts through normally closed contacts 5 and 6 on K608, contacts 10 and 11 on S606C (rear), and contacts 6 and 7 on S609 to tuning indicator I 605.

- (7) *Keying relay K605.* Twenty-four volts are applied to terminal 1 of the relay coil, which is energized when the TEST KEY, or an external key or microphone switch, connects terminal 8 of K605 to ground through R621. The relay is also energized when S606 is set to the CALIB position.
- (8) *Motor switch relay K613.* Twenty-four volts are applied to terminal 1 of the relay coil, which is energized when terminal 5 finds a path to ground through open-circuit-seeking switches S614A and S101C. This occurs when the BAND SELECTOR control is moved to a new position (par. 49).
- (9) *Homing relay K616.* Twenty-four volts are applied to terminal 1 of the relay coil, which is energized when terminal 10 is connected to ground through the homing circuits. This occurs when the BAND SELECTOR control is moved to a new position.
- (10) *Autotune relay K610.* Twenty-four volts are applied to terminal 2 of the relay coil and to the Autotune circuits. Terminal 1 of K610 is grounded through the Autotune circuits.
- (11) *Voice relay K402.* Twenty-four volts are applied to terminal 1 of the relay coil, which is energized by connecting terminal 6 to ground through contacts 4 and 5 of S606B (rear) when the SERVICE SELECTOR switch is set to the VOICE/FSK position.

b. Time-Delay Relay K403. When contacts 3 and 4 of filament start relay K608 close, 24 volts is applied to thermal time-delay relay K403. This relay delays application of power to the dynamotors and to certain circuits to allow a warmup period of 40 seconds for tube filaments. When contacts 5 and 7 of relay K403 close, voltage is applied through cabinet interlock S611 to the following circuits.

- (1) *Low-voltage relay K602.* Twenty-four volts are applied to terminal 1 of the relay coil, which is energized when terminal 2 is connected to ground through S606A (front). When SERVICE SELECTOR switch S606 is set to the CALIB or CW position, a ground path is provided through contacts 1 and 12 of S606A (front). When S606 is set to the STANDBY position, K602 cannot be energized. In the VOICE/FSK position of S606, the relay is energized by TEST KEY S603, which provides a ground path to the relay coil through its own contacts (9 and 10), and contacts 9 and 10 of S606A (front).

Note. The TEST KEY is connected in parallel with the external key or microphone switch; therefore, either the TEST KEY, external key, or microphone switch will control the low-voltage relay. When the low-voltage relay is energized, 24 volts from the power source is applied through J605-A, capacitor-input filter of Z601, the series winding of the relay, contacts 5 and 4 of the relay, and 10 ampere fuse F602 to low-voltage dynamotor D601. The series winding (terminals 3 and 5) of K602 prevents damage to the relay contacts. When the relay contacts close, the high surge current flowing through this series coil keeps the contacts closed until the dynamotor has come up to speed and the input current has dropped to a safe value. When energized, D601 furnishes 115 volts at 400 cps, +250 volts, and -45 volts as operating voltages for the transmitter. Choke L623 is provided in the +250-volt output line of the dynamotor as an rf line filter.

- (2) *Output capacitor motor (B603).* Twenty-four volts are applied through the normally closed contacts of Autotune muting relay K609 to B603 and to contact 4 of motor switch relay K613. When relay K613 is energized, the negative side of the motor is connected, through current-limiting resistor R605 and contacts 3 and 2 of K613, to contact 2 and 11 of S606A (front). In the CW position of the SERVICE SELECTOR switch, the motor circuit to ground is completed through contacts 11 and 12 of the switch. In the VOICE/FSK position, contact 11 is connected to contact 9 and 10 so that in this position of S606, the TEST KEY (or external key or microphone switch) must be closed to energize

the motor. When the motor rotates open-circuit-seeking switch S614A to a position that will break the ground circuit of K613 (*a*(8) above), the relay becomes deenergized and the ground circuit to R605 is broken.

- (3) *Homing circuits.* Twenty-four volts are applied to contact 3 of homing relay K616 through the normally closed contacts of Autotune muting relay K609 and motor switch relay K613. When homing relay K616 is energized, the voltage is distributed as follows:
 - (a) Voltage is applied through dropping resistor R620 and contacts 7 and 8 of K616 to the phasing servo amplifier. This voltage is used to rotate the antenna-tuning-capacitor motor during homing.
 - (b) Voltage is removed from terminal 1 of hv relay K603.
 - (c) Twenty-four volts are applied through contacts 4 and 3 of K616 to motor reversing relay K617. This relay controls the polarity of the voltage applied to homing motor B1102. Reversing switch S1101B controls the action of K617, and motor disabling relay K604 disables servo motor B1101 during homing (par. 75). Capacitor C644 prevents arcing between contacts 3 and 4 of K616 when power is applied to or removed from homing motor B1102. R1101 is a current-limiting resistor for motor B1102.
- (4) *High-voltage relay K603.* Terminal 2 of K603 is connected to contacts 2 and 11 of S606A (front). In the VOICE/FSK position of S606, terminal 2 of K603 is connected to ground through contacts 11 and 9 of S606A (front) and the test key S603 or external key or microphone switch. When the Autotune cycle has been completed, the antenna-output-capacitor selection has been made, the homing cycle has been completed, and K616 is deenergized, 24 volts is applied to terminal 1 of K603 through contacts 2 and 3 of K609, 4 and 3 of K613, and 3 and 2 of K616. This energizes the high-voltage relay K603. When the switch is set to the CALIB or STANDBY posi-

tion, the ground connection cannot be made, and high voltage cannot be applied to the equipment. When the coil of K603 is energized and thus closes contacts 4 and 5, voltage is applied through the relay contacts, the series winding of the relay, and 30 ampere fuse F603 to high-voltage dynamotor D602. The series winding of K603 (terminals 3 and 5) acts in the same manner as that of the low-voltage relay to protect the relay contacts from damage caused by arcing ((1) above). The hv dynamotor supplies +1,000 volts to the plates of the type 4X150D tubes in the modulator and the power-amplifier subchassis. The filter circuit composed of C659, C623, L602, and L610 removes ripple voltages from the +1,000-volt output. The input voltage of D602 is also applied through the contacts of antenna delay relay K601 (when keying relay K605 is energized) to antenna switching relay K614 and receiver antenna relay K615. To prevent arcing in the relay contacts, a set of contacts (5 and 6) on relay K615 provides a high starting current to the coil of K614. Both relays operate together; when they are energized and the contacts of K615 open, voltage is applied only through current-limiting resistor R610 to the coil of K614.

89. Distribution, 115-Volt, 4001 Cps (fig. 62)

The low-voltage dynamotor, D601, supplies 115 volts at 400 cps to the circuits shown in the functional diagram (fig. 62). The input circuit to D601 is shown in figure 61.

a. To furnish excitation voltage for the motor windings, 115 volts is fed directly to servo motor B1001 and through the contacts of K604 to servo motor B1101. During homing (fig. 44), the motor disabling relay is energized, and excitation voltage is removed from B1101. 115 volts is also applied to servo motor V201 through pin 12 of P201.

b. The 115 volts is also applied to transformer T901 through the RC combination of R929 and C924, which provides a 25° phase shift in the voltage. Compensation for phase shift in the initial voltage due to circuit components is provided by C922, C921, and C923. Transformer T901 re-

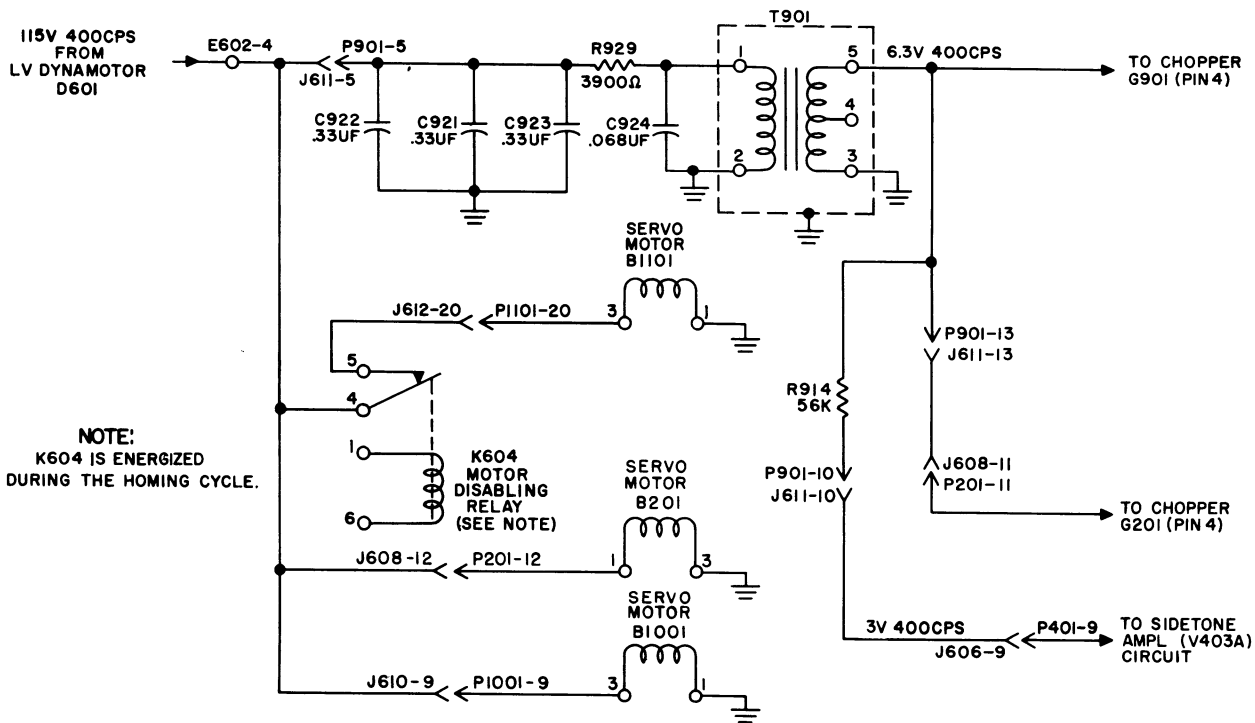

Figure 62. 115-volt, 400-cps distribution, functional diagram.

TM 806-58

duces the 115-volt input to 6.3 volts, which is used as exciting voltage for choppers G901 and G201. The output of T901 is also fed through voltage-dropping resistor R914 to provide 3 volts at 400 cps to sidetone amplifier V403A.

90. Distribution, +250-Volt (fig. 63)

Figure 63. +250-volt distribution, function diagram.
(See attached envelope)

Plate and screen voltages for the tubes of Radio Transmitter T-195/GRC-19 are generally supplied from the +250-volt output of low-voltage dynamotor D601. Input voltage to D601 is supplied from a +24-volt source, as shown in figure 61. The +250-volt output of D601 is fed through the af choke to the various subchassis (fig. 63).

91. Distribution, -45-Volt

The lv dynamotor supplies -45 volts to the transmitter for use in the antenna switching and keying circuits (fig. 54). In addition, this supply is used as a bias voltage for modulator tubes V406 and V407 (fig. 40), and as a source of bias for power amplifier tubes V201 and V202 (fig. 30).

92. Distribution, +1,000-volt

High-voltage dynamotor D602 supplies +1,000 volts for use as plate and screen voltage for the power amplifier tube (fig. 30). In addition, +1,000 volts are applied to the center-tapped primary winding of the modulation transformer to provide plate voltage for V406 and V407 (fig. 40). The +24-volt input circuit of D602 is shown in figure 61.

93. Servo Motor Operation (fig. 64)

The servo motors (B201, B1001, and B1101) used in Radio Transmitter T-195/GRC-19 are two phase induction motors. Each motor has two windings; one winding receives voltage from the 115-volt, 400 cps supply, and the other receives voltage from the output circuit of its respective servo amplifier.

Note. The following discussion is general and does not refer to a particular circuit. The transmitter servo circuits, however, are all basically the same, with minor exceptions.

a. The dc error voltage from a discriminator is applied to the input circuit of a servo amplifier,

where a chopper (G201 or G901) converts the dc voltage to a square wave. Because of circuit characteristics in the amplifier, the output of the servo amplifiers will be essentially an ac voltage.

b. The exciting voltage which is applied to the coil of each chopper is obtained from the initial 115-volt, 400-cps supply, but is reduced to 6.3 volts and shifted in phase (25°) (par. 89b). The impedance of the chopper coil is such that an addi-

tional 65° phase shift is introduced. The chopper will then convert the dc voltages to a 400-cycle square wave, which will lead or lag the initial 115 volts by 90° , depending on the polarity of the dc error voltages from the discriminator.

c. As shown in A, figure 64, the current waveform A is applied to the coil of the chopper. This causes the chopper to alternately ground the dc voltage, so that a square wave is produced, such as

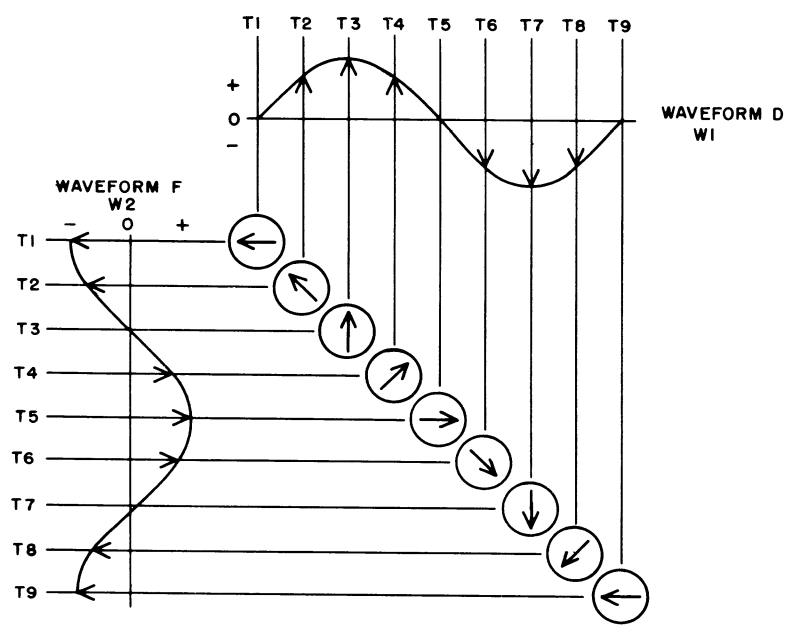
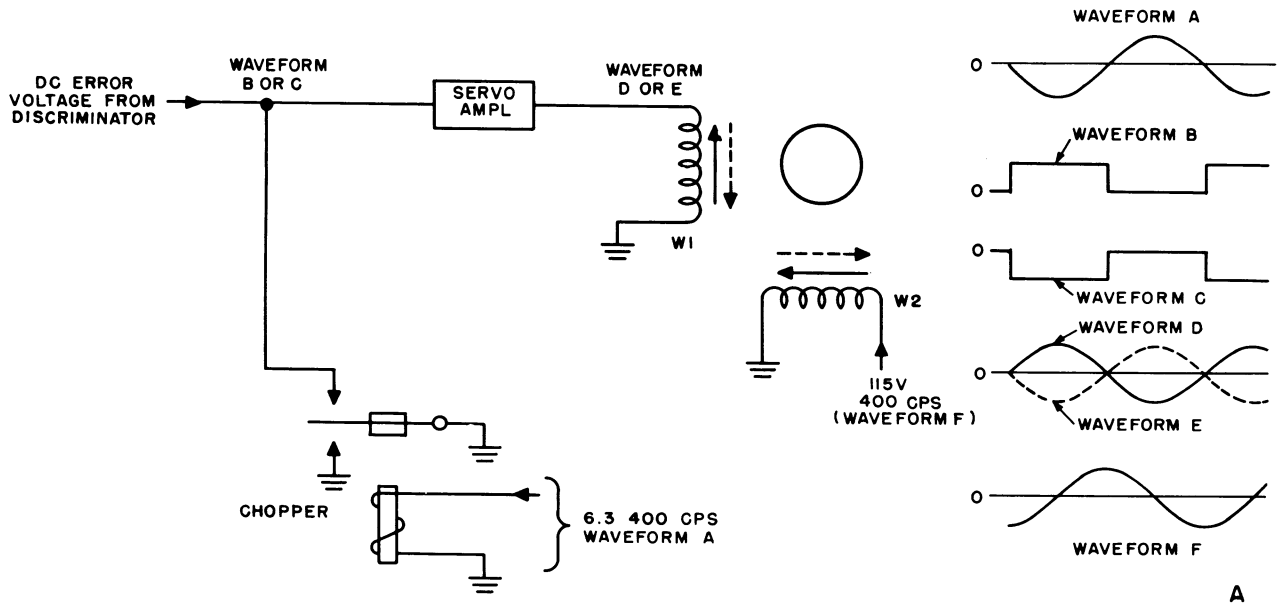

Figure 64. Servo mechanism operation.

B
TM 806-9

waveform B (if error voltage is positive) or C (if error voltage is negative). The square wave is then applied to the servo amplifying circuits, the outputs of which will appear as D (for positive square wave) or E (for negative square wave). The servo amplifier output is applied to winding W1, which is arranged so that its fields are perpendicular to those of winding W2. The current waveform F from the initial 115-volt supply is applied to W2, and leads or lags the input to W1 by 90°. This results in an effectively rotating magnetic flux being applied to the rotor of the motor.

d. Because of the currents induced in it, the rotor acts like a magnet which aligns itself with the resultant magnetic field generated by the motor windings. As the currents in the field windings vary in direction and magnitude, the resultant magnetic field effectively rotates. The rotor follows this rotating magnetic field. For this discussion, it is assumed that a positive error voltage is generated by the discriminator, and waveform D is applied to W1. Waveform D leads waveform F

(the voltage applied to W2) by 90°. Therefore, the magnetic field of W1 leads the magnetic field of W2 by 90°.

e. The direction of the magnetic field created by a positive voltage through W1 is indicated by an arrow pointing to the top of the page. A negative voltage results in a field direction indicated by the broken arrow pointing downward. In W2, the direction of the field caused by a positive voltage is indicated by the arrow pointing to the right. The broken arrow pointing to the left indicates the direction of the field caused by a negative voltage in W2. B, figure 64, illustrates the effect of combining the two fields at different times to produce a rotating magnetic field which the rotor follows.

f. If no error voltage is present, a current is not applied to W1 and a flux is induced by W2 which alternates but does not move in a rotary direction. The motor will not rotate under this condition. If a negative voltage is generated by the discriminator, the magnetic field and the rotor will rotate in a counterclockwise direction.

CHAPTER 7

FIELD MAINTENANCE

Note. This chapter contains information for field maintenance. The amount of repair that can be performed by units having field maintenance responsibility is limited only by the tools and test equipment available and by the skill of the repairman.

Section I. TROUBLESHOOTING AT FIELD MAINTENANCE LEVEL

Warning: When servicing the transmitter, avoid contact with the power supply and plate circuits. The high voltages present in these circuits can cause serious injury or death.

94. Troubleshooting Procedure

a. General. The first procedure in servicing a defective Radio Transmitter T-195/GRC-19 is to sectionalize the fault. Sectionalization consists of tracing the fault to the functional circuit responsible for the abnormal operation of the transmitter. The second procedure, localization, means tracing the fault to the defective *circuit* on the subchassis or front panel and main frame. Finally, by voltage, resistance, and continuity measurements, the defective *part* is isolated. Some faults, such as burned-out resistors, shorted transformers, and loose connections, often can be located by sight, smell, and hearing. The majority of faults, however, must be located by *checking voltage and resistance*.

b. Detailed Procedure. The tests listed in (1) through (5) below are to be used as a guide in isolating the source of the trouble. To be effective, the procedure should be followed in the order given. Remember that the servicing procedure should cause no further damage to the transmitter. The procedure is summarized in (1) through (5) below, which contain references to paragraphs having detailed information for carrying out the tests.

- (1) *Visual inspection.* It is often possible to locate troubles within an equipment

by inspecting the condition of the wiring and parts for visible evidence of failure. This inspection (par. 100) can be carried out quickly and simply and is capable of yielding rapid results; therefore, it is the first to be applied in the troubleshooting procedure. Visual inspection avoids additional damage to the transmitter by preventing improper servicing methods.

- (2) *Checking the dc voltage circuits for shorts.* These measurements (par. 101) prevent further damage to the transmitter from possible short circuits.
- (3) *Operational test.* After it has been determined in the preceding test that a short is not present in the transmitter, an operational test (par. 102) is carried out. By using the information gained from observing the symptoms of faulty operation, it is sometimes possible to determine the exact nature of the fault.
- (4) *Troubleshooting chart.* The troubleshooting chart (par. 103) presents a systematic method for checking the transmitter by eliminating possible sources of trouble until the actual trouble is found.
- (5) *Intermittents.* In all these tests, the possibility of intermittents should not be overlooked. If present, this type of trouble may be discovered by tapping or jarring the subchassis or parts under test. It is possible that the trouble is not in the transmitter itself, but in the installa-

tion (mounting, antenna, ground, auxiliary equipment, or vehicle), or the trouble may be due to external conditions; therefore, test the installation, if possible.

95. Troubleshooting Data

Take advantage of the material supplied in this manual. It will help in the rapid location of faults. Consult the following troubleshooting data:

Fig No.	Par. No.	Description
12		Radio Transmitter T-195/GRC-19, filament circuit block diagram.
	39	Radio Transmitter T-195/GRC-19, tube location.
65		Fabrication of test cables.
	105	Dc resistances of transformers, coils, and motors.
	106	Dc resistances of receptacles and connectors.
67 through 96.		Views of transmitter subchassis, showing locations of parts.
97 through 103.		Views of main frame showing location of parts.
104 and 105.		Tube-socket voltage and resistance diagrams.
106 through 111.		Terminal board voltage and resistance readings.
129		Master oscillator subchassis, schematic diagram.
130		Exciter subchassis, schematic diagram.
131		Power amplifier subchassis, schematic diagram.
132		Modulator subchassis, schematic diagram.
133		Discriminator subchassis, schematic diagram.
134		Antenna network servo amplifier subchassis, schematic diagram.
135		Antenna tuning capacitor subchassis, schematic diagram.
136		Variable inductor subchassis, schematic diagram.
137		Main frame, schematic diagram.
138		Subchassis interconnection cabling diagram.
139		Radio Transmitter T-195/GRC-19, schematic diagram.

96. Test Equipment and Tools Required

a. The test equipment required for troubleshooting Radio Transmitter T-195/GRC-19 is listed below. The technical manuals associated with the test equipment are also listed.

Test equipment	Technical manual
Electron Tube Test Set TV-7/U, or equal	TM 11-5083
Audio Oscillator TS-382/U, or equal	TM 11-2684
Electronic Multimeter TS-505/U, or equal.	TM 11-5511
Multimeter TS-352/U, or equal	TM 11-5527
Oscilloscope OS-8A/U	TM 11-1214

b. The tools and materials contained in Tool Equipment TE-113 are required for field maintenance of Radio Transmitter T-195/GRC-19.

97. Bench Testing

a. When a cause of equipment failure has been sectionalized to a subchassis, a bench test of the faulty subchassis may be required to locate the trouble through voltage readings. The undersides of the subchassis are not accessible for troubleshooting when the subchassis are mounted in the transmitter, therefore it may be necessary to remove the subchassis under test and connect it to the transmitter circuits by the use of extension cables. Directions for the fabrication of the extension cables are given in figure 65. The type of extension needed can be determined from the chart in *b* below.

b. To prepare a subchassis for bench testing, remove the subchassis from the transmitter according to the instructions contained in paragraph 108. *Be careful to avoid the possibility of disturbing the synchronization of the gear train with the master-oscillator subchassis, exciter subchassis, and power-amplifier subchassis.* Connect the extension cables between the transmitter and subchassis according to the chart below.

Caution: When the subchassis are operated outside the transmitter, dangerous voltages are exposed at the tube-socket pins and other points on the underside of the chassis. Observe the rules for servicing in the presence of high voltage to prevent possible injury.

Subchassis	Cable No.	Connect between
Master oscillator	4	P802—J617
Exciter	2	P101—J607
Power amplifier	2	P201—J608
Discriminator	4	P302—J609
Antenna tuning capacitor	1	P1001—J610
Variable inductor	3	P1101—J612
Modulator	3	P401—J606
Antenna-network servo-amplifier	2	P901—J611

98. General Precautions

When a transmitter is to be serviced, observe the following precautions very carefully:

a. When the transmitter is removed from the case, cabinet, or rack for servicing, connect an adequate ground to the main frame and to any subchassis operated outside the main frame before connecting the power cord.

b. Make certain that the transmitter is disconnected from the power source or is turned off before contacting high-voltage circuits, changing connections or removing fuses.

c. After disconnecting tuning shafts for removal of a subchassis, avoid turning the shafts or tuning controls unless necessary for troubleshooting or adjustment. Careful handling may eliminate the need for synchronization. It will be helpful to make a note of the positions of the front-panel controls because a control may be disturbed during servicing.

d. Careless replacement of parts often makes new faults inevitable. Note the following points:

- (1) Before unsoldering a part, note the position of the leads. If the part has a number of connections, tag each lead.
- (2) Be careful not to damage other leads while pulling or pushing them out of the way.
- (3) Do not allow drops of solder to fall into the transmitter. They may cause short circuits.
- (4) A carelessly soldered connection may create a new fault. It is very important to make well-soldered joints. A poorly soldered joint is one of the most difficult faults to find.
- (5) When a part is replaced in the rf circuit, it must be placed in the exact position of the original part. A part that has the same electrical value but different physical size may cause trouble in high frequency circuits. Give particular attention to proper grounding when replacing a part. Use the same ground as in the original wiring. Failure to observe these precautions may result in oscillation of the circuit or other erratic symptoms.

e. Before taking voltage measurements or performing circuit alignments, always check the value

of the input dc voltage source. The input dc voltage should be approximately 28.5 volts.

99. Troubleshooting Notes

a. To avoid the necessity for removing a subchassis when voltage is to be measured at a tube-socket pin, remove the tube, insert a short length of thin insulated wire having both ends bared into the desired contact, and replace the tube. Connection to the test equipment then can be made through the exposed end of the wire.

b. Before attempting to do any kind of work on the circuits, be sure that all power to the transmitter has been turned off and that no danger from charged capacitors in the high-voltage circuits exists. Use a grounding stick, such as a metallic rod having an insulated handle, for shorting circuits to ground. The rod of the grounding stick should be attached to a copper-braid strap with a strong alligator clip to ensure good ground contact.

c. Before attempting to turn on the transmitter for troubleshooting, alignment, or test purposes, be sure that no violation of security or frequency assignments will occur. A dummy antenna such as shown in figure 66 will prevent rf radiation. The dummy antenna uses a 150-watt incandescent lamp in a porcelain-type screw receptacle. The lamp is connected in series with an 80- μmf capacitor which is rated at 15 kilovolts, dc. The dummy antenna is connected between the WHIP ANTENNA receptacle (fig. 9) and ground.

100. Visual Inspection

When a transmitter is brought in from the field for checking or repair, remove its case and inspect it as follows, observing the warning given in paragraph 38.

a. Inspect all cables, plugs, and receptacles. *Check to see that all connectors are seated properly.* This is important, because improperly seated connectors are a frequent cause of abnormal operation in equipment. Repair or replace any connectors or cables that are broken or otherwise defective.

b. Inspect for burned insulation and for resistors that show signs of overheating. Look for wax leakage and for any discoloration.

c. Inspect for broken connections to tube sockets, plugs, and other apparatus, as well as for defective soldered connections. Look for bare wires touching the chassis or adjoining wires.

1. THE MULTI-CONDUCTOR EXTENSION CABLES ARE TO BE FABRICATED OF NO. 18 TO 22 GAUGE STRANDED WIRE. INSULATION MUST BE RATED AT 600V.
2. CONNECTORS SHOWN VIEWED FROM REAR.
3. CABLES TO BE LACED WITH NO.6 VINYLITE LACING CORD AS SHOWN IN INSERT.
4. MAXIMUM LENGTH OF ALL CABLES IS 24 IN.
5. CHECK CONTINUITY AFTER COMPLETING FABRICATION.
6. LABEL EXTENSION CABLES FOR IDENTIFICATION.

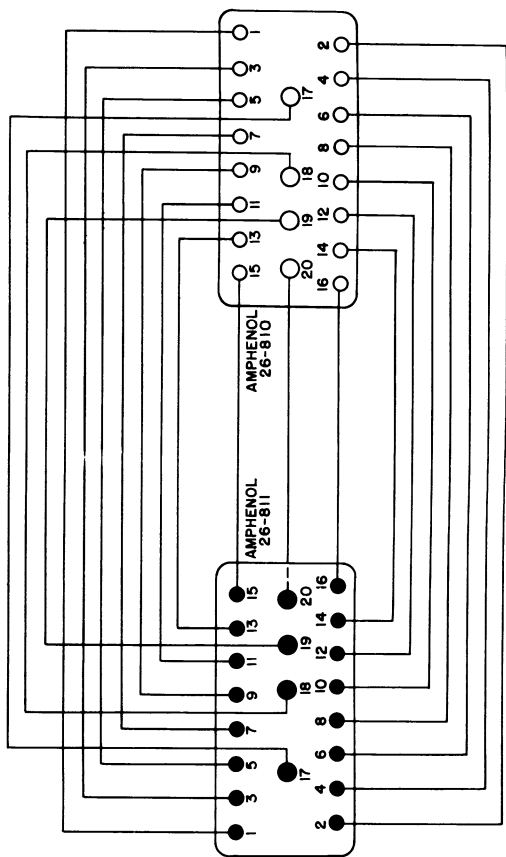
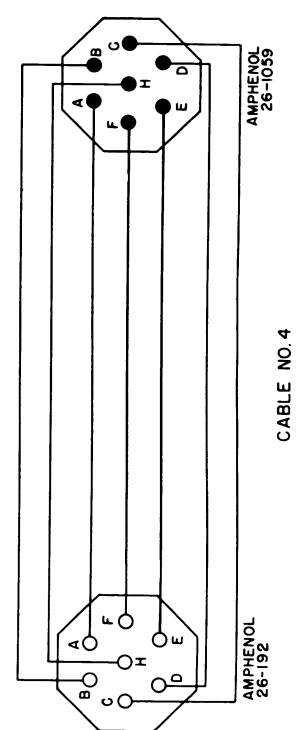
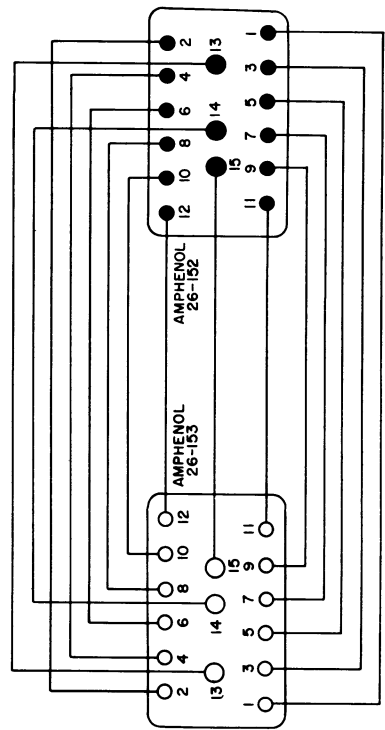
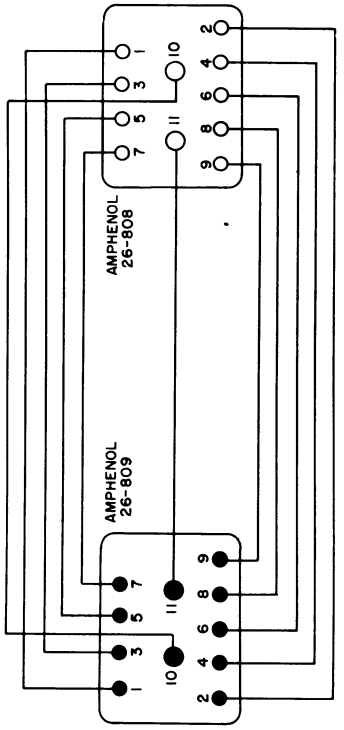
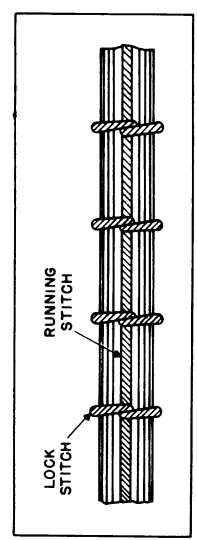

Figure 65. Fabrication of test cables.

d. Make certain that all tubes are in their correct sockets. Inspect for loose tube pins. Replace defective tubes.

e. Inspect fuses for correct rating and type. Check carefully for short circuits (par. 101) whenever a blown fuse is found.

f. Operate the tuning mechanism both manually and with the Autotune system. See that the BAND SELECTOR and TUNING CONTROL knobs turn freely. Rough operation or binding indicates a damaged tuning system or need for cleaning and lubrication (par. 110).

g. Check all switches and controls for ease of operation.

101. Checking Key Circuits for Shorts

The dc circuits of the transmitter are protected by three fuses (F601, F602, and F603). A short in the dc circuits usually will cause one of the three fuses to blow out. The three tables below give short-locating procedures for each fused circuit. When checking for shorts, use the table which corresponds to the blown fuse.

a. General.

- (1) Use a 20,000 ohms-per-volt meter for making resistance measurements. Calibrate the meter carefully; readings should not vary more than 10 percent from the readings given in the charts.
- (2) Measurements are made between the check point and ground, unless otherwise stated.
- (3) Return the equipment to its original condition after each check. In the *Additional checks* column, return the equipment to the condition stated in the first column.
- (4) If an abnormal reading is obtained, and the parts listed under *probable trouble* are not defective, consult the schematic diagrams to locate the trouble in the circuit in which the abnormal reading was obtained.

b. *Preparatory Procedures.* Make the following preparations before checking.

- (1) Remove all external connections from the transmitter.
- (2) Remove the transmitter from its case.
- (3) Calibrate the test meter carefully, by means of the *zero adjust* control.

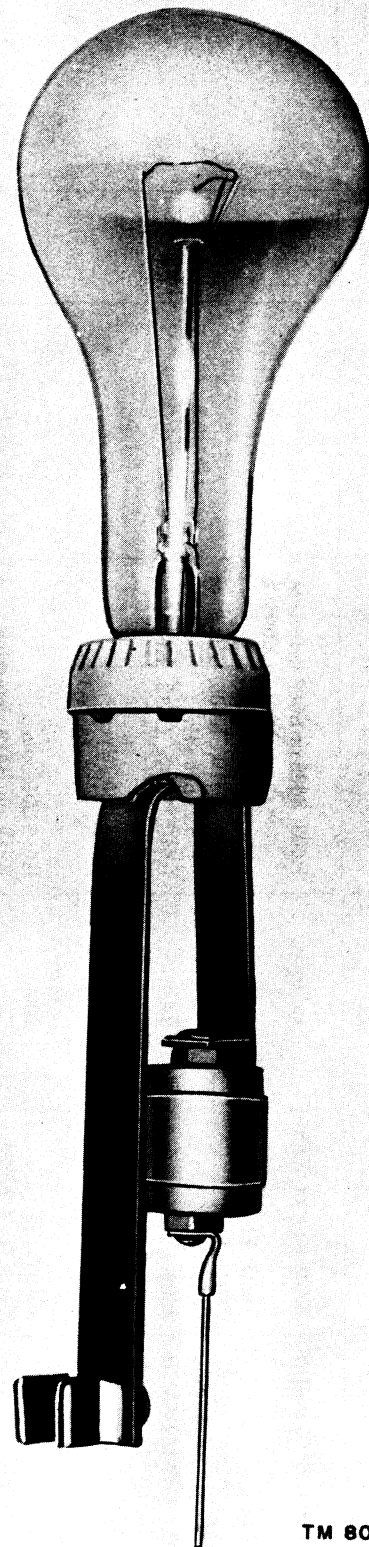

TM 806-104

Figure 66. Dummy antenna.

c. Checks for F601 (fig. 61).

Equipment conditions	Check point	Normal resistance (in ohms)	Probable trouble	Additional checks	Normal resistance (in ohms)	Probable trouble
F601 removed. S606 to OFF.	X'mtr side of XF601.	Infinity	K608, S606 or S608 defective. Line short, F601 to K608-2.			
Any condition	Term. F1 of B601	2	B601 defective.			
Disconnect P201, P101, P1001, P401, P802; S606 to OFF. DIAL DIM to OFF. TEST METER to PA GRID.	J607-11	0.5	B602, S610, K605, K607 or C622 defective.			
	J608-18	2.1	K616, K613, C632, K610, or C658.			
	J607-1, 2, 3, and 4	200 at one or more term.	K613 defective.			
	J610-3	200	K616 defective.			
	Term. 1 of K610	55	K610 or R619 defective.			
	J617-C	55	R611 defective.			
	P802-C	6	Short in mo filament circuit.			
	P201-13	14	B202, C249, C209, C210 or S202 defective.			
	Connect between P201-13 and P201-1.	280	K203 defective.	P201-13. Connect P101.	13	K201 defective.
	P101-14	58	Short in exciter filament circuit.	Note. If BAND indicator reads in 6 to 20 mc range, disconnect P101 and read resistance between P201-6 and P201-13 to check K201. Resistance should be 700 ohms.		
	P401-14	400	K403 or K402 defective.			
	J601-F	Infinity	S603, S606, Z601 or K605 defective.			
	Connect between P401-18 and P401-20.	26, 26	Short in modulator filament circuit. (V401, V402, V403, V404, V406 or V407.)			
	J606-8	Infinity	B603 short to ground	S606 to CALIB. S606 to CW	250 100	K602 defective. C644 or K603 defective.
Disconnect P401. Close cabinet interlock S611. S606 to OFF.	Connect test leads between J606-8 and junction of R605 and B603.	4	R605 or B603 defective.			

Disconnect P1101. SERVICE SELECTOR S606 to CW.	J612-11	200	K617 defective. B1102 or R1101 defective.		
	Connect test leads between P1101-14 and P1101-15.	15			
	P1101-15	Infinity			

Note. If F601 blows during homing cycle, check K604.

d. Checks for F602 (figs. 61 and 129).

Equipment conditions	Check point	Normal resistance (in ohms)	Probable trouble	Additional checks	Normal resistance (in ohms)	Probable trouble
Remove F602. Disconnect P901, P1101, P1001, and P201.	E602-1	0.3*	D601 is defective. D601 is defective. B1101 is defective. B1001 is defective. B201 is defective. Defect in T901 primary circuit (fig. 62). D601 is defective. R119 defective.			
	J611-5	12				
	Connect between P1101-20 and P1101-18.	160				
	P1001-9	160				
	P201-12	160				
	P901-5	4.4K				
Disconnect P101	J607-6	55	D601 is defective. R119 defective.			
	Connect test leads between P101-6 and P101-5.	150K				
Disconnect P101, P201, P401, P901 and P802.	J606-11	90	D601 defective. R626 defective. C908, C918 defective. B1101 defective. B1001 defective. C409, R409, R415 or R414 defective. C405 defective. C810 defective. C146, C135, C128 or C143 defective. C243, C244, R204 or B201 defective.			
	Connect test leads between J606-7 and J606-11.	50K				
	P901-11	Infinity				
	J611-8	250				
	J611-7	250				
	V401-6 (pull tube)	150K				
	P401-11	Infinity				
	P802-A	Infinity				
	P101-13	370K+				
	P201-9	1.1 meg				

*Resistance varies with the position of the dynamotor armature.

c. Checks for F603 (figs. 30, 40, 54 and 61).

Equipment conditions	Check point	Normal resistance (in ohms)	Probable trouble	Additional checks	Normal resistance (in ohms)	Probable trouble
Remove F603. Disconnect P205, P206, and P201.	E603-1 P205	0.3 Infinity	D602 defective. C203, C202, C250, or C251 defective.			
	J618-B Connect between P201-5 and P205.	180* Infinity	D602 or C659 defective. C204 defective.			

*Resistance varies with the position of the dynamotor armature.

102. Operational Test

Operate the equipment as described in the equipment performance checklist (par. 41). This checklist is important because it frequently aids in sectionalizing the trouble without the need for further testing. Check for overheated parts, faulty controls, and intermittent operation. Observe closely the readings of the test and audio level meters.

103. Troubleshooting Chart

The following chart is supplied as an aid in locating trouble in the radio transmitter. It lists the symptoms that the repairman observes, either visually or audibly. The chart also indicates how to localize trouble quickly to the defective stage, and to defective parts within the Autotune and/or automatic tuning system. When the trouble has been localized to a stage or circuit, a tube check, and voltage and resistance measurements of that stage or circuit, should be sufficient to isolate the defective part.

Symptom	Probable cause	Correction
1. Neither blower starts when switching SERVICE SELECTOR switch from OFF to VOICE/FSK.	Filament fuse F601 is defective-----	Replace F601. If replacement fuse burns out, check for a short circuit in the 24-volt line which supplies the transmitter filaments, dial lights, blowers, Autotune motor, etc. Refer to figure 61.
	Power cable is defective or has not been properly installed.	Check continuity of power cable. Determine that the power cable plug has been seated adequately to the front panel power receptacle. Check connections of power cable to power source.
	Defective blowers-----	Check B602 and B202 for proper operation.
	Variable inductor plug, P1101, not fully inserted into chassis receptacle, or the interlock connection between pins 3 and 13 of P1101 is open.	Check continuity between pins 3 and 13 of P1101. Fully insert plug into chassis receptacle.
	Antenna tuning capacitor plug P1001 is not fully inserted into chassis receptacle, or the interlock connection between pins 5 and 7 of P1001 is open.	Check continuity between pin 5 P1001 and ground. Fully insert plug into chassis receptacle.
	Power amplifier plug P201 is not fully inserted into chassis receptacle or the interlock connection between pin 14 of P201 and ground through S202 is open.	Check continuity between pin 14 of P201 and ground, check S202, and fully insert the plug into the receptacle.
2. Test meter does not indicate normal on LINE VOLTAGE scale.	Defective filament start relay (K608) ..	Check relay; replace if defective.
	Power source voltage is defective-----	Check supply voltage with another meter. If proper indication is obtained, replace the front panel test meter.
	High-resistance connections between power source and transmitter.	Clean and tighten connections.
3. Low-voltage dynamotor does not start within two minutes after SERVICE SELECTOR switch has been turned from OFF to CALIB.	R618 or R614 defective-----	Check resistors, and replace if necessary.
	F602 defective-----	Replace F602. If replacement fuse burns out, check for a short circuit in the 24-volt input circuits of the dynamotor, D601 in accordance with paragraph 101.
	Cabinet interlock S611 is defective or not closed.	Check continuity of S611. Check panel-to-case fit by means of 16 screws at edges of front panel.

Symptom	Probable cause	Correction
3. Low-voltage dynamotor does not start within two minutes after SERVICE SELECTOR switch has been turned from OFF to CALIB—Continued.	K602 is not energized due to defective time delay relay.	Check K602 and K403, and if necessary, replace. Determine that the modulator plug, P401, is secure. Check continuity of connections from P401 to K403 contacts and heater coil.
4. Autotune does not operate when changing channels.	Autotune motor B601 defective ----- The common clip of S604 front (PRESET CHANNELS switch) is not connected to ground when the SERVICE SELECTOR switch is in any position other than OFF due to a broken wire or dirty contacts of the SERVICE SELECTOR switch. Defective Autotune relay K610-----	Check and replace if defective. Check and repair or clean, as necessary. Check; replace if defective.
5. BAND SELECTOR and TUNING CONTROL knobs keep reversing after PRESET CHANNELS switch is moved to new position.	Autotune relay K610 energized on all channels due to constant ground at term. 1.	Check open-circuit seeking switches S605 and S604; check S617 and K610.
6. BAND SELECTOR and TUNING CONTROL knobs are left unlocked at conclusion of Autotune cycle.	Autotune heads are out of synchronization.	Refer to paragraph 114.
7. Autotune positions on some channels, but does not complete cycle on all channels.	Channel-indicating dial hub not properly positioned on the Autotune control head shaft, resulting in momentary grounding of portions of S605, which is mounted to the rear of the hub on the same shaft. Autotune system is not properly synchronized.	Loosen setscrew which tightens channel-indicating dial hub to Autotune control head shaft and reposition dial hub slightly forward. Synchronise Autotune system as outlined in paragraph 114.
8. Antenna output capacitor switch, S612, rotates but does not position correctly to correspond with the setting of the BAND SELECTOR.	Exciter band switch not correctly synchronized with the BAND SELECTOR. Defective wiring between S101C and C614A. Contacts on switches bent or dirty.	Refer to paragraph 116. Check and repair. Clean or adjust switches if necessary.
9. Antenna output capacitor switch S612 does not rotate, regardless of the position of the BAND SELECTOR.	P101 not securely connected to J607--- K613 does not operate----- Defective brushes on motor B603 or defective motor. Defective +24-volt supply to motor B603. Ground connection to B603 through K613 and S606A defective.	Check and secure properly. Check the energizing circuit of K613. This circuit consists essentially of K613, S614A, and S101C. Check and repair or replace. Check K609 and replace if defective.
10. Antenna tuning capacitor and variable inductor fail to accomplish their homing cycle.	Pin 4 of power amplifier plug P201 not momentarily grounded between bands of BAND SELECTOR.	Check K613 and replace if defective. Check ground path through S606B. Check continuity between pin 4 of P201 and ground while rotating the BAND SELECTOR and determine that this pin is momentarily grounded <i>between</i> bands. If not, check the synchronization of power-amplifier band switch shaft with the BAND SELECTOR. Check operation of the cam-driven contacts which connect to pin 4 of P201 and ground.

Symptom	Probable cause	Correction
11. The dc motor (B1102) operates the variable inductor, but the homing cycle is never completed. That is, the ribbon continues to wind and unwind from the ceramic coil form.	<p>The variable capacitors on the antenna tuning capacitor are not at minimum capacitance. This usually is caused by lack of synchronization between the linear switch, S1002, and the variable capacitor.</p> <p>Continuous short circuit between pin 4 of power-amplifier plug P201 and ground regardless of the position of the BAND SELECTOR. This pin should be grounded only between bands on the BAND SELECTOR.</p> <p>K616 remains energized due to the fact that spring contact 3 of S1003 remains grounded even though linear switch S1002 is in its lowest detent position.</p> <p>K616 remains energized due to the fact that pin 6 of variable inductor plug P1101 never finds an open circuit to ground regardless of the position of S1101B front.</p> <p>No dc voltage at pin 1 of the antenna-network servo amplifier plug, P901, when the antenna tuning capacitor should perform its homing cycle.</p> <p>Antenna-network servo amplifier plug P901 not properly inserted.</p> <p>Open circuit between pin 5 of V902 and terminal 4 of B1001.</p> <p>Defective antenna-network servo amplifier due to failure of V901, V902, or G901.</p> <p>Defective servo motor B1001</p> <p>Antenna tuning capacitor plug P1001 not completely inserted.</p>	<p>Synchronize linear switch S1002 with the variable capacitors by rotating the gear of B1001 with a finger until S1002 moves in a direction away from minimum capacitance.</p> <p>Check synchronization between power-amplifier band switch shaft and BAND SELECTOR. Check operation of cam-driven contacts which connect to pin 4 of P201 and ground.</p> <p>Adjust the position of S1003 so that when linear switch S1002 is in its position for minimum capacitance, it operates the switch, thereby removing the ground from spring contact 3 of S1003.</p> <p>Check to determine whether all circuits between S1101B front and S101E front are connected as they should be, and that no inadvertent ground of pin 6 of P1101 exists.</p> <p>The operation of K616 should apply a dc potential through R620 to pin 1 of the antenna-network servo amplifier. Check to determine whether these component parts and circuits are performing this function.</p> <p>Check to determine whether P901 is properly inserted.</p> <p>Check continuity of circuit and repair if necessary.</p> <p>Replace the suspected antenna-network servo-amplifier subassembly with one that is known to be operative. If this is not possible, check and/or replace V901, V902, and G901.</p> <p>Replace suspected antenna tuning capacitor subunit with one that is known to be operative.</p> <p>Check to determine whether P1001 is properly inserted.</p>
12. The dc motor, B1102, does not operate to start the homing cycle of the variable inductor, regardless of the position of the transmitter BAND SELECTOR.	<p>No dc voltage is applied to dc motor B1102 in any position of the BAND SELECTOR.</p> <p>Worn brushes on dc motor B1102.</p> <p>Defective dc motor B1102</p>	<p>Check continuity of 24-volt line through relays K609, K613, K616, and K617; check operation of relays.</p> <p>Replace brushes if defective.</p> <p>Replace motor.</p>
13. The dc motor (B1102) operates the variable inductor, but the motor fails to reverse direction when the ribbon is within about three turns of being completely unwound from the ceramic coil form. This may result in breaking the ribbon when the ceramic coil form reaches inductance stop.	<p>Terminal 1 of K617 is not being grounded through S1101A (front) and S606, when approximately three turns of ribbon remain on the ceramic coil form.</p>	<p>Check S1101A front and rear to determine whether or not they are synchronized properly with respect to the number of turns remaining on the ceramic coil form. Check the grounding circuit through S1101A front and rear and S606.</p>

Symptom	Probable cause	Correction
14. The dc motor (B1102) operates the variable inductor, but the motor fails to stop before the ceramic coil is within a few turns of being completely wound. This may result in breaking the ribbon when the ceramic coil form reaches its maximum inductance stop.	Terminal 1 of K617 is not removed from ground by S1101A rear as it should be, just before the ceramic coil form reaches its maximum inductance stop.	Check S1101A rear to determine whether or not it is synchronized properly with respect to the maximum inductance stop of the ceramic coil form.
15. No indication on the test meter on any transmitter band with the TEST METER switch in the PA GRID position.	Filaments of V201 in the power amplifier not on because of failure of the tube filaments themselves, or faulty operation of the power-amplifier blower interlock, S202.	Check the filaments of V201 and replace tube, if necessary. Check to determine whether voltage is present across the pa blower, B202. If the pa blower operates intermittently, the motor brushes should be checked and replaced, if necessary.
	No rf voltage from the master oscillator present at exciter receptacle J101. The magnitude of this voltage should be approximately 5 volts, rms, with the master-oscillator output connected to J101 of the exciter.	Determine whether proper supply voltages are present at the oscillator power plug, P802. Terminal A, +150 v; terminal C, +13 v; terminal D, ground; terminal E, 24 v. If these voltages are not substantially as shown above, check, and if necessary, replace voltage regulator V601, or resistor R601.
		If supply voltages are as they should be, measure the voltage at pin 1 of V801. No negative voltage at this point indicates that the oscillator is not functioning.
		If the oscillator is functioning and no output is obtained from the master oscillator, resistance and voltage measurements should be made throughout the master oscillator sub-chassis to locate a possible component failure. If it becomes necessary to remove the oscillator from its mounting, refer to paragraph 108c. At no time should the round shield can which encloses the oscillator-frequency controlling parts be removed or loosened. Should it appear that trouble exists within the sealed portion of the oscillator, the entire master oscillator should be removed from the transmitter and replaced.
	Exciter completely out of alinement Exciter band switch shaft disengaged from BAND SELECTOR, or exciter band switch coupling clamp not tightened properly.	Refer to paragraph 118. Refer to paragraph 116.
	Exciter camshaft disengaged from the TUNING CONTROL, or cam shaft coupling clamp not tightened properly.	Adjust as required, then refer to paragraph 116.

Symptom	Probable cause	Correction
15. No indication on the test meter on any transmitter band with the TEST METER switch in the PA GRID position—Con.	V101 and/or V104 tubes or associated circuits defective.	Check and replace tubes if defective. Check voltage present between pin 8 of V104 and ground. An incorrect voltage indicates trouble at or before this point in the circuit. The presence of an rf signal at the control grid of V104 develops a negative dc voltage, the value of which is normally between -12 and -30 volts, depending on which exciter band is in use. When the BAND SELECTOR is set to the 1.5- to 6.0-mc range and the negative voltage at pin 8 of V104 is not present, the trouble is probably in the V101 stage (assuming that the master oscillator is delivering voltage to J101 of the exciter), since V102 and V103 are not used in this frequency range.
	No connection between P102 of exciter and P203 of power amplifier.	Check spring contactor E605, and clean, if necessary.
	Control grid of V201 in power amplifier (center pin of V201 socket) grounded.	Check and repair.
	Pa grid metering circuit defective (M602).	Check the following and repair or replace, if necessary: Open circuit at pin 10 of P201. TEST METER switch (S607) contacts damaged or dirty.
16. Below normal pa grid indication on the meter on all or some transmitter bands.	Pin 5 of exciter power plug P101 not grounded by keying relay K605.	Connect pin 5 of P101 to ground to determine whether this causes the test meter to indicate pa grid current. If this proves to be the case, determine whether keying relay K605 is energized by the SERVICE SELECTOR switch in the CALIB position. If the relay is not energized, check R621 and replace, if necessary.
	K201 defective	Check the energizing circuit of K201. This circuit consists essentially of K201 and S101D (rear).
	Exciter not properly aligned	Refer to paragraph 118.
17. High-voltage dynamotor. D602 does not start.	Subnormal tubes in the exciter	Check V101, V102, V103, and V104. Replace, if necessary.
	F603 defective	Replace F603. If replacement fuse burns out, check for a short in the 24-volt and +1,000-volt circuits of D602.
	K603 not energized	Check voltage between term. 3 of K616 and ground. Zero volts should be obtained. If 24 volts is obtained, K616 is energized or defective. If energized refer to step 11.
	K603 defective	Check contacts of K603. Clean if necessary. Check operation of relay; replace if defective.
18. Zero indication is not obtained on the test meter when the TEST METER switch is set to the PA CATH position.	K609 defective	Check operation of K609.
	Defective clamper tube circuit in the power amplifier.	Check V202 and associated detail parts and potentials to determine source of trouble.

Symptom	Probable cause	Correction
18. Zero indication is not obtained on the test meter when the TEST METER switch is set to the PA CATH position—Continued	No fixed bias on the power amplifier. Fixed bias at pin 10 of P201 should be approximately -22 volts when the SERVICE SELECTOR switch is set to the CW position with the key open.	Check circuits from the -45-volt output to D601 to pin 10 of P201. Check C201 and replace if defective.
19. Pa cathode current not in shaded area when key or microphone switch is closed.	K605 closed.....	Check K605 circuit.
	Antenna disconnected.....	Check and repair antenna connections.
	V202 not biased to cutoff during keying.....	Check C208, K202, K615, and K605.
	Tuning system defective.....	Check components in tuning, phasing and loading discriminator circuits. Refer to steps 20, 21, and 22.
	Pa grid drive low.....	Check exciter and oscillator stages.
20. Improper operation of the power amplifier servo system.	Pa stage defective.....	Check tube and components in pa stage.
	Pa band switch not positioned properly.....	Check and synchronize band switch shaft with BAND SELECTOR.
	No connection between P204 and P301 and P304.	Check connection.
	No torque from B201 due to lack of dc error voltage from the power-amplifier discriminator.	Check at the junction of R222 and R223 to determine whether a short circuit to ground is present at this point. Check C245 and replace, if defective. Check operation of K201. This relay should be energized when the BAND SELECTOR is in the 1.5- to 6.0-mc range.
	No torque from B201 due to failure of the power-amplifier servo amplifier.	Check and replace G201, V204, or V203. Check B201.
21. The antenna tuning capacitor does not begin its tuning operation.	Torque from B201 present in only one direction.	Either CR201 or CR202 is defective. Check and replace, if necessary.
	No dc error voltage present at pin B of P302.	Check connections in the discriminator to pin B of P302 to determine whether an open circuit or short circuit exists.
	No dc error voltage present at pin 1 of P901.	Check circuits between pin B of J609 through S614B front and contacts 8 and 9 of K616, to pin 1 of P901.
	No torque from B1001.....	Check V901, V902, G901, and associated components. Check B1001.
	Torque from B1001 present in one direction only.	Check CR301 and CR203.
22. The variable inductor does not begin its tuning operation.	No dc present at pin F of P302.....	Check loading discriminator to pin F of P302.
	No dc present at pin 12 of J611.....	Check connections between pin F of J609 through S614B rear to pin 12 of P901.
	No torque from B1101.....	Check V903, V904, and associated components. Check B1101 and replace, if defective.
	Pin 2 of P901 not grounded when S1002 is at minimum capacitance position.	Check S1002 and S1003.
23. TUNING INDICATOR does not light when the variable inductor and antenna tuning capacitor have apparently completed the tuning operation.	DIAL DIM switch is in OFF position.....	Turn the DIAL DIM switch to DIM or FULL.
	Defective dial lamp in the TUNING INDICATION.	Replace lamp if defective.
	Slight residual error in tuning system.....	If sidetone is present in CW position, no correction is necessary. If no sidetone is present, check servo system.

Symptom	Probable cause	Correction
24. TUNING INDICATOR is lighted even though the transmitter has not completed its tuning cycle.	K901 not energized.....	Check CR901, CR902, and associated components.
25. No 400-cycle sidetone heard when transmitter is keyed in CW position.	Sidetone amplifier defective.....	Check V403 and associated components.
26. No indication on VU meter while attempting to operate in VOICE or VOICE/FSK positions.	Defective C420.....	Check and replace, if necessary.
	Defective meter (M603).....	Check and replace, if necessary.
	Defective coupling from modulator to meter M603.	Check resistors R439, R440, R441, R607, and capacitor C601.
27. Dial lights in the BAND SELECTOR and TUNING CONTROL indication windows not lighting in the DIM position of the DIAL DIM switch.	Defective components in modulator subchassis.	Check modulator subchassis.
	One or more dial lights burned out.....	Turn DIAL DIM switch to FULL and determine which dial light is burned out. Access to lamp is gained by removing window gasket cover.

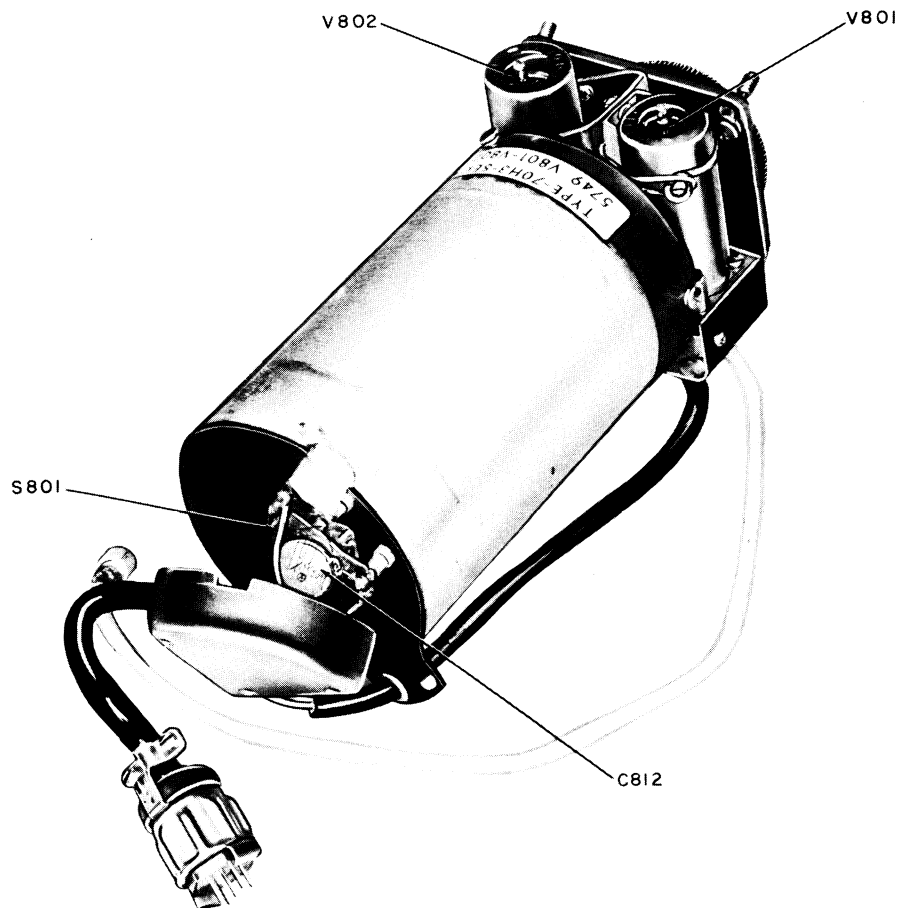

TM 806-73

Figure 67. Master-oscillator subchassis, top view.

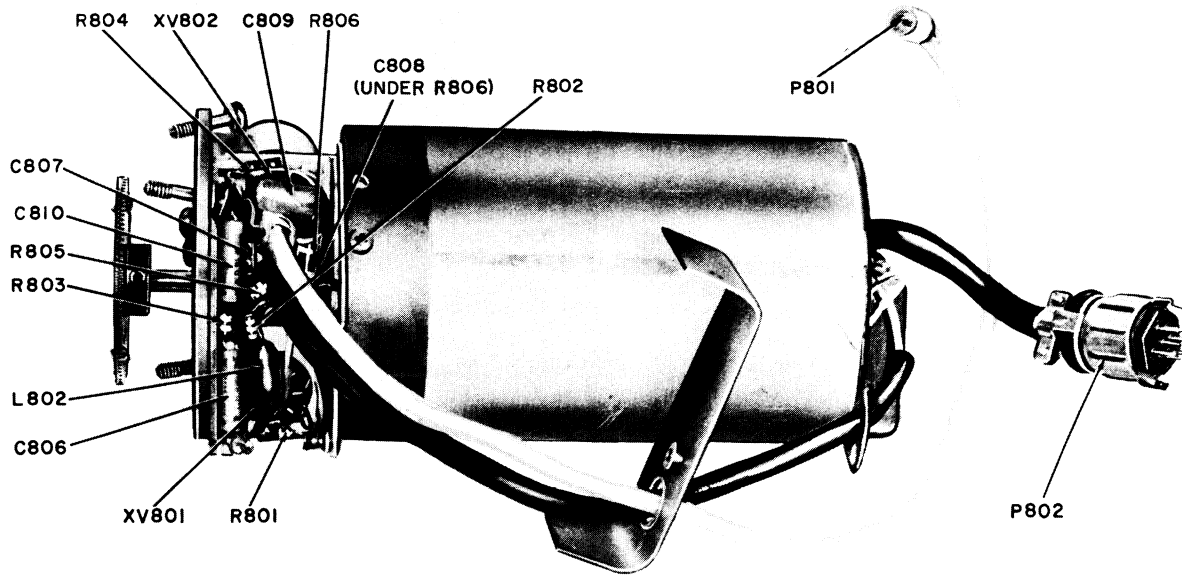

TM 806-72

Figure 68. Master-oscillator subchassis, bottom view.

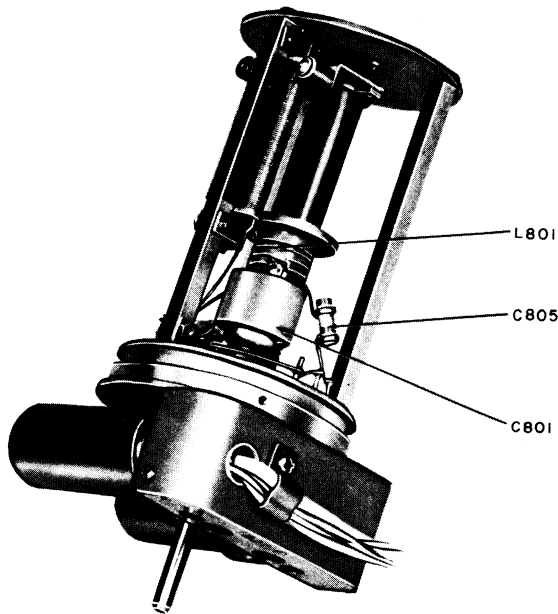

TM 806-113

Figure 69. Master-oscillator subchassis, bottom view, sealed circuit cover removal.

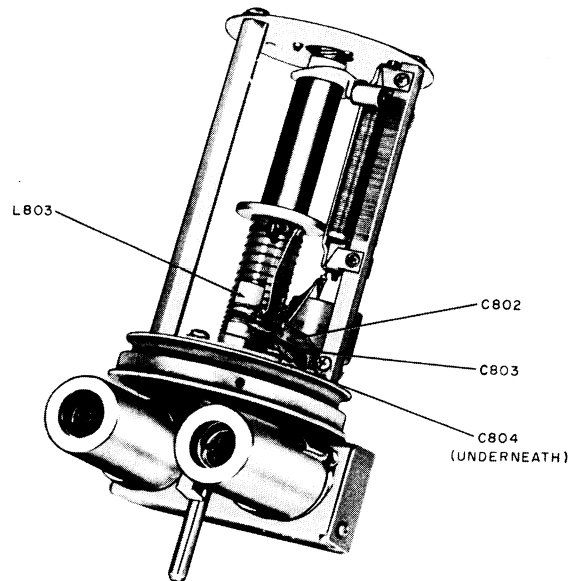

TM 806-114

Figure 70. Master-oscillator subchassis, top view, sealed circuit, cover removed.

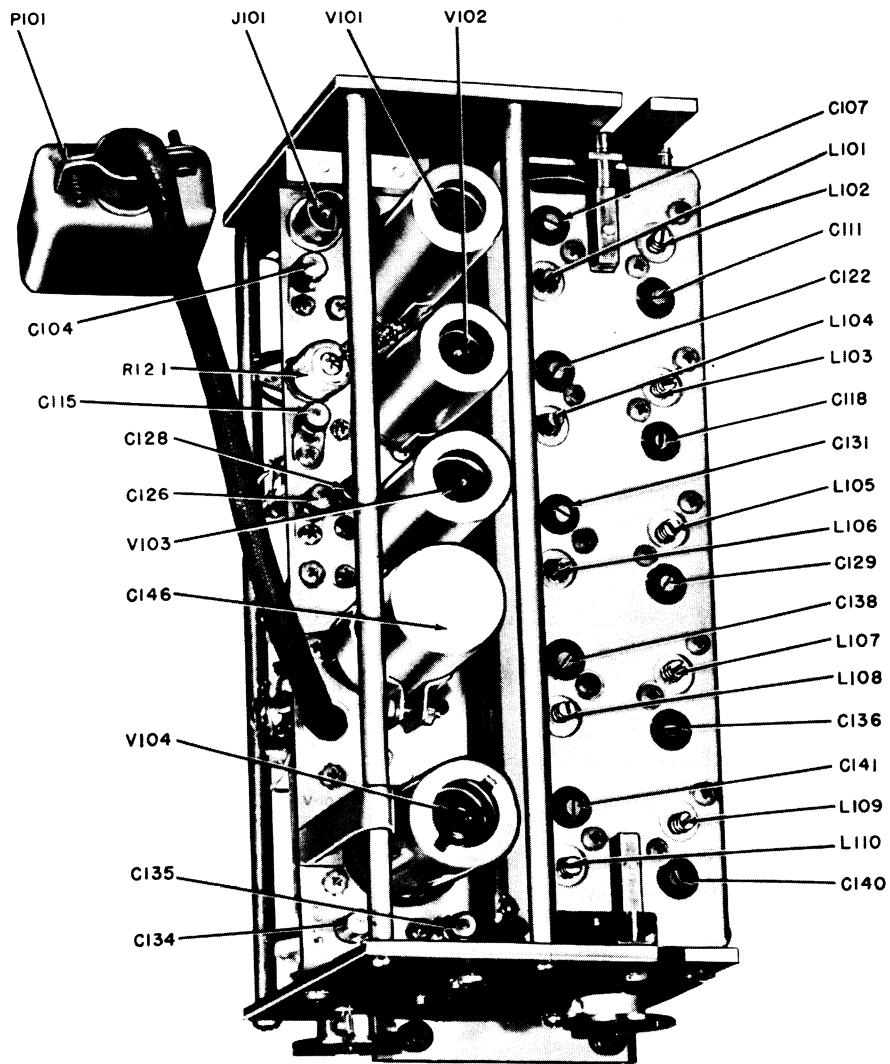

TM 806-77

Figure 71. Exciter subchassis, top view.

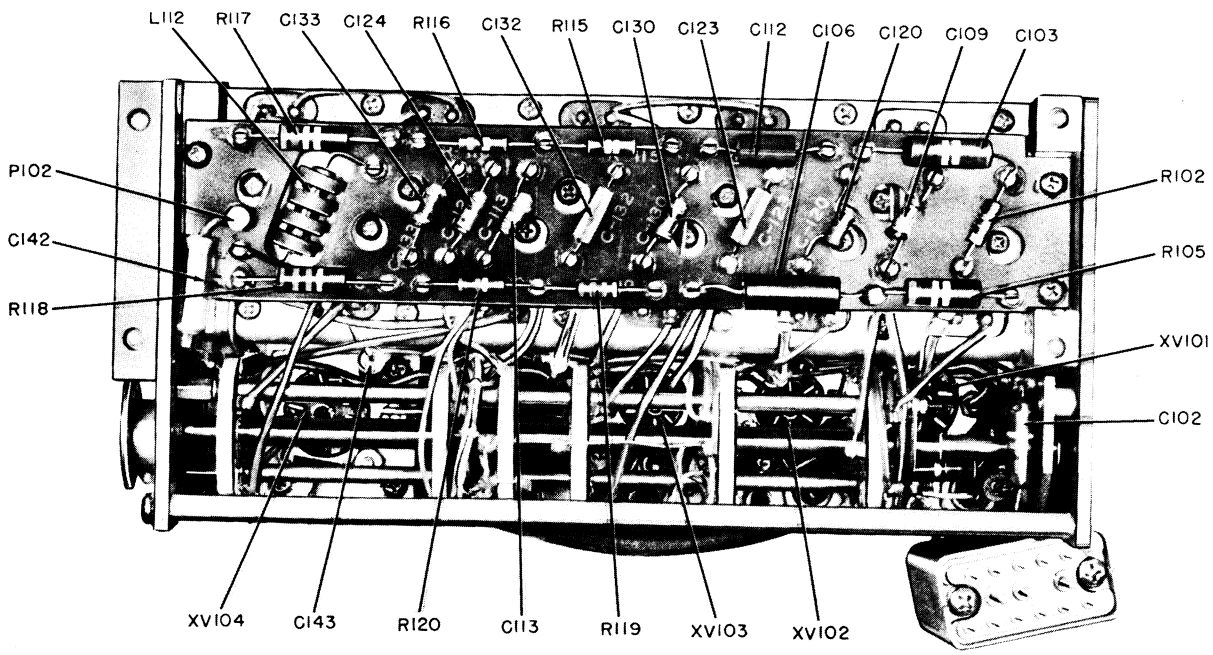

TM 806-79

Figure 72. Exciter subchassis, bottom view.

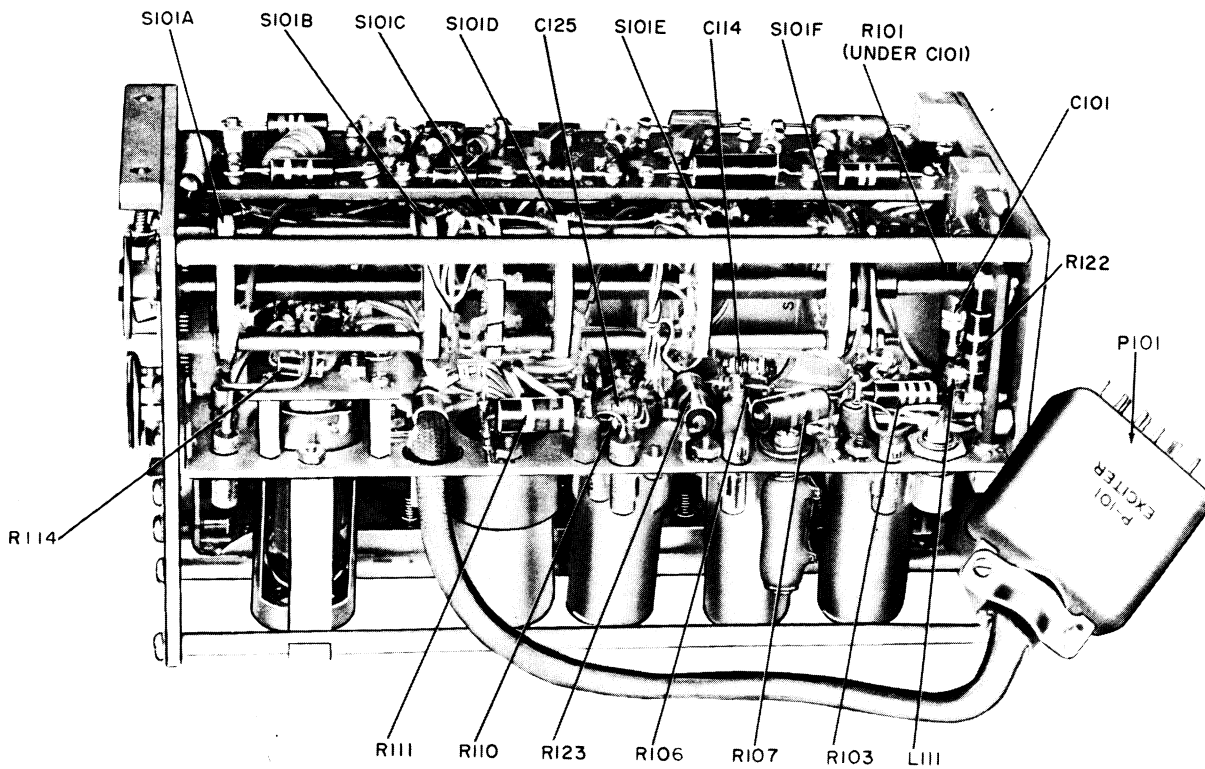

TM 806-80

Figure 73. Exciter subchassis, side view.

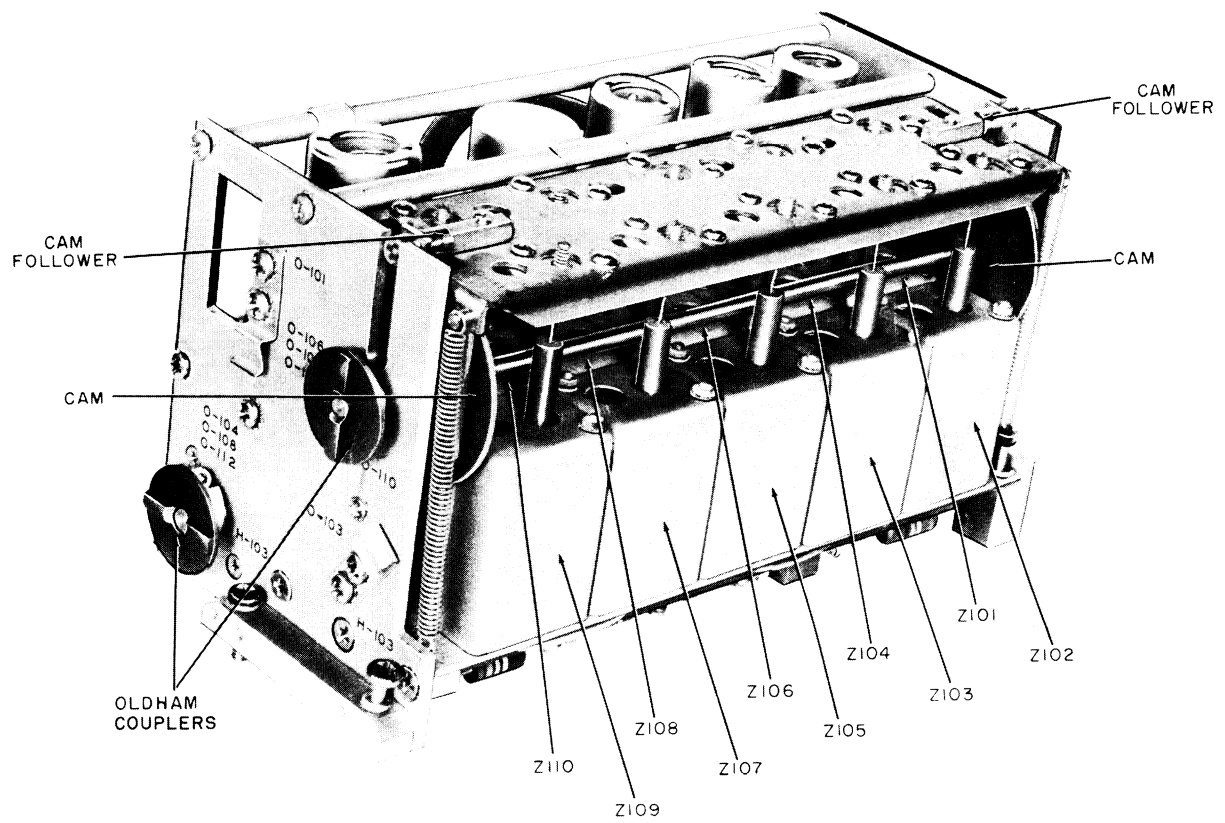
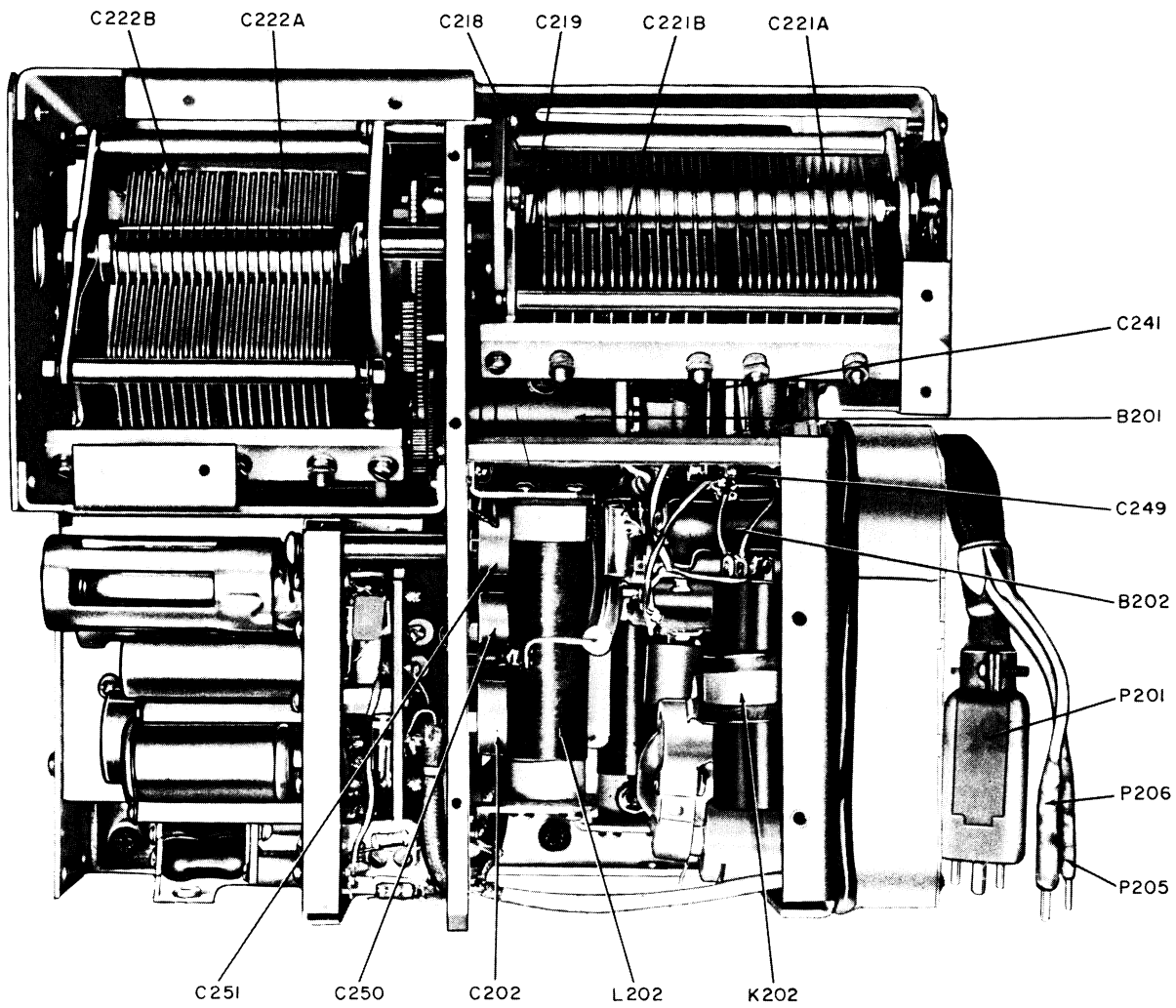

Figure 74. Exciter subchassis, front view.

TM 806-78



TM 806-83

Figure 75. Power-amplifier subchassis, top view.

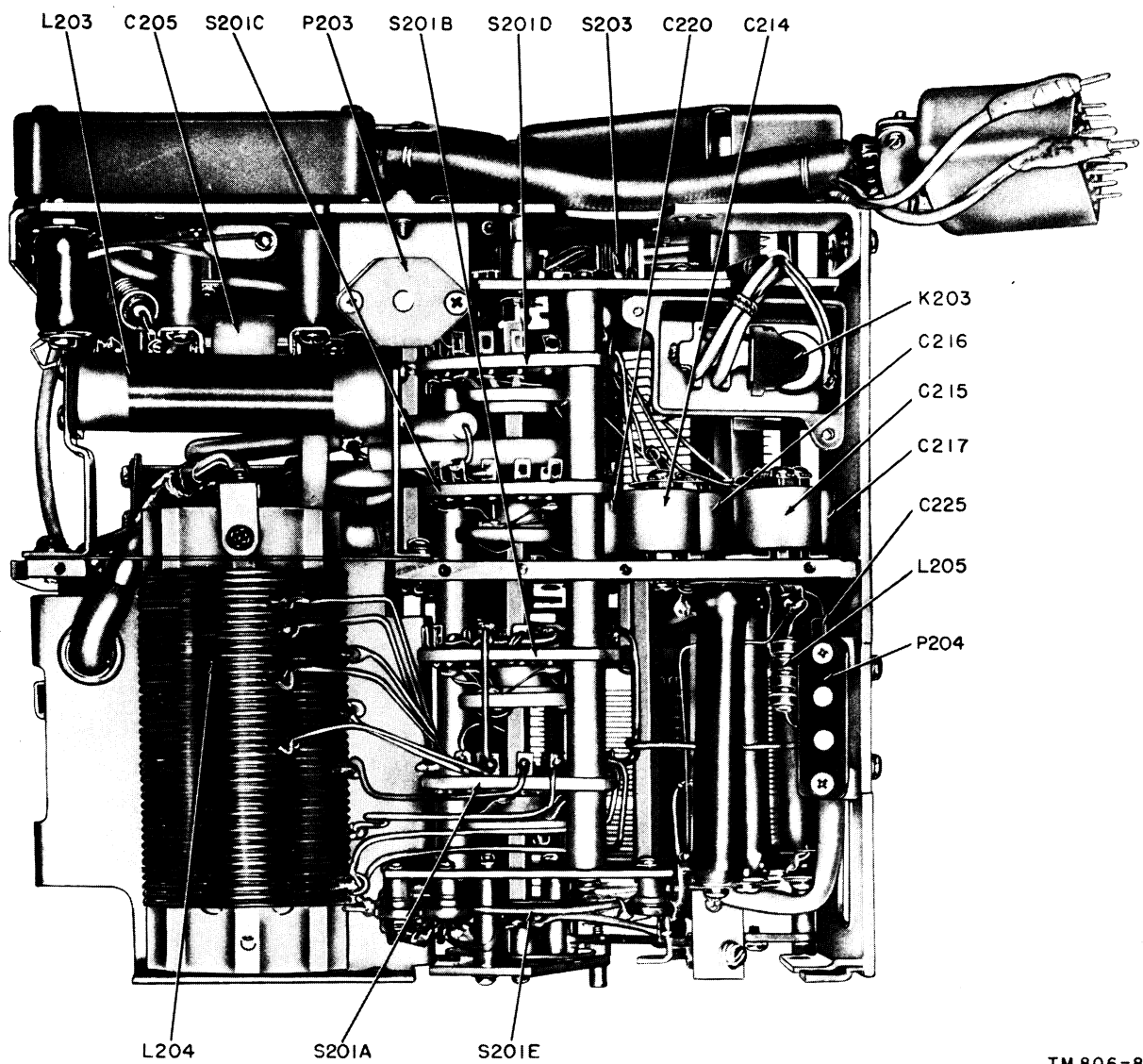

TM 806-87

Figure 76. Power-amplifier subchassis, bottom view.

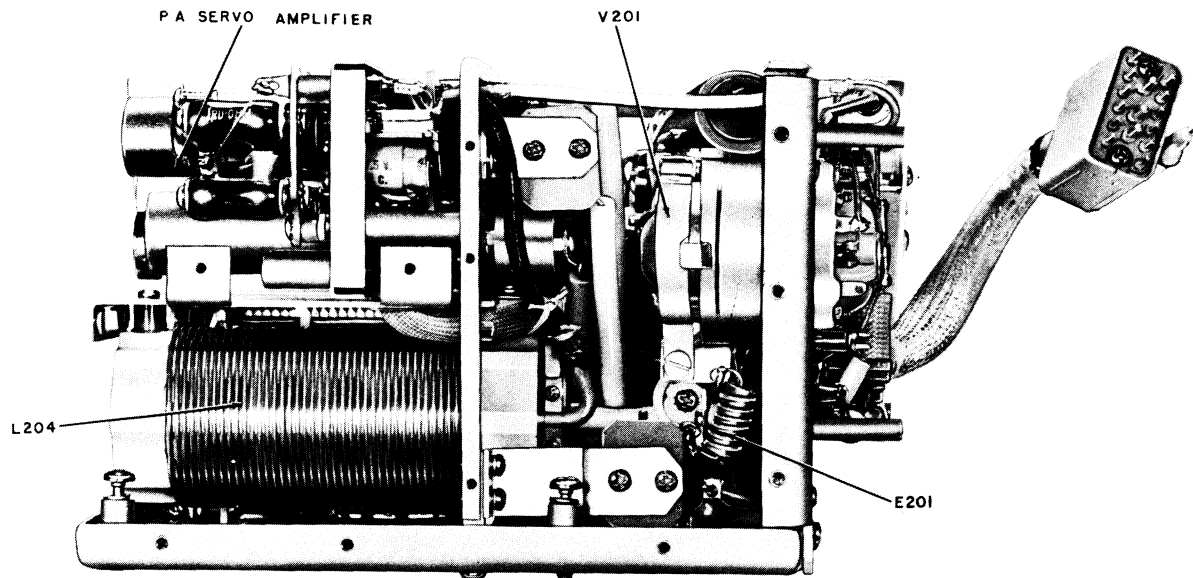

TM 806-85

Figure 77. Power-amplifier subchassis, side view.

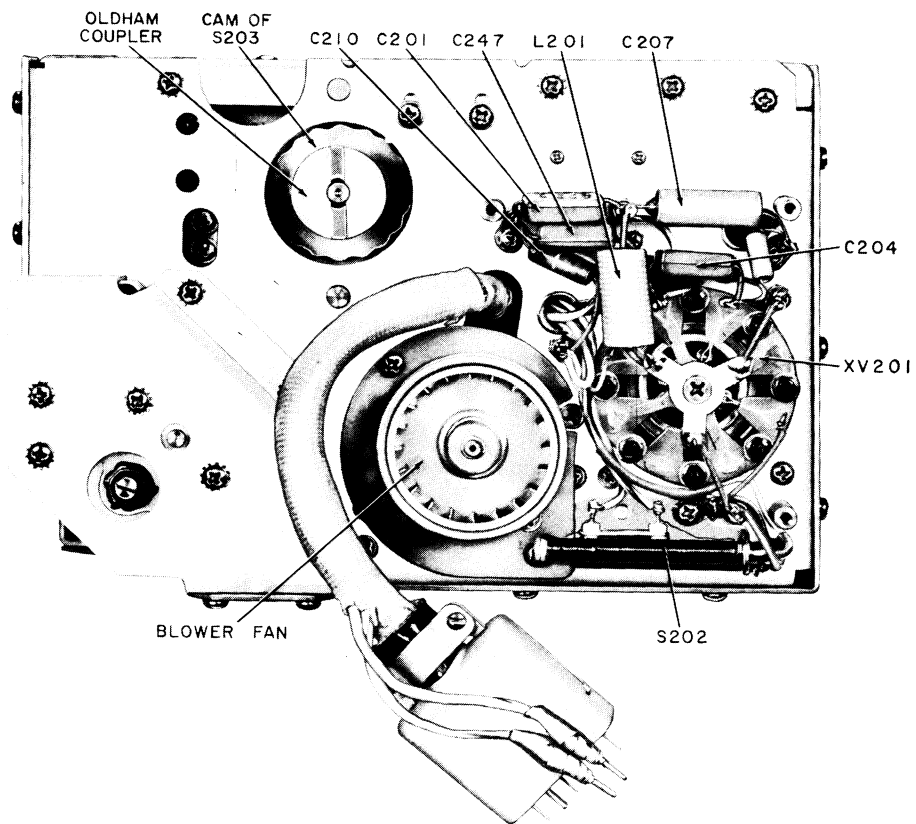

TM 806-81

Figure 78. Power-amplifier subchassis, front view.

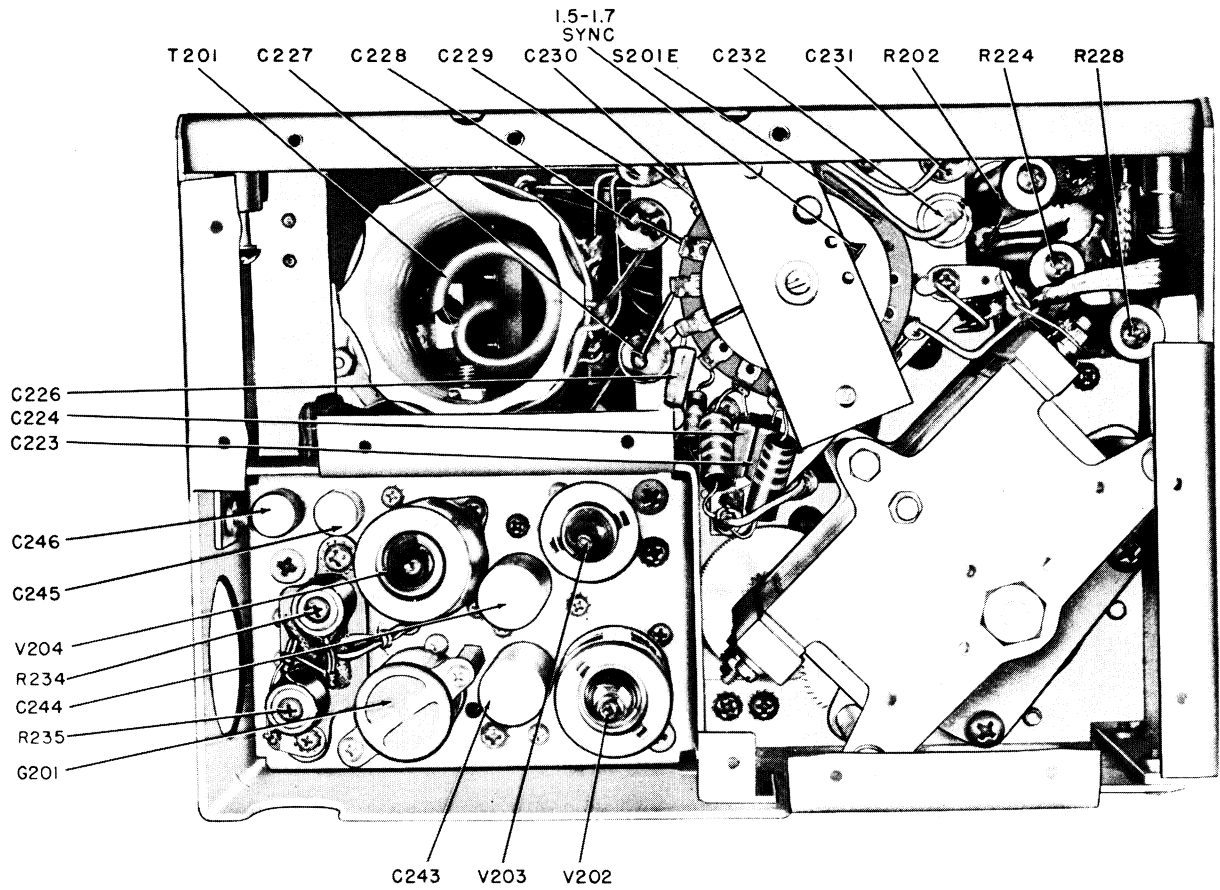

TM 806-82

Figure 79. Power-amplifier subchassis, rear view.

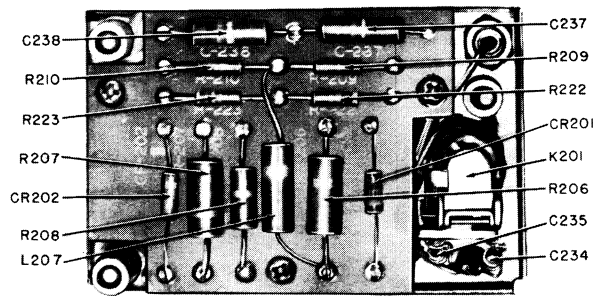

TM 806-84

Figure 80. Power-amplifier discriminator, bottom view.

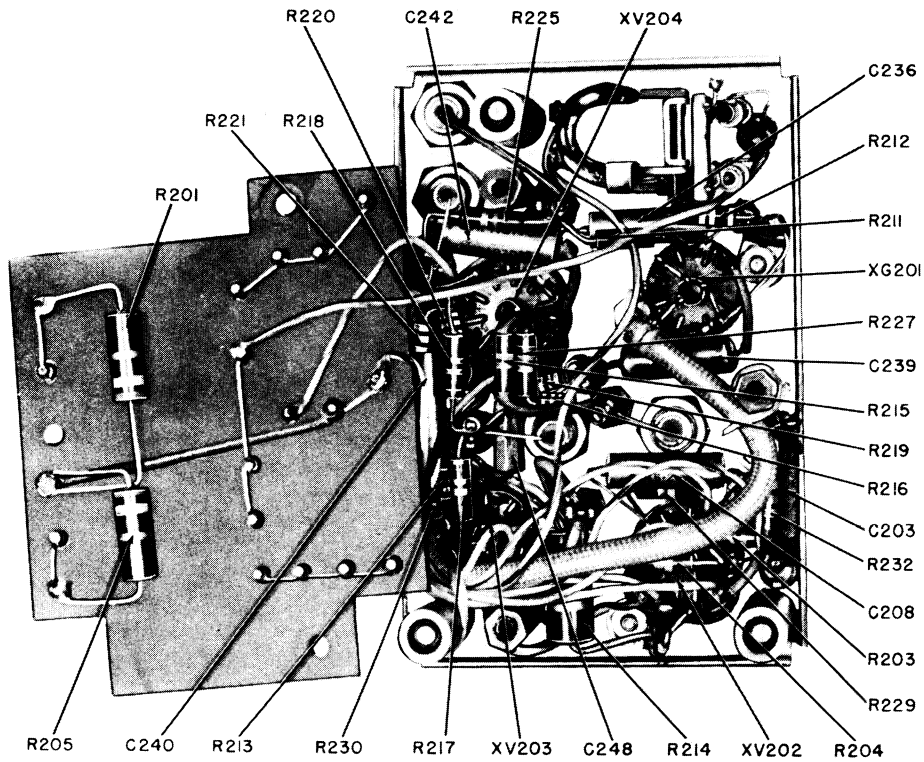

TM 806-86

Figure 81. Power-amplifier discriminator, terminal board.

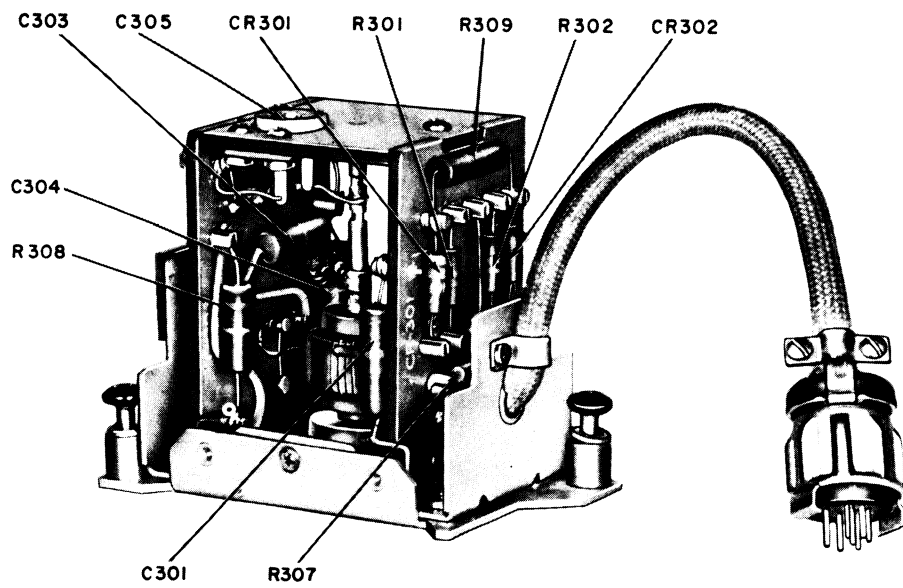

TM 806-64

Figure 82. Discriminator subchassis, right view.

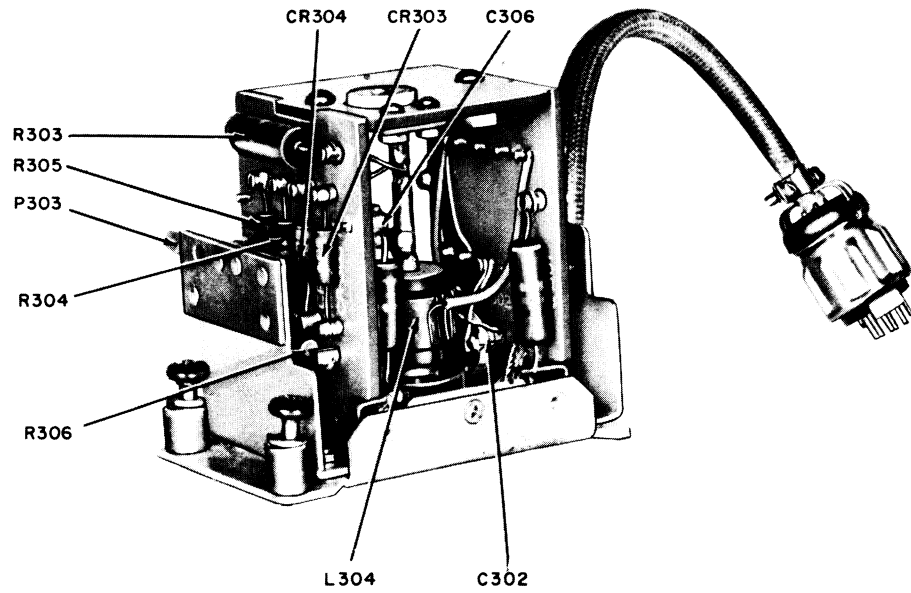

TM 806-65

Figure 83. Discriminator subchassis, left view.

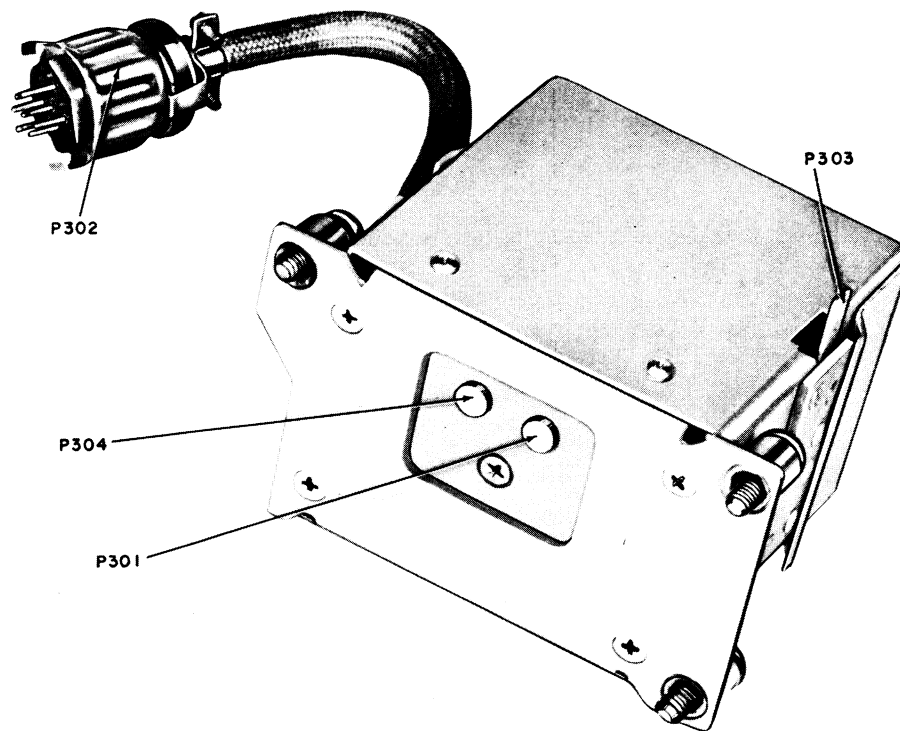

TM 806-66

Figure 84. Discriminator subchassis, bottom view.

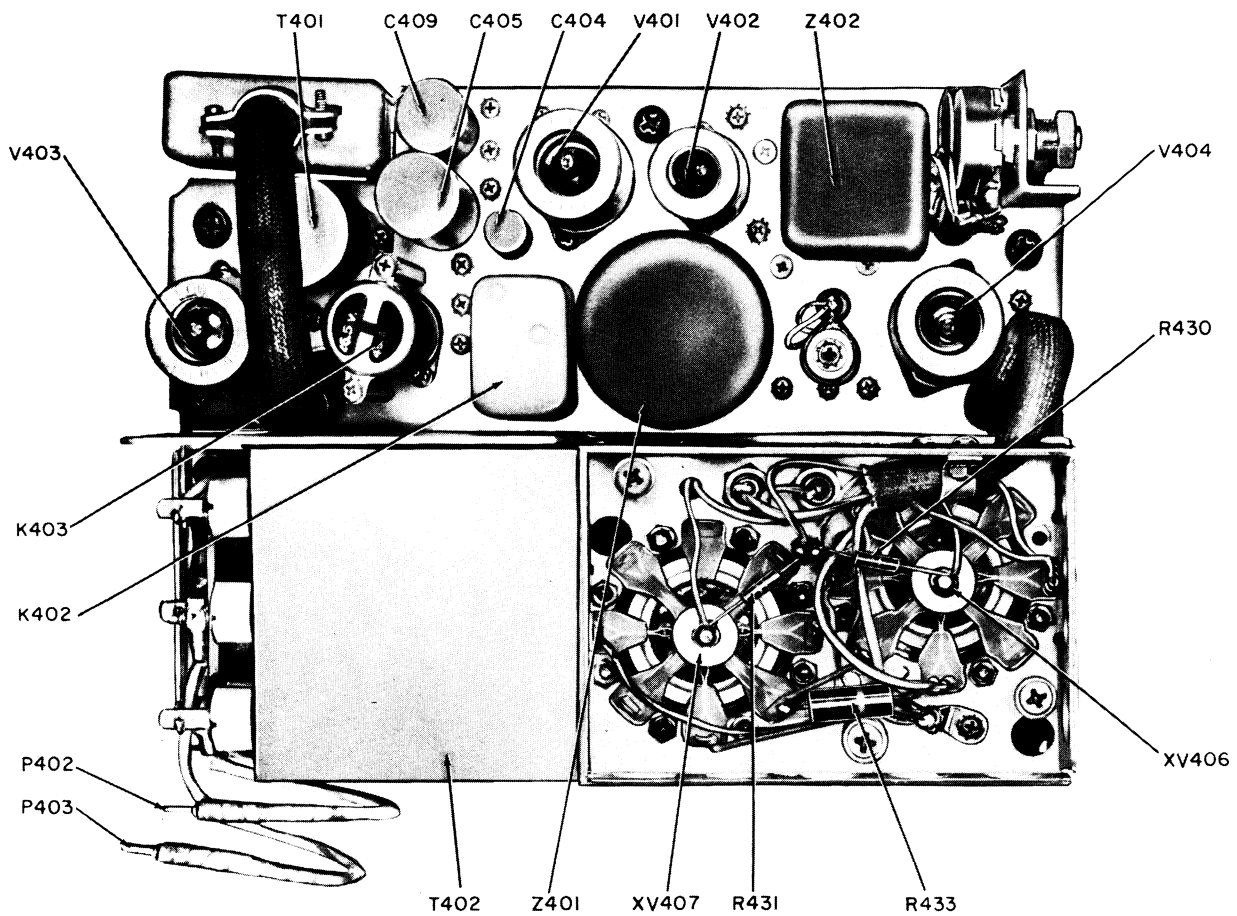

TM 806-68

Figure 85. Modulator subchassis, top view.

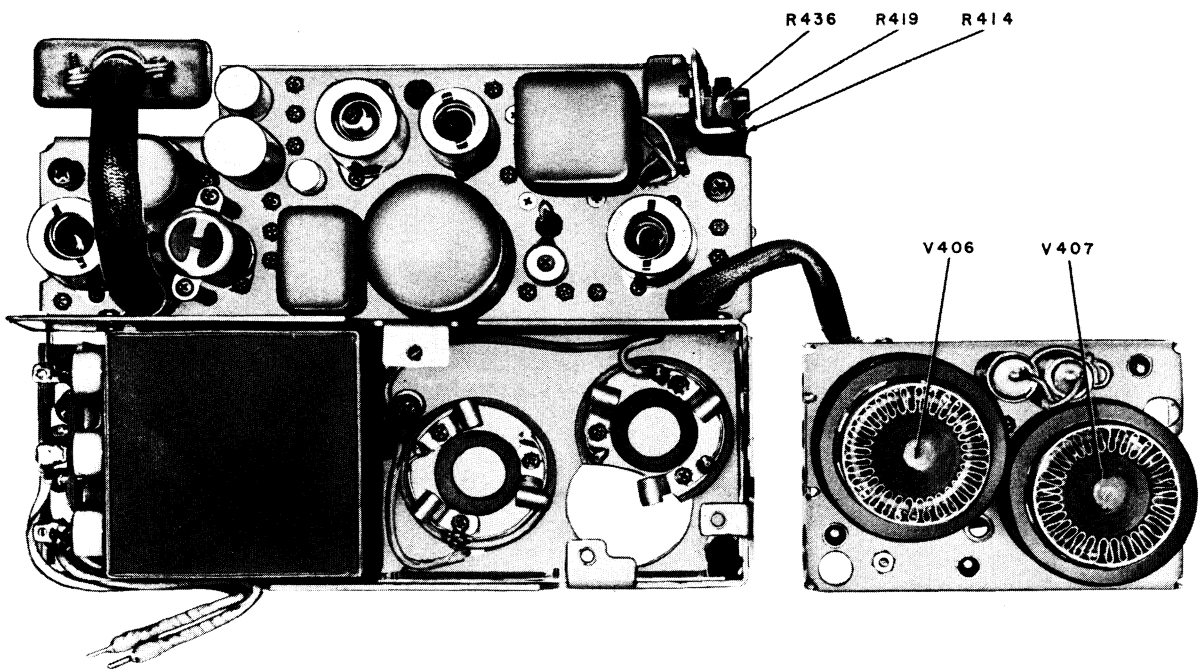
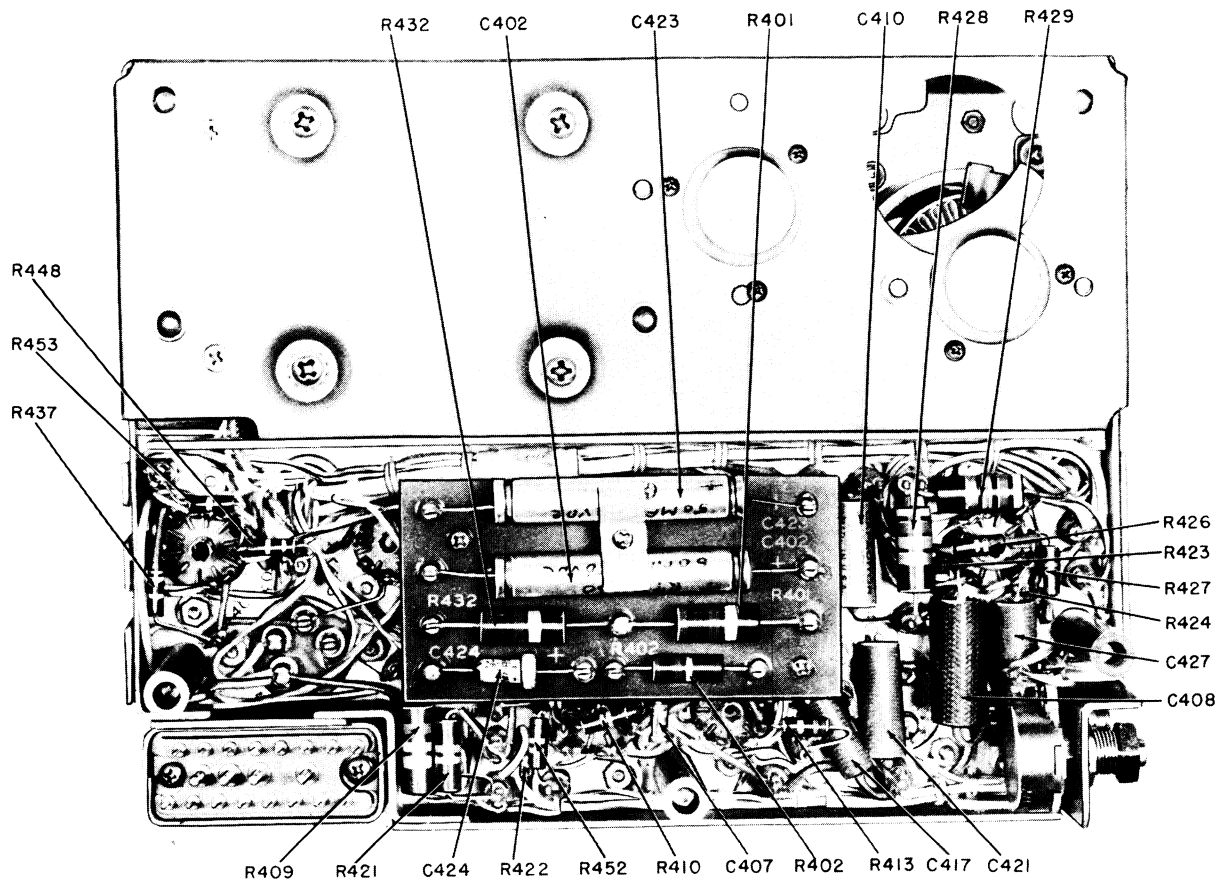

Figure 86. Modulator subchassis with modulator-tube subassembly removed.

TM 806-69



TM 806-70

Figure 87. Modulator subchassis, bottom view.

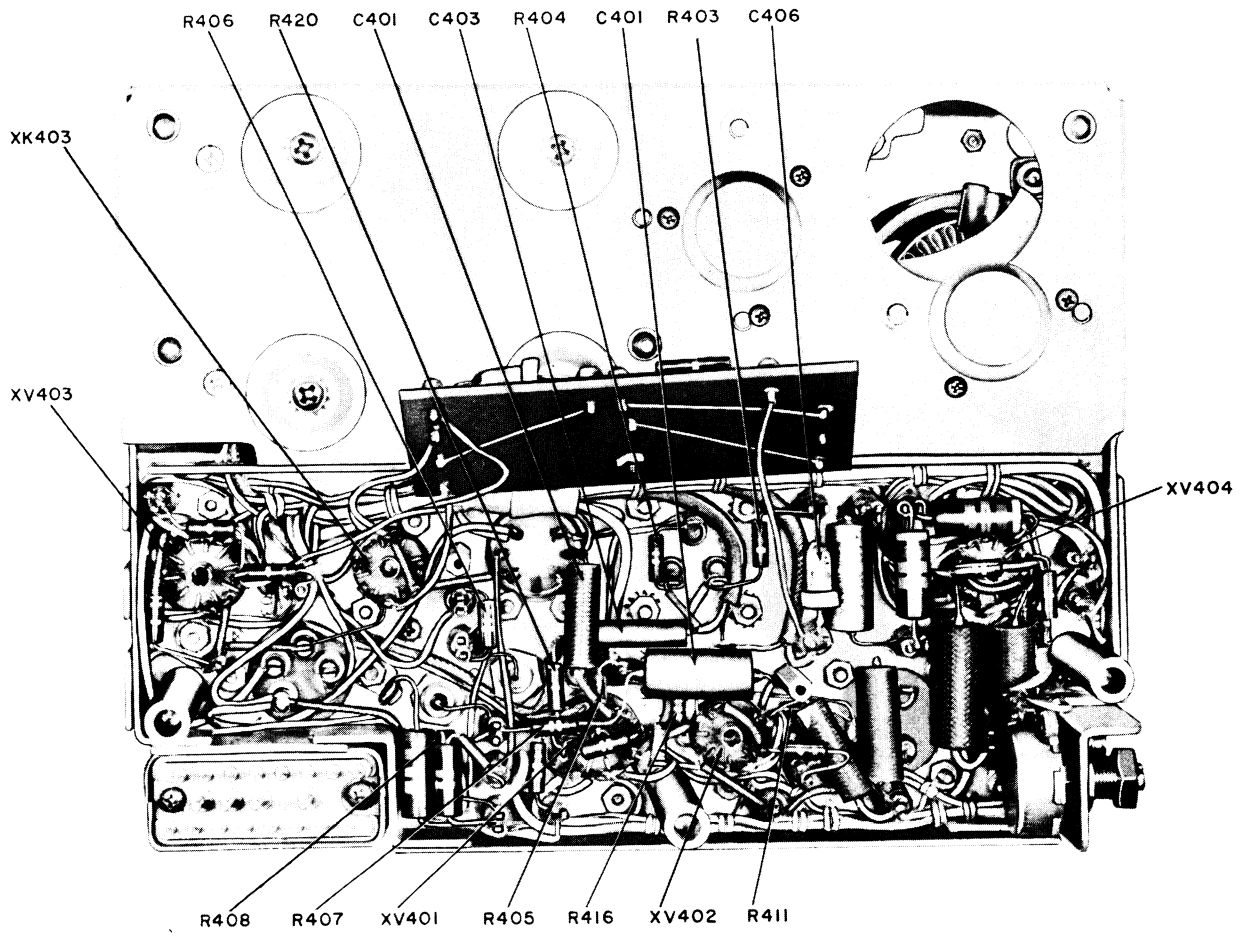

TM 806-71

Figure 88. Modulator subchassis, terminal board removed.

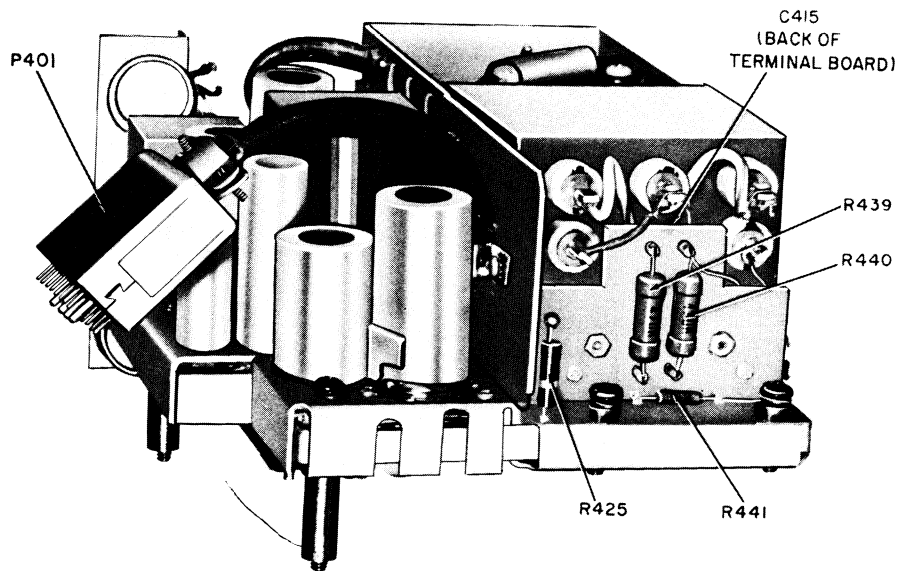

TM 806-67

Figure 89. Modulator subchassis, rear view.

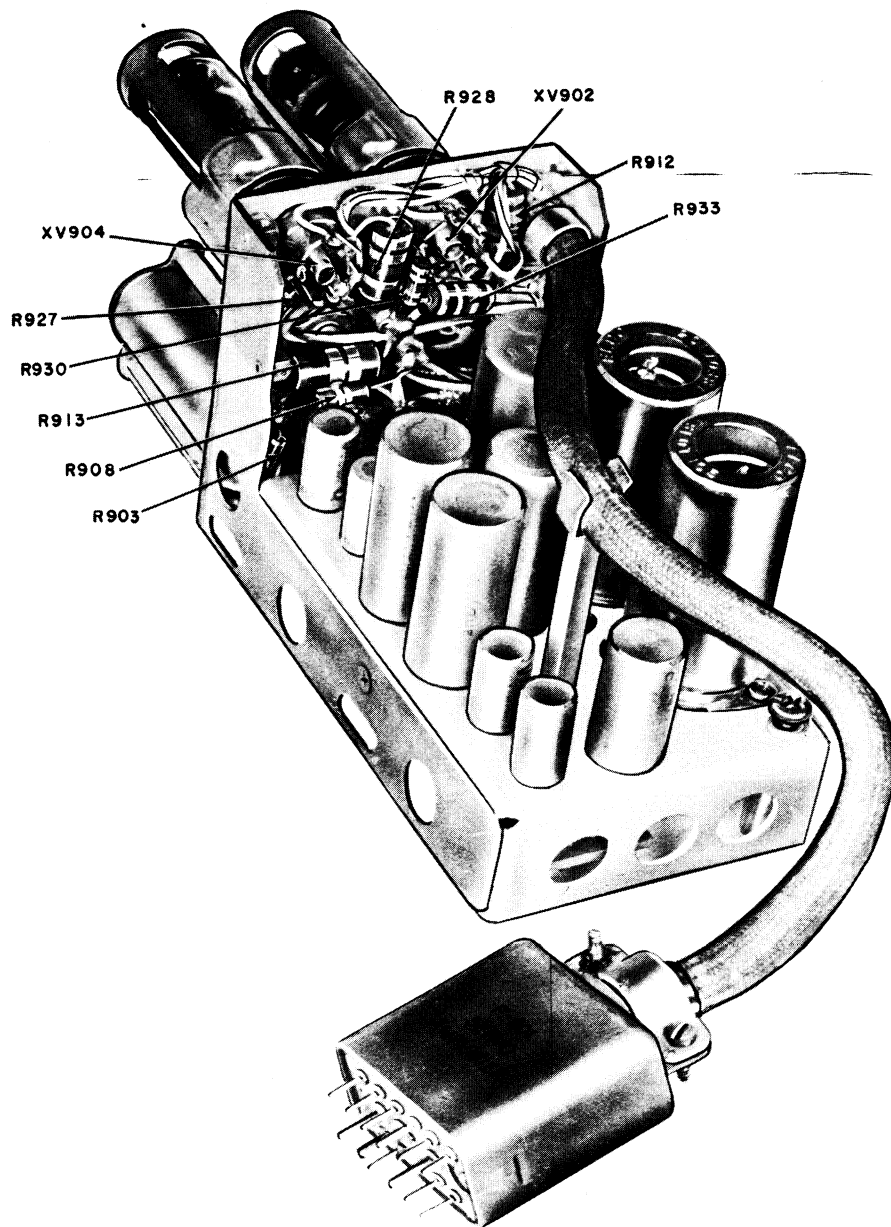

TM 806-88

Figure 90. Antenna network servo amplifier, cover removed, top view.

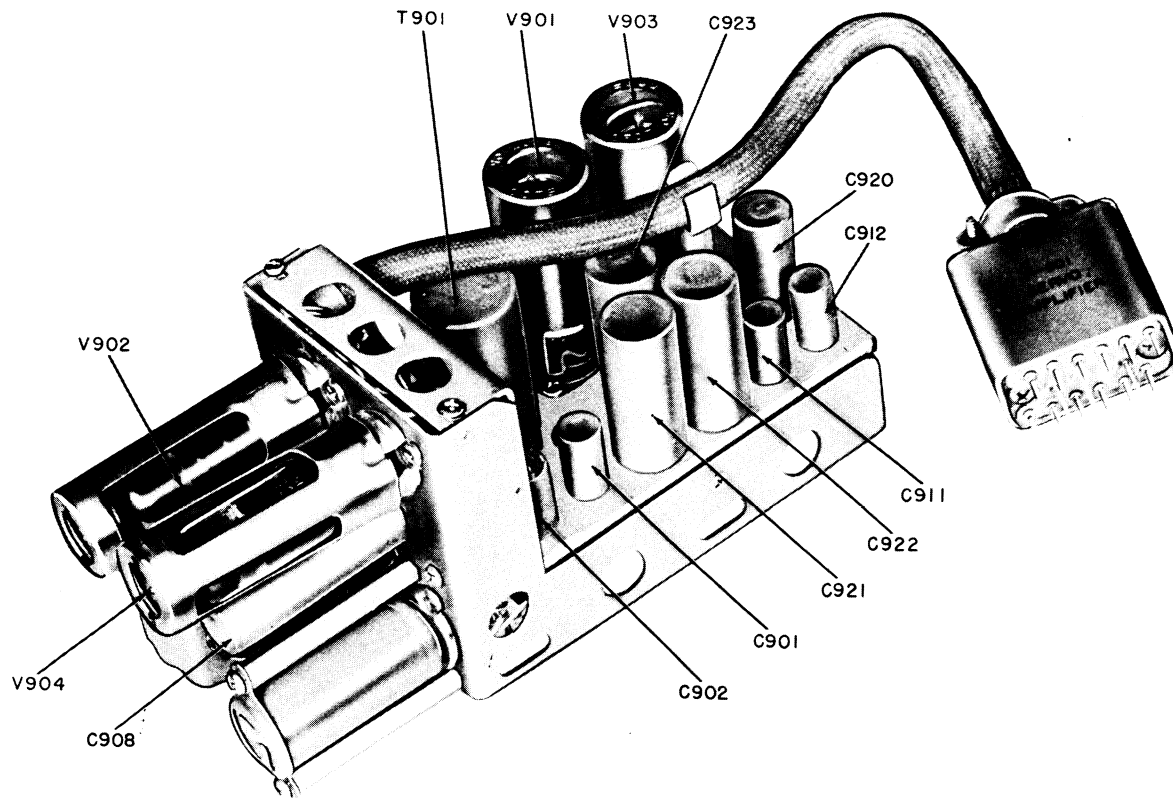

TM 806-76

Figure 91. Antenna network servo amplifier, oblique side view.

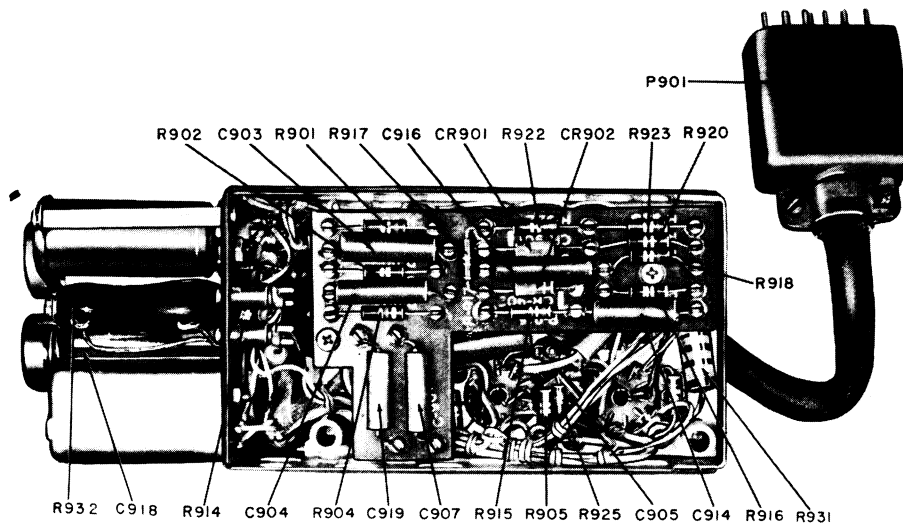

TM 806-74

Figure 92. Antenna network servo amplifier, bottom view.

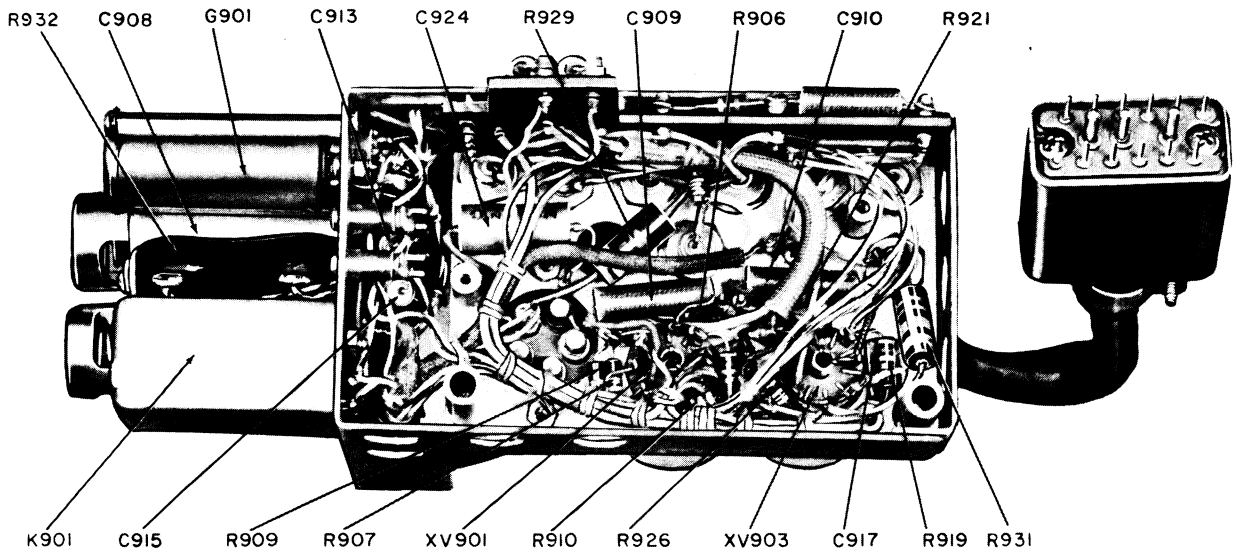

TM 806-75

Figure 93. Antenna network servo amplifier, terminal board removed.

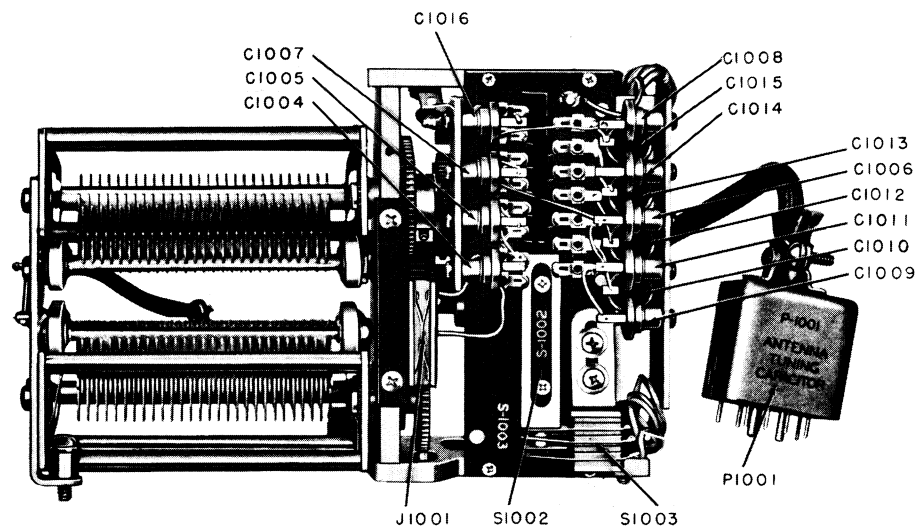

TM 806-63

Figure 94. Antenna tuning capacitor subchassis, right view.

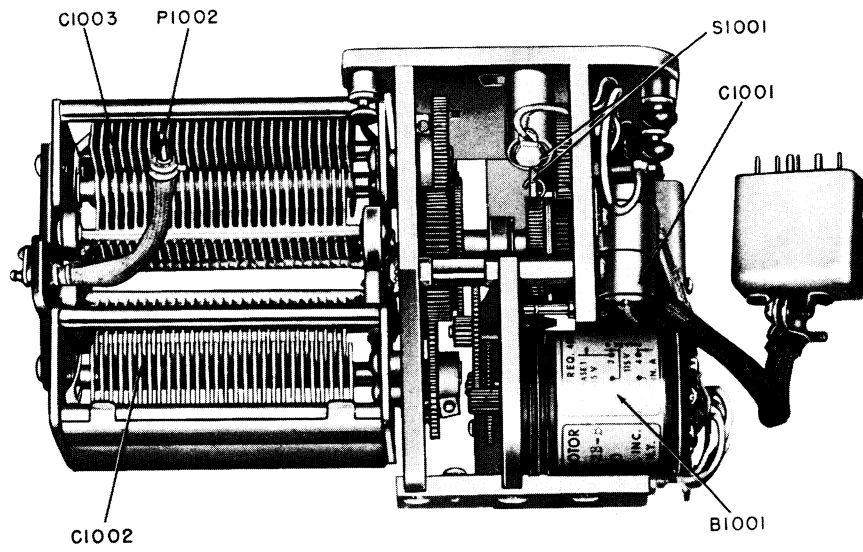

TM 806-62

Figure 95. Antenna tuning capacitor subchassis, left view.

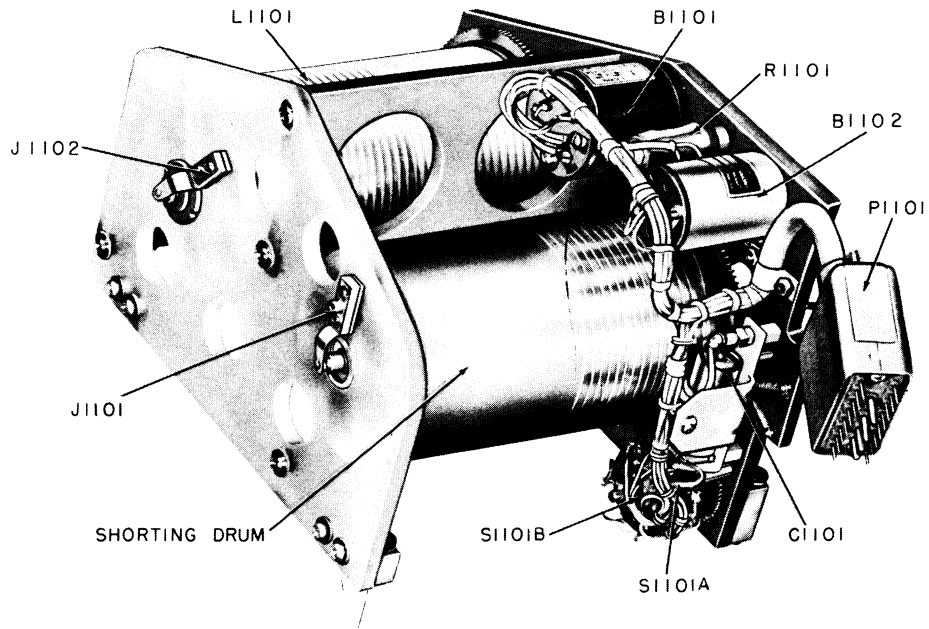

TM 806-61

Figure 96. Variable inductor subchassis.

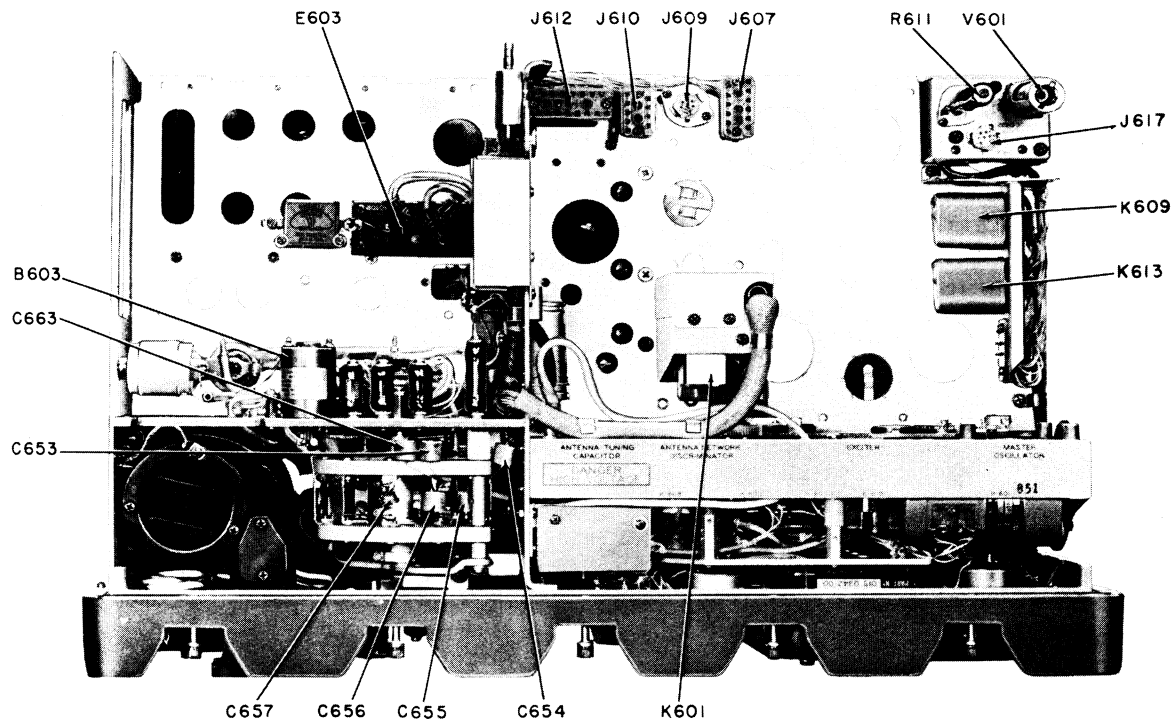

TM 806-99

Figure 97. Main frame, top view.

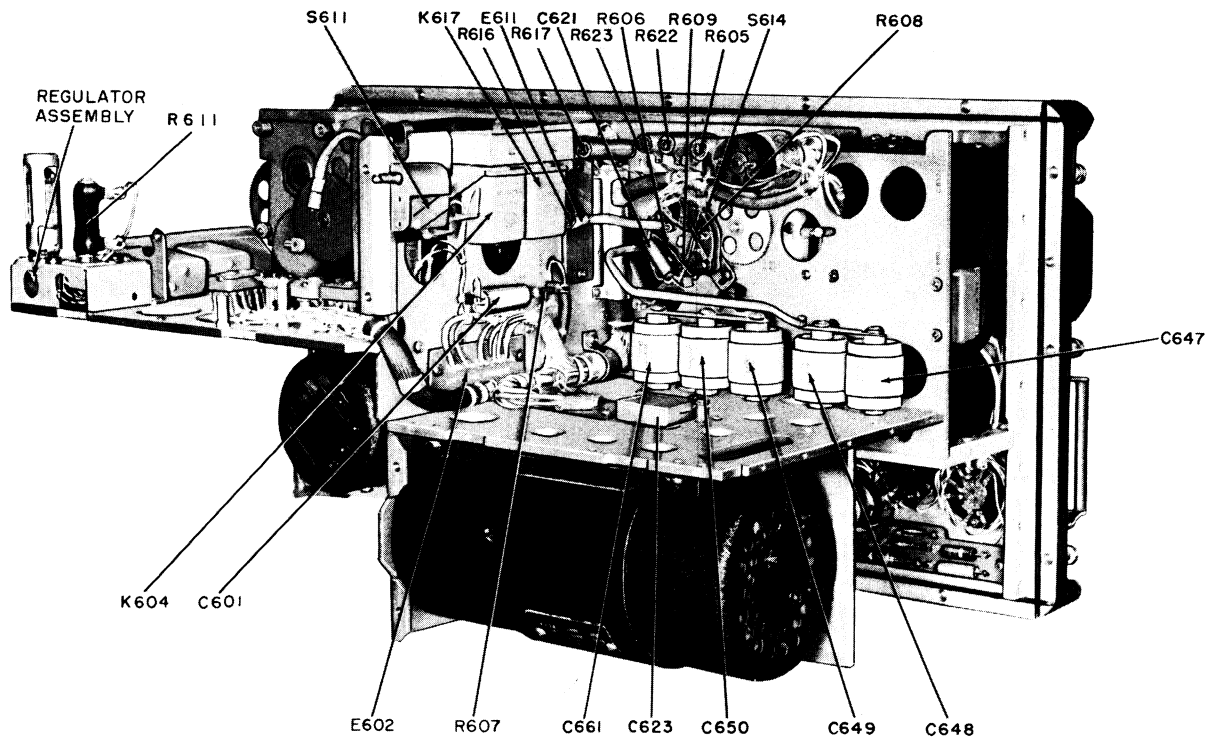

TM 806-100

Figure 98. Main frame, rear right view.

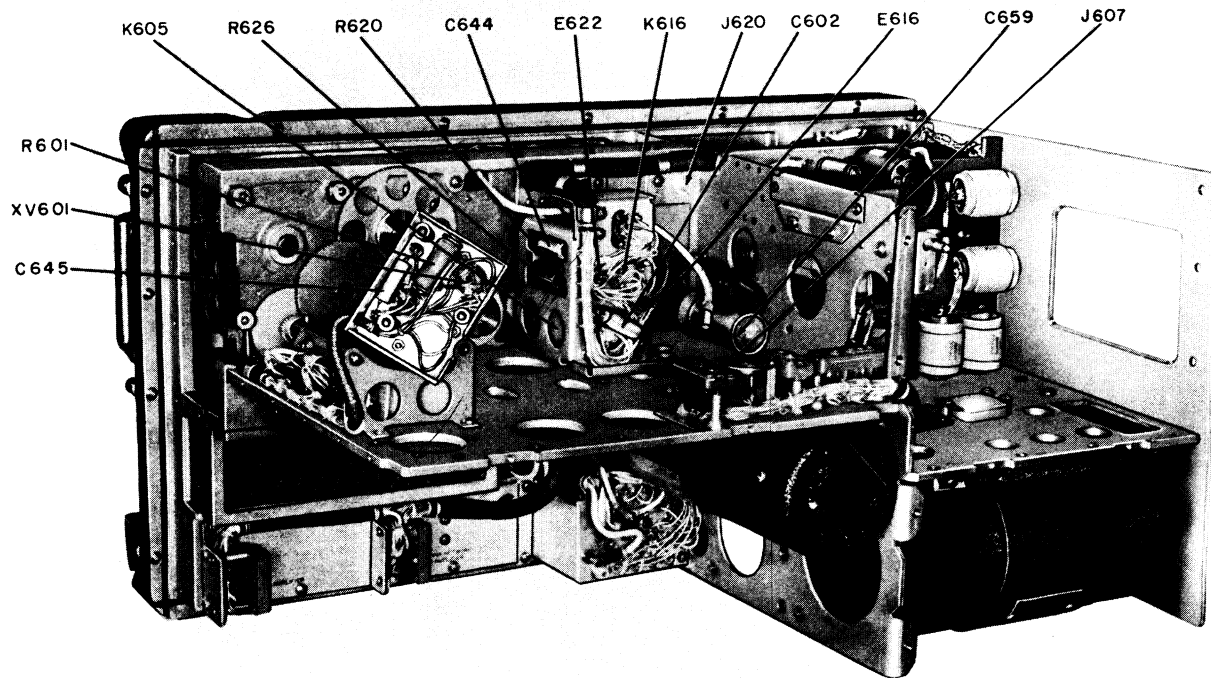

TM 806-101

Figure 99. Main frame, regulator subassembly removed.

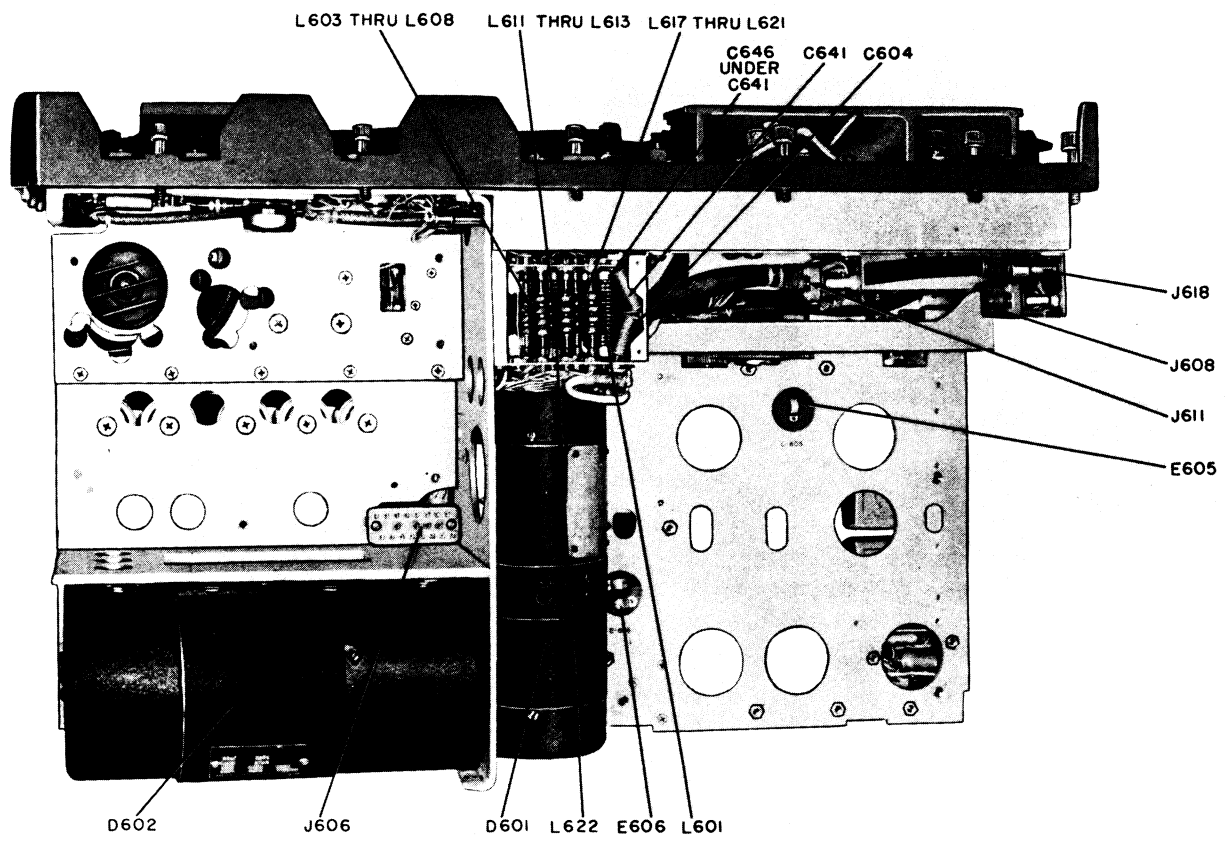
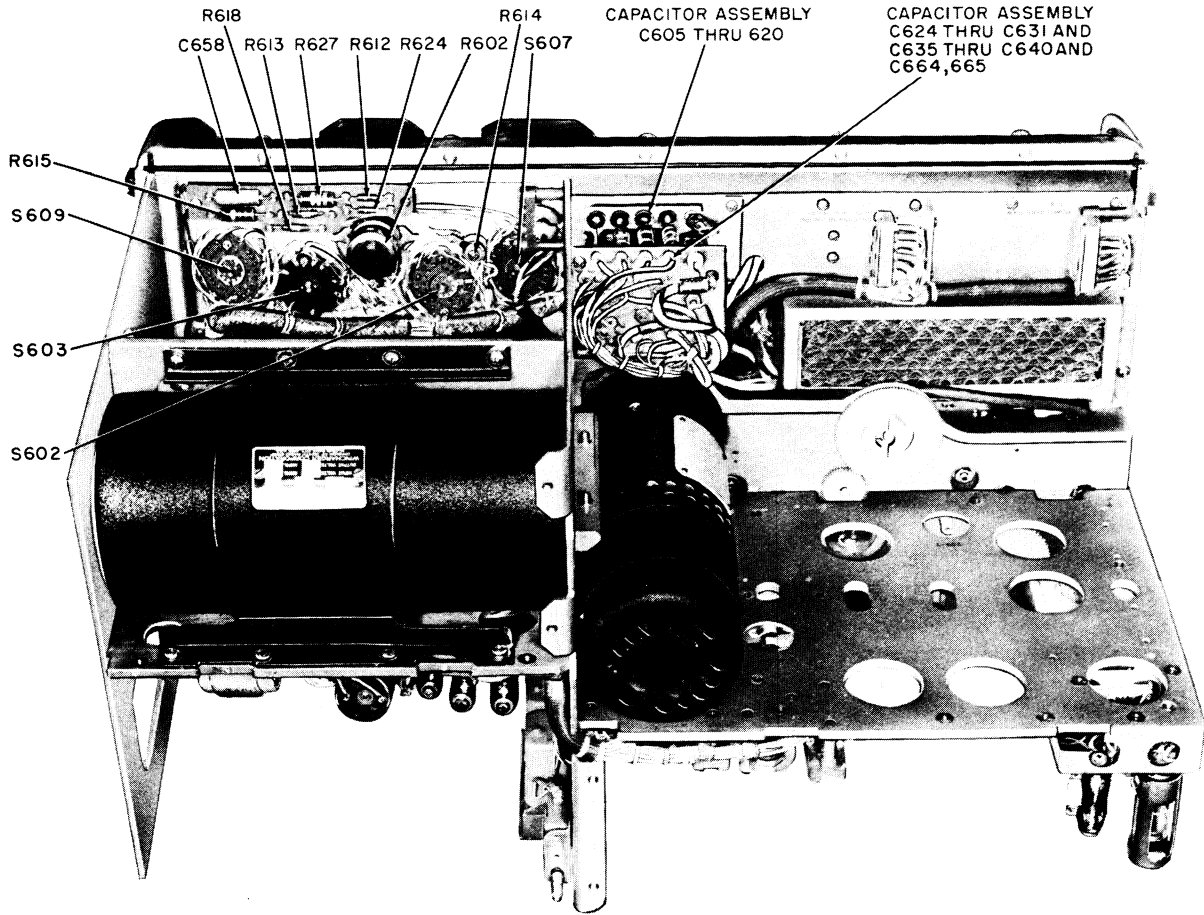

Figure 100. Main frame, bottom view.

TM806-102



TM 806-103

Figure 101. Main frame, bottom oblique view.

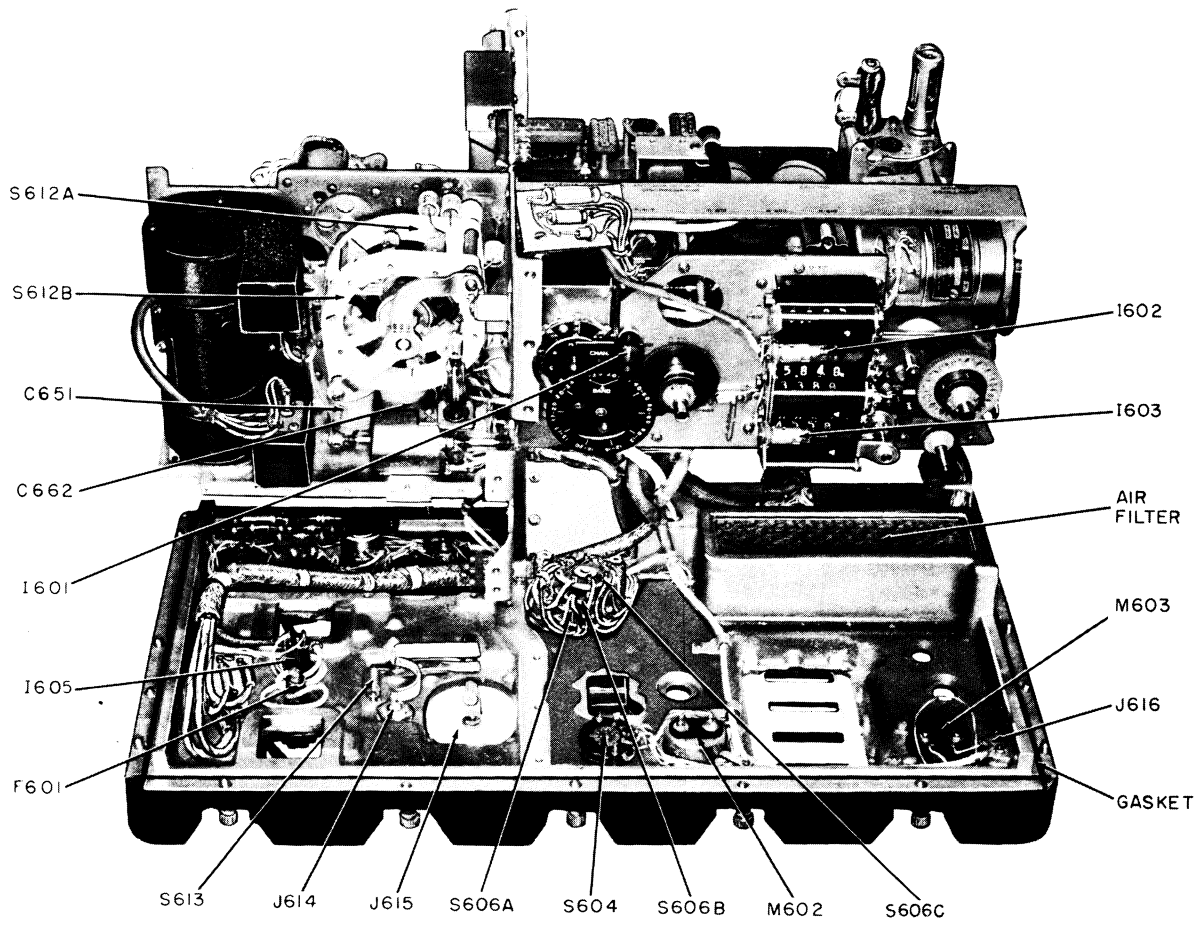

TM 806-97

Figure 102. Main frame, front panel removed.

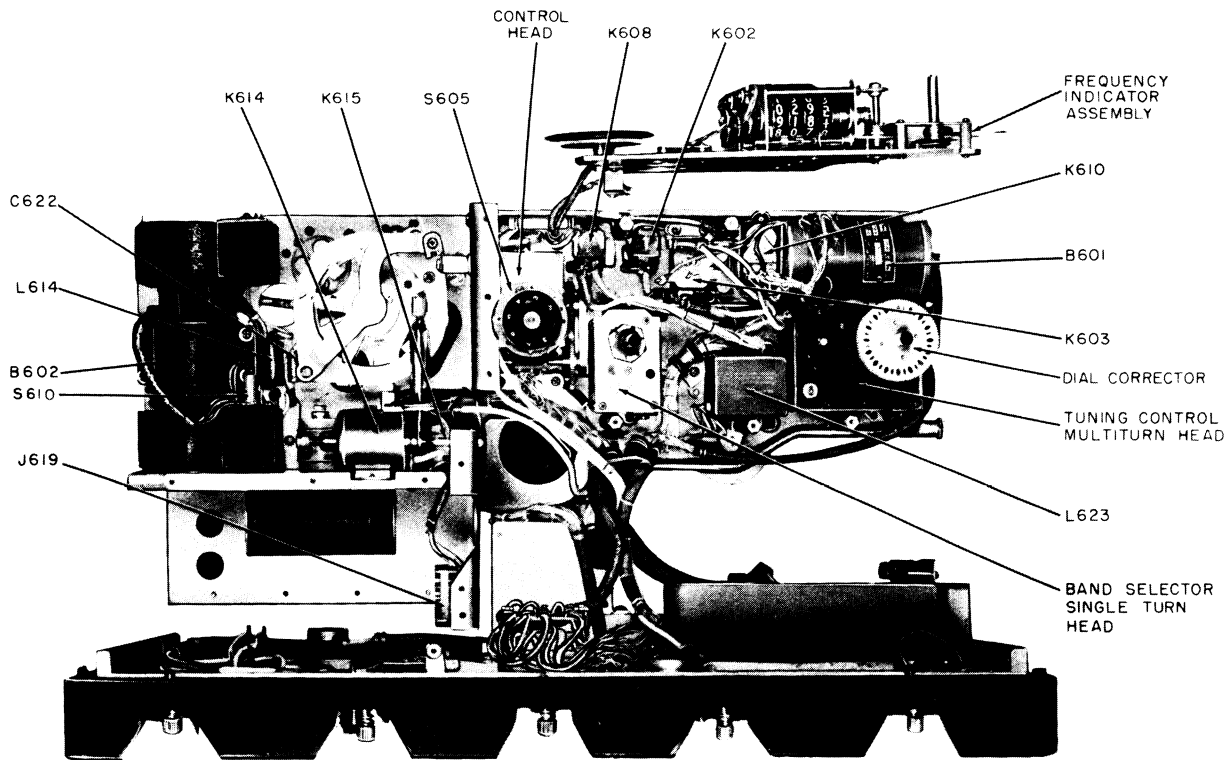

TM 806-98

Figure 103. Main frame, front panel and frequency indicator removed.

104. Voltage and Resistance Checks

Voltage and resistance diagrams for the various subchassis and main frame of the transmitter are shown in figures 104 through 111. These il-

lustrations show the values that should be obtained at the tube-socket pins and terminal boards. If a measured value varies more than 10 percent from the given value, closer examination of the involved circuits is necessary.

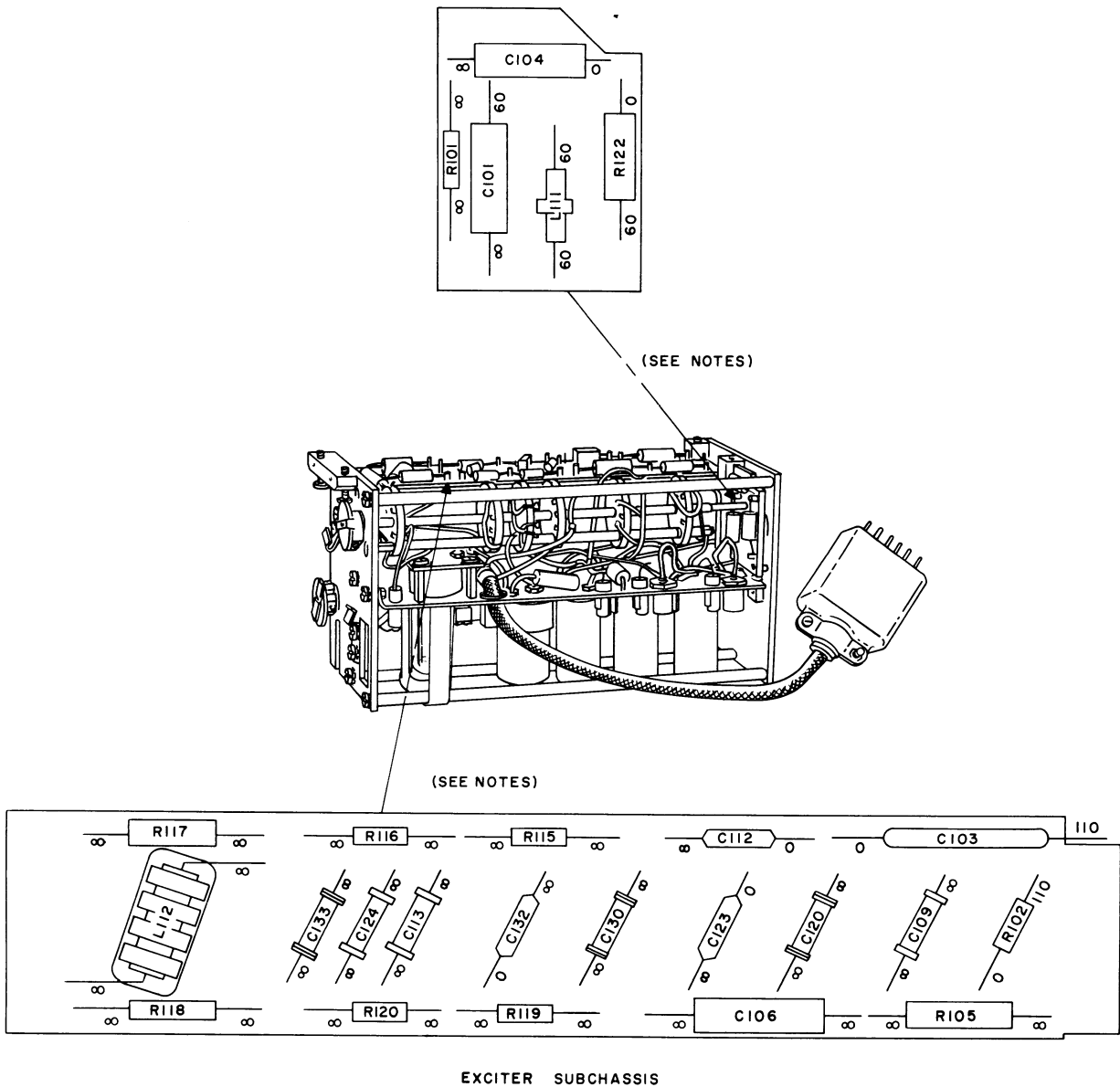

NOTES

- I. UNLESS OTHERWISE SHOWN, RESISTANCE IS SHOWN IN OHMS, AND ARE MEASURED FROM BOARD TERMINAL TO GROUND WITH A 20,000 OHMS-PER-VOLT METER
2. RESISTANCE MEASUREMENTS ARE FOR BAND I WITH EXCITER SUBCHASSIS DISCONNECTED.
3. INFINITY READINGS MAY DROP AS LOW AS 560K DEPENDING ON THE CONDITION OF ELECTROLYTIC CAPACITOR C146

TM 806-90

Figure 106. Exciter subchassis, terminal board measurements.

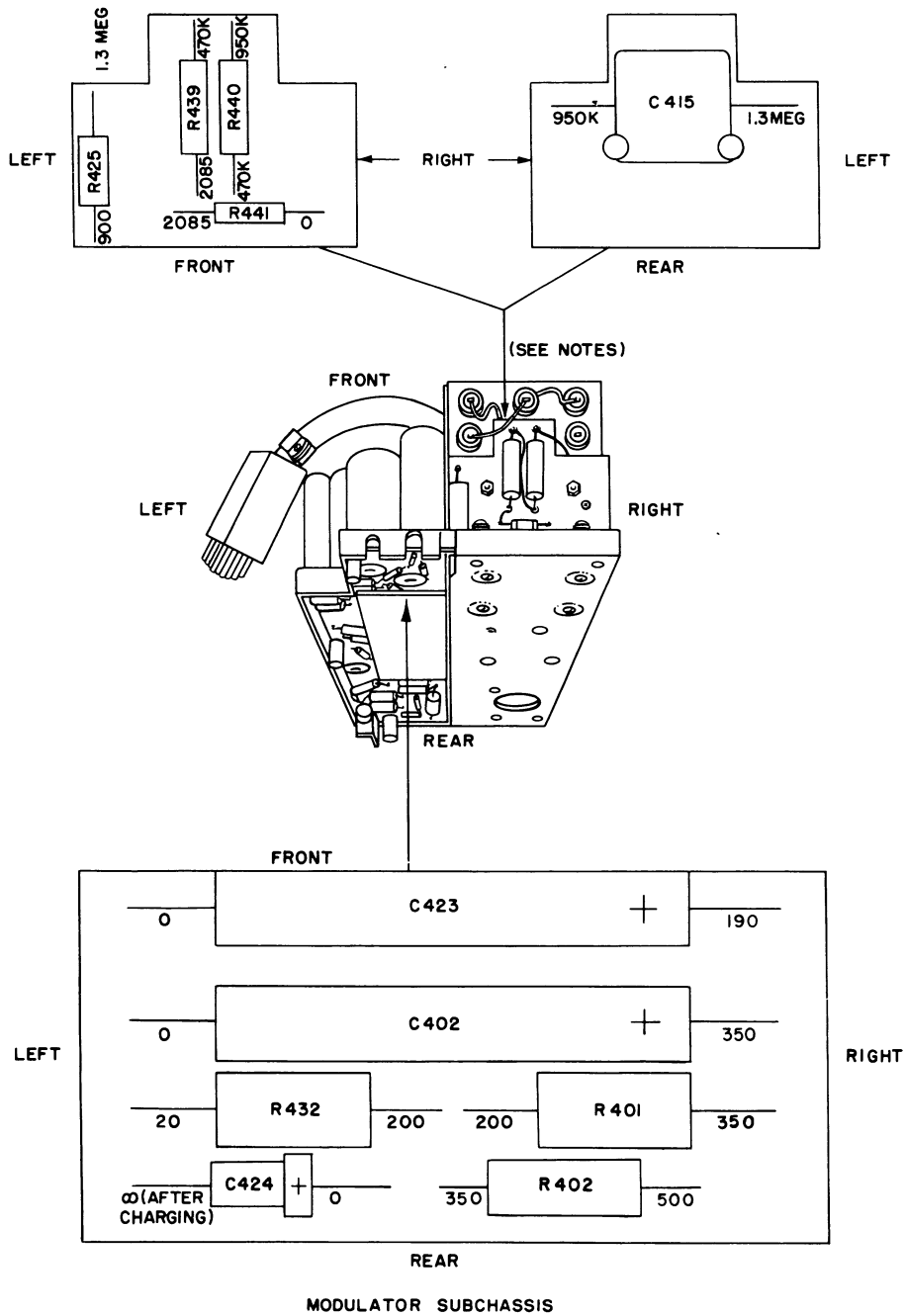

NOTES

1. UNLESS OTHERWISE SHOWN:
RESISTANCE IS IN OHMS, AND ARE MEASURED FROM BOARD
TERMINAL TO GROUND WITH A 20,000 OHMS-PER-VOLT
METER.
2. RESISTANCE MEASUREMENTS TAKEN WITH MODULATOR SUBCHASSIS
DISCONNECTED FROM TRANSMITTER.

TM 806-91

Figure 107. Modulator subchassis, terminal board measurements.

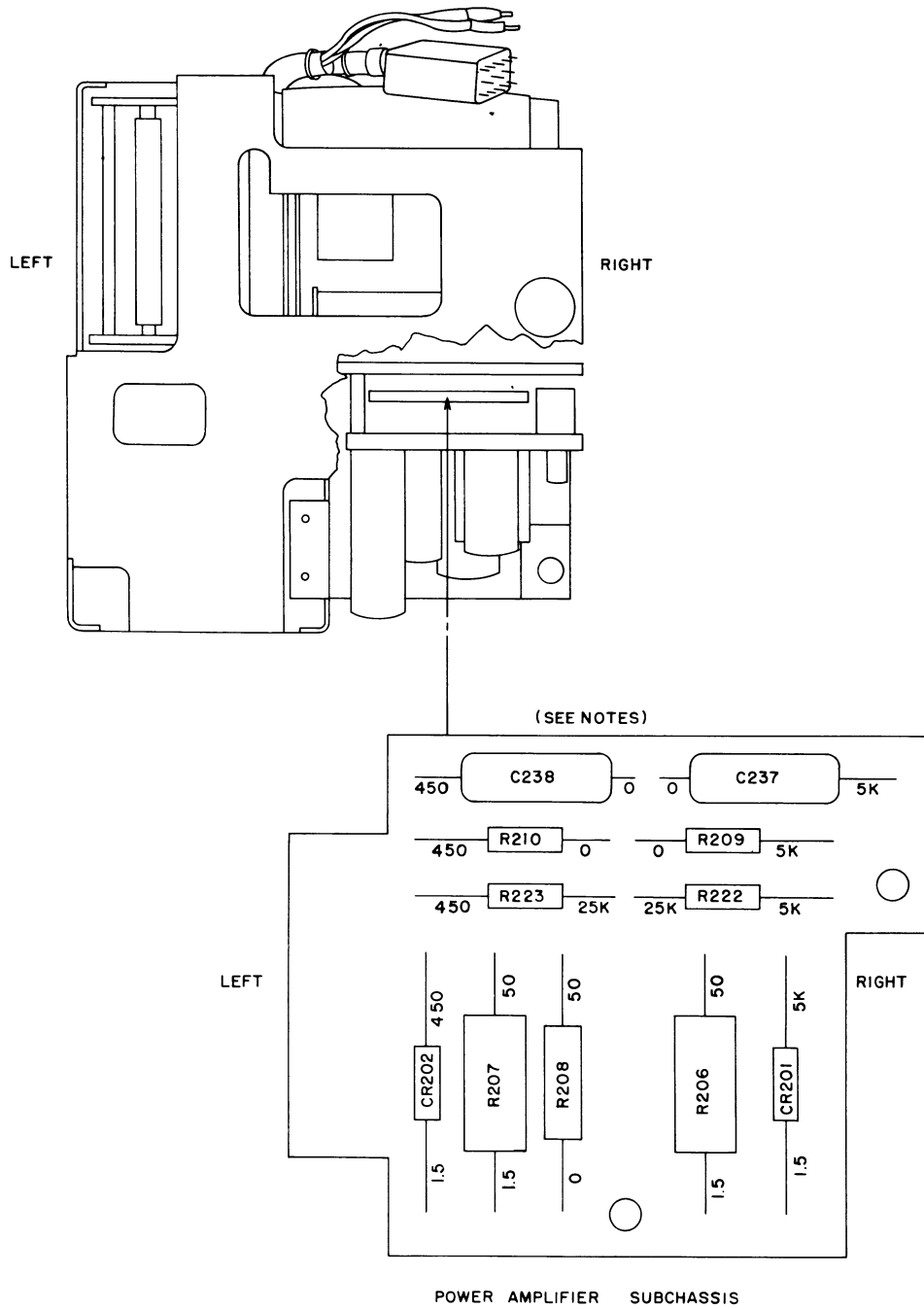

NOTES

1. UNLESS OTHERWISE SHOWN, RESISTANCE IS SHOWN IN OHMS, AND ARE MEASURED FROM BOARD TERMINAL TO GROUND WITH A 20,000 OHMS-PER-VOLT METER
2. RESISTANCE MEASUREMENTS TAKEN WITH POWER AMPLIFIER SUBCHASSIS DISCONNECTED FROM TRANSMITTER
3. ALL RESISTANCE VALUES WILL DEPEND ON POLARITY OF OHMMETER LEADS EXCEPT AT R207, R208, AND R206.

TM 806-60

Figure 108. Power-amplifier subchassis, terminal board measurements.

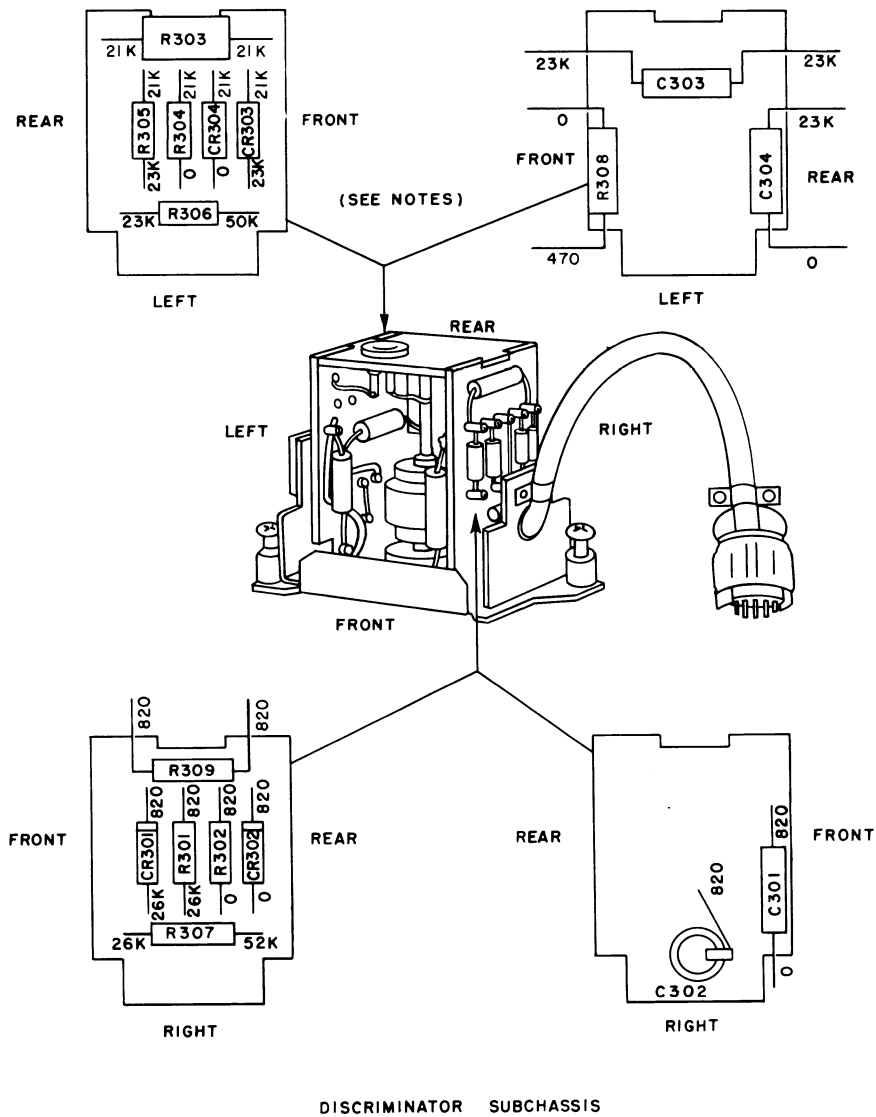

NOTES

1. UNLESS OTHERWISE SHOWN, RESISTANCE IS SHOWN IN OHMS, AND IS MEASURED FROM BOARD TERMINAL TO GROUND WITH A 20,000 OHMS-PER-VOLT METER

2. RESISTANCE MEASUREMENTS ARE TAKEN WITH DISCRIMINATOR SUBCHASSIS DISCONNECTED FROM TRANSMITTER.

TM 806-93

Figure 109. Discriminator subchassis, terminal board measurements.

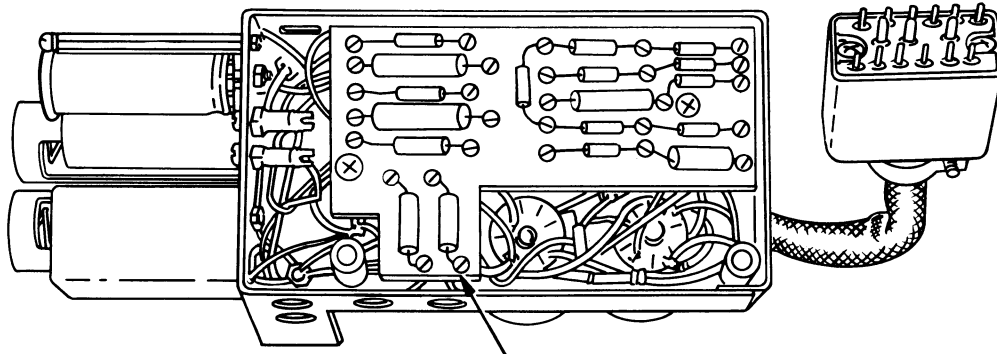

ANTENNA-NETWORK-SERVO-AMPLIFIER SUBCHASSIS

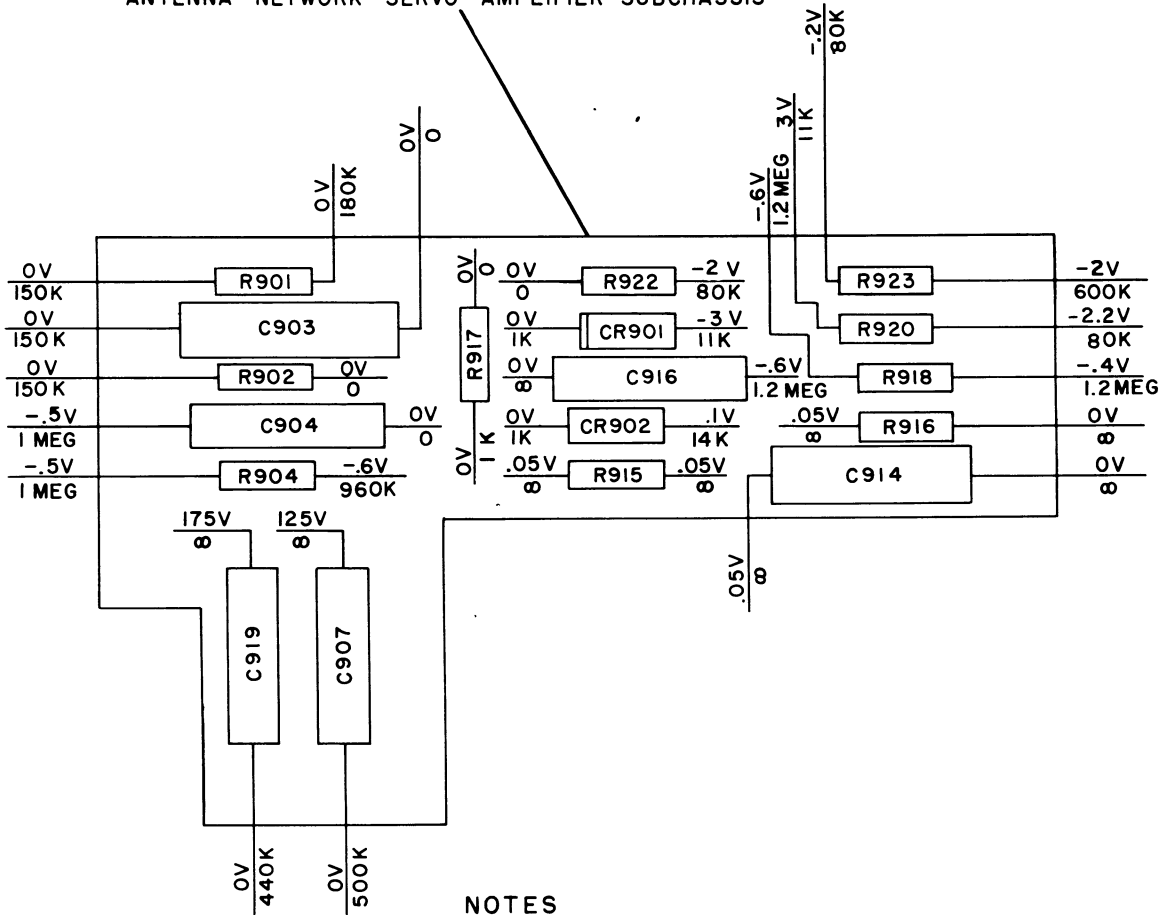

NOTES

1. UNLESS OTHERWISE SHOWN, RESISTANCE IS IN OHMS, AND IS MEASURED TO GROUND USING A 20,000 OHMS-PER-VOLT METER.
2. ALL VOLTAGES ARE DC AND ARE MEASURED TO GROUND USING A VTVM.
3. MEASUREMENTS ARE MADE WITH ANTENNA-NETWORK-SERVO-AMPLIFIER SUBCHASSIS DISCONNECTED.

TM 806-94

Figure 110. Antenna-network servo amplifier subchassis, terminal board measurements.

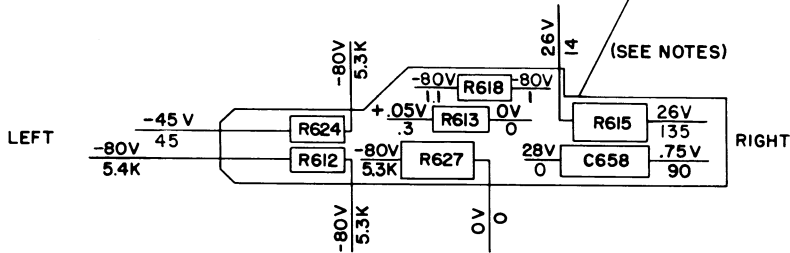
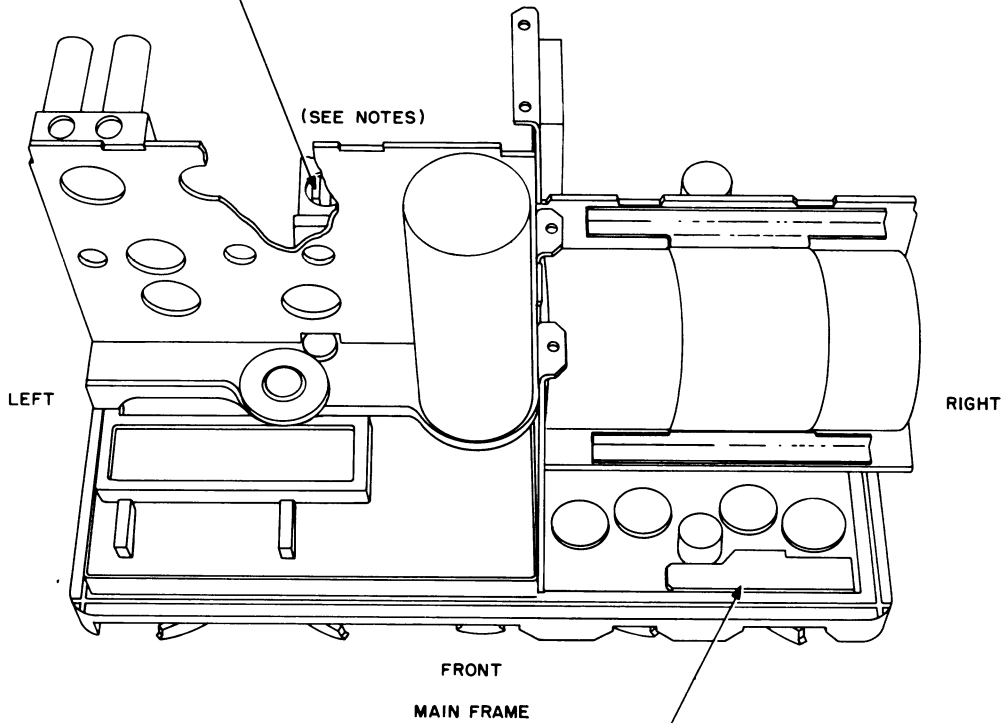
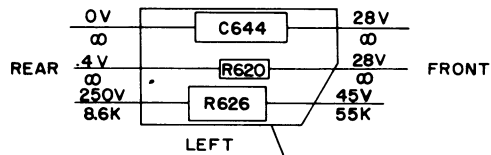

NOTES

1. UNLESS OTHERWISE SHOWN, RESISTANCE IS SHOWN IN OHMS, AND ARE MEASURED FROM BOARD TERMINAL TO GROUND WITH A 20,000 OHMS-PER-VOLT METER.
2. VOLTAGES ARE DC, AND ARE MEASURED FROM BOARD TERMINAL TO GROUND WITH A VTVM.
3. MEASUREMENTS ARE TAKEN WITH TEST KEY SWITCH HELD ON, TEST METER SWITCH TO PA CATH, SERVICE SELECTOR SWITCH TO CW, DIAL DIM SWITCH TO FULL, AND BAND SELECTOR AND TUNING CONTROL ADJUSTED TO 18 MC.

TM 806-95

Figure 111. Main frame, terminal board measurements.

105. Dc Resistances of Transformers, Coils, and Motors

The dc resistances of the subchassis and main frame are measured with each subchassis removed from the main frame. The dc resistances of the transformer windings, coils, and motors as measured with a 20,000 ohms-per-volt meter are listed below:

Item	Terminals	Ohms
L111	J101-J102	1.7.
L112		20.
Z101		Less than 1.0.
Z102		Less than 1.0.
Z103		Less than 1.0.
Z104		Less than 1.0.
Z105		Less than 1.0.
Z106		Less than 1.0.
Z107		Less than 1.0.
Z108		Less than 1.0.
Z109		Less than 1.0.
Z110		Less than 1.0.
B201	1-3	125.
	2-4	125.
B202		14.
K201		700.
K202		4.5.
K203		250.
L201		19.
L202		2.
L203		1.6.
L204 ^a		Less than 1.0.
L205		19.
L206		Less than 1.0.
L207		1.3.
S202		12.
L304A	Loading discriminator coil.	Less than 1.0.
L304B	Phasing discriminator coil.	Less than 1.0.
K402	1-6	250.
Z401	Input	72.
Z401	Output	10K.
Z402	Input	Infinite.
Z402	Output	Infinite.
T401	1-2	850.
T401	3-4	65.
B601	Armature	2.
	Field	18.
B602		1.5.
B603		15.
D601	+124 volt	4.
	+250 volt	7.
	-45 volt	2,500.
	115 volt, ac	16.
D602	+24 volt	Less than 1.
	+1,000 volt	180.
K601		8,000.
K602	2-1	108.

Item	Terminals	Ohms
K603		110.
K604		200.
K605		25.
K608		280.
K609		200.
K610		100.
K613		200.
K614		40.
K615		350.
K616		200.
K617		200.
L601		Less than 1.
L622		Less than 1.
L603		20.
	through L608.	
L611 through L613.		20.
L617 through L621.		20.
L623		30.
M602		Less than 1.
M603		3,900.
S608		0.
S610		150.
RT601		13.
L802		2.5.
S801		14.
G901 ^b	3-4	300.
K901 ^c	Across relay coil	800.
	Across relay coil	7,500.
T901	1-2	480.
	3-5	2.
B1001 and B1101.	2-5	75.
	4-6	75.
	2-4	150.
	1-3	150.
B1102		7.5.

^a Resistance too low for reading.

^b Reading taken with G901 removed from socket XG901.

^c Two readings taken when reversing the ohmmeter leads. For convenience, connect the leads to the plate of CR901 and the cathode of CR902 (fig. 92).

106. Resistance Measurements of Receptacles and Connectors

Notes. Readings were taken under the following conditions:

1. Readings taken with 20,000-ohm voltmeter.
2. All readings from indicated point to ground.
3. Transmitter on band No. 1.
4. Frequency at 1.5 mc.
5. LINE LEVEL control completely clockwise.
6. SERVICE SELECTOR in OFF position.
7. DIAL DIM switch in FULL position.
8. RELAY-NORMAL-DUPLEX switch in NORMAL position.

9. TEST METER IN PA CATH position.
10. No external connections to equipment.
11. Variable inductor at maximum inductance.
12. Connector under test electrically disconnected.

Connector	Pin or socket No.	Resistance (ohms)
J606	1	Infinite.
	2	Infinite.
	3	Infinite.
	4	20,000.
	5	38.
	6	Infinite.
	7	50 K.
	8	Infinite.
	9	50 K.
	10	Infinite.
	11	90.
	12	Infinite.
	13	150 K.
	14	300.
	15	Infinite.
	16	Infinite.
	17	0.
	18	2.5.
	19	Infinite.
	20	2.5.
P401	1	45.
	2	Infinite.
	3	Infinite.
	4	75.
	5	Infinite.
	6	2,100.
	7	Infinite.
	8	Infinite.
	9	Infinite.
	10	500.
	11	Infinite.
	12	60.
	13	Infinite.
	14	280.
	15	Infinite.
	16	Infinite.
	17	0.
	18	200.
	19	Infinite.
	20	3.
J607	1	200.
	2	200.
	3	200.
	4	200.
	5	Infinite.
	6	40.
	7	Infinite.
	8	Infinite.
	9	Infinite.
	10	Infinite.
	11	Less than 1.
	12	Infinite.
	13	90.
	14	Infinite.
	15	0.

Connector	Pin or socket No.	Resistance (ohms)
P101	1	0.
	2	Infinite.
	3	0.
	4	Infinite.
	5	Infinite.
	6	Infinite.
	7	0.
	8	Infinite.
	9	Infinite.
	10	Infinite.
	11	55.
	12	0.
	13	370 K.
	14	60.
	15	0.
J609	A	Infinite.
	B	600 K.
	C	Infinite.
	D	0.
	E	Infinite.
	F	600 K.
	H	Infinite.
P302	A	Infinite.
	B	60 K.
	C	Infinite.
	D	0.
	E	Infinite.
	F	60 K.
	H	Infinite.
J608	1	240.
	2	2.
	3	Infinite.
	4	200.
	5	Less than 1.
	6	0.
	7	Infinite.
	8	250.
	9	90.
	10	5,200.
	11	2.
	12	14.
	13	5.
	14	Infinite.
	15	0.
P201	1	300.
	2	5.
	3	270 K.
	4	Infinite.
	5	Infinite.
	6	500.
	7	900 K.
	8	2.
	9	1.1 meg.
	10	360 K.
	11	160.
	12	160.
	13	5.
	14	Less than 1.
	15	0.

Connector	Pin or socket No.	Resistance (ohms)
J611	1	500 K.
	2	0.
	3	0.
	4	28.
	5	12.
	6	39.
	7	250.
	8	270.
	9	45.
	10	Infinite.
	11	90.
	12	90 K.
	13	Infinite.
	14	4.
	15	4.
P901	1	180 K.
	2	75 K.
	3	0.
	4	Infinite.
	5	4.4 K.
	6	Infinite.
	7	Infinite.
	8	Infinite.
	9	Infinite.
	10	60 K.
	11	Infinite.
	12	Infinite.
	13	2.0.
	14	Infinite.
	15	20.
J610	1	Infinite.
	2	7,000.
	3	200.
	4	Infinite.
	5	Infinite.
	6	100 K.
	7	0.
	8	90.
	9	13.
	10	Infinite.
	11	0.
P1001	1	Infinite.
	2	Infinite.
	3	Infinite.
	4	Infinite.
	5	Infinite.
	6	0.
	7	Infinite.
	8	Infinite.
	9	170.
	10	Infinite.
	11	0.
J612	1	Infinite.
	2	Infinite.
	3	Infinite.
	4	Infinite.
	5	0.
	6	Infinite.
	7	Infinite.
	8	Infinite.

Connector	Pin or socket No.	Resistance (ohms)	
J612—Continued	9	Infinite.	
	10	Infinite.	
	11	Infinite.	
	12	180.	
	13	Infinite.	
	14	Infinite.	
	15	Infinite.	
	16	Infinite.	
	17	90.	
	18	0.	
	19	Infinite.	
	20	14.	
	P1101	1	Infinite.
		2	Infinite.
		3	Infinite.
		4	Infinite.
		5	Infinite.
		6	Infinite.
		7	Infinite.
		8	Infinite.
9		Infinite.	
10		Infinite.	
11		Infinite.	
12		Infinite.	
13		Infinite.	
14		Infinite.	
15		Infinite.	
16		Infinite.	
17		Infinite.	
18		Infinite.	
19		Infinite.	
20		Infinite.	
J617	A	3,000.	
	B	Infinite.	
	C	60.	
	D	0.	
	E	5.	
	F	5.	
	H	0.	
P802	A	Infinite.	
	B	Infinite.	
	C	6.	
	D	0.	
	E	Infinite.	
	F	Infinite.	
	H	0.	
REMOTE CONT J601	A	Infinite.	
	B	57.	
	C	Infinite.	
	D	Infinite.	
	E	Infinite.	
	F	Infinite.	
	H	Infinite.	
	J	430.	
	K	14.	
	L	Infinite.	
	M	Infinite.	
	N	Infinite.	
P	Infinite.		
R	0.		

Connector	Pin or socket No.	Resistance (ohms)
J601—Continued	S	Infinite.
	T	Infinite.
	U	Infinite.
	V	Infinite.
	W	Infinite.
AUDIO J603	A	57.
	B	0.
	C	430.
	D	Infinite.
	E	0.
	F	Infinite.
	H	0.
	J	Infinite.
	K	Infinite.
	L	Infinite.
	RECEIVER CONT J604	A
B		Infinite.
C		430.
D		Infinite.
E		0.
F		Infinite.
H		57.
J		Infinite.
K		Infinite.

Connector	Pin or socket No.	Resistance (ohms)
24 VOLTS DC J605	A	Infinite.
	B	Infinite.
	C	0.
	D	0.
WHIP ANTENNA J615. RECEIVER ANTENNA J616.		Infinite.
		Infinite.

107. Testing Crystals

After each 250 hours of operation, test the following germanium crystals with an ohmmeter: CR201 and CR202 in the power-amplifier subchassis (fig. 80); CR301 and CR302 (fig. 82); CR303 and CR304 in the discriminator subchassis (fig. 83). The condition of any one of these crystals is satisfactory when its forward resistance is less than 1,500 ohms and its backward resistance is greater than 20,000 ohms. The forward and backward resistances of each crystal in a balanced pair (CR201/CR202 and CR301/CR302) should be within 10 percent of each other.

Section II. REPAIRS AND LUBRICATION

108. Removals and Replacements

In *a* through *y* below directions for removing and replacing the subchassis and various detail parts of the transmitter for benchtesting or repair. Avoid changing the positions of the tuning, switching, or potentiometer shafts while any of the subchassis which have such controls are removed from the main frame. Disturbance of any of the controls indicated in the following procedures may necessitate synchronization or realignment. Subchassis mounting screws are color-coded with green heads. In most cases, these are captive screws, and need be loosened only until they are free of the main frame. When replacing the subchassis, the captive screws should first be started one at a time, in order to locate the subchassis before tightening the screws all the way. To remove a coaxial plug, press the plug in slightly and twist counterclockwise to release it; then pull the plug straight out. If coaxial plugs are not accessible, use scissor-type Tube Puller TL-201, supplied with Tool Equipment TE-113, to remove the plugs. To remove plug P302 of the antenna-network discriminator subchassis or plug

P802 of the master-oscillator subchassis, twist the metal shell slightly counterclockwise to release the clamp, and then pull the plug. When replacing multicontact plugs, be sure that the pins are properly aligned with the receptacle contacts, because the pins are easily bent. When loosening the clamp screws on the plugs attached to the front panel, be careful not to overdraw the screws and let the nuts drop off. Do not tighten clamp screws too far, because the threads will be stripped. When using the Bristo wrench, be sure that it is fully inserted into the screw to avoid stripping of the slots in the head.

a. Removal of Front Panel. To gain access to the wiring and parts on the back of the front panel (fig. 102), remove the front panel as follows:

- (1) If the transmitter is installed on a mounting, loosen the three front clamping devices and slide the transmitter forward to remove it.
- (2) Remove the transmitter from its case by loosening the 16 Allen head screws and pulling the transmitter forward by the 2 handles on the front panel.

- (3) Place wooden blocks under the transmitter so that the front panel is several inches clear of the work bench surface.
- (4) Remove the locking keys, the indicating plates, and the spring washers from the BAND SELECTOR and TUNING CONTROL knobs by turning the locking bars in a counterclockwise direction. Rotate these control knobs fully counterclockwise (to home stop position); then rotate them clockwise until the knob setscrews are accessible. Make a note of the position of these knobs as shown on the frequency indicator; then remove them by loosening setscrews with a No. 8 fluted wrench. Remove the nut and flat washer from the shaft of each control.
- (5) Remove the knob from the DIAL ZERO control by removing the Phillips screw and lockwasher. Remove the nut and flat washer from the shaft of this control.
- (6) Hold the metal strip to prevent its turning and remove the Phillips screw from the clip on top of antenna relay K614 (fig. 103). This releases the relay from WHIP ANTENNA receptacle 615.
Caution: Use paraffin on the screwdriver tip or use longnosed pliers to lift out washer and screw; this prevents dropping parts into the transmitter. Avoid undue strain on glass parts of relay K614.
- (7) Disconnect plugs P201, P205, and P206 (fig. 75) of the power-amplifier subchassis from J608 and J618 (fig. 100). Disconnect plugs P402 and P403 (fig. 85) of the modulator subchassis from J619 (fig. 103). Disconnect plug P901 (fig. 92) of the antenna-network servo amplifier from J611.
- (8) Remove the seven flathead screws (nearest the front panel) on each side plate that connect the side plates to the front panel casting.
- (9) Use a No. 10 ($\frac{5}{16}$ -inch) socket wrench and remove the nine bolts, the nine lockwashers, and the flat washers that join the front panel with the framework of the transmitter.
- (10) Run a wire or cord through the uppermost bolt hole in the center of the front

panel and loop it through the corresponding hole in the framework. Tie it in a loop several inches long.

- (11) Carefully pull the front panel straight forward until the Autotune shafts are clear; then allow it to tilt forward about 30°. Adjust the loop of wire or cord to a length which permits it to support the forward pull of the front panel.

Caution: Do not permit the internal wiring to support the weight of the front panel.

- (12) Remove the rubber O-rings located inside the bushings for the BAND SELECTOR, TUNING CONTROL, and DIAL ZERO shafts. Grease the O-ring retaining groove in the bushing with Dow Corning 33 Heavy grease. Insert a new O-ring into the bushing.
- (13) When any of the bolts penetrating the front panel are removed, grease the rubber O-ring with Dow Corning 33 Heavy grease before replacing, remove the defective O-ring from the bolt. Replace the split lockwasher, flat washer and new O-ring in that order. Grease the new O-ring with Dow Corning 33 Heavy grease before replacing the bolt in the front panel.

b. Replacement of Front Panel. To replace the front panel, proceed in the reverse order of removal. When lifting the front panel back into place after removing its temporary wire loop supports, make sure that no wires have slipped between the mating surfaces of the front panel and the framework of the transmitter. When replacing the BAND SELECTOR or TUNING CONTROL knobs, make sure that the setscrews within the knob are adjacent to the flatted portions of the shafts.

c. Removal of Master-Oscillator Subchassis. To remove the master-oscillator subchassis (fig. 5), proceed as follows:

- (1) Remove the transmitter from its case.
- (2) Remove the back plate of the transmitter by removing the 8 screws and lockwashers and the 10 flathead screws.
- (3) Rotate the TUNING CONTROL until the setscrew on the shaft gear of the mo subchassis is accessible. Make a note of this position, as shown on the frequency indicator.

Note. If the synchronization of the master-oscillator subchassis is to be maintained, do not disturb the position of the shaft during the succeeding steps or after the subchassis has been removed.

- (4) Disconnect plugs P801 and P802 (fig. 68) from J101 (fig. 71) and J617 (fig. 97), and disengage the coaxial cable (terminated in P801) from the spring clips holding it to the exciter.
- (5) Remove the regulator assembly (fig. 98) from the main frame by loosening the three green captive screws.
- (6) Remove the bracket from in front of the regulator assembly by removing the four Phillips screws and lockwashers, and slide the bracket over the cable of the regulator assembly.
- (7) Remove the two green screws that hold the tube shield of V801, and remove the tube shield. Remove tube V801.
- (8) Remove the spring-type tube shield and tube V802.
- (9) Remove the three captive screws holding the mo subassembly to the main frame.
- (10) Loosen the setscrew in the gear, being careful not to turn the shaft. Hold the gear while pulling the subchassis back about one-fourth of an inch, and then lift it out, together with the gear.
- (11) Tighten the setscrew in the gear and make an index mark on the gear and the subchassis; this will indicate the position of the shaft if it is accidentally turned.

d. Replacement of Master-Oscillator Subchassis.

To replace the mo subchassis, proceed in the reverse order of removal. If a new subchassis is to be installed, or if for any other reason the setting of the shaft of the subchassis shaft is in doubt, synchronize the shaft (par. 120).

e. Removal of Exciter Subchassis. To remove the exciter subchassis (fig. 5), proceed as follows:

- (1) Remove the transmitter from its case and remove the back plate.
- (2) Turn the PRESET CHANNELS switch to M and manually rotate (after loosening locking bars) the BAND SELECTOR and TUNING CONTROL to 3 megacycles, as indicated on the frequency indicator.
- (3) Disconnect plugs P101, P601, and P801 (figs. 71, 97, and 68) from J607 (fig. 97), J101, and J102 (fig. 71).

- (4) Loosen the four green captive screws and remove the subchassis by sliding it back; at the same time, disengage the cables of P601 and P801 from the clips on the front of the exciter.

Note. If the synchronization of the exciter subchassis is to be maintained, do not disturb the position of the two Oldham couplers (fig. 74) to which the tuning and switching shafts are connected. Mark their positions in the event they should accidentally be moved.

f. Replacement of Exciter Subchassis. To replace the exciter subchassis, proceed in the reverse order of removal. Make sure that in the 3-mc position, the holes in the tuning cams are in line with the slots. Before securing plugs P601 and P801, make sure that their cables are in place on the clips and that these cables are fed through the rectangular hole on the front of the exciter subchassis.

g. Removal and Replacement of Power-Amplifier Subchassis. To remove the power-amplifier subchassis (fig. 6), proceed as follows:

- (1) Remove the transmitter from its case and then remove the back plate.
- (2) Disconnect plugs P201, P205, and P206 (fig. 75) from J608, and J618 (fig. 100).
- (3) Loosen the four green captive screws, and remove the subchassis from the main frame.

Note. If the synchronization of the power-amplifier subchassis is to be maintained, do not disturb the position of the Oldham coupler to which the switch shaft is connected. Mark its position in the event that it should accidentally be moved.

- (4) To replace the power-amplifier subchassis, proceed in the reverse order of removal.

h. Removal and Replacement of Modulator Subchassis. To remove the modulator subchassis (fig. 6), proceed as follows:

- (1) Remove the transmitter from its case as directed above.
- (2) Disconnect plugs P401, P402, and P403 (figs. 89 and 85) from J601 and J619 (fig. 103).
- (3) Loosen the seven green captive screws, and lift the subchassis from the main frame.
- (4) To replace the modulator subchassis, proceed in the reverse order of removal.

i. Removal and Replacement of Antenna-network Servo-amplifier Subchassis. To remove the antenna-network servo-amplifier subchassis (fig. 6), proceed as follows:

- (1) Remove the transmitter from its case.
- (2) Disconnect plug P901 (fig. 92) from J611.
- (3) Loosen the two green captive screws, and lift the subchassis from the main frame.
- (4) To replace the antenna-network servo-amplifier subchassis, proceed in the reverse order of removal.

j. Removal and Replacement of Discriminator Subchassis. To remove the discriminator subchassis (fig. 5), proceed as follows:

- (1) Remove the transmitter from its case as directed above.
- (2) Disconnect plug P302 (fig. 84) from J609 (fig. 97).
- (3) Loosen the three green captive screws and lift the subchassis from the main frame.
- (4) To replace the discriminator subchassis, proceed in the reverse order of removal.

k. Removal and Replacement of Variable Inductor Subchassis. To remove the variable inductor subchassis (fig. 5), proceed as follows:

- (1) Remove the transmitter from its case and remove the back plate.
- (2) Disconnect plug P1101 (fig. 96) from J612 (fig. 97).
- (3) Loosen the four green captive screws, move the subchassis slightly backward, disengage connectors J1101 and J1102 (fig. 96) from E611 (fig. 98) and P602, and remove the subchassis.
- (4) To replace the variable inductor subchassis, proceed in the reverse order of removal.

l. Removal of Antenna Tuning Capacitor Subchassis. To remove the antenna tuning capacitor subchassis (fig. 5), proceed as follows:

- (1) Remove the transmitter from its case as directed above.
- (2) Disconnect plugs P1001 and P1002 (figs. 94 and 95) from J610 and E611 (figs. 97 and 98).
- (3) Loosen the four green-color coded captive screws and lift the subchassis from the main frame.

m. Replacement of Antenna Tuning Capacitor Subchassis. To replace the antenna tuning ca-

pacitor subchassis, proceed in the reverse order of removal. During replacement, make sure that plug P303 (fig. 84) seats properly with J1001 (fig. 94).

n. Removal of Frequency Indicator Assembly (figs. 102 and 103). To remove the frequency indicator, proceed as follows:

Note. During these procedures, do not rotate the shafts of S605, BAND SELECTOR, and the TUNING CONTROL, because synchronization may be lost.

- (1) Remove the front panel.
- (2) Note the frequency reading of the counter dial, the band setting of the band indicator, and the channel setting of the channel indicator for later reference.
- (3) Remove the mask marked CHAN. BAND by removing the three mounting screws.
- (4) Remove the band indicator disk by removing the three mounting screws.
- (5) Remove the threaded sleeve from the BAND SELECTOR shaft.
- (6) Carefully note the positioning of the shutter lever cam before proceeding with the next step.
- (7) Use a No. 10 fluted socket wrench and loosen the three setscrews on the collar which fastens the cam gear to the BAND SELECTOR shaft. Remove the collar and gear.
- (8) Loosen the setscrew which fastens the channel indicator disk to the shaft of S605. Remove the disk.
- (9) Remove the two mounting screws of the frequency dial lamp assembly, and swing the assembly away from the frequency indicator.
- (10) Remove the four screws which mount the frequency indicator to the main frame.
- (11) Carefully pull the frequency indicator assembly slightly away from the main frame and to the left, to disengage the dial corrector clutch yoke; note the position of the yoke at the back of the dial-corrector gear.

o. Replacement of Frequency-Indicator Assembly. To replace the frequency-indicator assembly, reverse the procedures of *n* above, making sure that the channel and band indicator disks, the frequency indicator, and the shutter lever cam are positioned exactly as noted during removal.

When replacement is complete, check the operation of the frequency indicator to see if the counter drum exposed is the correct one for the bands selected.

p. Removal and Replacement of Autotune Control Head. To remove the Autotune control head (fig. 103), remove the front panel and the frequency indicator. Then proceed as follows:

- (1) Note and disconnect the color-coded wires on the control head terminal board.
- (2) Remove the two slotted screws and one Phillips screw which secure the head to the casting.
- (3) Remove the control head.
- (4) To replace, proceed in the reverse order of removal.

q. Removal and Replacement of BAND SELECTOR Singleturn Head. To remove the singleturn head (fig. 103), remove the front panel and frequency indicator. Then proceed as follows:

- (1) Loosen the setscrew and free the gear attached to the driven end of the singleturn-head shaft.
- (2) Remove the two slotted-head screws and the one Phillips screw which secure the head to the casting.
- (3) Remove the singleturn head.
- (4) To replace the BAND SELECTOR singleturn head, proceed in the reverse order of removal.

r. Removal and Replacement of TUNING CONTROL Multiturn Head. To remove the multiturn head (fig. 103) remove the front panel and the frequency indicator. Then proceed as follows:

- (1) Loosen the setscrew and remove the gear attached to the other end of the multiturn-head shaft.
- (2) Remove the two slotted-head screws and the one Phillips screw which secure the head to the casting.
- (3) Remove the multiturn head.
- (4) To replace the multiturn head, proceed in the reverse order of removal.

s. Removal of Tuned Circuits (Exciter Subchassis). To remove a tuned circuit (Z101 through Z110, fig. 74), proceed as follows:

- (1) Remove the exciter subchassis.
- (2) Remove the two slug rack retaining springs (one at each end of the rack) and lift the slug rack from the subchassis.

Place the slug rack to one side, taking care not to bend the wire mounting or change the positioning of the tuning cores.

- (3) Remove the four mounting screws which fasten the terminal board to the subchassis; turn the terminal board back, so that the soldered connections of the tuned circuits are accessible.
- (4) Unsolder the leads to the tuned circuit being replaced; tag the leads, and mark the location on the subchassis.
- (5) Remove the two nuts and lockwashers at the bottom of the tuned circuit below the deck and remove the tuned circuit.

t. Replacement of Tuned Circuits. To replace the tuned circuits, proceed in the reverse order of removal. Aline the tuned circuits of the exciter (par. 118).

u. Removal of Motors and Dynamotors.

- (1) *Low-voltage dynamotor D601.* To remove dynamotor D601 (fig. 100), remove the power amplifier, the antenna network servo-amplifier, and the variable inductor subchassis. Then proceed as follows:

(a) Disconnect the following five color-coded leads, which are soldered to terminal board E602 (fig. 98): the white lead from terminal 1, the red lead from terminal 2, the blue lead from terminal 3, the green lead from terminal 4, and the black lead from terminal 5. Make sure that these leads are those coming from the dynamotor and not the leads going out to other parts of the equipment.

(b) Remove the three Phillips-head screws, remove the mounting bracket, and then carefully remove the dynamotor from the main frame.

- (2) *High-voltage dynamotor D602.* To remove dynamotor D602 (fig. 100), remove the back plate and the variable inductor subchassis, and then proceed as follows:

(a) Disconnect the following three color-coded leads, which are soldered to the back of terminal board E603 (fig. 97): the white lead from terminal 3, the black lead from terminal 4, and the red lead from terminal 2. Make sure that these leads are those coming from

the dynamotor and not the leads going out to other parts of the equipment.

- (b) Remove the eight Phillips-head screws, remove the mounting bracket, and carefully remove the dynamotor from the main frame.
- (3) *Autotune motor B601.* To remove Autotune motor B601 (fig. 103), remove the front panel, the frequency indicator subchassis, and the exciter subchassis. Remove the end plate next to B601 by taking out the 23 flathead screws. Then proceed as follows:
 - (a) Unsolder the following six color-coded leads from the terminal board of the motor: the white lead with black and red tracers from terminal A1, the white lead with black and orange tracers from terminal A2, the white lead and the green leads from terminal F1, and the white lead and the black lead from terminal F2. Tag the leads to prevent wiring mistakes.
 - (b) Unfasten relay K610 (fig. 103) from the main frame by removing the two screws. Do not unsolder any leads from the relay; carefully swing the relay to one side to permit removal of the motor, described in (c) below.
 - (c) Remove the three screws which hold the motor to the main frame.

Note. To gain access to the bottom screw, it may be necessary to turn the TUNING CONTROL; this uncovers the screw by exposing it through one of the holes in the gear which is driven by the motor pinion gear. If this has to be done, observe the reading on the frequency indicator before changing the gear position. Make sure that the frequency indicator is returned to its original setting before replacing the exciter subchassis.

- (4) *Blower motor B602.* To remove motor B602 (fig. 103), remove the front panel as follows:
 - (a) Note and tag the three leads from the terminal board on the blower assembly, and then remove them.
 - (b) Dismount the blower assembly from the main frame by removing the four screws and lockwashers.
 - (c) Note, tag, and disconnect the motor brush leads.

- (d) Note the locations and positions of the left- and right-hand housings of the blower assembly. Dismount each housing by taking out the three screws together with baffle plate.
- (e) Note the locations of the left- and right-hand fans, and remove the fans by loosening the setscrews in their respective hubs.
- (5) *Output capacitor motor B603.* To remove motor B603 (fig. 97), remove the front panel and the variable inductor subchassis, and proceed as follows:
 - (a) Note and tag the wiring to the motor, and disconnect the leads from the top and bottom terminal connections by removing the screw at each connection. Replace the screws after disconnecting the leads.

Note. A dental-type mirror is useful as an aid in disconnecting the wiring from the bottom terminal connection.

- (b) Dismount the motor by taking out the two flathead screws which hold the motor to the main frame.
- (6) *Blower motor B202.* To remove blower motor B202 (fig. 75), remove the power amplifier subchassis and proceed as follows:
 - (a) Remove the four screws holding the blower housing to the power amplifier subchassis. Remove the blower housing and expose the blower fan (figure 78).
 - (b) Unsolder the lead from R239. This is the wire wound resistor mounted on the blower mounting plate with the blower. The wire to be unsoldered is connected to the end of the resistor which is farthest from the mounting plate.
 - (c) Remove the two screws from the blower mounting plate.
 - (d) Grasp the fan and gently lift the assembly out of the hole.

Caution: Do not force.

- (7) *Homing motor B1102.* To remove homing motor B1102 (fig. 96), remove the variable inductor subchassis and proceed as follows:
 - (a) Note and tag the wiring to the motor, and disconnect the leads from the ter-

minal connections by removing the screw at each connection. Replace the screws after disconnecting the leads.

- (b) Dismount the motor by taking out the two flathead screws which hold the motor to the main frame.

v. Replacement of Motors and Dynamotors. To replace any of the motors or dynamotors in Radio Transmitter T-195/GRC-19, proceed in the reverse order of removal.

w. Removal and Replacement of Brushes. Low-voltage dynamotor D601 has four sets of brushes, and the high-voltage dynamotor has two sets of brushes. Of the eight motors in the transmitter, servo motors B201, B1001, and B1101 do not have brushes. Brushes in both dynamotors should be examined after every 250 hours of operation, and should be replaced when the overall length of the brush is less than 50 percent of the overall length of a new brush. Dynamotors D601 and D602 should be lubricated (par. 110c) during the removal of their brushes for normal inspection. Except where indicated, the replacement procedure for the brushes is the reverse of the removal procedure described below.

Caution: Before replacing brushes, carefully blow all carbon dust and dirt from the commutator and other motor parts. Do not attempt to remove the discoloration (not to be confused with dirty or pitted commutators) from the commutators, since this is a copper oxide. Install brushes that are polarized (stamped with a positive or negative marking) in brush holders which are similarly marked; install them so that the curved face of the brush fits the curved surface of the commutator. To avoid loss in output voltage, fit the high-voltage brushes of the dynamotor with exceptional care. When brushes with helical springs are employed, install the brush caps with care, so that the springs are not distorted. Observe the standard Signal Corps instructions, MIL-D-24, for correct seating and running-in procedures.

- (1) *Low-voltage dynamotor D601.* To remove the brushes in dynamotor D601, remove the dynamotor, but do not unsolder the leads.

- (a) Remove the two brush covers by removing the four screws in each cover. Pull the covers off, exposing the three sets of brushes. The speed regulator brushes are on one end, and the +250-

volt and the -451-volt brushes are on the other end.

Note. If the brushes are removed after 250 hours of operation, lubricate the bearings (par. 110c).

- (b) Remove the perforated band around the middle of the dynamotor by removing the six screws, thereby exposing the set of 24-volt brushes.
 - (c) Remove and inspect each set of brushes. Replace each set of brushes before removal and inspection of the next set. To remove a brush, unfasten the insulated cap screw, thereby releasing the spring and its brush.
- (2) *High-voltage dynamotor D601.* To remove the brushes in dynamotor D602, first remove the dynamotor but do not unsolder the leads.
 - (a) Remove the two brush covers, one on each end of the dynamotor, by removing the three screws in each cover. Pull the covers off, exposing the +28-volt-input brush set on one end, and the +1,000-volt-output brush set on the other end.

Note. If the brushes are removed after 250 hours of operating, lubricate the bearings (par. 110c).

- (b) Remove and inspect each set of brushes. Replace each set of brushes before removal and inspection of the next set. To remove a brush, unfasten the insulated cap screw, thereby releasing the spring and its brush.
- (3) *Autotune motor B601.* To remove the brushes in motor B601, first remove the motor, but do not unsolder the leads. To remove each of the two brushes, release the retainer clip, thereby freeing the brush-holder cap.
 - (4) *Blower motor B602.* To remove the brushes in motor B602, first remove the motor, but do not unsolder the leads. To remove each of the two brushes, unfasten the brush-holder cap.
 - (5) *Output capacitor motor B603.* To remove the brushes in motor B603, remove the motor.
 - (a) Remove the cover from the end of the motor to make the brush assembly accessible.

- (b) Remove the top brush by lifting up the spring with a pair of long-nosed pliers, and pulling the brush out of its holder. Free the brush lead from the terminal connection by removing the screw.
- (c) Using a dental-type mirror, remove the bottom brush by repeating the procedure of (b) above.
- (6) *Blower motor B202.* To remove and replace the brushes in motor B202, remove the motor and proceed as follows:
 - (a) Remove the screw and slide the cylindrical cover from the shaft end of the motor.
 - (b) Unsolder the two brush leads from their respective terminal connections.
 - (c) Note the position of the brush housing (opposite to shaft end) in regard to the polarity, and remove the housing by taking out the two screws.
 - (d) Remove the brush springs, and take out the brushes.
 - (e) When replacing the brushes, solder the brush leads to their respective terminals.
 - (f) Observing the position noted in (c) above, replace the brush cover, and secure it with the two screws.

Note. Turn the shaft to make sure that the armature rotates freely.
 - (g) Insert each brush in place, and install the spring in the slot in the brush.
 - (h) Wrap transparent tape around the brush housing.
 - (i) Replace the cylindrical cover, and secure the cover with the screw.
- (7) *Homing motor B1102.* To remove the brushes in motor B1102, remove the motor but do not unsolder the leads. To provide more play in the wiring, remove the cable clamp which secures the cable of plug P1101. The removal and replacement of the brushes in motor B1101 are identical with the procedures given for blower motor B202.

r. Removal and Replacement of Lamps. To remove dial lamp I 601 (fig. 102) from behind the band-channel indicator, remove the six screws, and take off the window and its gasket. The bayonet-type lamp is removed by turning it in a counterclockwise direction. To remove dial lamps

I 602 and I 603 (fig. 102) from behind the frequency indicator, remove the twelve screws and take off the window and its gasket. These lamps are removed in the same way as for I 601. A spare lamp (fig. 5) is located on the transmitter framework. To obtain access to this lamp, loosen the sixteen wing nuts on the front panel and pull the transmitter partly out of its case. When replacing the windows of the band-channel indicator and/or frequency indicator, make sure that gasket shellac is first applied to the gaskets to make the windows watertight. To replace TUNING INDICATOR lamp I 605 (fig. 102), turn the jewel in a counterclockwise direction and remove the lamp in the same manner as for I 601.

y. Variable Inductor Ribbon Replacement (fig. 112). If the silver ribbon of the variable inductor should break or become defective in any way, replace it as follows:

- (1) Remove the variable inductor subchassis from the main frame.
- (2) Remove the retaining ring of gear 3, and remove the gear.
- (3) Unsolder the ribbon connections from the terminal on the ceramic coil form and the brass shorting drum. Remove all solder from the coil form and drum terminals.
- (4) Solder the end of the replacement ribbon (1) to the terminal of the ceramic coil form (2) (C, fig. 112).
- (5) Wind 30 turns of ribbon tightly onto the coil form, taking care not to kink or bend the ribbon. Secure the end of the ribbon to the form with tape. Do not cut off the excess length.
- (6) Viewing the assembly (B, fig. 112), rotate the shorting drum (12) clockwise to the stop, and rotate the coil form so that the arm (6) is positioned as shown.
- (7) Remove the tape which holds the free end of the ribbon to the coil form, and thread the ribbon through the slots (7) of the shorting drum (B, fig. 112).
- (8) Make sure that all turns of the ribbon are tight on the coil form, and that the coil and drum are properly positioned; then bend the end of the ribbon back over the slots. Cut off the excess length of ribbon and solder the end of the ribbon to the terminal.

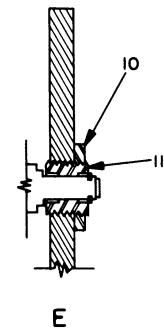
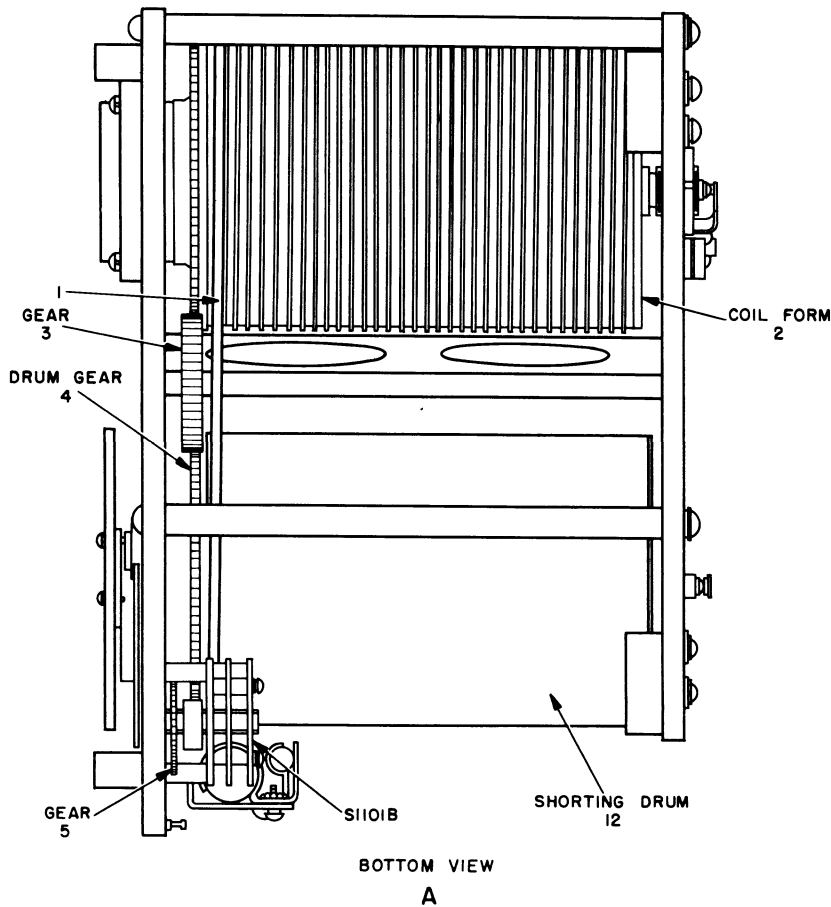
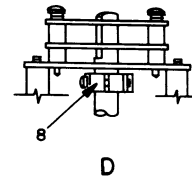
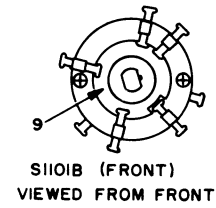
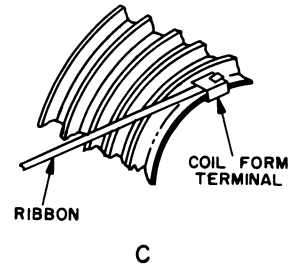
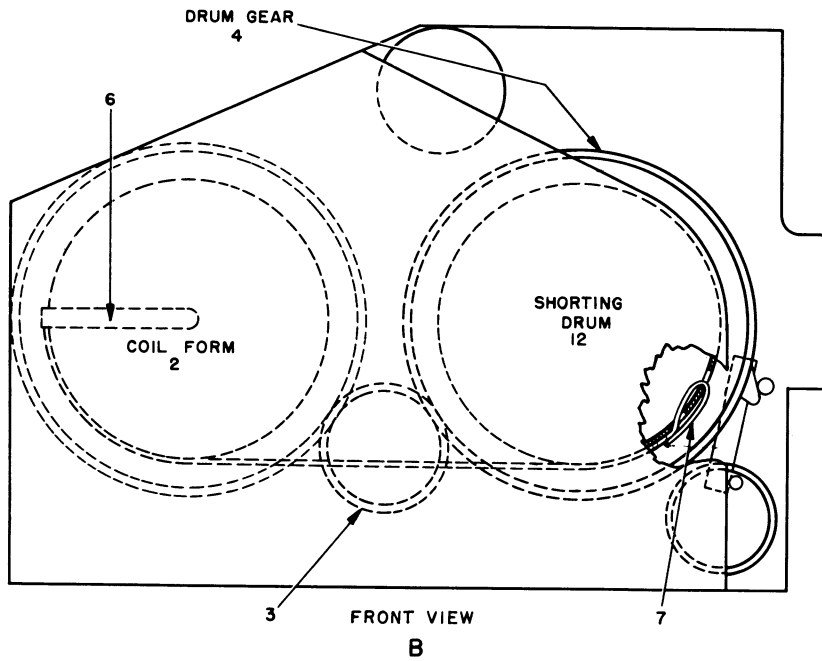

Figure 112. Variable inductor ribbon replacement.

TM 806 -120

- (9) Hold the coil form and the shorting drum in position; rotate the drum gear (4) in a counterclockwise direction, against the tension of the spring and for a distance of approximately ten gear teeth. Slip gear 3 into position with the flush side of the bearing toward the retaining ring.
- (10) Rotate the coil form and the shorting drum counterclockwise to the stop; hold the coil form and the shorting drum in position and perform the following steps:
 - (a) Remove gear 3.
 - (b) Rotate gear 4 counterclockwise, against the tension of the spring, to the stop. Allow gear 4 to rotate in a clockwise direction for a distance of three gear teeth; then place gear 3 back in position.

Note. Check the tension of the ribbon between the coil form and the drum. If the ribbon is slack or too taut, repeat the procedure of (10) above.

- (11) Rotate the coil form and the drum clockwise to the stop; then reverse the direction one complete turn (360°). The rotor (9) of switch S1101A (front) should be positioned as shown in D, figure 112. If it is not, loosen the clamp (8) and rotate the rotor until it is positioned properly. Do not allow gear 5 (A, fig. 112) to move during this step. When the switch has been adjusted, tighten the clamp.

Note. It is unlikely that the alignment of the coil form and the drum will be disturbed during the above procedure. However, if the ribbon does not seat properly between the ribs of the coil form during winding, the coil form can be adjusted. Loosen the locking nut (10) (fig. 112E) and adjust the bushing (11) so that ribbon tracking is satisfactory. Tighten the locking nut and transfer the ribbon between the coil form and the shorting drum four times. If ribbon tracking remains satisfactory, secure the locking nut with glyptal.

- (12) Reinstall the variable inductor subchassis into the main frame.

109. Disassembly and Reassembly of Autotune Mechanism

Note. Only those organizations authorized to disassemble the multiturn positioning head should do so.

a. Disassembly of Band Selector Singleturn Head. The index numbers (in the following pro-

cedure) correspond with those assigned to the exploded view of the singleturn head (fig. 113).

- (1) Remove the eight Phillips screws (1) and free the right dust cover (2) and left dust cover (3).
- (2) Remove the locking key (4).
- (3) Remove the wire from the heads of the two spring anchor screws (5); loosen, but do not remove these screws.
- (4) Remove the camshaft nut (6) and the No. 10 lockwasher (7).
- (5) Remove the four Phillips screws (8) and the four Shakeproof washers (9) from the front-plate assembly (10); remove the assembly and springs.
- (6) Remove the two Phillips screws (11), the two lockwashers (12), and the lower-plate standoff (13).
- (7) Remove the two Phillips screws (14), the two lockwashers (15), and the upper standoff assembly (16).
- (8) Remove the retaining ring (17), retaining ring washer (18), and shims (19) from the camshaft (20).
- (9) Remove the pawl-shaft nut (21) and Shakeproof washer (22) from the spring-pawl assembly (23).
- (10) Remove the camshaft (20), spring-pawl assembly (23), and stop-ring shaft assembly (24) from the rear-plate assembly (25).

b. Reassembly of Band Selector Singleturn Head. The index numbers are the same as those used in the disassembly procedure (fig. 113).

- (1) Assemble the upper standoff assembly (16), using the two Phillips screws (14) and lockwashers (15).
- (2) Assemble the low-plate standoff (13) to the rear-plate assembly (25), using the two Phillips screws (11) and Shakeproof washers (12).
- (3) Lubricate the rear ball-bearing assembly (item 24) and the ball-bearing race (25) with Grease, Aircraft and Instruments (GL) MIL-C-3278 or an equivalent, then insert item 24 into item 25.
- (4) Screw the spring-pawl assembly (23) into the rear-plate assembly (25).
- (5) Insert the two spring anchor screws (5) through the holes in the lower-plate standoff (13), and rotate the screws two turns into the spring anchors.

- (6) Remove all the parts from the camshaft (20) and apply a thin film of grease (GL) or an equivalent, to the entire shaft. Replace all the parts and insert the camshaft in the rear-plate assembly (25).
 - (7) Lubricate the front ball-bearing retainer assembly (item 24) and the ball-bearing race (located in item 10) with grease (GL) or an equivalent. Replace and secure item 10 to the lower-plate standoff (13), using the four Phillips screws (8) and Shakeproof washers (9).
 - (8) Put the retaining-ring washer (18) and retaining ring (17) on the camshaft (20). Put as many shims (19) as required under item 18 for .002 to .004-inch end play on the camshaft (20).
 - (9) Put a No. 10 lockwasher (7) and the camshaft nut (6) on the camshaft (20). Handtighten the camshaft nut.
 - (10) Rotate the shaft of spring-pawl assembly (23) so that the pawls align in the approximate center of the cams on the camshaft (20).
 - (11) Put the Shakeproof washer (22) and pawl-shaft nut (21) on the spring pawl assembly. Do not tighten the nut (21).
 - (12) Tighten the spring anchor screws (5), and secure them with safety wire.
 - (13) Adjust the singleturn head as directed in paragraph 114.
 - (14) Lubricate the head (fig. 117).
 - (15) Coat the threads of the locking key (4) with grease (GL), and insert the key in item 24.
 - (16) Replace and secure the left dust cover (3) and the right dust cover (2), using eight Phillips screws (1).
- c. Disassembly of Tuning Control Multiturn Head.* The index numbers used in the following procedure correspond with those assigned to the exploded view of the multiturn head (fig. 114).
- (1) Remove the two Phillips screws (1) and the Shakeproof washers (2).
 - (2) Remove the twelve Phillips screws (3) that secure the right dust cover (4), the left dust cover (5), and the top dust cover (6).
 - (3) Remove the locking key (7).
 - (4) Remove the cam-drum nut (8) and the lockwasher (9). Insert a No. 10 Bristo wrench in the Bristo socket in the end of the shaft to prevent the shaft from rotating. (This is a left-hand thread.)
 - (5) Remove the safety wires (10) from the four spring anchor screws (11), and remove the screws.
 - (6) Remove the five Phillips screws (12) and the five Shakeproof washers (13).
 - (7) Carefully remove the front-plate assembly (14).
 - (8) Remove the front ball-bearing assembly (15), the felt washer (16), and the home-stop actuator gear assembly (17).
 - (9) Remove the felt oiler (18) and the camshaft sleeve (19).
 - (10) Remove the four Phillips screws (20), the four lock washers (21), the upper-right standoff assembly (22), and the upper-left standoff assembly (23).
 - (11) If the pawls are not in the lifted position, insert a screwdriver into the slot in the front end of the pawl-lifter assembly shaft (24), and turn the shaft clockwise so that the mechanism is actuated and the pawls are lifted.
 - (12) Remove the cam-drum assembly (25).
 - (13) Remove the pawl-shaft nuts (26), the Shakeproof washers (27), and the retaining rings (28).
 - (14) Remove the stop-ring shaft assembly (29), and carefully lay aside the rear ball-bearing assembly (30).
 - (15) Remove the three Phillips screws (31) and the three lockwashers (32) which hold the lower-plate standoff assembly (33) to the rear-plate assembly. Remove the lower-plate standoff assembly.
 - (16) Remove the retaining ring (34), the retaining-ring washers (35), and all the shims (36) under the retaining-ring washers. The camshaft (37) and ratchet-pawl assembly (38) may then be removed from the rear-plate assembly.
 - (17) Disengage the toggle spring (39) (which holds the pawl-lifter assembly (40) to the rear-plate assembly) from the post (41).
 - (18) Remove the worm-shaft assembly (42); then remove the worm-gear assembly (43) from the worm-shaft assembly.
 - (19) Use a No. 10 Bristo wrench and unscrew both pawl shafts, a little at a time, until the shaft assemblies (44 and 45),

the home-stop mechanism (consisting of items 47, 48, 49, 50, 51, 52, 53), and the counter-drum (46) can be removed. If the shaft assemblies (44 and 45), and the home-stop mechanism, are to be disassembled, proceed as directed in (20) below; if they are not to be disassembled, proceed as directed in (25) below.

- (20) Disengage the stop-ring pawl heels from the counter-drum pawl tails.
- (21) Remove the stop-anchor assembly (47) from the counter-drum pawl shaft (44).
- (22) Loosen the setscrew (48) on the stop-anchor assembly (47) to remove the push rod (49).
- (23) Disengage the push-rod from the home-stop pawl (50) by removing the retaining wire (51) and the push-rod spacer (52).
- (24) Free the stop-return spring (53) from the stop-anchor assembly (47).
- (25) Remove the shim (54), the cam-drive-gear assembly (55), and the felt washer (56) from the counter-drum assembly (46).
- (26) To disengage the toggle spring (57) from the pawl-lifter assembly and remove the pawl-lifter assembly (40) from the rear-plate assembly, remove the snap-ring (58) at the rear of the pawl-lifter assembly shaft (24).
- (27) Remove the snap-rings (59) from the post (60) and remove the toggle spring (57).
- (28) Use a No. 6 Bristo wrench and loosen the screws (61) and remove the pawl-lifter assembly shaft (24) from the pawl-lifter assembly (41).

d. Reassembly of Tuning Control Multiturn Head. The index numbers are the same as those used in the disassembly procedure (fig. 114).

- (1) Use a No. 6 Bristo wrench and attach the pawl-lifter assembly (40) to the pawl-lifter assembly shaft (24). Tighten the setscrews (61).
- (2) Replace the toggle spring (57) on the post (60) and replace the snap-ring (59).
- (3) Replace the pawl-lifter assembly (40); then replace the snap-ring (58).

Note. If the home-stop mechanism has been disassembled, proceed as directed in (4) below; if it has not been disassembled, proceed as directed in (9) below.

- (4) Attach the stop-return spring (53) to the stop-anchor assembly (47).
- (5) Engage the push-rod (49) with the home-stop pawl (50). Replace the push-rod spacer (52) and the retaining wire (51).
- (6) Insert the push-rod (49) in the stop-anchor assembly (47) and tighten the set-screw (48).
- (7) Attach the stop-anchor assembly (47) to the counter-drum pawl shaft.
- (8) Engage the stop-ring pawl heels with counter-drum pawl tails.
- (9) Replace the shim (54), the cam-drive-gear assembly (55), and the felt washer (56) on the counter-drum assembly (46).
- (10) Replace the shaft assemblies (44 and 45) (with home-stop mechanism in position) and the counter-drum (46) on the rear-plate assembly simultaneously. Use a No. 10 Bristo wrench and turn the Bristo sockets in the ends of the shafts a little at a time, until the counter-drum pawls are aligned with the counter-drum rings.
- (11) Re-engage the toggle spring (39) with the post (41).
- (12) Replace the ratchet-pawl (38) on the camshaft (37), and reposition the assembly on the rear-plate assembly. Replace the shims (36), the retaining washer (35), and the retaining ring (34), all of which are associated only with the camshaft assembly.
- (13) Replace the worm-gear assembly (43) on the worm-shaft assembly (42).
- (14) Replace the worm-shaft assembly on the rear panel. Replace the retaining ring (28).
- (15) Replace the shims (36), the retaining-ring washers (35), and the retaining ring (34), all of which are associated only with the counter-drum assembly (46).
- (16) Replace the lower-plate standoff assembly (33). Replace the lockwashers (32) and the Phillips screws (31), all of which secure the standoff assembly to the rear-plate assembly. Make sure that both ends of the spring (53) are positioned in the holes (62) of the lower-plate standoff assembly.

- (17) Reattach the rear ball-bearing assembly (30) on the stop-ring shaft assembly (29). Position the stop-ring shaft in place on the rear-plate assembly.
- (18) Replace the washers (27) and the pawl-shaft nuts (26); handtighten only.
- (19) Replace the cam-drum assembly (25).
- (20) Replace the upper-right standoff assembly (22) in position on the rear-plate assembly. Make sure that the counter drum (46) is in a position to insure that the post (on ring gear) will fall between the stops (63) on the standoff assembly.
- (21) Replace the camshaft sleeve (19) and the felt oiler (18).
- (22) Replace the home-stop actuator gear assembly (17), the felt washer (16), and the front ball-bearing assembly (15).
- (23) Replace the front-plate assembly (14).
- (24) Replace the five Shakeproof washers (13) and the five Phillips screws (12).
- (25) Adjust the position of the pawl stacks until the pawls line up with their respective rings.
- (26) Tighten all of the spring-anchor screws (11). Use a 2-inch length of No. 22 wire (10) for each set of screws and make a figure "8" loop through the heads of the screws; twist the ends of the wire together.
- (27) Replace the camshaft nut (8) (fingertight) and its lockwasher (9). Tighten the nut while holding the camshaft in position with the Bristo wrench. (This is a left-hand thread).
- (28) Replace the locking key (7).
- (29) Replace the two washers (2) and all of the Phillips screws (1).
- (30) Synchronize the home-stop mechanism by placing the TUNING CONTROL knob on the multiturn shaft and tightening its setscrews. Replace the locking key, but do not lock. Use a screwdriver and rotate the pawl-lifter shaft (24) clockwise. Rotate the stop-ring shaft clockwise until the home-stop pawl begins to rotate. Stop the rotation before the home-stop pawl has been fully actuated. With a Bristo wrench, loosen the setscrews in the idler gear on the worm-shaft assembly (42). Push this gear back and out of mesh with the drive gear on the

stop-ring shaft assembly. Rotate the counter-drum assembly clockwise until the home-stop pawl just contacts the home-stop ring. Rotate the stop-ring shaft clockwise so that the tap on the home-stop ring just contacts the toe of the home-stop pawl. Mesh the idler gear assembly with the drive gear and tighten the setscrews.

- (31) Check the adjustment by rotating the stop-ring shaft to the counterclockwise home-stop position. The toe of the home-stop pawl should fully engage the tab on the home-stop ring. Rotate the stop-ring shaft fully clockwise and then counterclockwise again to check for the same condition. If the adjustment is incorrect, repeat the entire procedure.
- (32) Rotate the multiturn shaft counterclockwise until the home-stop is actuated. Now rotate the shaft clockwise until the home-stop is actuated again, while observing whether the slots in any counter-drum rings fail to pass beneath their respective counter-drum pawl toes. With a pointed tool, rotate any misaligned rings about $\frac{1}{4}$ turn counterclockwise. Apply pressure, and be careful not to score the ring.
- (33) Lubricate the multiturn head as directed in paragraph 110.
- (34) Replace the right dust cover (4), the left dust cover (5), and the top dust cover (6), using 12 Phillips screws (3).

e. Disassembly of Autotune Control Head.

After the control head has been removed from the main frame, refer to figure 115 and accomplish the following disassembly procedure. The index numbers used in the procedure described in (1) through (23) below correspond to those assigned to the parts in the figure.

Note. Only those organizations authorized to disassemble the Autotune control head should do so.

- (1) Remove the eight Phillips screws (1); then remove the right dust cover (2) and the left dust cover (3).
- (2) Loosen the setscrew (4) and pull the channel indicator (5) off its shaft.
- (3) Remove the three Phillips screws (6) and separate the terminal board (7) from the control head.

- (4) Remove the Phillips screw (8) and pull the seeking switch (9) forward off its shaft. Do not unsolder any wires at this time unless necessary for repair.
- (5) Remove the two Phillips screws (10) and Shakeproof washers (11), the two studs (12) and lockwashers (13).
- (6) Carefully pull the front plate (14) forward until it is disengaged from the main shaft.
- (7) Unscrew the nut (15) and then pull the lug (16) off the end of the screw.
- (8) Unsolder and tag all of the wires connected to the terminals of the breaker switch (17), the reverse switch (18), and the limit switch (19).

Note.—Do not unsolder the wires from seeking switch or the terminal board unless they need repair.

- (9) Remove the two Phillips screws (20) and the two lockwashers (21), and separate the breaker switch (17) from the front plate (14).
- (10) Remove the two screws (22), and separate the top casting (23) from the rear plate (24).
- (11) Remove the two retaining rings (25 and 26) from the end of the main shaft (27) and the bearing (28).
- (12) Disengage the main shaft (27), with its attached parts, from the rear plate (24).
- (13) Loosen the set screw (29) and slide the cam (30) off the main shaft (27).
- (14) Slide the ratchet-and-gear assembly (31) off the main shaft (27).
- (15) Slide the bearing (28) out of the ratchet-and-gear assembly.
- (16) Remove the retaining ring (32) from the groove in the main shaft (27).
- (17) Slide the bushing (33), with its attached parts, off the main shaft (27).
- (18) Remove the retaining ring (34) from the bushing (33).
- (19) Slip the shims (35), the spring washer (36), the special washer (37), the spacer (38), and the actuator arm (39) off the bushing (33).
- (20) Slide the lost-motion washers (40) off the main shaft (47).
- (21) Remove the two screws (41) and separate the rear plate (24) from the bottom casting (42).
- (22) Remove the two Phillips screws (43) and the Shakeproof washers (44), and separate the bracket (45) from the bottom casting.
- (23) Remove the four Phillips screws (46) and the lock washers (47), and separate the reverse switch (18) and the limit switch (19) from the bracket (45).

f. Reassembly of Autotune Control Head.

After this control head has been disassembled, repaired, and cleaned, refer to figure 115 for the reassembly procedure that follows. The index numbers assigned to parts in the procedure in (1) through (24) below are identical with those used during the disassembly procedure (fig. 115).

- (1) Properly position the reverse switch (18) and the limit switch (19) on the bracket (45). Secure these two switches to the bracket; use the four Phillips screws (46) and four lockwashers (47).
- (2) Secure the bracket (45) to the bottom casting (42); use the two Phillips screws (43) and two Shakeproof washers (44).
- (3) Attach the rear plate (24) to the bottom casting (42); use the two screws (41).
- (4) Slide the lost-motion washers (40) onto the main shaft (27).
- (5) Slide the actuator arm (39), the spacer (38), the special washer (36), and the shims (35) onto the bushing (33).
- (6) Insert the retaining ring (34) into its slot in the bushing (33).
- (7) Slide the bushing (33), with its attached parts, onto the main shaft (27).
- (8) Insert the retaining ring (32) into its slot in the main shaft (27).
- (9) Slide the bearing (28) into the ratchet-and-gear assembly (31).
- (10) Slide the ratchet-and-gear assembly (31) onto the main shaft (27).
- (11) Slide the cam (30) onto the main shaft (27) and secure with the setscrews (29).
- (12) Insert the end of the main shaft (27) and the bearing (28) properly into their holes in the rear plate (24), and secure them in position with the retaining rings (25 and 26).
- (13) Properly position the top casting (23) and secure it to the rear plate (24) with the two screws (22).

- (14) Properly position the breaker switch (17) on the front plate (14), and secure with the two Phillips screws (20) and the two lockwashers (21).
- (15) Properly solder all removed wires to the terminals of the breaker switch (17), the reverse switch (18), and the limit switch (19). Make sure that as each wire is replaced, it corresponds to the terminal from which it was removed, as tagged upon removal.
- (16) Replace the lug (16) on end of the screw, and secure with the nut (15).
- (17) Replace the front plate (14), engaging the bearing in the front plate with the main shaft (27), and secure with the two studs (12), the two Shakeproof washers (13), the two Phillips screws (10), and the two lockwashers (11). Make certain that the rubber grommet (48) with the contained cabling is properly inserted into its slot in the front plate.
- (18) Carefully slide the seeking switch (9) onto the main shaft (27), and secure it to the front plate (14) with one Phillips screw (8).
- (19) Properly position the terminal board (7) and secure in place with the three Phillips screws (6).
- (20) Slide the channel indicator (5) onto the main shaft (27) and secure with the set-screw (4).
- (21) Rotate the main shaft (27), using the gear of the ratchet assembly (31). All of the parts, with the exception of the slip-clutch action of the actuator arm, should rotate freely without binding. While rotating the main shaft, make sure that the breaker switch (17) snaps open simultaneously with an open position on the seeking switch (9). It may be necessary to temporarily loosen the setscrews (29) and reposition the cam (30) on its shaft. Make sure that the lost-motion washers (40) become effective between limits approximately $2\frac{1}{4}$ revolutions of the spur gear.
- (22) Lubricate the control head as directed in paragraph 114.

- (23) Replace the left dust cover (3) and secure with the four Phillips screws (1).
- (24) Replace the right dust cover (2) and secure with the four Phillips screws (1).

g. Disassembly of Autotune Motor (fig. 116). After the Autotune motor has been removed, disassemble as follows:

- (1) Drive out the taper pin (1) and remove the spur gear (2).
- (2) Remove the two retainer clips (3), the brush-holder caps (4), and the brushes (5).
- (3) Remove the two frame screws (6), the two lockwashers (7), and the front housing (8).
- (4) Feed the field leads (9) through the hole in the rear housing (10) and remove the frame-and-field assembly (11).
- (5) Pull the armature (12) from the rear housing (10) and remove the bearings (13 and 14).
- (6) Remove the two screws (15) and the two lockwashers (16); then remove the filter cover (17).

h. Reassembly of Autotune Motor.

- (1) Wearing rubber gloves, remove the pre-lubricated bearings (13 and 14) from their packages, and press them on the shaft of the armature (12).
- (2) Insert the armature assembly into the rear housing (10), making sure that the bearing (14) is properly seated.
- (3) Feed the field leads (9) through the hole in the rear housing (10) and place the frame-and-field assembly (11) in position.
- (4) Replace the front housing (8) in position and secure with the two frame screws (6) and the lockwashers (7).
- (5) Insert the two brushes (5), the brush-holder caps (4), and the retainer clips (3). Observe standard Signal Corps instructions for correct seating and running-in procedures.
- (6) Place the spur gear (2) on the end of the shaft (hub inward) and secure with the tapered pin (1).
- (7) Replace and secure the filter cover (17), using the two screws (15) and the two lockwashers (16).

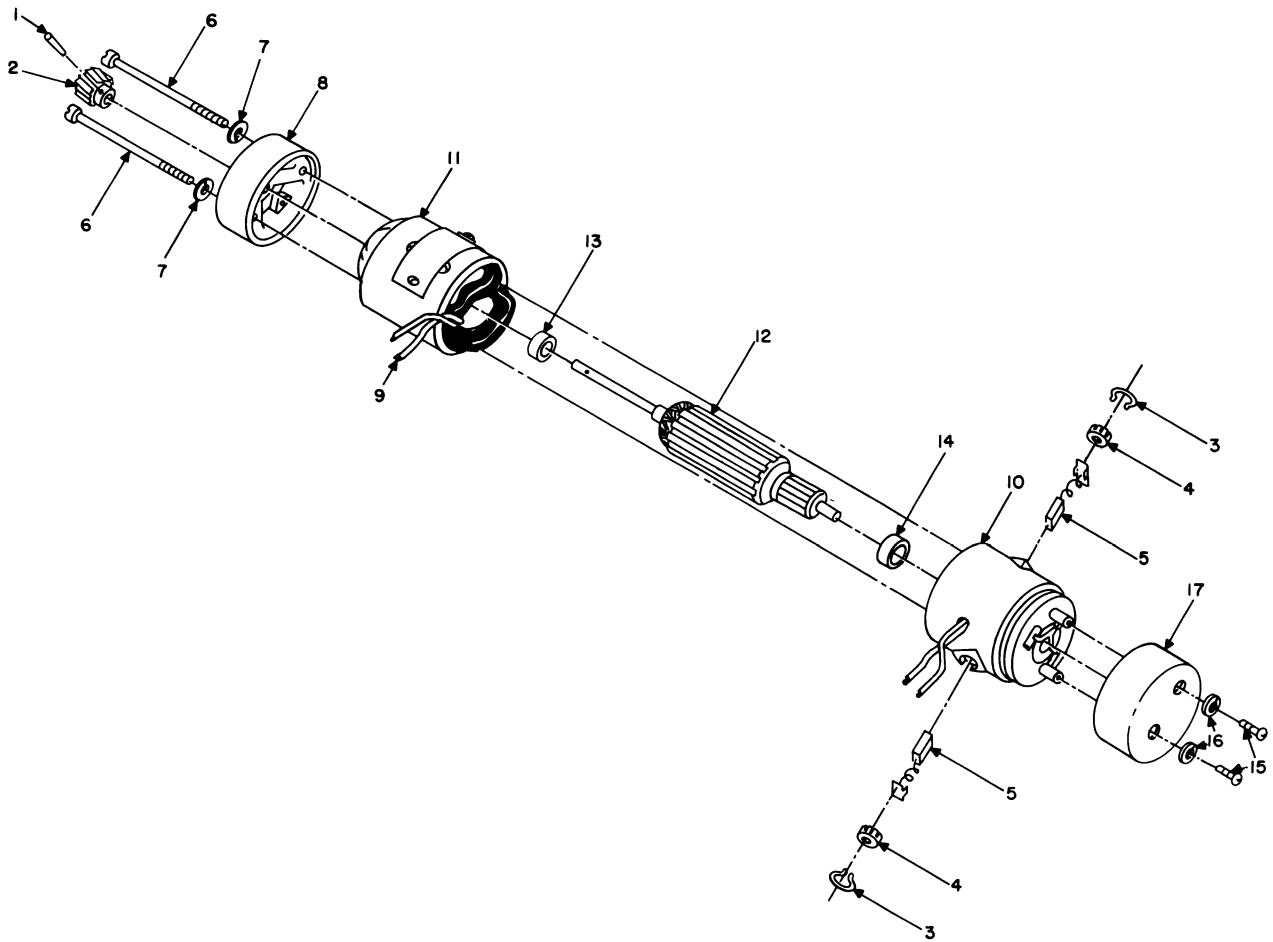

Figure 116. Disassembly of Autotune motor.

TM 806-118

110. Lubrication

The only items of the transmitter that require lubrication are the frequency indicator (fig. 122), the Autotune mechanism (figs. 117-121), the gear train in the main frame, the gears in the antenna tuning capacitor subchassis (fig. 95), the variable inductor subchassis (fig. 96), the power-amplifier subchassis (fig. 75), the slug-rack system in the exciter subchassis (fig. 74), and the dynamotors. The transmitter is lubricated initially at the factory and should be lubricated thereafter once every 6 months under normal operating conditions. The lubrication interval should be shortened only if inspection indicates the need, or if abnormal conditions are encountered. When the equipment is operated in a hot, arid climate, it may be necessary to lubricate the oillite bearings about twice as often as indicated. Overlubrication can often cause more harm than no lubrication. Inspect the me-

chanical tuning system whenever the transmitter is withdrawn from the case for servicing. Rotate the TUNING CONTROL and BAND SELECTOR controls manually throughout their ranges, noting ease of operation. Check for lack of lubrication on gears, edges of cams, cam followers, cam-follower guide slots, and bearings; inspect for gritty grease and oil. While operating the transmitter, check for excessively noisy or irregular Autotune and automatic tuning (servo system) operation.

Caution: Never attempt to lubricate the master-oscillator subchassis during turning. Unstable operation of the oscillator may result.

a. Cleaning Before Lubrication. Remove the transmitter from its case by loosening the 16 wing-nuts and carefully pulling the transmitter forward. If the frequency indicator is to be lubricated, the front panel must be removed (par-

REMOVE FROM CASTING
TO SERVICE

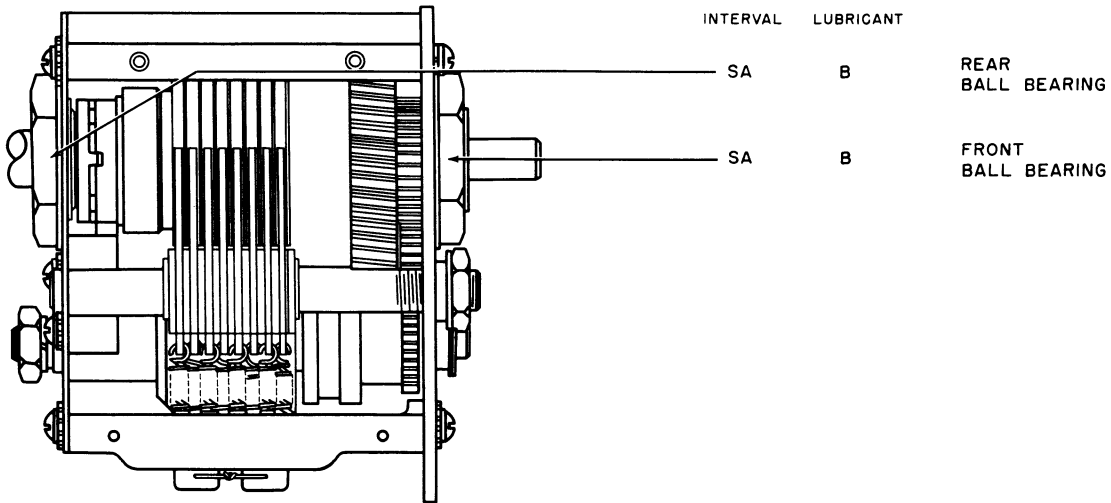

NOTE:

ALL LUBRICANTS ARE TO BE APPLIED USING A SMALL CAMEL HAIR BRUSH, IN AMOUNTS WHICH EACH LUBRICATION POINT WILL RETAIN. REMOVE ALL EXCESS.

LUBRICANT	INTERVAL
A-AN-0-6a OIL	SA-SEMIANNUALLY
B-MIL-G-3278 GREASE	

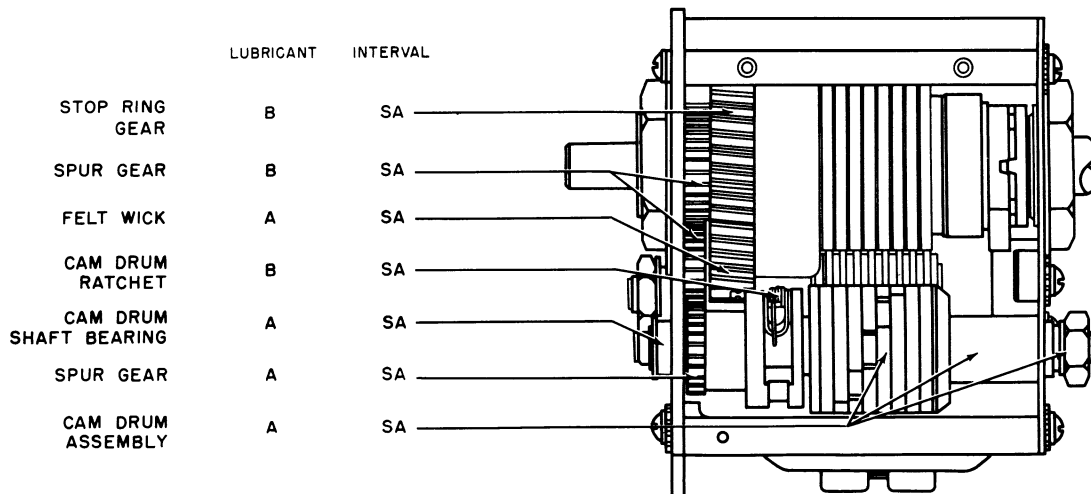

TM 806-89

Figure 117. Lubrication of Autotune singleturn head.

REMOVE FROM CASTING TO SERVICE

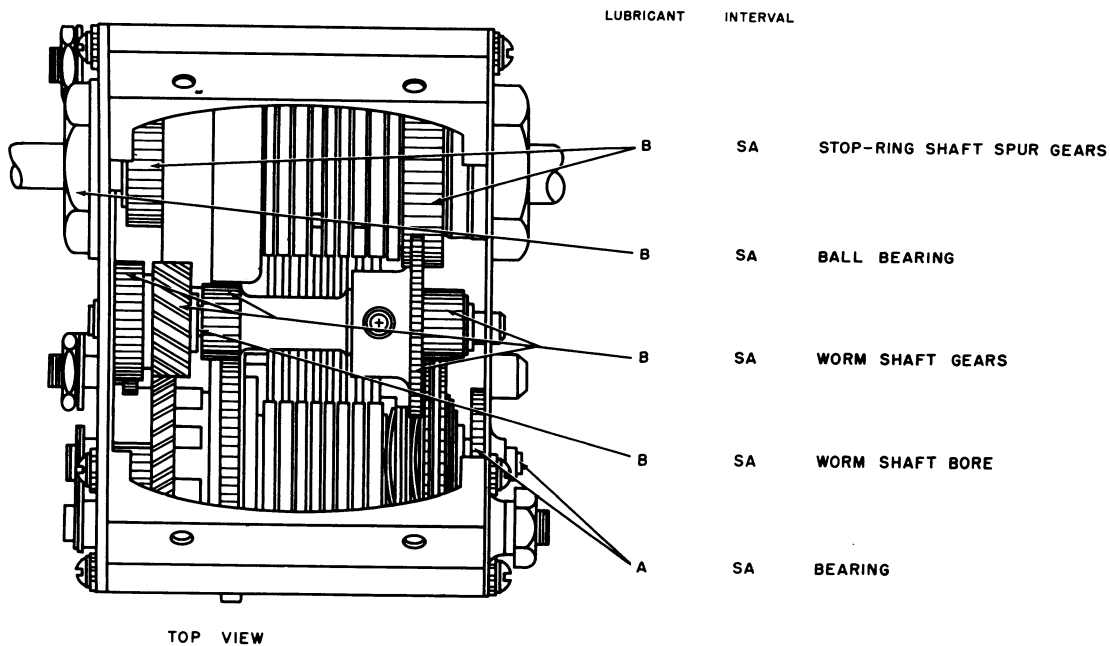

NOTE
 ALL LUBRICANTS ARE TO BE APPLIED, USING
 A SMALL CAMEL HAIR BRUSH, IN AMOUNTS
 WHICH EACH LUBRICATION POINT WILL RETAIN.
 REMOVE ALL EXCESS.

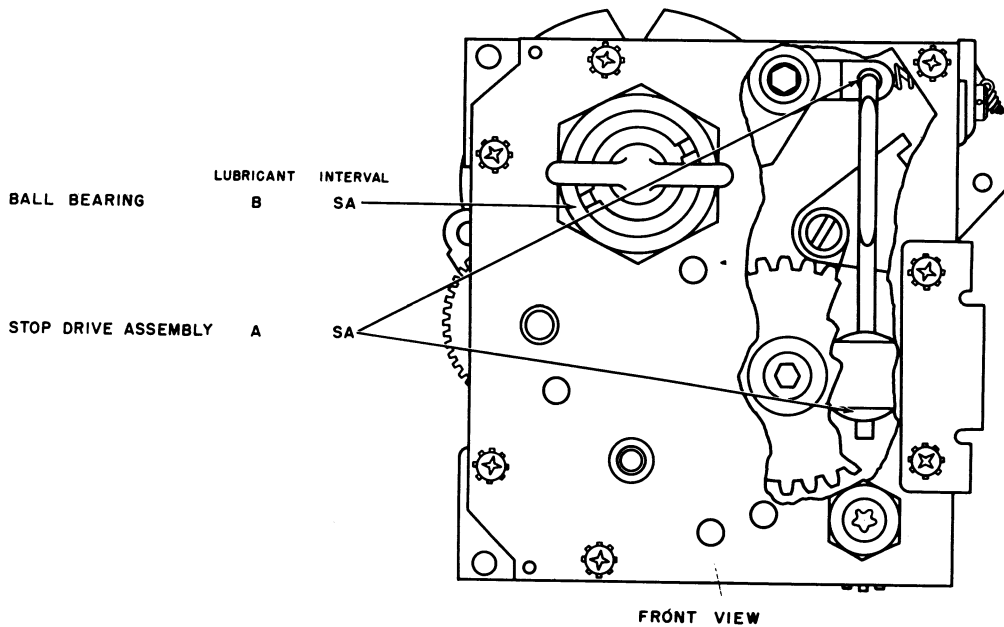

LUBRICANTS	INTERVAL
A-AN-O-6a OIL	SA-SEMIANNUALLY
B-MIL-G-3278 GREASE	

Figure 118. Lubrication of Autotune multiturn head, front and top views.

TM 806-111

REMOVE FROM CASTING TO SERVICE

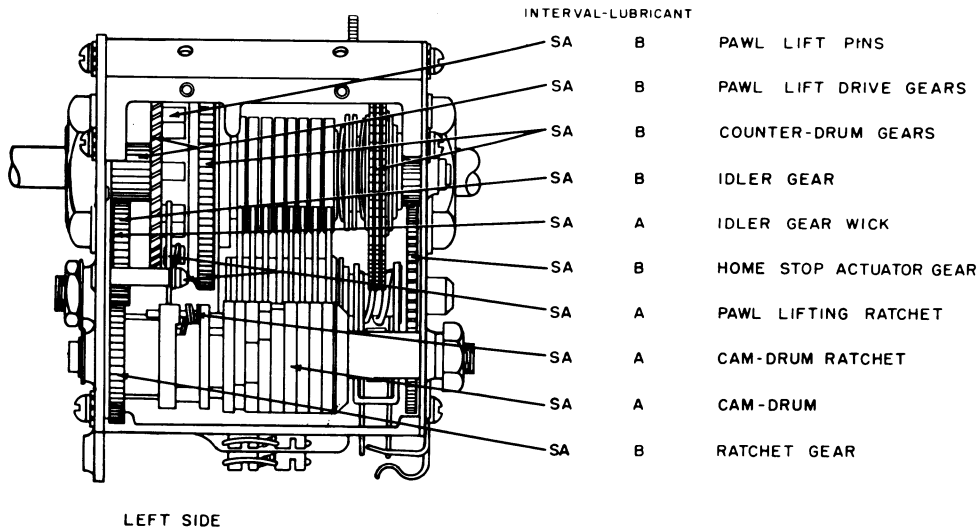

NOTE
 ALL LUBRICANTS ARE TO BE APPLIED, USING
 A SMALL CAMEL HAIR BRUSH, IN AMOUNTS
 WHICH EACH LUBRICATION POINT WILL RETAIN.
 REMOVE ALL EXCESS.

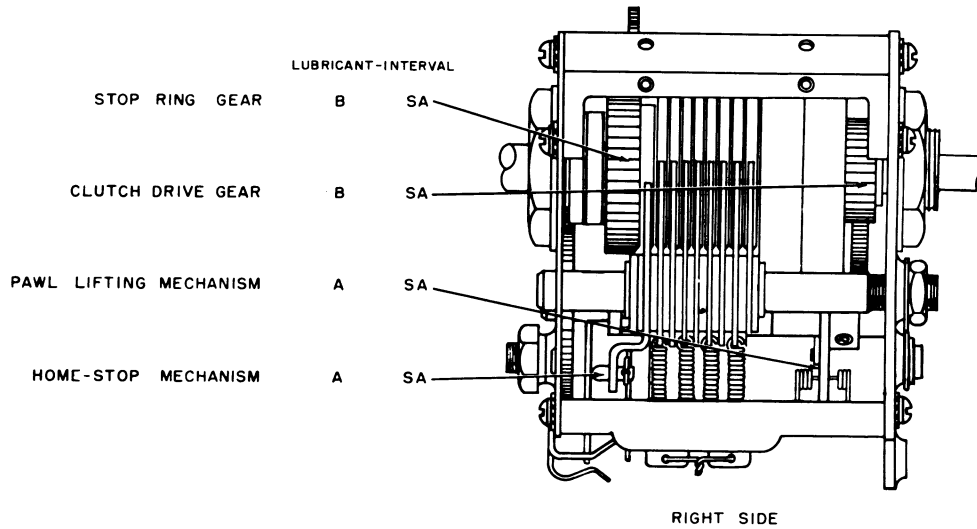

LUBRICANTS	INTERVAL
A-AN-O-6a OIL	SA-SEMIANNUALLY
B-MIL-G 3278 GREASE	

TM 806-112

Figure 119. Lubrication of Autotune multiturn head, left and right views.

REMOVE FROM CASTING
TO SERVICE

NOTE

ALL LUBRICANTS ARE TO BE APPLIED, USING A SMALL CAMEL HAIR BRUSH, IN AMOUNTS WHICH EACH LUBRICATION POINT WILL RETAIN. REMOVE ALL EXCESS.

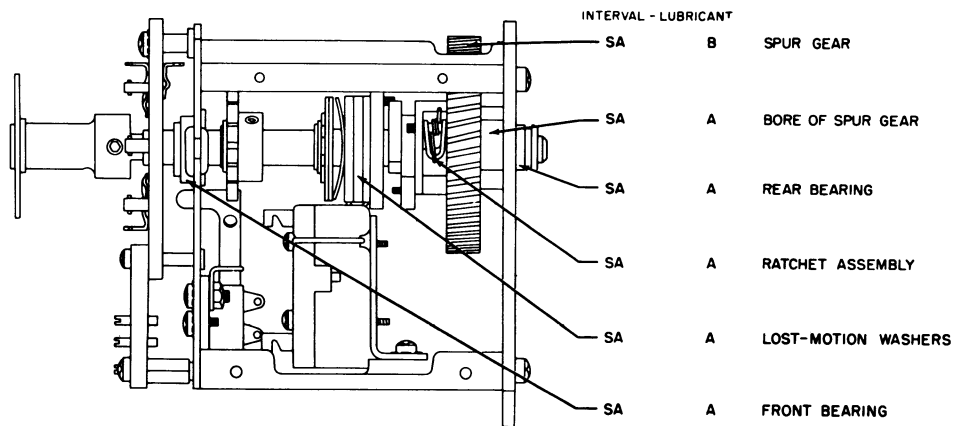

LUBRICANTS		INTERVAL
A	AN-O-6d OIL	SA-SEMIANNUALLY
B	MIL-G-3278 GREASE	

TM 806-110

Figure 120. Lubrication of Autotune control head.

108a). If the Autotune mechanism is to be lubricated, the frequency indicator must also be removed to permit access to the gear train. Use a thin, long-handled brush having medium bristles, dipped in solvent (SD). Remove the dirt, oil, and grease from the gears, cams, guide slots, and bearings. To gain access to all of the gear teeth while cleaning, rotate the BAND SELECTOR and TUNING CONTROL knobs. After dipping the brush in solvent (SD), remove the excess to prevent the solvent from dripping onto connecting cables, wiring, or other electrical parts. Use a clean, lint-free cloth moistened with solvent (SD) to remove grease from the metal casting and chassis. Thoroughly wipe all parts with a clean, dry, lint-free cloth before proceeding with lubrication. It is necessary to clean the Autotune mechanism before lubrication only if excessively noisy or irregular operation indicates dirt in the mechanism. The same cleaning procedures apply to the subchassis and main frame gear trains. Remove the master-oscillator, exciter, power-amplifier, antenna tuning capacitor, and variable inductor subchassis as

directed in paragraph 108, exposing the main frame gear train (figs. 98 and 99).

b. *Detailed Lubrication Instructions.* If any item or part of the transmitter is not mentioned in this paragraph, it needs no lubrication for the lifetime of the transmitter. To apply grease to the teeth of the gears in the main frame, and in the subchassis mentioned in *a* above, use a standard grease gun and a thin, long-handled brush. The same technique should be used in applying grease to the cam edges and guide slots of the cam followers (fig. 74). The two cam followers should each be lubricated with a drop of lubricating oil. In applying oil, dip a length of wire into the oil to collect a small drop at the end, and transfer the oil to the bearing by touching the end of the wire to the edge of the bearings. Avoid excessive amounts of oil. Lubricate the Autotune mechanism as indicated in figures 117 through 121. Rotate the singleturn and multi-turn shafts as necessary to expose all gear teeth for lubrication. The frequency indicator is lubricated as indicated in figure 122. The roller surface and teeth of the detent wheel should be lubri-

REMOVE FROM CASTING TO SERVICE

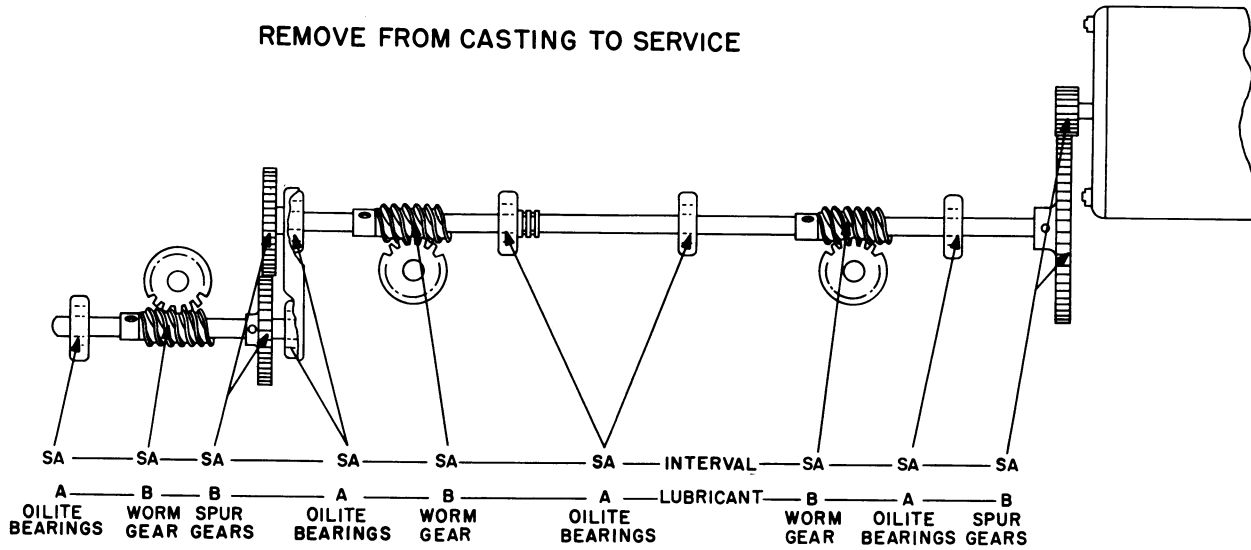

LUBRICANTS		INTERVAL
A	AN-O-6a OIL	SA-SEMIANNUALLY
B	MIL-G-3278 GREASE	

NOTE
 ALL LUBRICANTS ARE TO BE APPLIED, USING A SMALL CAMEL HAIR BRUSH, IN AMOUNTS WHICH EACH LUBRICATION POINT WILL RETAIN. REMOVE ALL EXCESS.

TM 806-109

Figure 121. Lubrication of Autotune line shaft.

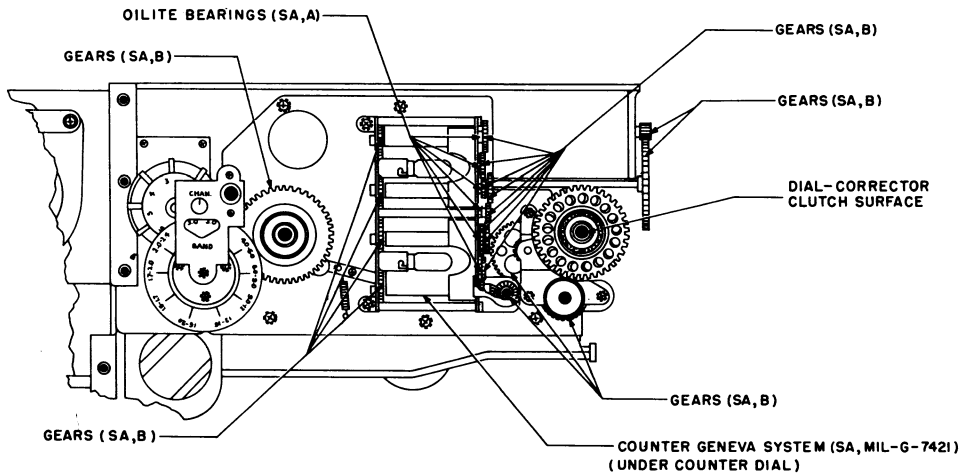

LUBRICATION		INTERVAL
A	AN-O-6a OIL	SA-SEMIANNUALLY
B	MIL-G-3278 GREASE	

TM806-96

Figure 122. Lubrication of frequency indicator.

cated with MIL-G-3278 grease semiannually. The bearing of the roller should be lubricated with AN-O-6a oil semiannually.

Caution: Make sure that no oil or grease collects on the surfaces of the slip clutch (fig. 95) of the antenna tuning capacitor and the dial corrector clutch face (fig. 122) of the frequency indicator.

c. Lubrication of Dynamotors. The dynamotors should be serviced at the end of every 250 hours of operation. Lubricate low-voltage dynamotor D601 and high-voltage dynamotor D602 as follows:

- (1) Wipe all dust and dirt from the fan and bearing brackets with a clean, dry cloth, and blow out all dust from the armature.
- (2) Remove the fan and bearings caps.
- (3) Remove the old grease from the bearing caps, and repack bearings with grease equivalent to grease (GL).

Caution: Add only enough grease to fill the bearings level with the races. Do

not overfill. Keep the grease off the commutators, and avoid smearing dirt on them.

111. Parts Lubricated by Manufacturer

Prior to delivery of Radio Transmitter T-195/GRC-19, the following parts are lubricated by the manufacturer:

a. Gears, cams, and guide slots—grease GL or an equivalent.

b. Bearings and cam followers—Lubricating Oil, General Purpose, Low Temperature, MIL-L-7870.

c. Autotune mechanism—Oil, Lubricating, Preservative, Special (PL Special) MIL-L-644A, and Grease, Aircraft and Instruments, MIL-G-3278.

112. Refinishing

Instructions for touchup painting are given in paragraph 37, and for refinishing badly marred panels or exterior cabinets are contained in TM 9-2851.

Section III. ALINEMENT AND ADJUSTMENT PROCEDURES

113. Test Equipment and Tools Required for Alinement and Adjustment

Refer to paragraph 96 for details of test equipment required for alinement and adjustment of Radio Transmitter T-195/GRC-19, and refer to paragraph 30 for details of the required special tools. In addition to the test equipment and special tools, the following are required:

a. Two noninductive resistors: one 73.5 ohms, 140 watts; and one 660 ohms, 5 percent, 5 watt; and the capacitors mentioned in paragraph 119*b* (2) (*b*). These items are required for the alinement and testing of the discriminator subchassis.

b. A bakelite alinement tool for adjusting the inductor cores and trimmer capacitors of the tuned circuits of the exciter subchassis.

c. A 0.248- to 0.249-inch diameter rod for the mechanical adjustment of the exciter subchassis.

114. Synchronization of Autotune Mechanism

The synchronization of the Autotune system involves the adjustment of the angular positions of the cam drums and seeking switch S605 (fig. 103). This adjustment insures the proper selec-

tion of the channel chosen by the switch. After any repairs have been made to either the single-turn or multiturn head or to the control head, the Autotune system should be synchronized. Before replacing the front panel, synchronize the Autotune mechanism by following the procedure in the order given in *a*, *b*, and *c*, below:

a. Autotune Control Head.

- (1) Loosen the T-handles on both Autotune heads.
- (2) Insert a No. 10 Bristo wrench into the end of the line shaft. When facing the gear at the end of the line shaft, rotate the line shaft counterclockwise until any rotor contact of the control unit switch is on the verge of contact with a stator contact. With additional shaft rotation, the breaker switch tab in the control unit proceeds with an audible snap to the extreme left position. Stop rotation of the line shaft immediately at this point. The preceding operation may be accomplished at any of several successive positions during the switch rotation.

- (3) Rotate the line shaft clockwise $3\frac{1}{2}$ to $3\frac{5}{8}$ revolutions from the position located; then stop.
- (4) Rotate the shaft on each Autotune head clockwise until the stop is reached; then counterclockwise until the stop is reached. The T-locking bars are still loose at this point.
- (5) Tighten the T-locking bars on both Autotune heads. Try to turn the knobs. If either knob rotates with the T-locking bars tightened, it will be necessary to repeat (1) through (3) above until no rotation occurs when the heads are locked.

b. Autotune Multiturn Head. Insert a No. 10 Bristo wrench into the end of the cam drum shaft of the Multiturn Autotune and rotate the cam drum counterclockwise as far as possible. While holding the cam drum in this position, loosen the cam drum nut by rotating the nut clockwise. Again rotate the cam drum counterclockwise as far as possible. While holding the cam drum in this position, tighten the cam drum by rotating the nut counterclockwise, using from 35 to 40 inch-pounds of torque.

c. Autotune Singleturn Head. Insert a No. 10 Bristo wrench into the end of the cam drum shaft of the Singleturn Autotune, and rotate the cam drum clockwise as far as possible. While holding the cam drum in this position, loosen the cam drum nut by rotating the nut counterclockwise. Again, rotate the cam drum clockwise as far as possible. While holding the cam drum in this position, tighten the cam drum nut by rotating the nut clockwise, using from 35 to 40 inch-pounds of torque.

115. Adjustment of Modulator Subchassis

- a.* Remove the transmitter from its case and set it up for voice operation as directed in paragraph 15. Make sure that interlock switch S611 (fig. 5) is closed; one method of activating the switch is to pull out the plunger.
- b.* Check to see that the input line voltage is between 28 and 29 volts dc; then operate the transmitter for voice as directed in paragraph 23.
- c.* Turn the RELAY-NORMAL-DUPLEX switch to RELAY, and set the LINE LEVEL control to -34.
- d.* Connect an audio oscillator to pin H of AUDIO receptacle J604, and set the oscillator to

deliver an output of .015 volt root mean square (rms) at a frequency of 1,000 cycles.

Note. Extreme care must be taken to insure that all circuits associated with this input circuit are adequately shielded and grounded, since this setting of the LINE LEVEL control means that maximum modulator gain is available. Inadequate shielding or grounding will result in rf feedback.

e. Turn CLIPPING control R414 (fig. 123) to its CCW stop and adjust MODULATION control R419 (fig. 123) so that meter M603 indicates 100 percent. The 100-percent indication is obtained when the modulator is delivering 707 volts rms output. Lock R419.

f. Turn CLIPPING control R414 in a clockwise direction until the indication on meter M603 decreases to 85 percent. Lock R414.

g. The output from the sidetone amplifier may be adjusted to any convenient value by adjusting SIDETONE control R436 (fig. 123).

116. Synchronization of Band Switch in Exciter Subchassis

Whenever the exciter subchassis is replaced and the synchronization of band switch S101 with the BAND SELECTOR control is lost (as shown on the band-channel indicator), realine band switch S101 as follows:

- a.* Loosen the clamp screw that holds the exciter band-switch coupler to the band-switch shaft.
- b.* Set exciter band switch S101 to the 1.5- to 1.7-mc band (see fig. 124 for switch positions).
- c.* Mount the exciter in the transmitter frame and engage the band-switch and cam-shaft couplers.
- d.* Insert a screwdriver in the slot at the rear of the band-switch shaft of the exciter so that the shaft does not move, and rotate the BAND SELECTOR control to the 1.5- to 1.7-mc range.
- e.* Tighten the exciter band-switch coupler clamp.
- f.* Loosen the clamp screw which secures the camshaft coupler.
- g.* Set TUNING CONTROL to 3 mc.
- h.* Lift the exciter slug rack and turn the cams (fig. 74) so that a 0.248- to 0.249-inch diameter rod may be inserted through both exciter end-plate slots and through the holes in the cams.
- i.* Tighten the camshaft clamp screw, remove the rod, and complete the replacement of the exciter subchassis in the main frame.

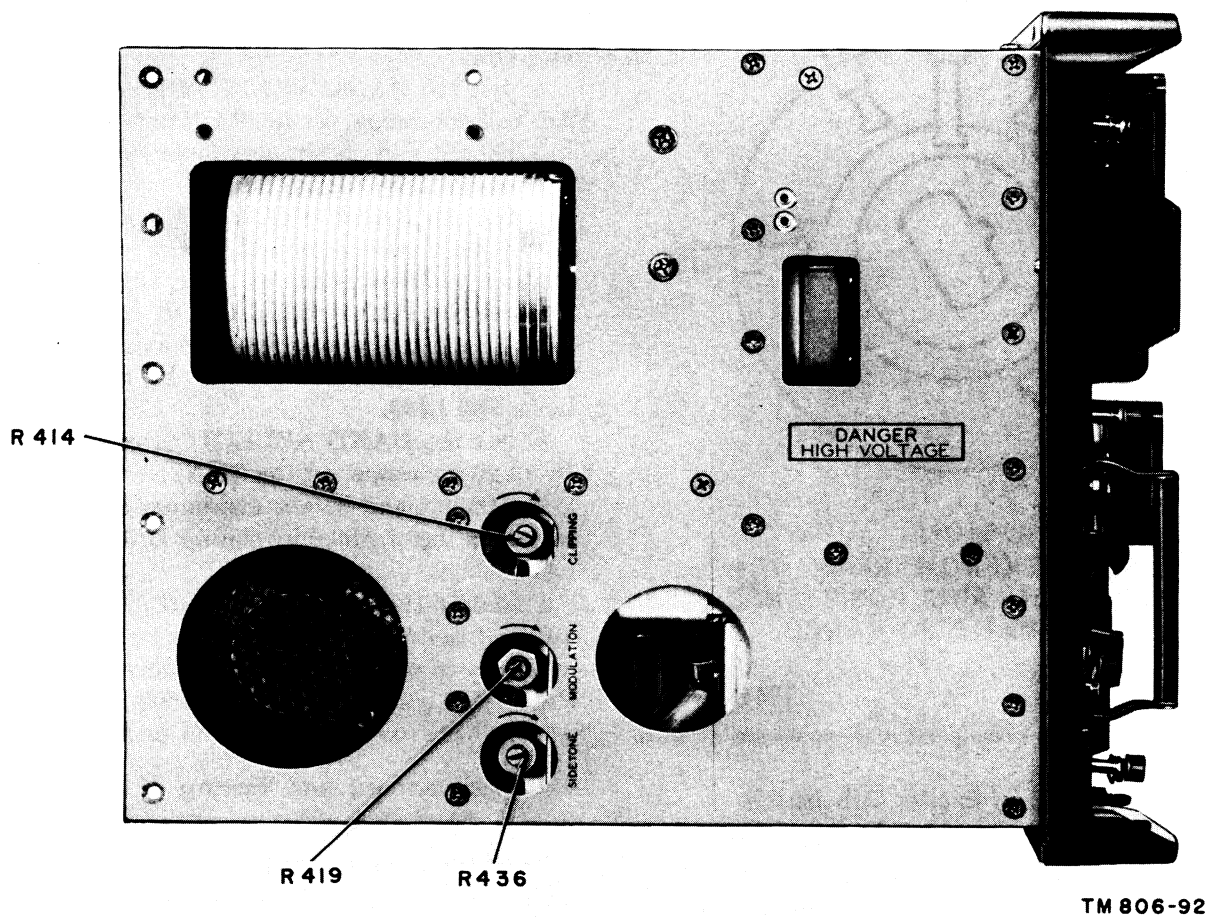

Figure 123. Radio Transmitter T-195/GRC-19, modulator adjustments.

117. Synchronization of Bank Switch in Power Amplifier Subchassis

If the power amplifier subchassis is removed or replaced, the band switch can be synchronized as follows:

a. With the power amplifier subchassis removed from the transmitter, adjust band-switch shaft so that the red arrow on the rear of the switch lines up with the red line (fig. 79). This will adjust the switch to the 1.5- to 1.7-mc range position.

Note. In figure 79, the cover plate has been removed. It is not necessary to remove the plate, however, because a hole has been provided in it also.

b. Note the position of the cam of S203 (fig. 78). The switch arm should be exactly centered in a detent of the cam. Adjust if necessary.

c. Use a No. 10 Bristo wrench and loosen the setscrew of the clamp which fastens the Oldham

coupler (fig. 78) to the BAND SELECTOR shaft.

d. At the front panel of the transmitter, note the band setting of the BAND SELECTOR, for later reference. Loosen the BAND SELECTOR locking key, and rotate the knob to the 1.5- to 1.7-mc range position.

e. Install the power amplifier subchassis onto the main frame; be careful not to change the position of the band-switch shaft. Engage the Oldham coupler snugly and tighten the clamp. The power amplifier band switch should now be properly synchronized with the other BAND SELECTOR components.

f. With the locking key still loosened, rotate the BAND SELECTOR back to the original position noted in *d* above; then lock the key.

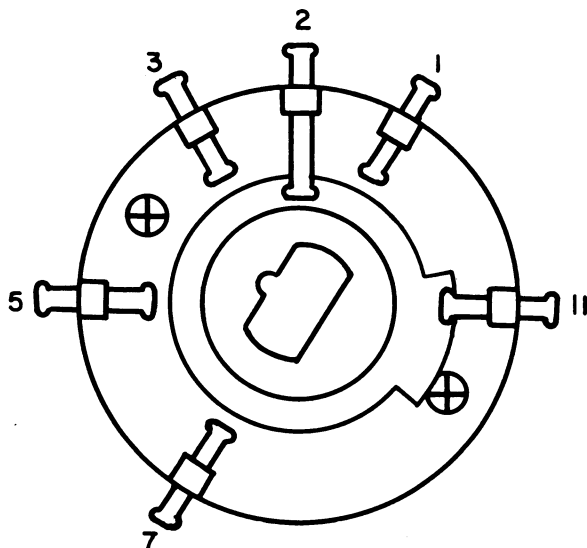

S101A
VIEWED FROM REAR OF
EXCITER AND POSITIONED
FOR 1.5 TO 1.7 MC RANGE

TM 806-123

Figure 124. Exciter band switch synchronizing position.

118. Alinement of Exciter Subchassis

The variable capacitors and inductors for alinement of the exciter-tuned circuits are accessible through holes on the slug rack of the exciter (fig. 71). To aline the exciter subchassis, refer to figure 71 and proceed as follows:

- a. Turn all slug studs on coils L101 through L110 so that they extend about $\frac{1}{16}$ inch above the top of the slug-rack surface.
- b. Set the SERVICE SELECTOR switch to the CALIB position and the TEST METER switch to PA GRID.
- c. Set the BAND SELECTOR control to the 1.5- to 1.7-mc range.
- d. Adjust capacitor C136 to obtain maximum indication on the PA GRID of test meter M602.
- e. Set the BAND SELECTOR control to the 3.0- to 4.0-mc range and obtain maximum current indication on test meter M602 by tuning C107, C111, and C138.
- f. Set the BAND SELECTOR control to the 6.0- to 9.9-mc range and obtain maximum current indication on M602 by tuning C118, C122, and C140.

g. Set the BAND SELECTOR control to the 12.0- to 16.0-mc range and obtain maximum current indication on M602 by tuning C129, C131, and C141.

h. Set the BAND SELECTOR control to the 2.4- to 3-mc range, set the TUNING CONTROL to 2.900 mc, and obtain maximum current indication on M602 by tuning L107.

i. Set the BAND SELECTOR control to the 4- to 6-mc range and obtain maximum current indication on M602 by tuning L101, L102, and L108.

j. Set the BAND SELECTOR control to the 9- to 12-mc range and obtain maximum current indication on test meter M602 by tuning L103, L104, and L109.

k. Set the BAND SELECTOR control to the 16- to 20-mc range, set the TUNING CONTROL to 19.200 mc, and obtain maximum current indication on meter M602 by tuning L105, L106, and L110.

l. Repeat the procedure of c through k above until no tuning of the capacitors or inductors is necessary to yield maximum indication within the PA GRID scale on test meter M602. These steps usually have to be repeated three or four times.

119. Adjustment and Testing of Discriminator Subchassis

For the purposes of this adjustment, the discriminator subchassis is divided into two sections. The section of the discriminator which includes L304A, CR303, CR304, and C305 (fig. 48) will be referred to as the *loading discriminator*. Its dc output appears at pin F of P302. The section containing L304B, CR301, and CR302 (fig. 46) will be referred to as the *phasing discriminator*. The dc output of the phasing discriminator appears at pin B of P302. The only section of the discriminator which requires adjustment is the loading discriminator. However, before the adjustment of the discriminator subchassis can be considered satisfactory, both the loading and phasing sections should be tested. For this reason, both an adjustment procedure and a testing procedure are provided.

a. Discriminator Adjustment.

- (1) Remove the discriminator subchassis as directed in paragraph 108. Connect bench-test cable No. 4 (fig. 65) between P302 (fig. 84) and J609 (fig. 97).
- (2) Loosen the antenna-tuning capacitor subchassis from the transmitter frame. Dis-

connect it from the variable inductor and the discriminator subchassis, and move the antenna-tuning capacitor subchassis so that it projects from the rear of the transmitter. Keep plug P1001 (fig. 94) connected, and place the antenna-tuning capacitor subchassis in a free-operating position at the rear of the transmitter.

- (3) Prior to discriminator adjustment and testing, it is advisable to check CR301, CR302 (fig. 82), CR303, and CR304 for faults (par. 107).
- (4) Between the discriminator rf output (P303) and ground (the point at which the antenna-tuning capacitor normally connects to the discriminator), connect the 73.5-ohm resistor which will act as the rf load.
- (5) Remove discriminator plug P302 and insert a piece of wire in J609-F (described in paragraph 99a), and reconnect plug P302. Connect a 20,000 ohms-per-volt meter between the wire and ground. Set the meter to its 2.5-volt dc scale.
- (6) Close switch S611. Rotate the SERVICE SELECTOR switch to its CW position, set the TUNING CONTROL and BAND SELECTOR control for 12,000 kilocycles (kc), connect the 73.5-ohm load to the discriminator, and close the TEST KEY.
- (7) The dc meter connected to pin F of P302 and ground should indicate $\pm .02$ -volt dc. If the correct indication is not obtained, adjust C305 (fig. 82) until the proper residual error occurs. This adjustment should be the only one necessary in the alignment of the entire discriminator.

b. Discriminator Testing.

(1) *Loading discriminator.* Testing of the loading discriminator after its adjustment requires the same equipment set-up as for adjustment. The testing procedure is as follows:

- (a) At 1,700 kc, shunt the rf load with a 660-ohm ± 5 percent noninductive resistor at the discriminator rf output. Shunting the 73.5-ohm load with the 660-ohm resistor introduces a 10 percent change in the resistive component of the load to the power amplifier. This change in power-amplifier load

should appear as a change in the dc output of the loading discriminator at pin F of P302. To indicate satisfactory operation of the loading discriminator, the total change of dc output voltage should be equal to, or greater than, the residual error voltage.

- (b) To determine whether the loading discriminator is operating satisfactorily, it must be further tested at 3,000 kc, 12,000 kc, and 20,000 kc. With the transmitter operating at 3,000 kc, the residual error voltage at pin F of P302 should be noted. It will vary from that obtained at 1,700 kc, but the condition is normal, and no further adjustment of C305 should be made. The rf load should then be shunted at the discriminator rf output with the 660-ohm resistor. As in (a) above, the total change in error voltage should be equal to, or greater than, the error voltage. For example, if the residual error voltage at 3,000 kc is + 0.05 volt, and shunting the 3,000-kc load with a 660-ohm resistor changes this error voltage to +0.27 volt, the total change in error voltage is 0.22 volt. Since 0.22 volt is greater than 0.05 volt, the loading discriminator is operating satisfactorily at 3,000 kc.
- (c) At 17,000 and 20,000 kc, the discriminator rf load should be 73.5 ohms. In each case, the change in error voltage is compared to the residual error and should be equal to, or greater than, the typical error. The following typical readings are given for an example:

Frequency (kc)	Typical error voltage (volts)	Error voltage with a 660-ohm shunt (volts)	Change in error voltage (volts)
1,700 -----	+0.03	+0.14	0.11
3,000 -----	+ .05	+ .27	.22
12,000 -----	*0	+ .6	.6
20,000 -----	+ .15	+ .75	.6

*This value set by adjustment of C305.

(2) *Phasing discriminator.*

- (a) The procedure for testing the phasing discriminator is almost the same as that used for testing the loading dis-

criminator; however, no initial adjustment is necessary, and a capacitor is used to shunt the rf load.

- (b) At 1,700 kc, connect the 73.5-ohm rf load across the discriminator rf output and note the dc error voltage at pin B of P302. Shunt the rf load with a 128-micro-microfarad ($\mu\mu\text{f}$) capacitor and note the total change in error voltage. The total change in error voltage must be equal or greater than the typical error for satisfactory operation. Repeat the above procedure for 3,000; 12,000; and 20,000 kc, using the shunts indicated below. Typical data for the phasing discriminator are as follows:

Frequency (kc)	Typical error voltage (volts)	Value of shunting capacitor ($\mu\mu\text{f}$)	Error voltage when shunted with capacitor (volts)	Change in error voltage (volts)
1,700-----	-0.05	128	+0.03	0.08
3,000-----	0	73	+.13	.13
12,000-----	-.25	18	+.15	.40
20,000-----	-.05	11	+.35	.40

Note. Difficulty in obtaining satisfactory discriminator performance can usually be attributed to incorrect discriminator rf loads, transmitter operating frequency not set accurately, and, in the case of the phasing discriminator, CR301 and CR302 not sufficiently well balanced.

120. Alinement and Calibration of Master-oscillator Subchassis

When replacing the master-oscillator subchassis with a subchassis from supply, or if the mechanical relationship between the tuning shaft of the subchassis and the TUNING CONTROL setting has been disturbed during removal or replacement (par. 108), aline the master-oscillator subchassis as follows:

Caution: Extreme care must be taken with the master-oscillator shaft to make certain that it is never forced against its end stops. *a* through *h* below are to be performed with the master oscillator completely unmeshed from the multiturn head.

- a.* Set the BAND SELECTOR control to the 16.0- to 20.0-mc range, as indicated on the band-channel indicator.
- b.* Lock the tuning control multiturn head by tightening the T locking bar on the TUNING CONTROL knob.

c. Set the DIAL ZERO control to the midpoint of its range.

d. Set the BAND SELECTOR control to the 1.5- to 1.7-mc range.

e. Unlock the TUNING CONTROL knob and rotate it counterclockwise until the Autotune stop is reached.

f. At this time, the counter should indicate a frequency of 1.445 mc. If the counter does not indicate a frequency within this range, loosen the setscrews that tighten the counter clutch (bank of four gears) to the tuning control multiturn head, and rotate the entire bank of four gears with respect to the Autotune shaft until a reading between 1.440 and 1.450 is obtained on the counter when the tuning control multiturn head is at its counterclockwise stop position. Tighten the setscrews.

g. Turn the SERVICE SELECTOR switch to the CALIB position, and allow the mo subchassis a 10-minute warmup period, then measure the output frequency of the transmitter as outlined in paragraph 21. See that the fundamental frequency is measured.

h. Set the TUNING CONTROL to indicate this measured fundamental frequency and lock the TUNING CONTROL knob.

i. Insert the mo subchassis into its position in the main frame, and mesh the loaded gear on the mo shaft (with 2-tooth loading) to the TUNING CONTROL Autotune shaft gear. Do not tighten the setscrews in the hub of the loaded gear until it has been determined that the mo frequency and counter indication are in agreement. If they are not in agreement, rotate the TUNING CONTROL with the loaded gear slipping on the mo shaft until the counter indicates the mo frequency. Tighten the setscrews in the mo loaded gear.

j. Rotate the TUNING CONTROL slowly over its range and determine that no binding occurs, then complete the replacement of the mo subchassis.

121. Adjustment of Speed Regulator.

The speed regulator for the 115-volt, 400-cps output consists of a centrifugal-type switch (governor) located on one shaft end of low-voltage dynamotor D601. When the rotation of the shaft decreases beyond a certain speed, contacts on the governor open; this introduces a resistor (located internally) in series with the 24-volt input winding of D601. Field current and flux are lowered,

causing the speed of rotation to increase. When the rotation of the shaft increases beyond a certain speed, centrifugal force causes the contacts to close and short out the resistor. The resultant increase in field current and flux will decrease the speed of rotation. To check the speed of rotation of the dynamotor and adjust the governor, proceed as follows:

a. Connect a 600-ohm, 50-watt resistor between ground and terminal 4 (the 115-volt, 400-cps output), and connect a 5,000-ohm, 2-watt resistor between ground and terminal 2 (the 250-volt dc output), and connect a 5,000-ohm, 2-watt resistor between ground and terminal 3 (the -45-volt dc output). Replace the power cable and secure the dynamotor to the main frame, or carefully place the dynamotor in such a position that it cannot move. Check to see that all exposed wiring or parts are properly insulated or clear of any grounded point, then turn the SERVICE SELECTOR switch to CALIB. Connect the 400-cps output, located at terminal 3 of E602 (fig. 98), to the vertical plates of an oscilloscope, and connect the 400-cycle output from an audio signal generator to the horizontal plates. If necessary, vary the audio oscillator frequency to obtain a 1:1 ratio figure, such as a diagonal line, a circle, or an ellipse, on the screen of the oscilloscope. If the audio oscillator setting does not fall between 380 and 420 cycles, proceed with the next step.

b. Remove the brush cover on the input side of the dynamotor to expose the governor. The governor should be moved to a position where its operating contact is on the right. If the dynamotor rotates too fast, the top facing screw should be turned once in a clockwise direction; if the speed of rotation is too slow, the screw should be turned once in a counterclockwise direction. The bottom facing screw permits greater range of speed adjustment; it should only be used when the top facing screw cannot provide speed compensation. Adjust the governor until the audio oscillator reading is between 380 to 420 cps for a 1:1 ratio figure on the oscilloscope.

122. Adjustment of Frequency-indicator Assembly

(fig. 103)

Proper adjustment of the frequency-indicator assembly requires synchronization of the counter dial shutter mechanism, band indicator, and chan-

nel indicator with the BAND SELECTOR switch to indicate bands and channels correctly.

a. *Channel Indicator.* To adjust the channel indicator disk, proceed as follows:

- (1) Remove the front panel of the transmitter.
- (2) Use a No. 10 fluted socket wrench and loosen the setscrew which fastens the channel indicator disk to the shaft of S605.
- (3) Rotate the channel indicator disk so that the channel position, to which the PRESET CHANNELS switch is positioned, can be read through the opening in the mask marked CHAN. BAND.
- (4) Tighten the setscrew, making certain that the disk does not rub the band indicator disk or the gear. Replace the front panel.

b. *Counter-Dial Shutter Mechanism.* To adjust the counter-dial shutters, proceed as follows:

- (1) Rotate the PRESENT CHANNELS switch to the M (manual) position.
- (2) Loosen the locking key on the BAND SELECTOR knob, and rotate the BAND SELECTOR to the 1.5- to 1.7-mc range.
- (3) Remove the front panel.
- (4) Use a No. 10 fluted socket wrench and loosen the setscrew that fastens the collar of the cam gear to the BAND SELECTOR shaft. Do not rotate the BAND SELECTOR shaft.
- (5) Disengage the cam gear from the band indicator disk gear, and rotate the cam gear in a counterclockwise direction until the first shutter snaps closed, and the last or bottom shutter opens. The shutter lever roller must ride on the cam during this step.
- (6) Depress the shutter lever to open the first shutter, and rotate the cam gear in a clockwise direction until the cam holds the first shutter open. Engage the band indicator disk gear with the cam gear, and tighten the setscrew of the cam gear.
- (7) Secure the BAND SELECTOR knob to the shaft, leaving the locking key loose. Rotate the BAND SELECTOR to both limits, in turn, to check the shutter operation.

- (8) If the shutter operation is satisfactory, remove the BAND SELECTOR knob and replace the front panel. If the shutter operation is not satisfactory, repeat the procedure, beginning with (2) above, and readjust as necessary.

c. Band indicator. To adjust the band indicator disk, proceed as follows:

- (1) Rotate the PRESET CHANNELS switch to the M (manual) position.
- (2) Loosen the locking key on the BAND SELECTOR knob, and rotate the BAND SELECTOR to the 1.5- to 1.7-mc range.
- (3) Remove the front panel.
- (4) Use a No. 10 fluted socket wrench and loosen the setscrew that fastens the collar of the cam gear to the BAND SELECTOR shaft. Do not disturb the cam setting with regard to the shutter lever of the counter-dial mechanism.
- (5) Move the cam gear slightly forward, so that the band-indicator disk rotates freely, and adjust the disk to indicate 1.5- to 1.7-mc.
- (6) Move the cam gear back to engage the band-indicator gear, and tighten the setscrew.
- (7) Replace the front panel.

123. Adjustment of Antenna-Tuning Capacitor

a. Adjustment of the antenna-tuning capacitor consists of setting the switches for the following conditions.

- (1) S1001 must be open except when S1002, C1002, and C1003 are at minimum or maximum capacity position and there is torque on B1001.
- (2) S1003 must be operated when S1002 is at minimum capacity position.
- (3) C1002 and C1003 must reach minimum and maximum capacity positions before S1002.

b. Adjust as follows:

- (1) Remove antenna tuning capacitor subchassis from the main frame as outlined in paragraph 108.
- (2) Rotate the gear (which drives S1002) by hand to the last detent position of S1002. This will be the position at which only

one contact (C1003) touches the contacting bar of S1002.

- (3) Loosen the two mounting screws of S1003 and adjust S1003 so that it is operated properly without undue tension when the gear that drives S1002 is rotated against spring tension until S1001 closes as shown in figure 125.

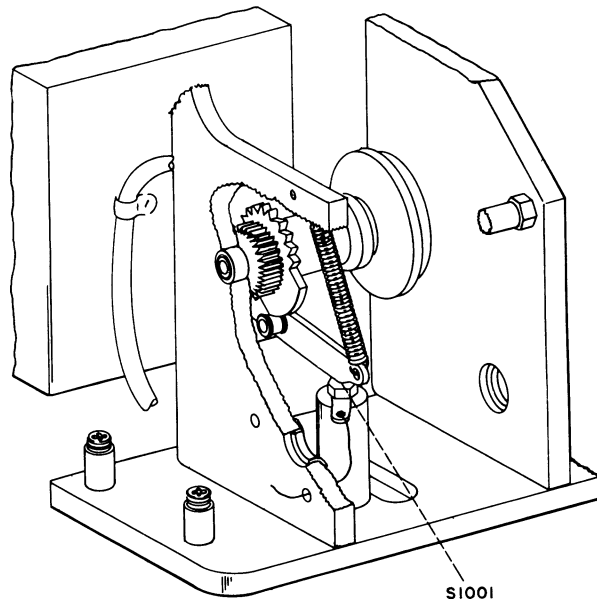

S1001
VIEWED FROM REAR OF
ANTENNA TUNING CAPACITOR AND SET
AT MINIMUM CAPACITY POSITION

TM806-124

Figure 125. Antenna tuning capacitor synchronization.

- (4) Check that C1002 and C1003 are at minimum capacity (plates out of mesh). If either capacitor does not reach minimum, loosen the clamp that fastens the gear to the shaft of the faulty capacitor. Rotate the capacitor to minimum, and retighten the clamp.
- (5) Replace the subchassis onto the main frame.

124. Adjustment of Variable Inductor

Refer to paragraph 108 for this adjustment.

125. Synchronization of Output Capacitor

Synchronization of the output capacitor consists of adjusting S612 and S614. These switches must be properly positioned with respect to each other, and with respect to the BAND SELECTOR. Proceed as follows:

a. Remove the variable inductor subchassis as outlined in paragraph 108.

b. Note the setting of the BAND SELECTOR on the BAND indicator, then loosen the locking key and rotate the BAND SELECTOR to the 12-16 mc band.

c. Connect an ohmmeter between the junction of C653, C663, and C656 and the rotor arm of S612A. Rotate the large gear (which meshes with the small gear on the shaft of the dc motor (B603)) by hand until a continuity reading is obtained. Center the contacts at this position.

d. Connect the ohmmeter between contact 9 of S614A rear and ground. (See note below.) No continuity should be obtained. If it is, loosen the clamp which fastens the switch gear to the rotor shaft of S612; then rotate the large gear (c above) until an open circuit is obtained. At this position, S614B rear should appear as in figure 126. Make certain that the switch contacts are exactly centered at this position, and retighten the clamp.

Note. Locate contact 9 of S614B rear. Contact 9 of S614A rear will be in line with it.

e. Return the BAND SELECTOR to the BAND setting noted in b above, then tighten the

locking key. Replace the variable inductor subchassis.

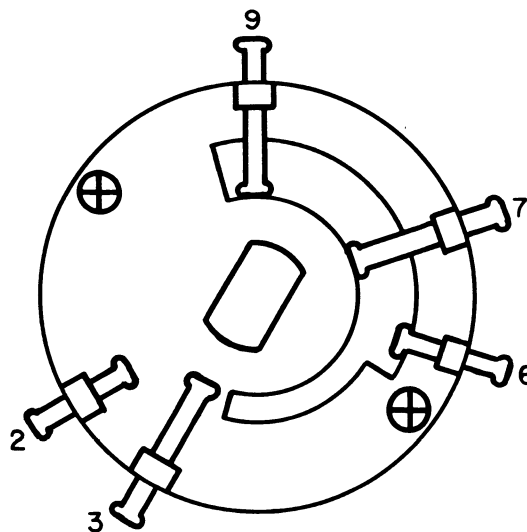

S614B REAR
POSITION FOR
12 TO 16 MC RANGE

TM 806-125

Figure 126. Output capacitor synchronization.

Section IV. FINAL TESTING

126. General

Paragraphs 127 through 130 give the final performance tests of the equipment. Repaired equipment meeting these performance tests will furnish uniformly satisfactory operation. All of the tests in this section are to be performed while operating the transmitter with a 28.5-volt dc input. Allow the transmitter to warm for 10 minutes before making any measurements. If the desired results are not obtained, further repairs are necessary.

Warning: The voltages used are high enough to endanger human life. Personnel should take every precaution to minimize the danger of shock.

127. Test Equipment Required

The test equipment required for final testing of Radio Transmitter T-195/GRC is listed below:

Spectrum Analyzer TS-723/U.

Audio Oscillator TS-382A/U.

Oscilloscope OS-8/U.

Electronic Multimeter ME-6/U.

Radio Receiver R-392/URR and cables.

Microphone M-29/U.

RF Ammeter IS-76.

Antenna A-27.

Dummy test antenna (fig. 66).

Motor-generator set, 28.5 volts dc.

Stop watch, 1 to 60 seconds.

Ammeter, stock No. 3F1200-4.

128. Conditions of Test

a. All tests should be conducted at existing conditions of temperature, pressure, and humidity, with the transmitter removed from the case and the interlock switch pulled all the way out.

b. Power should be supplied from a 28.5-volt dc source capable of regulation of ± 0.5 volts within a maximum load of 50 amperes. The supply also must be capable of supplying momentary surge currents of 250 amperes maximum for 0.5-second intervals, while permitting a voltage drop during the surge of not more than 14 volts.

129. Preliminary Procedures

a. Connect the equipment for normal operation (par. 15).

b. Set the RELAY - NORMAL - DUPLEX switch to the NORMAL position.

c. Set the TEST-METER switch to the PA CATH position.

d. Rotate the LINE LEVEL control to its full clockwise position.

e. Connect the power cable to the 24 VOLTS DC receptacle and adjust the power source to 28.5 volts dc.

f. Connect the dummy test antenna to the WHIP ANTENNA (fig. 66).

130. Test Procedures

a. Rotate the SERVICE SELECTOR switch to the CALIB position and measure the elapsed time until the low-voltage dynamotor is heard to start. This should be between 30 and 50 seconds.

b. Check the blowers at all three vents for correct operation. Intake suction should be felt at the large vent, exhaust air should be felt at the two smaller vents.

c. Rotate the TEST METER switch to the BATT position. The needle should fall within the area labeled BATTERY.

d. Rotate the PRESET CHANNELS switch to the M position, and unlock the BAND SELECTOR and TUNING CONTROL knobs.

e. Turn the TEST METER switch to the PA GRID position and peak the pa grid current by tuning the driver stage trimmers at the following settings:

Band	Frequency	Capacitor to be tuned
1.5-1.7	1.5	C136
3-4	3.0	C138
6-9	6.0	C140
12-16	12.0	C141

f. Manually rotate the BAND SELECTOR knob slowly through all ten bands. The meter needle must fall within or above the light area labeled PA GRID at all band positions.

g. Set the BAND SELECTOR knob to the 16-20 mc band and rotate the TUNING CONTROL knob slowly from 11.990 to 20.010 mc. There should be no sudden drop in grid current, and the meter needle should indicate as described in f above throughout the range covered. Repeat this procedure with the BAND SELECTOR in the 9.0- to 12.0-mc band, and the TUNING CONTROL rotated from 5.99 mc to 12.010 mc.

h. Rotate the DIAL DIM switch through its first three positions, and check for proper operation.

i. Preset the channels as indicated below, using Radio Receiver R-392/URR, as monitor. Refer to paragraphs 20 and 21.

Channel	Band	Frequency (mc)
M	1.5-1.7	1.50
1	2.0-2.4	2.40
2	3.0-4.0	3.40
3	4.0-6.0	4.40
4	6.0-9.0	7.00
5	9.0-12.0	12.00
6	12.0-16.0	15.00
7	16.0-20.0	20.00

j. Rotate the SERVICE SELECTOR switch to the CW position. Slowly vary the input voltage through the range of 22 to 30 volts dc and check for mechanical resonances. All mechanical resonances must be eliminated.

k. Check for continuity as follows:

(1) With the SERVICE SELECTOR in the CW position, key the transmitter and check for continuity between the RECEIVER ANTENNA connector and chassis. This should be less than 1 ohm.

(2) Check for continuity between the RECEIVER CONTROL receptacle, pin B, and chassis. The transmitter should be keyed during check. This reading should be not more than 3 ohms.

(3) Rotate the SERVICE SELECTOR switch to OFF. Check for continuity between the MO OUT connector and FSK IN jack. This should indicate zero ohms.

(4) Check for continuity between the WHIP ANTENNA and RECEIVER ANTENNA connectors. This should indicate zero ohms.

l. Preset the modulator controls as follows:

(1) Unlock the MODULATION control on the left side of the transmitter, and set it to the full clockwise position.

(2) Unlock the CLIPPING control, and set it to the full counterclockwise position.

(3) Unlock the SIDETONE control, and turn it to the full clockwise stop.

m. Check high-voltage operation as follows:

(1) Increase the input voltage to 29.5 ± 0.5 volts dc.

(2) Rotate the SERVICE SELECTOR switch to VOICE/FSK and the RELAY-NORMAL-DUPLEX switch to RELAY.

- (3) Rotate the preset channel switch to M (1.5 mc).
- (4) Apply 1,000-cps audio voltage to pins A and B of the AUDIO receptacle at a level which will produce a reading of -1 VU on the audio level meter. Operate the transmitter *key down* for 1 hour, then Autotune each PRESET CHANNEL to check for proper Autotune operation. The set should tune to each preset channel.

n. Check tuning capability as follows:

- (1) Rotate the SERVICE SELECTOR switch to CW and the PRESET CHANNELS switch to M (1.5 mc).
- (2) Adjust the input voltage to 28.5 volts, and unlock the BAND SELECTOR and TUNING CONTROL knobs.
- (3) Key the transmitter and rotate the TUNING CONTROL slowly through the entire band (1.5 to 1.7 mc); watch for a noticeable variation in dummy load lamp brilliance. None should be indicated if the automatic tuning system is functioning properly.
- (4) Repeat the steps outlined in (3) above for each band in the transmitter; leave the PRESET CHANNELS switch in the M position. When these tests are completed, return the BAND SELECTOR and TUNING CONTROL to 1.5 mc and lock the controls.

o. Check power output as follows:

- (1) Remove the dummy test antenna and connect one terminal of RF Ammeter IS-76 to the 50 OHMS OUTPUT connector and connect Antenna A-27 to the other terminal of the ammeter. Connect the ammeter in input circuit.
- (2) Rotate the SERVICE SELECTOR switch to CW; leave the PRESET CHANNELS switch at M (1.5 mc).
- (3) Measure the dc power input as:

$$E \times I$$

where E is input voltage (held at 28.5 volts dc)

I is measured input current.

The meter should indicate not more than 35 amperes.

- (4) Measure the rf power output as:

$$I^2 \times 50$$

where I is measured rf current. Refer to paragraph 5 for proper output.

- (5) Repeat the steps in (3) and (4) above for each of the seven preset channels. The power output should be as shown in paragraph 5.
- p. Check modulation capability as follows:
- (1) Rotate the SERVICE SELECTOR switch to the VOICE/FSK position.
 - (2) Rotate the PRESET CHANNELS switch to channel 4 (7 mc).
 - (3) Rotate the RELAY-NORMAL-DUPLEX switch to relay.
 - (4) Rotate the LINE LEVEL control to the extreme clockwise position.
 - (5) Loosely couple the rf output of the transmitter to the vertical plates of Oscilloscope OS-8/U.
 - (6) Apply .015 volt (rms) of the audio voltage (1,000 cps) to pins A and B of the AUDIO receptacle, and adjust the MODULATION control to obtain 90-percent modulation as indicated on the oscilloscope screen. Check for a reading of -1 VU on the audio meter.
 - (7) Turn the CLIPPING control on the left side of the transmitter in a clockwise direction until 80-percent modulation is indicated on the oscilloscope screen.
 - (8) Adjust the SIDETONE control to the position which provides the desired amplitude of tone.
- q. Check audio response as follows:
- (1) Set the SERVICE SELECTOR switch to VOICE/FSK and the PRESET CHANNELS switch to channel 4 (7 mc).
 - (2) Connect Spectrum Analyzer TS-723/U to the transmitter as described in the spectrum analyzer instruction manual.
 - (3) Apply 1,000-cps audio voltage to pins A and B of the AUDIO receptacle at a value which produces 80-percent modulation. Measure and record the audio input voltage, and maintain this voltage throughout this test.
 - (4) The reading obtained on the spectrum analyzer meter is the reference (considered as zero db) for all audio frequencies. Measure and record the audio level

(in db below this reference) for modulating frequencies of 300 and 3,500 cps. These should vary not more than +0.5 db and -2.5 db.

r. Audio Distortion.

- (1) With the equipment set up exactly as described in *q* above, increase the input voltage to produce 80-percent modulation.
- (2) Operate the spectrum analyzer to measure the percentage harmonic distortion at 1,000 cps. The distortion should be not more than 10 percent.

s. Audio Noise.

- (1) Set the equipment up as described in *q* above to produce 80-percent modulation.
- (2) Measure the amplitude of the audio voltage detected in the spectrum analyzer, and define this as zero db (reference).
- (3) Reduce the modulation to zero by completely disconnecting the audio oscillator; then measure audio output voltage in terms of zero db reference. This should be at least 40 db below the reference value.
- (4) Switch the SERVICE SELECTOR to CW, and again measure the audio output as in (3) above. This value also should be at least 40 db below the reference.

t. Remote Control Operation. Check remote control operation as follows:

- (1) Connect the remote control cable to the REMOTE CONTROL receptacle on the transmitter.

- (2) Connect a microphone to the AUDIO receptacle at the remote control unit.
- (3) Set the transmitter SERVICE SELECTOR switch to CALIB and the PRESET CHANNELS switch to M.
- (4) When the Autotune cycle ends, rotate the local SERVICE SELECTOR switch to REMOTE and rotate the remote SERVICE SELECTOR switch to CW.
- (5) Rotate the remote control unit PRESET CHANNELS switch to channel 1, and check for corresponding Autotune action in the transmitter.
- (6) Repeat the check given in (5) above by tuning each channel from the remote location. When channel 7 has been selected, key the transmitter remotely, and check for simultaneous operation of the remote control TUNING INDICATOR lamp and the transmitter TUNING INDICATOR lamp.
- (7) Rotate the remote control unit SERVICE SELECTOR switch to the VOICE/FSK position.
- (8) Check modulation capability by speaking into the microphone and observing a variation in the antenna current.
- (9) Connect the headphones to the remote control unit AUDIO receptacle, and check for sidetone during microphone operation.
- (10) Rotate the transmitter SERVICE SELECTOR switch to CALIB. Check to see that preset control has been transferred to the main panel.

CHAPTER 8

SHIPMENT AND LIMITED STORAGE AND DEMOLITION TO PREVENT ENEMY USE

Section I. SHIPMENT AND LIMITED STORAGE

131. Disassembly

The following instructions are recommended as a guide for preparing Radio Transmitter T-195/GRC-19 for transportation and storage.

a. Disconnect all cables, accessories, and auxiliary equipment from the front panel of the transmitter.

b. Remove the transmitter from Mounting MT-925/GRC-19 by loosening the three thumb nuts which secure the hooks at the bottom of the front panel, and pull the transmitter outward and upward.

c. Remove the top platform of the mount, then unbolt the bottom platform from the vehicle. Reassemble the mount.

132. Repacking for Shipments or Limited Storage

a. The exact procedure for repacking for shipment or limited storage depends upon the material available and the conditions under which the equipment is to be shipped or stored. In reverse

order, follow the instructions given in paragraphs 6 and 13 and figure 4.

b. When the air-intake and exhaust ports (fig. 9) are sealed, the interior of the transmitter is protected from moisture. Before shipment of the transmitter, see that these ports are closed (yellow side facing out). To close the three ports, press up the catches on each side of the ports, pull out the ports and reverse them; then secure the catches (by pressing down).

c. Whenever spare parts, cable assemblies, or accessory or auxiliary equipment are to be shipped or stored, a dehydrating agent such as silica gel should be placed inside the container. If the original packing material and containers are not available, wrap the equipment in corrugated paper, and protect each package with a waterproof barrier. Seal the seams of the paper barrier with waterproof sealing compound or tape. Pack the protected component in a padded wooden case; provide at least 3 inches of excelsior or some similar material between the paper barrier and the packing case.

Section II. DEMOLITION OF MATERIEL TO PREVENT ENEMY USE

133. General

The demolition procedures outlined in paragraph 134 will be used to prevent the enemy from using or salvaging this equipment. Demolition of the equipment will be accomplished only on order of the unit commander.

134. Methods of Destruction

a. Smash. Smash the controls, tubes, crystals, transformers, capacitors, switches, and tuning mechanism; use sledges, axes, pickaxes, hammers, crowbars, or other heavy tools.

b. Cut. Cut all internal and external cords, cables and wiring; use axes, handaxes, or machetes.

c. Burn. Burn cords, resistors, capacitors, coils, wiring, and manuals; use gasoline, kerosene, oil, flame throwers, or incendiary grenades.

d. Bend. Bend dials, case, and chassis.

e. Explosives. If explosives are necessary, use grenades or TNT.

f. Disposal. Bury or scatter the destroyed parts in slit trenches, fox holes or other holes, or throw them into streams.

g. Destroy. Destroy everything.

RESISTOR COLOR CODE MARKING (MIL-STD RESISTORS)

AXIAL-LEAD RESISTORS (INSULATED)

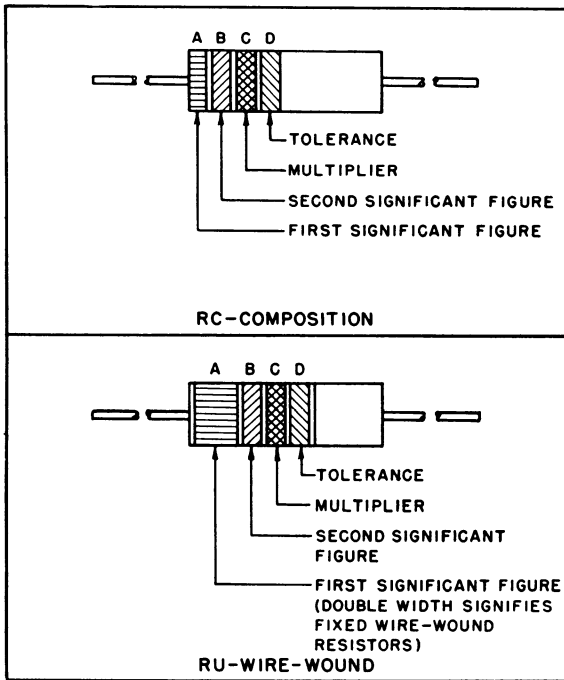

RADIAL-LEAD RESISTORS (UNINSULATED)

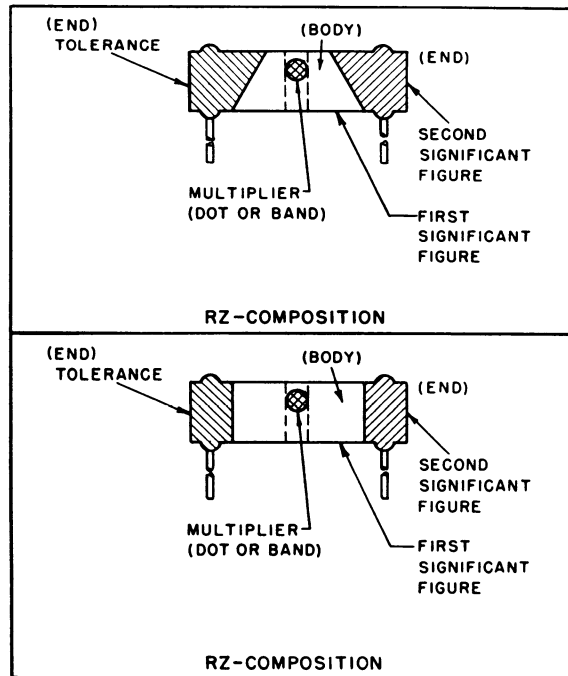

RESISTOR COLOR CODE

BAND A OR BODY*		BAND B OR END*		BAND C OR DOT OR BAND*		BAND D OR END*	
COLOR	FIRST SIGNIFICANT FIGURE	COLOR	SECOND SIGNIFICANT FIGURE	COLOR	MULTIPLIER	COLOR	RESISTANCE TOLERANCE (PERCENT)
BLACK	0	BLACK	0	BLACK	1	BODY	± 20
BROWN	1	BROWN	1	BROWN	10	SILVER	± 10
RED	2	RED	2	RED	100	GOLD	± 5
ORANGE	3	ORANGE	3	ORANGE	1,000		
YELLOW	4	YELLOW	4	YELLOW	10,000		
GREEN	5	GREEN	5	GREEN	100,000		
BLUE	6	BLUE	6	BLUE	1,000,000		
PURPLE (VIOLET)	7	PURPLE (VIOLET)	7				
GRAY	8	GRAY	8	GOLD	0.1		
WHITE	9	WHITE	9	SILVER	0.01		

* FOR WIRE-WOUND-TYPE RESISTORS, BAND A SHALL BE DOUBLE-WIDTH. WHEN BODY COLOR IS THE SAME AS THE DOT (OR BAND) OR END COLOR, THE COLORS ARE DIFFERENTIATED BY SHADE, GLOSS, OR OTHER MEANS.

EXAMPLES (BAND MARKING):

10 OHMS ± 20 PERCENT: BROWN BAND A; BLACK BAND B; BLACK BAND C; NO BAND D.
4.7 OHMS ± 5 PERCENT: YELLOW BAND A; PURPLE BAND B; GOLD BAND C; GOLD BAND D.

EXAMPLES (BODY MARKING):

10 OHMS ± 20 PERCENT: BROWN BODY; BLACK END; BLACK DOT OR BAND; BODY COLOR ON TOLERANCE END.
3,000 OHMS ± 10 PERCENT: ORANGE BODY; BLACK END; RED DOT OR BAND; SILVER END.

STD-R1

Figure 127. Resistor color codes.

CAPACITOR COLOR CODE MARKING (MIL-STD CAPACITORS)

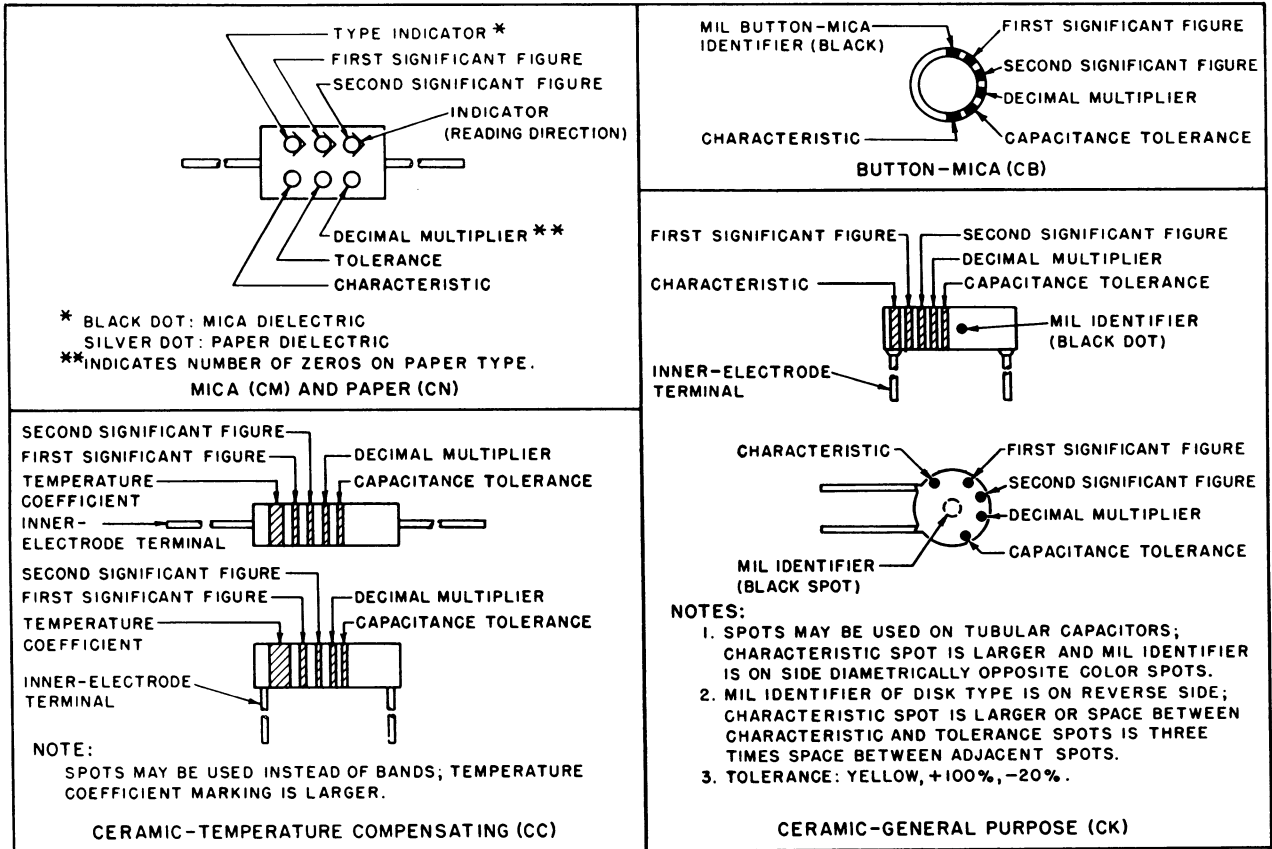

CAPACITOR COLOR CODE

COLOR	SIG FIG.	MULTIPLIER		CHARACTERISTIC ¹				TOLERANCE ²					TEMPERATURE COEFFICIENT (UUF/UF/°C)
		DECIMAL	NUMBER OF ZEROS	CM	CN	CB	CK	CM	CN	CB	CC		
											OVER 10UUF	10UUF OR LESS	
BLACK	0	1	NONE		A			20	20	20	20	2	ZERO
BROWN	1	10	1	B	E	B	W				1		-30
RED	2	100	2	C	H		X	2		2	2		-80
ORANGE	3	1,000	3	D	J	D			30				-150
YELLOW	4	10,000	4	E	P								-220
GREEN	5		5	F	R						5	0.5	-330
BLUE	6		6		S								-470
PURPLE (VIOLET)	7		7		T	W							-750
GRAY	8		8			X						0.25	+30
WHITE	9		9								10	1	-330(±500) ³
GOLD		0.1						5		5			+100
SILVER		0.01						10	10	10			

1. LETTERS ARE IN TYPE DESIGNATIONS GIVEN IN MIL-C SPECIFICATIONS.
2. IN PERCENT, EXCEPT IN UUF FOR CC-TYPE CAPACITORS OF 10 UUF OR LESS.
3. INTENDED FOR USE IN CIRCUITS NOT REQUIRING COMPENSATION.

STD-CI

Figure 128. Capacitor color codes.

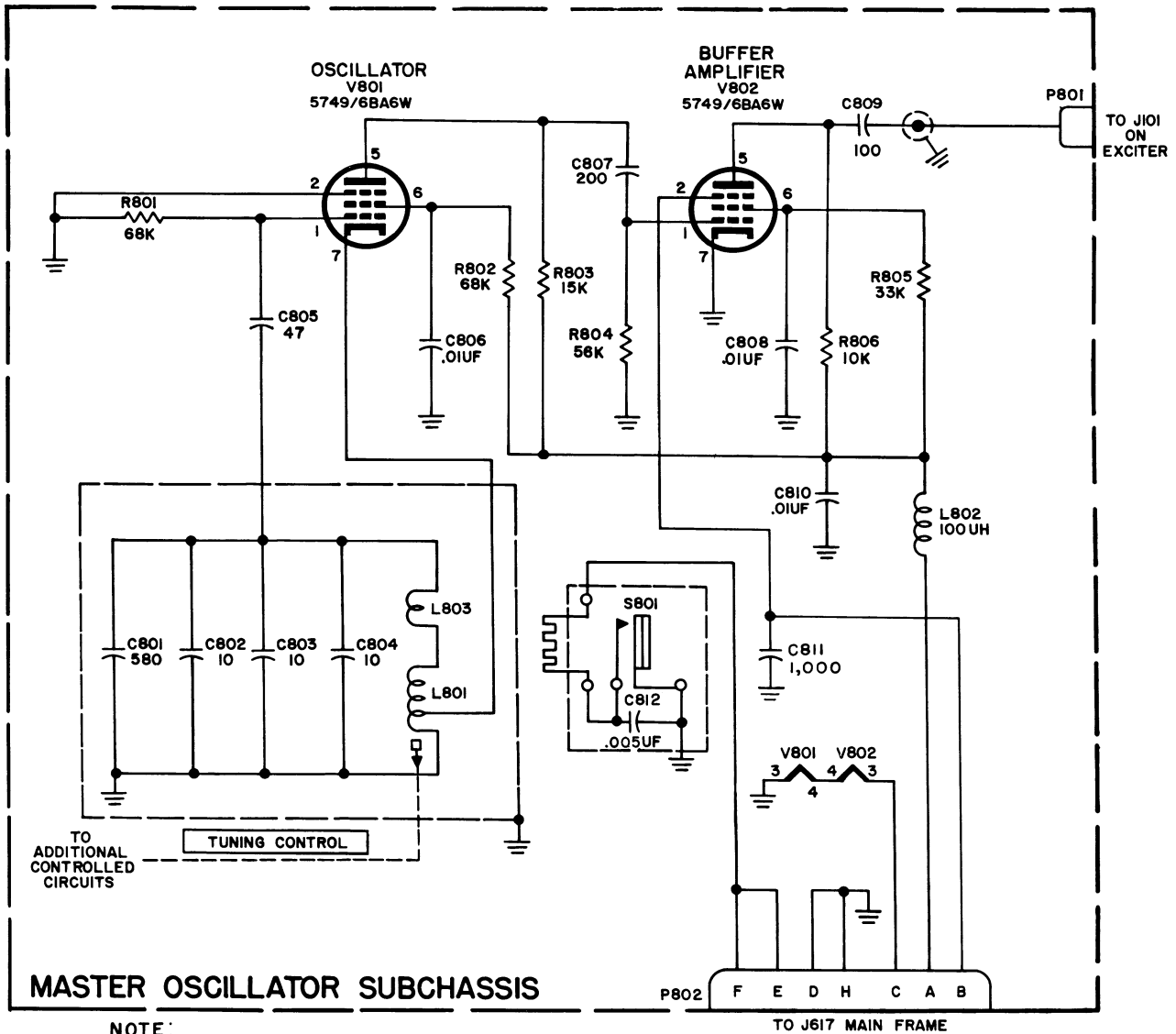
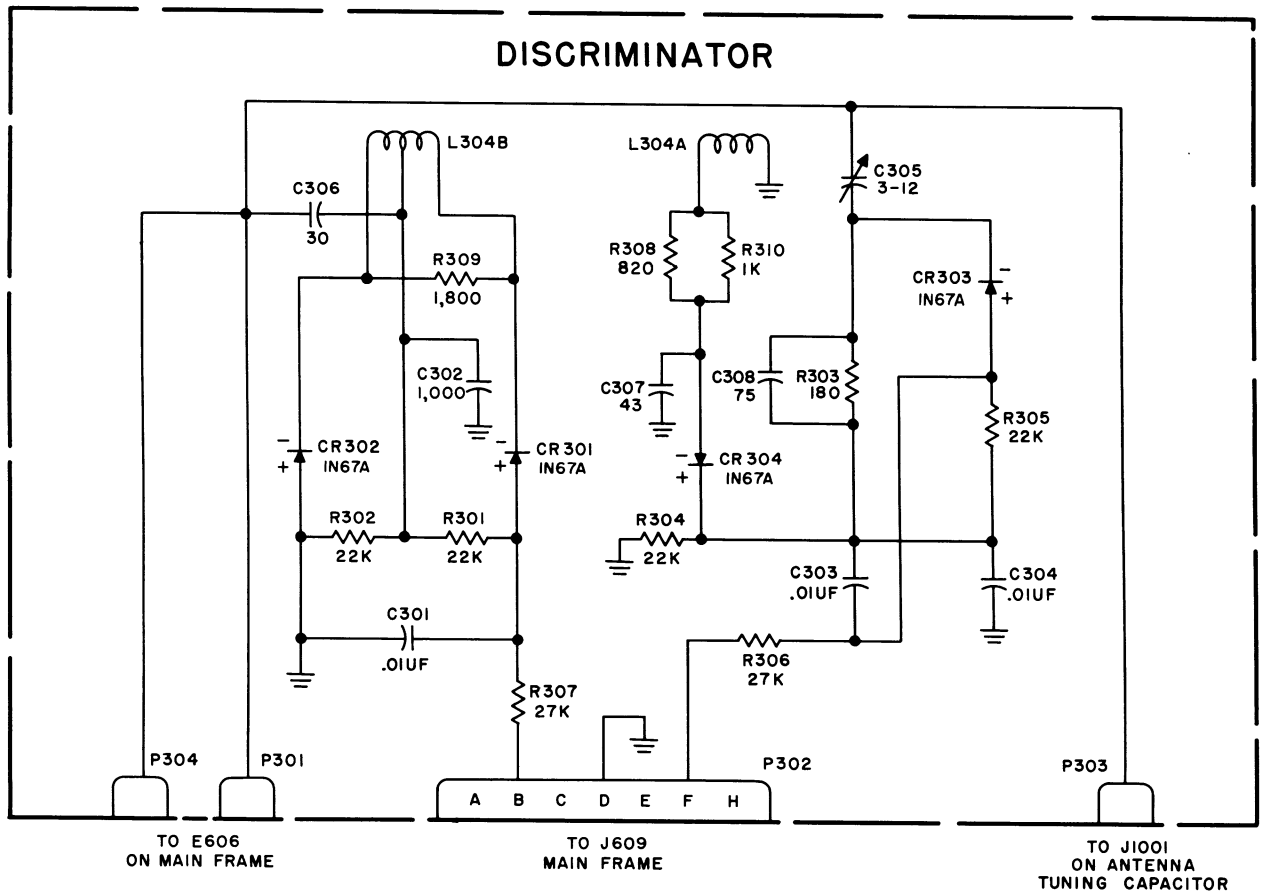

Figure 129. Master oscillator subchassis, schematic diagram.

TM806-132



TM806-129

Figure 133. Discriminator subchassis, schematic diagram.

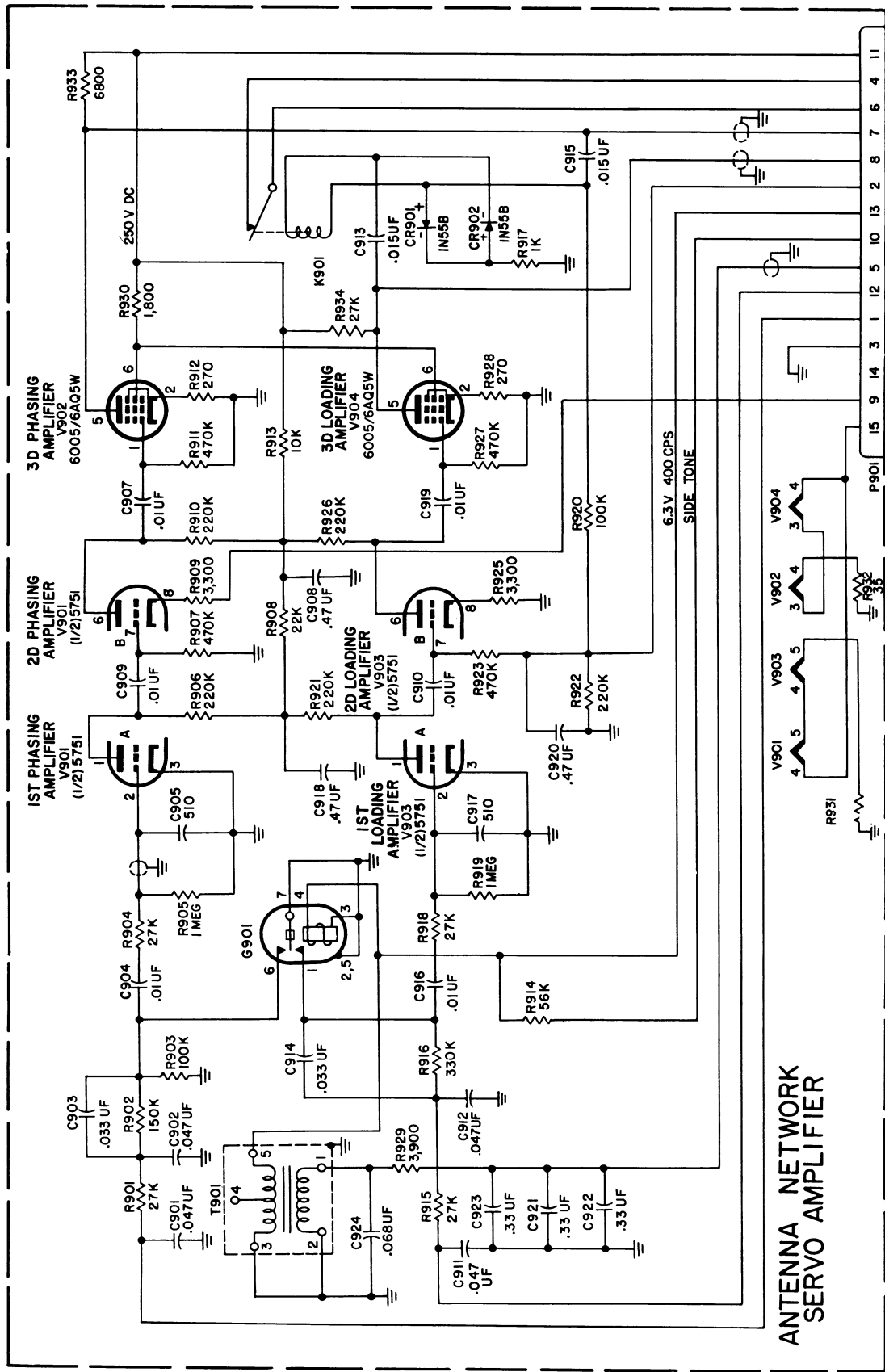

Figure 134. Antenna network servo amplifier subchassis, schematic diagram.

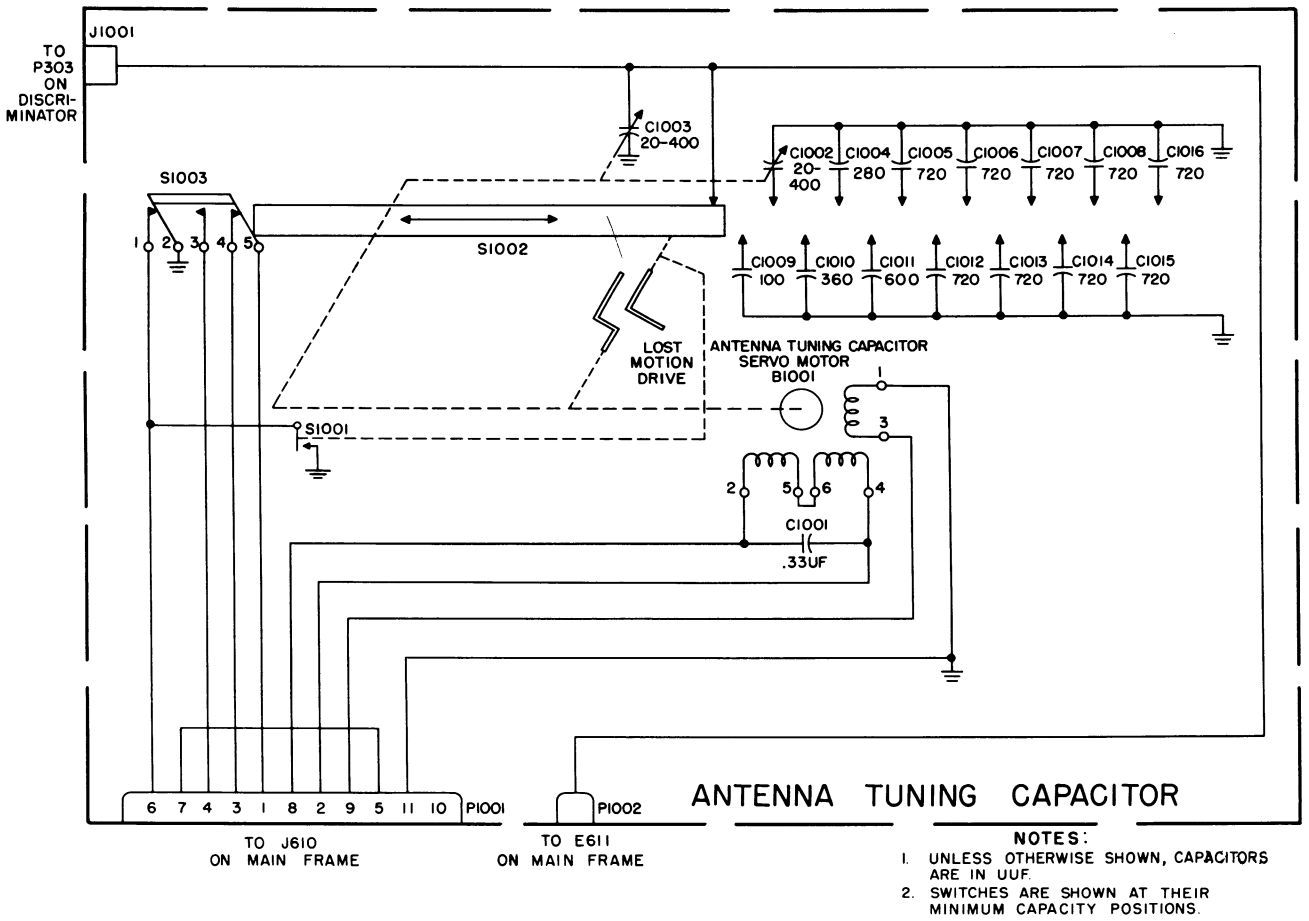
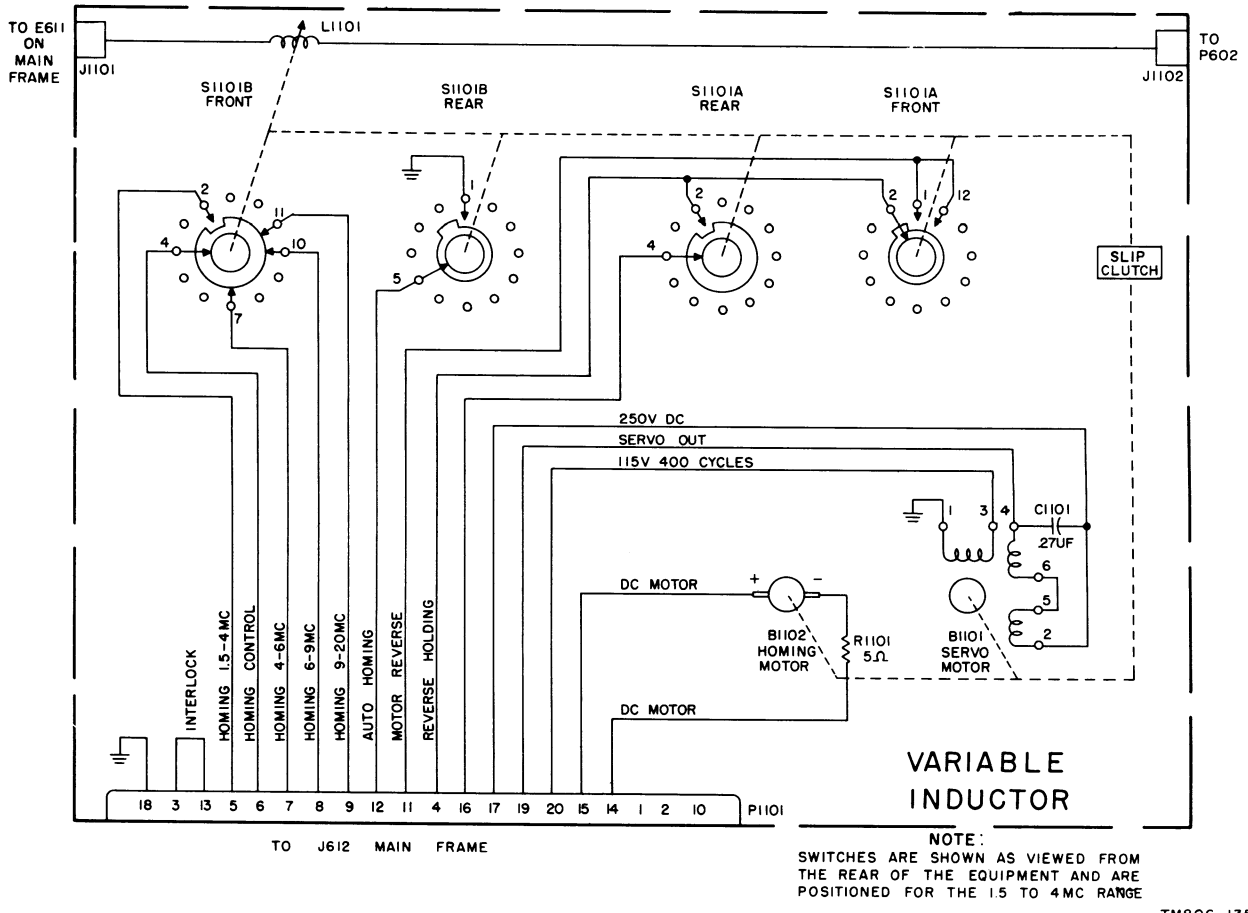

Figure 135. Antenna tuning capacitor subchassis, schematic diagram.



TM806-135

Figure 136. Variable inductor subchassis, schematic diagram.

APPENDIX

GLOSSARY OF TERMS

Autotune—The name applied to an electromechanical system which automatically positions a shaft to a predetermined setting.

Control head—The electrical part of an Autotune system which controls the positioning heads.

Frequency-shift keying—Method of keying a receiving teletypewriter by shifting the transmitted carrier frequency to a slightly different value.

Home position—That position to which a variable circuit component always is returned, before adjustment to a new position.

Homing—Positioning of circuit parts before final adjustment.

Multiturn positioning head—A mechanical part of an Autotune system which will rotate a shaft

several times, if necessary, to a predetermined position.

Servo—The name applied to a power-amplifying system which will position a shaft according to the polarity and amplitude of a correction voltage.

Sidetone—Audio signal used for monitoring transmissions.

Singleturn positioning head—A mechanical part of an Autotune system which will rotate a shaft one complete revolution, if necessary, to a predetermined position.

Subchassis—The name applied to a removable assembly which performs a major function in the transmitter.

1

2

INDEX

	Paragraph	Page		Paragraph	Page
Additional equipment:			Autotune system—Continued		
Connection of.....	15d	12	Theory—Continued		
List of.....	11	8	Multiturn head.....	85	84
Air filter maintenance.....	34a(12)	24	Singleturn head.....	84	82
Alinement and/or adjustment:			Auxiliary equipment:		
Antenna tuning capacitor.....	123	172	Electrical Special Purpose Cable As-		
Autotune mechanism.....	114	165	sembly		
Dial zero.....	21	17	CX-2585/U.....	43	33
Discriminator subchassis.....	119	168	Mounting		
Exciter subchassis.....	116, 118	166, 168	MT-925/GRC-19.....	48	39
Frequency indicator assembly.....	122	171	Transmitter Control C-882/GRC-19:		
Master-oscillator subchassis.....	120	170	Circuit description of.....	46	34
Modulator subchassis.....	115	166	Connections to.....	44	33
Power-amplifier subchassis.....	117	167	Description of.....	42	33
Speed regulator.....	121	170	Maintenance of.....	47	39
Test equipment and tools for.....	113	165	Operation of.....	45	33
Variable inductor subchassis.....	124	172	Band switch synchronization:		
Antenna:			Exciter subchassis.....	116	166
Connection.....	15b	12	Power-amplifier subchassis.....	117	167
Dummy load.....	99c	97	Bench testing.....	97	96
Installation.....	14c	12	Calibration:		
Theory of antenna tuning:			Master-oscillator subchassis.....	120	170
Block diagram.....	74	65	Radio Transmitter T-195/GRC-19..	21	17
Homing circuits.....	75	67	Cleaning:		
Network discriminator.....	76	69	Air filter.....	34	23
Output capacitor.....	78	77	Before lubrication.....	110a	159
Purpose of.....	73	63	Components, table of.....	7	5
Servo amplifier.....	77	73	Connections:		
Transmitter output circuits.....	73	63	Accessory.....	15	12
Antenna-network servo-amplifier subchas-			Antenna.....	15	12
sis:			Auxiliary.....	15	12
Removal and replacement of.....	108	144	Ground.....	15	12
Theory of.....	77	73	Power input.....	15	12
Antenna switching and keying circuits:			Controls, function of.....	18	13
Circuit analysis.....	81	78	Crystal testing.....	107	144
Flow chart.....	80	78	Dc resistance of transformer, coils, and		
Antenna tuning capacitor subchassis:			motors.....	105	141
Adjustment of.....	123	172	Demolition procedure.....	133	177
Removal of.....	108	144	Dial calibration.....	21	17
Replacement of.....	108	144	Discriminator, removal and replacement..	108	144
Synchronization of.....	123	172	Dynamotors:		
Theory of.....	73	63	Brush removal.....	108	144
Autotune system:			Lubrication of.....	110	159
Disassembly and reassembly of.....	109	153	Removal of.....	108	144
Final test.....	130	174	Replacement of.....	108	144
Lubrication.....	110b	163	Speed regulator.....	121	170
Removal and replacement:			Equipment performance check list.....	41	29
Control head.....	108	144	Exciter subchassis:		
Multiturn positioning head.....	108	144	Alinement of.....	118	168
Singleturn positioning head.....	108	144	Removal of.....	108	144
Synchronization of.....	114	165	Replacement of.....	108	144
Theory:			Synchronization of.....	116	166
Control circuit.....	83	81			
General analysis.....	82	81			

Exciter subchassis—Continued			Network discriminator subchassis:		
	Paragraph	Page		Paragraph	Page
Theory:			Adjustment and testing of..... 119 168		
Block diagram.....	55	43	Removal and replacement of..... 108 144		
Driver V104.....	59	47	Theory of..... 76 69		
First multiplier V101.....	56	43	Operational tests..... 41 29		
Neutralization.....	60	49	Operating procedure:		
Second multiplier V102.....	57	45	Arctic climate..... 26 20		
Third multiplier.....	58	45	Combined fsk and voice..... 23a 19		
Tuned circuits, removal of.....	108	144	Desert climate..... 28 21		
Final testing:			Dial zero adjustment..... 21 17		
Audio performance.....	130	174	Fsk..... 4c 4		
Autotune mechanism.....	130	174	Presetting..... 20 17		
Power output.....	130	174	Starting..... 22 18		
Forms and records.....	2	3	Stopping..... 24 20		
Frequency indicator assembly:			Tropical climate..... 27 20		
Adjustment of.....	122	171	Voice..... 23 19		
Lubrication of.....	110	159	Output capacitor..... 78 77		
Removal of.....	108	144	Packaging data..... 6 5		
Replacement of.....	108	144	Power amplifier subchassis:		
Front panel:			Removal and replacement of..... 108q 48		
Controls and connections.....	18	13	Synchronization of..... 117 67		
Removal of.....	108	144	Theory:		
Replacement of.....	108	144	Automatic tuning..... 64 52		
Fsk radioteletype.....	4	4	Block diagram..... 61 49		
Fuses, checking.....	101	99	Clamper V202..... 63 52		
Homing circuits.....	75	67	Power amplifier V201..... 62 51		
Inspection, visual.....	39, 100	25, 97	Power distribution circuits:		
Keying circuits:			24 volts dc..... 88 87		
Circuit theory.....	81	78	--45 volts dc..... 91 92		
Flow chart.....	80	78	250 volts dc..... 90 92		
Keying relay K605.....	81	78	1,000 volts dc..... 92 92		
Lubrication.....	110	159	115 volts, 400 cps..... 89 91		
Master-oscillator subchassis:			Presetting:		
Alinement and calibration of.....	120	170	Frequency channels..... 20 17		
Removal of.....	108	144	Preventive maintenance:		
Replacement of.....	108	144	Definition of..... 31 22		
Theory:			Form..... 33 23		
Block diagram.....	51	41	Performing..... 34 23		
Buffer amplifier V802.....	53	42	Techniques..... 32 22		
Frequency stabilization.....	54	42	Radio Set AN/GRC-19..... 4 4		
Oscillator V801.....	52	41	Radio Transmitter T-195/GRC-19:		
Modulator subchassis:			Additional equipment for..... 11 8		
Adjustment of.....	115	166	Block diagram..... 50 40		
Removal and replacement.....	108	144	Calibration of..... 21 17		
Theory:			Description of..... 8 6		
Block diagram.....	65	57	Installation of..... 14 11		
First audio amplifier V401B.....	68	60	Operation:		
Limiter V402.....	67	59	Arctic climate..... 26 20		
Modulator tubes V406 and V407.....	71	61	Desert climate..... 28 21		
Phase inverter V404B.....	70	61	Tropical climate..... 27 20		
Preamplifier V401A.....	66	57	Types of..... 23 19		
Second audio amplifier V404A.....	69	61	Performance check list..... 41 29		
Sidetone amplifier V403B.....	72	62	Presetting..... 20 17		
Motors and dynamotors:			Purpose of..... 3 3		
Brush removal and replacement.....	108	144	Starting procedure..... 22 18		
Lubrication of dynamotors.....	110	159	Stopping procedure..... 24 20		
Removal of.....	108	144	System application..... 4 4		
Replacement of.....	108	144	Technical characteristics..... 5 4		
Mounting MT-925/GRC-19:			Tests. (See Final testing.)		
Description of.....	48	39	Trouble chart..... 103 103		
Installation of.....	14b	12	Reconditioned equipment, service of..... 16 13		
			Refinishing..... 37 26		

	Paragraph	Page		Paragraph	Page
Removals and replacements.....	108	144	Transmitter Control C-822/GRC-19—Con.		
Reshipment or storage:			Description of.....	42	33
Disassembly.....	131	177	Maintenance of.....	47	39
Repacking.....	132	177	Operation of.....	45	33
Running spares.....	10	7	Remote control cable.....	43	33
Rustproofing and painting.....	37	26	Troubleshooting:		
Servo motors, theory of.....	93	92	Bench tests.....	97	96
Sidetone.....	72	62	Chart.....	103	103
Siting.....	12	9	Crystals.....	107	144
Special tools supplied.....	30	22	Data list.....	95	96
Starting procedure.....	22	18	Dc circuits.....	101	99
Stopping procedure.....	24	20	Equipment performance.....	41	29
Synchronization:			Filament circuits.....	39	26
Antenna tuning capacitor.....	123	172	Notes.....	99	97
Autotune mechanism.....	114	165	Operational tests.....	102	103
Exciter subchassis.....	116, 118	166, 168	Precautions.....	98	97
Power-amplifier subchassis.....	117	167	Procedure.....	94	95
System:			Resistance measurements at recep-		
Application for—			tacles and connectors.....	106	141
Fsk.....	4	4	Test equipment and tools.....	96	96
Radio Set AN/GRC-19.....	4	4	Transformers, coils, and motors.....	105	141
Technical characteristics.....	5	4	Visual inspection.....	39, 100	26, 97
Test equipment for field maintenance.....	96	96	Voltage and resistance.....	104	134
Testing:			Tuning, summary of.....	86	85
Bench.....	97	96	Uncrating, unpacking, and checking new		
Crystals.....	107	144	equipment.....	13	9
Final.....	130	174	Unsatisfactory equipment report.....	2	3
Network discriminator.....	119	168	Used or reconditioned equipment, service		
Speed regulator.....	121	170	of.....	16	13
Test equipment for—			Variable inductor subchassis:		
Alinement and adjustment.....	113	165	Removal and replacement.....	108	144
Final testing.....	127	173	Ribbon removal and replacement.....	108	144
Troubleshooting.....	96	96	Synchronization of.....	124	172
Tools and materials for:			Theory of.....	73	63
Alinement and adjustment.....	113	165	Visual inspection.....	39, 100	26, 97
Field maintenance.....	96	96	Voltage and resistance checks.....	104	134
Organizational maintenance.....	29	22	Weatherproofing.....	36	25
Transmitter Control C-822/GRC-19:			Zero dial adjustment.....	21	17
Circuit description of.....	46	34			
Connections to.....	44	33			

[AG 413.44 (13 Jun 56)]

BY ORDER OF THE SECRETARIES OF THE ARMY AND THE AIR FORCE :

MAXWELL D. TAYLOR,
General, United States Army,
Chief of Staff.

OFFICIAL :

JOHN A. KLEIN,
Major General, United States Army,
The Adjutant General.

OFFICIAL :

E. E. TORO,
Colonel, United States Air Force,
Air Adjutant General,

N. F. TWINING,
Chief of Staff, United States Air Force.

Distribution :

Active Army :

CNBG (1)	Sig Depots (17)	6-101C (2)	11-557C (2)
ASA (3)	POE (OS) (2)	6-125C (2)	11-587R (2)
Tec Svc, DA	Trans Terminal	6-126C (2)	11-592R (2)
(1) except	Comd (2)	6-135C (2)	11-597R (2)
CSIGO (30)	Army Termi-	6-136C (2)	17R (2)
Tec Svc Bd (1)	nals (2)	6-200C (2)	17-22R (2)
Hq CONARC	OS Sup Agen-	6-301C (2)	17-25C (2)
(5)	cies (2)	6-326C (2)	17-26C (2)
CONARC Bd	Army Elct PG	6-401C (2)	17-35C (2)
(incl ea Test	(1)	6-415R (2)	17-36C (2)
Sec) (1)	Sig Fld Maint	6-416R (2)	17-45C (2)
Army AA Comd	Shops (3)	6-501C (2)	17-46C (2)
(2)	Sig Lab (5)	6-515R (2)	17-57C (2)
OS Maj Comd	ACS (3)	6-525C (2)	32-55R (2)
(5)	Mil Dist (1)	6-535R (2)	32-56R (2)
OS Base Comd	Units organized	6-536R (2)	32-57R (2)
(5)	under fol-	6-537R (2)	32-500R (2)
Log Comd (5)	lowing	6-545C (2)	44-12R (2)
Sp Wpn Comd	TOE's:	6-575C (2)	44-15R (2)
(2)	5-15C (2)	6-576C (2)	44-16R (2)
MDW (1)	5-16C (2)	6-577C (2)	44-17R (2)
Armies (5)	5-17C (2)	6-626C (2)	44-35R (2)
Corps (2)	5-35R (2)	7R (2)	44-36R (2)
Ft & Cp (2)	5-36R (2)	7-1R (2)	44-37R (2)
Tng Cen (2)	5-37R (2)	7-15R (2)	44-75C (2)
Army Cml Cen	5-137C (2)	7-16R (2)	44-76C (2)
(4)	5-138C (2)	7-25R (2)	44-101R (2)
Gen & Br Svc	5-192C (2)	7-26R (2)	44-145R (2)
Sch (5) ex-	5-215R (2)	11-7C (2)	44-146R (2)
cept Sig Sch	5-216R (2)	11-15C (2)	44-147R (2)
(25)	5-217R (2)	11-16C (2)	44-275C (2)
Gen Depot (2)	5-218R (2)	11-18C (2)	44-276C (2)
except Atlan-	5-312R (2)	11-57C (2)	44-277C (2)
ta Gen Depot	5-316R (2)	11-127R (2)	44-335C (2)
(none)	5-317R (2)	11-128R (2)	44-336C (2)
Sig Sec, Gen	5-367C (2)	11-500R	44-337C (2)
Depots (10)	6-100C (2)	(AA-AE)	57C (2)
		(2)	

NG: State AG (6) ; units—same as Active Army except allowance is one copy to each unit.

USAR: None.

For explanation of abbreviations used, see SR 320-50-1.

1

2
3

4
5

Handwritten marks and scribbles along the right edge of the page, including a vertical line and some illegible characters.



TM 11-806/TO 31R2-2000-11-11-RADIO TRANSMITTER T-195/GRC-19

TM 11-806/TO 31R2-2 GRC 19-11

FIGURES

20
30
31
44
45
52
54
55

115
130
131
132
137
138
139

57
58
61
63
104
105
118
114

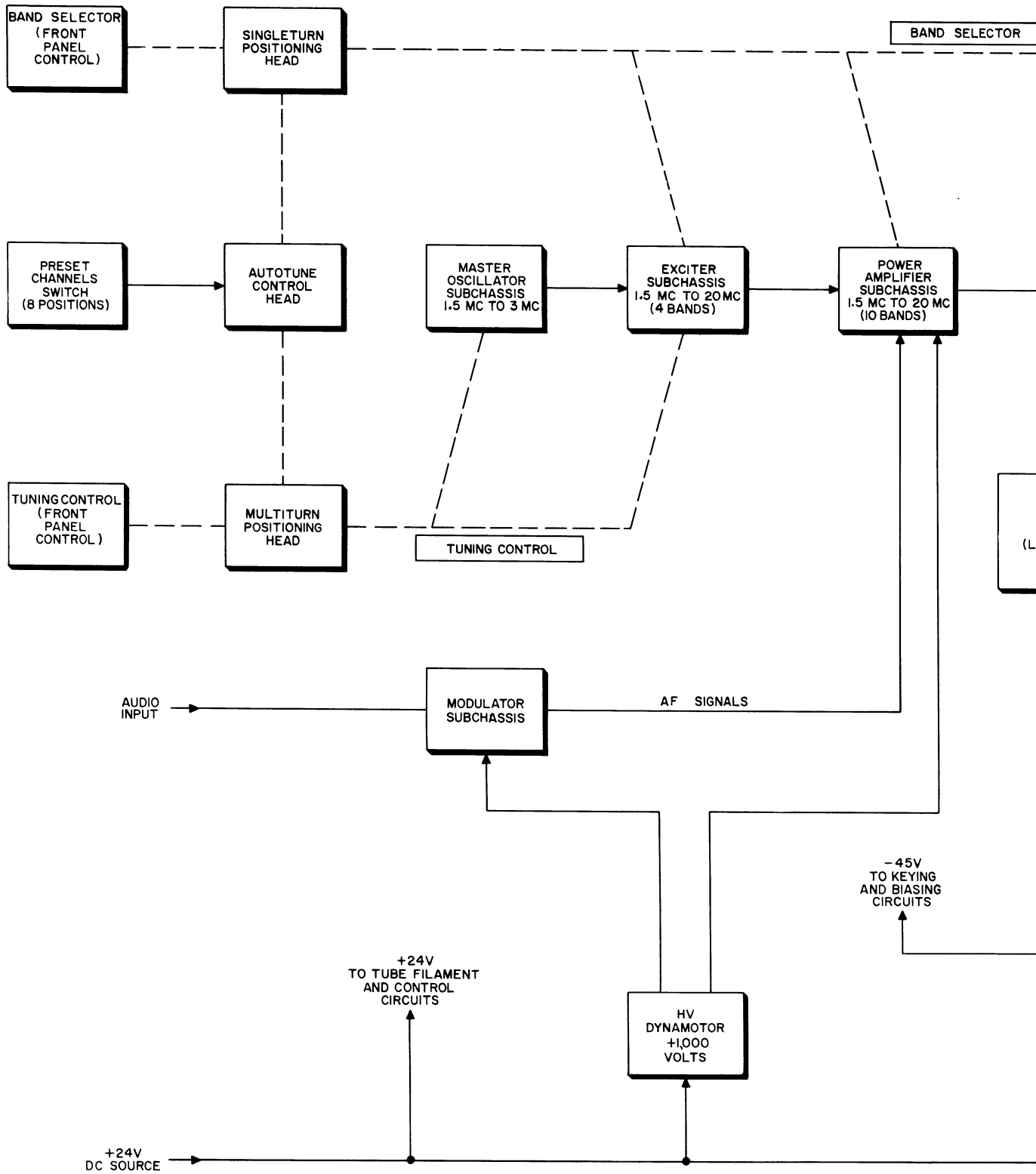

Figure 20. Radio Trans

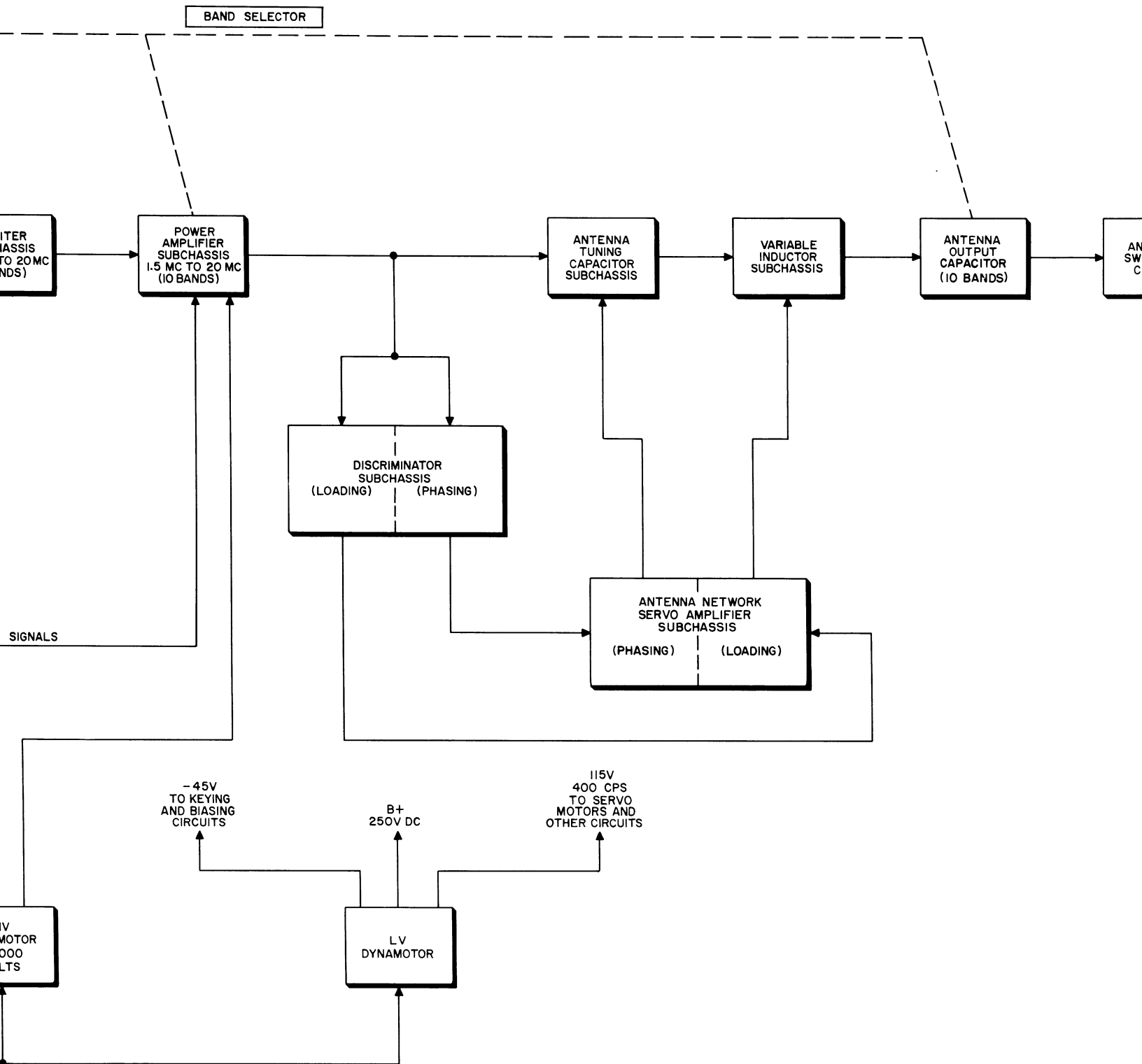
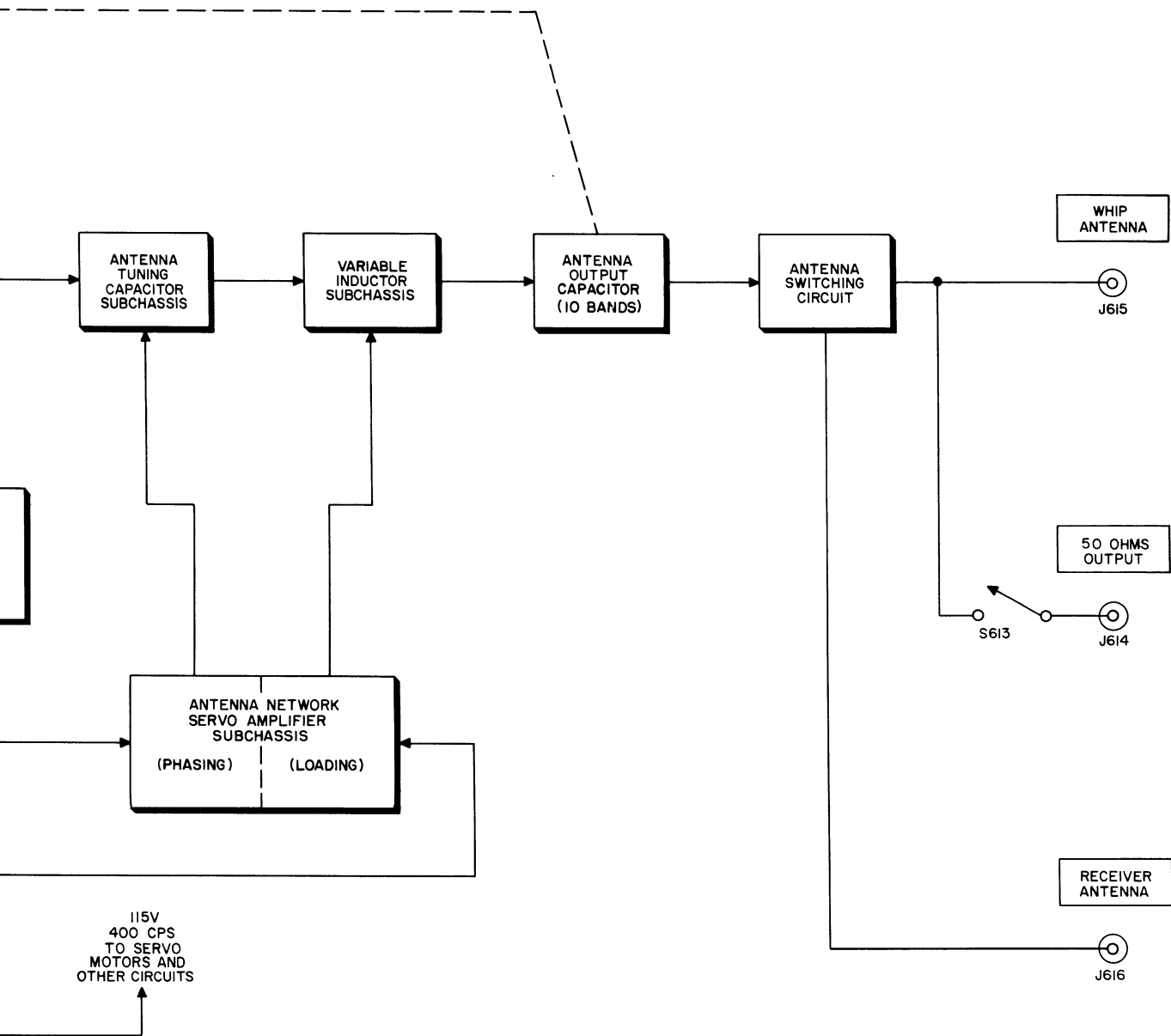

Figure 20. Radio Transmitter T-195/GRC-19, composite block diagram.



9, composite block diagram.

TM806-21

390412 O -56 (In pocket) No. 1

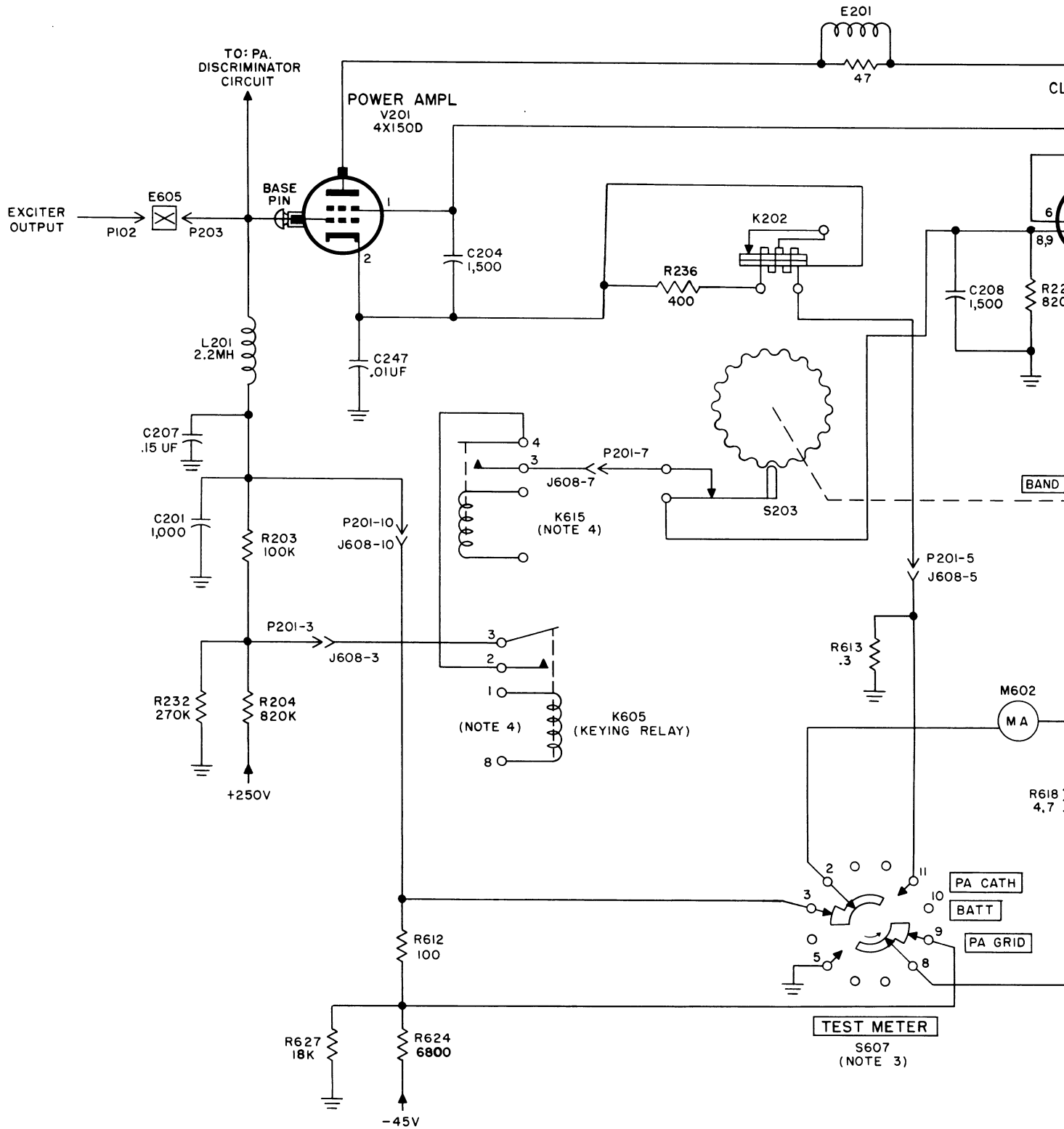
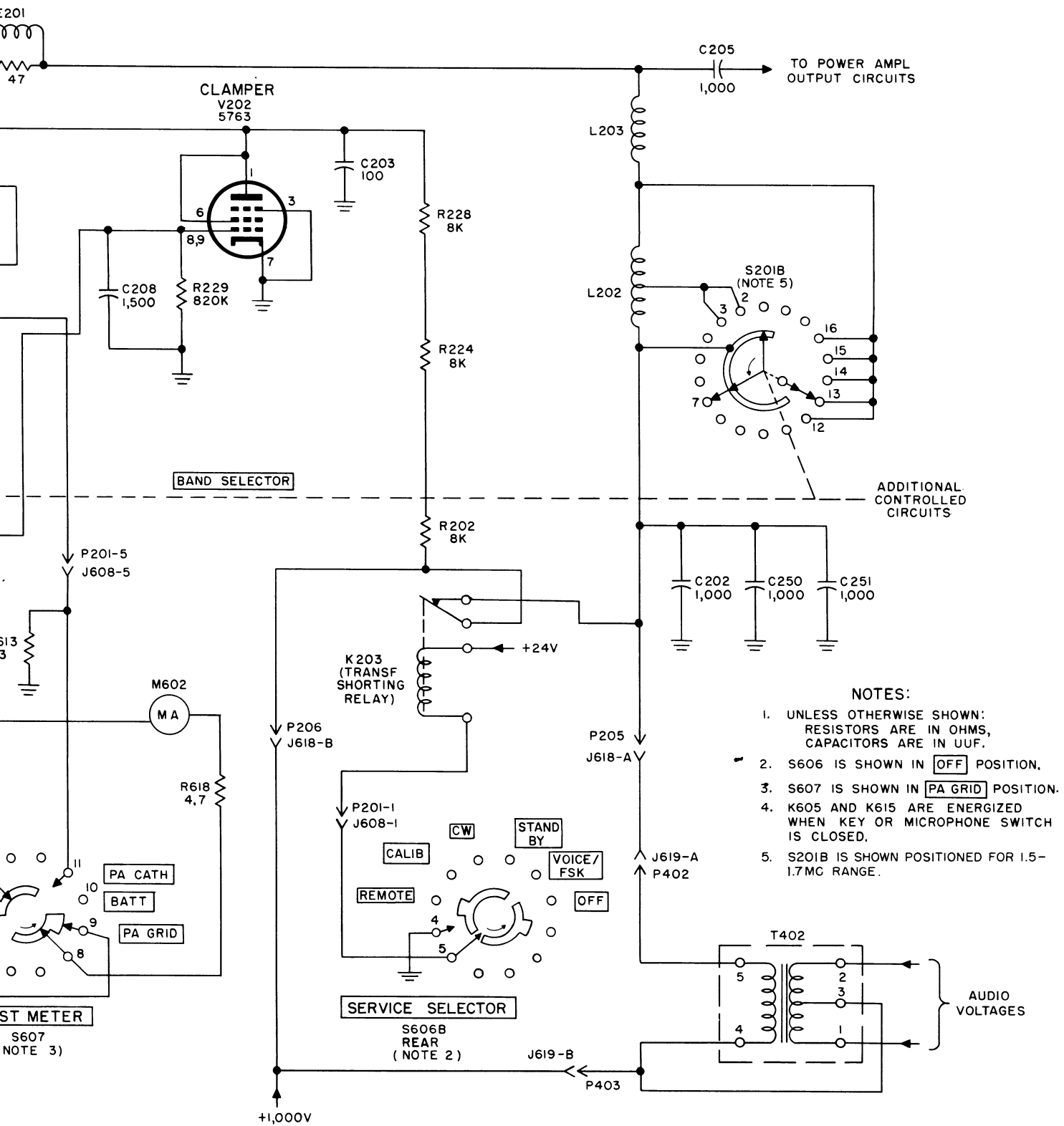

Figure 30. Power-amplifier and clamber stage



Amplifier and clamber stages, functional diagram.

TM 806-31

390412 O -56 (In pocket) No. 2

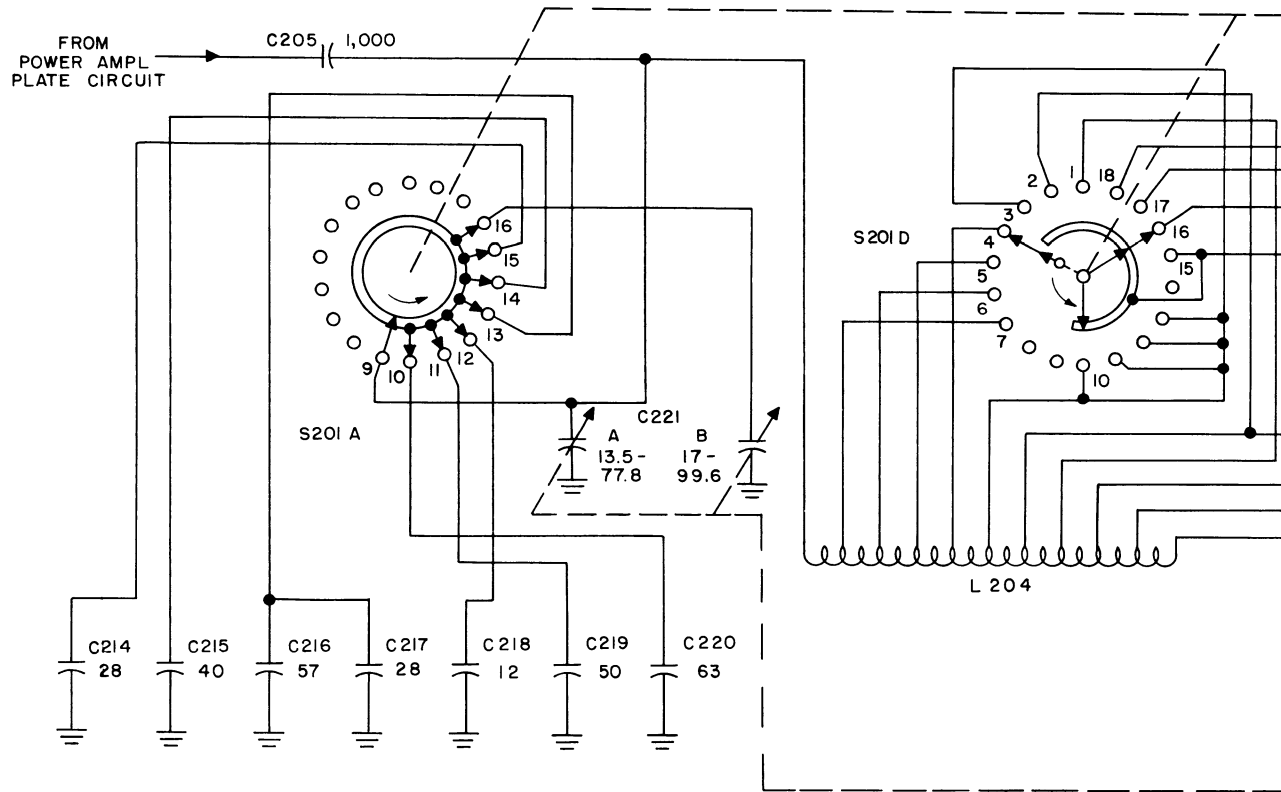

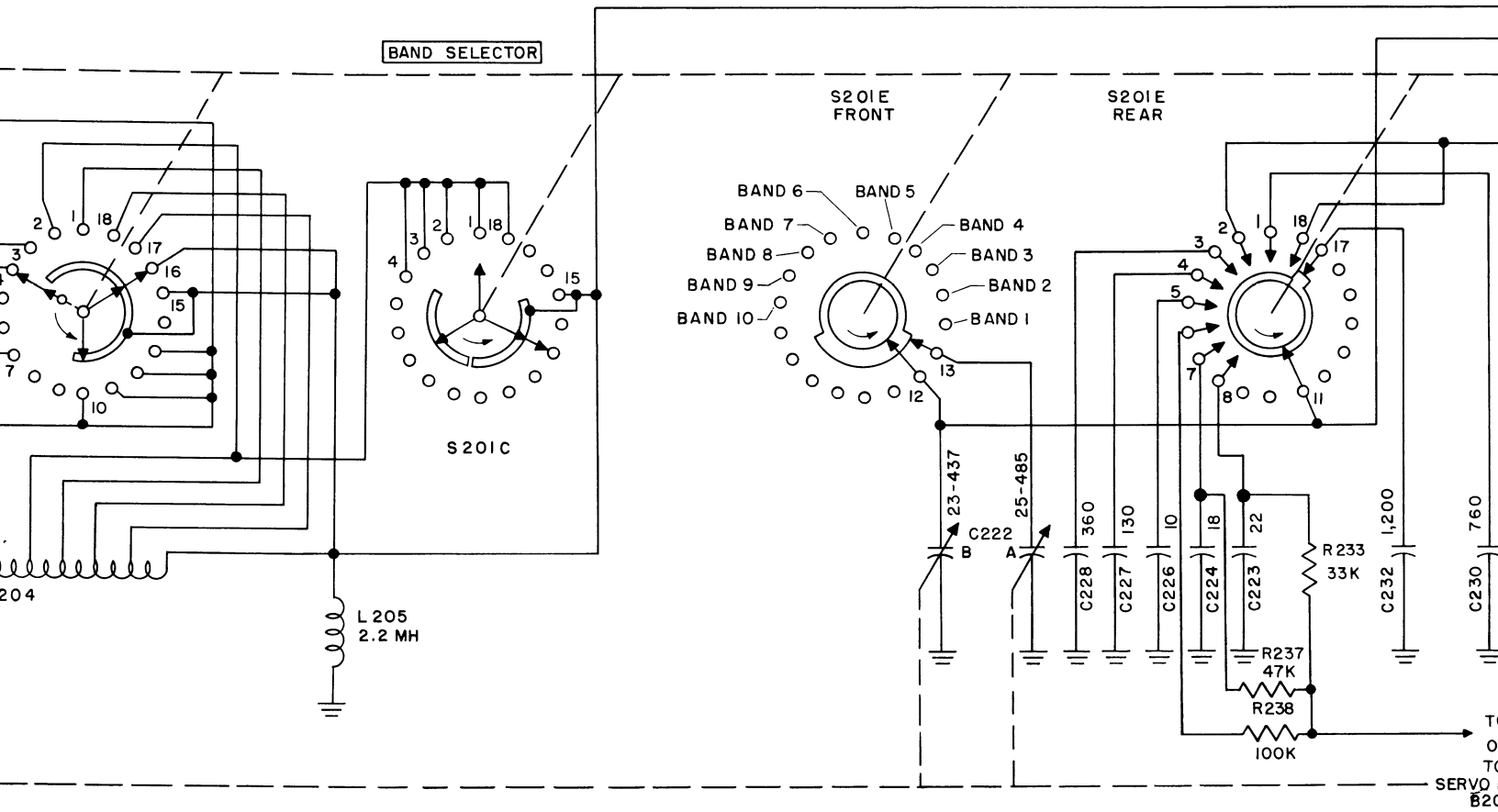
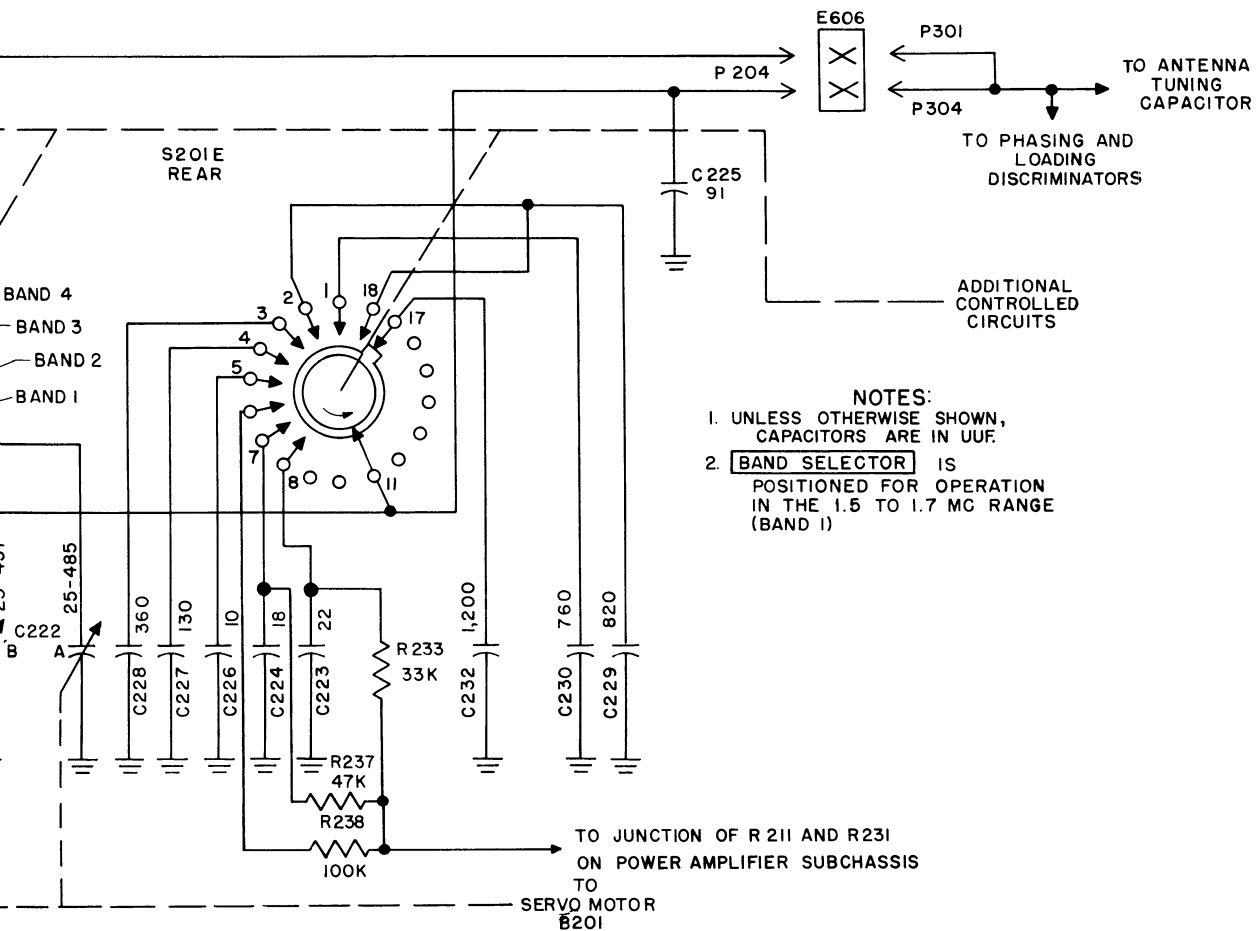

Figure 31. Power-amplifier plate circuit, functional diagram.



TM 806-32

390412 O - 56 (In pocket) No. 3

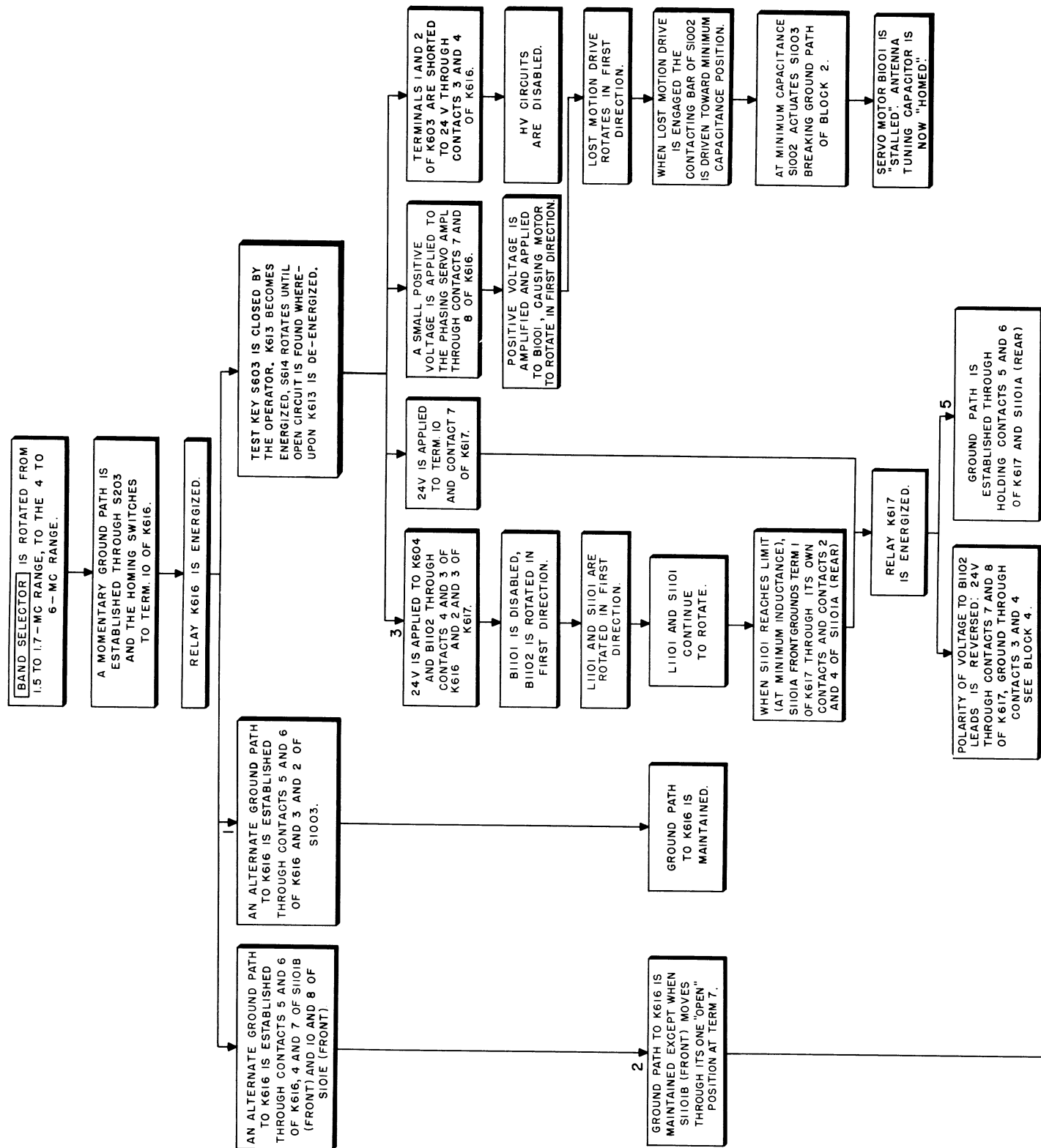

Figure 44. Homing cycle flow chart.

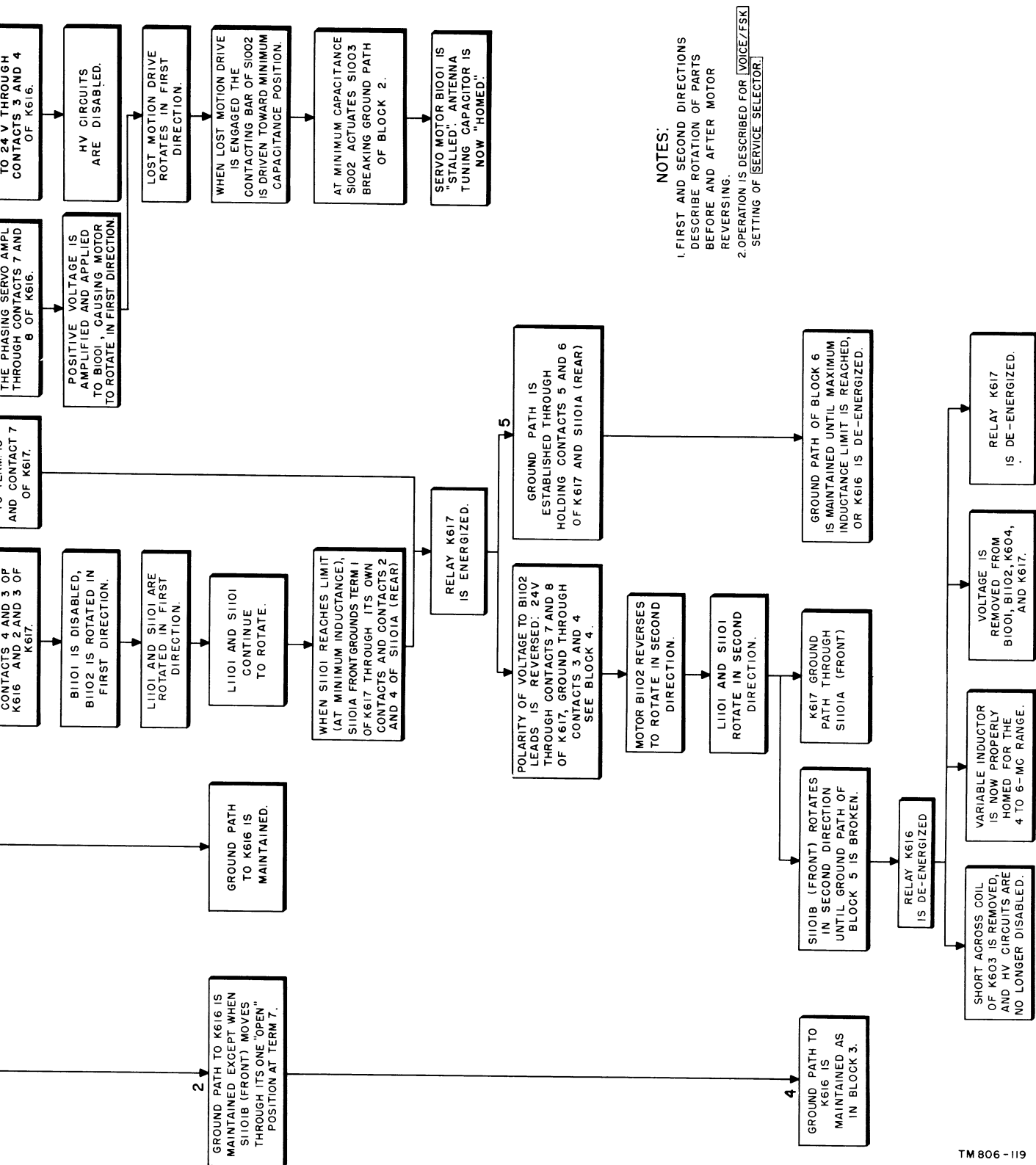

Figure 44. Homing cycle flow chart.

NOTES:
 1. FIRST AND SECOND DIRECTIONS DESCRIBE ROTATION OF PARTS BEFORE AND AFTER MOTOR REVERSING.
 2. OPERATION IS DESCRIBED FOR VOICE/FSK SETTING OF SERVICE SELECTOR.

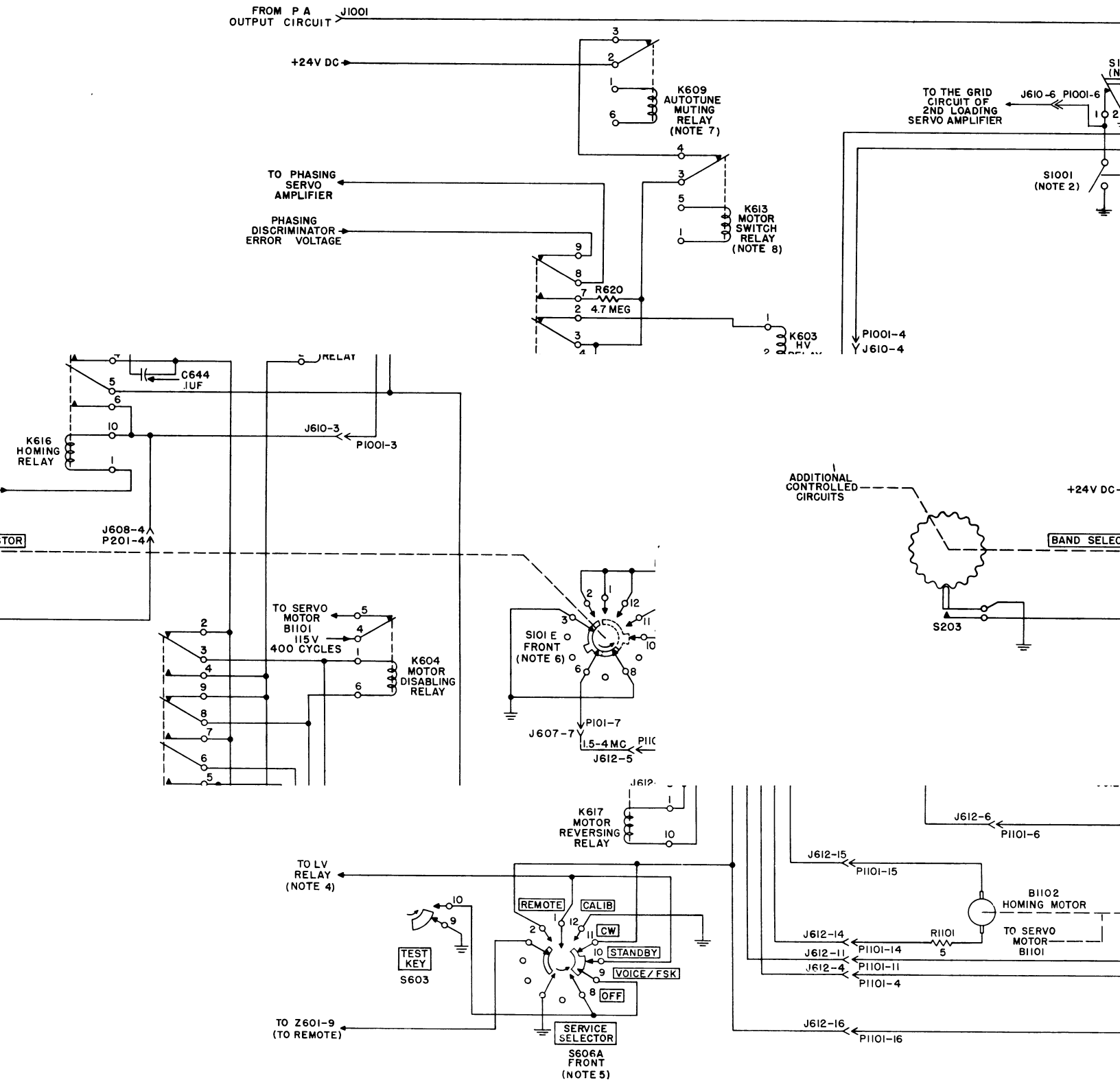

Figure 45. Homing

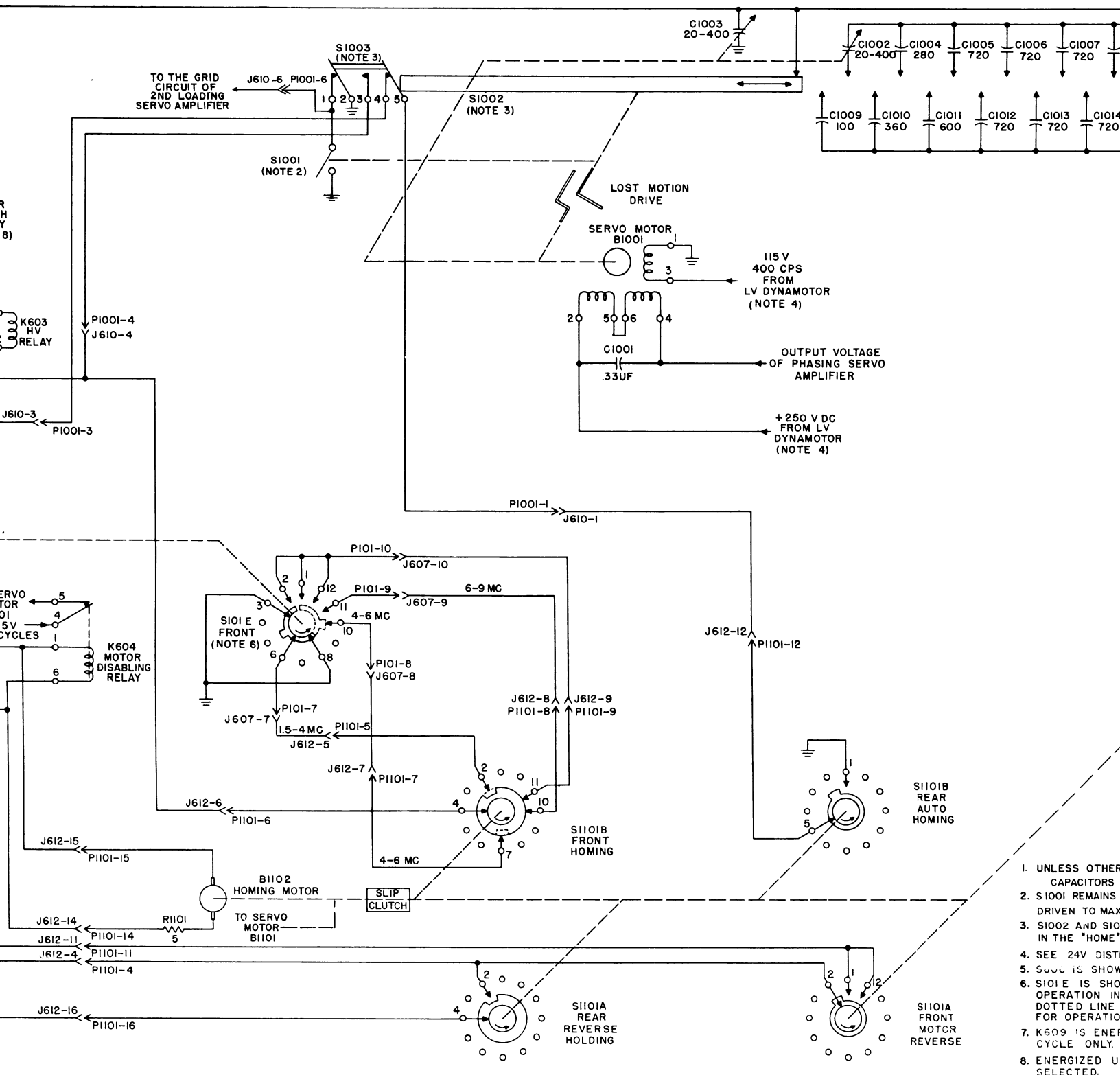
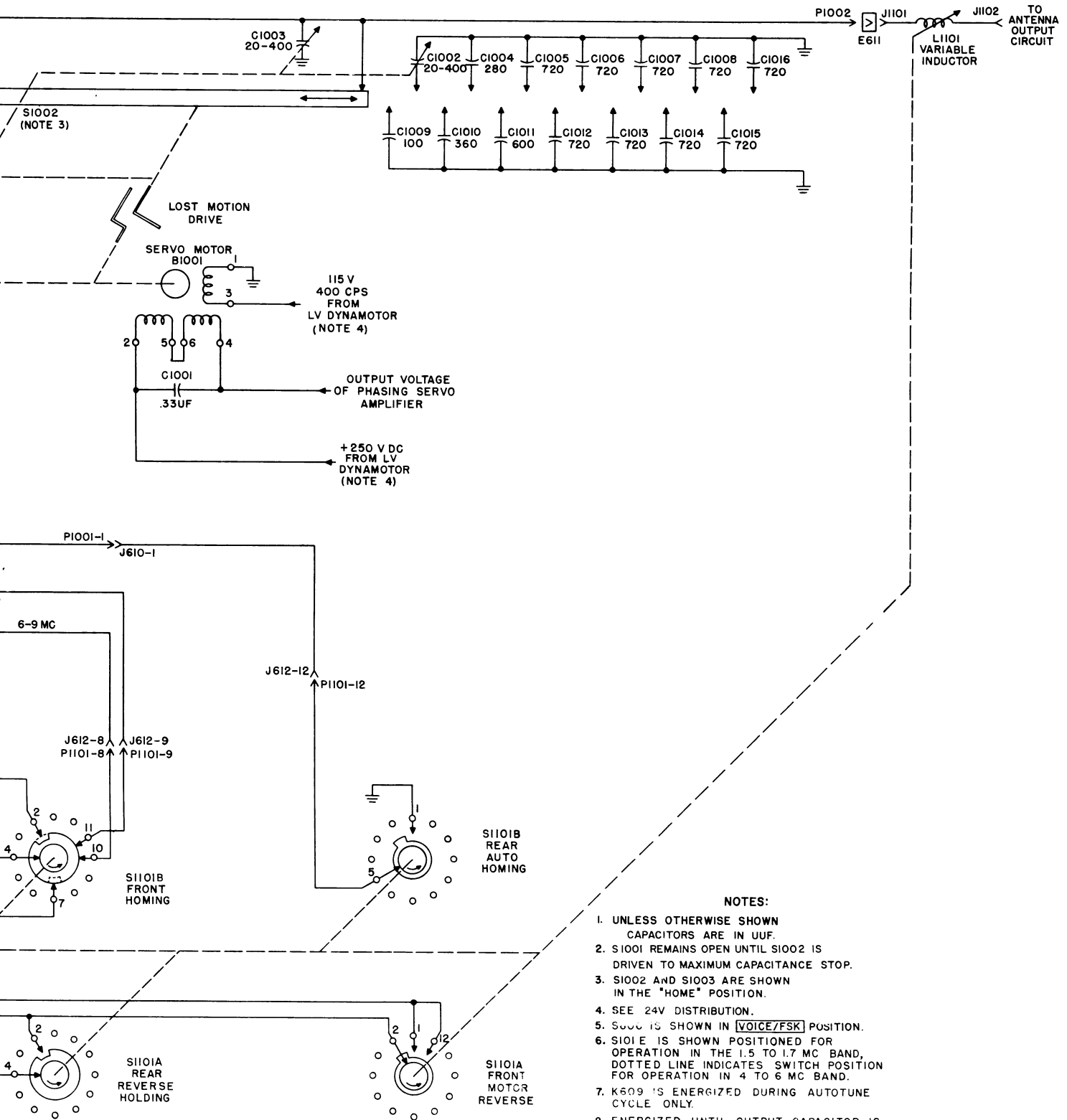

Figure 45. Homing circuits, functional diagram.



NOTES:

1. UNLESS OTHERWISE SHOWN CAPACITORS ARE IN UUF.
2. S1001 REMAINS OPEN UNTIL S1002 IS DRIVEN TO MAXIMUM CAPACITANCE STOP.
3. S1002 AND S1003 ARE SHOWN IN THE "HOME" POSITION.
4. SEE 24V DISTRIBUTION.
5. S1004 IS SHOWN IN [VOICE/FSK] POSITION.
6. S101E IS SHOWN POSITIONED FOR OPERATION IN THE 1.5 TO 1.7 MC BAND, DOTTED LINE INDICATES SWITCH POSITION FOR OPERATION IN 4 TO 6 MC BAND.
7. K609 IS ENERGIZED DURING AUTOTUNE CYCLE ONLY.
8. ENERGIZED UNTIL OUTPUT CAPACITOR IS SELECTED.

TM 806 -13

functional diagram.

390412 O - 56 (In pocket) No. 5

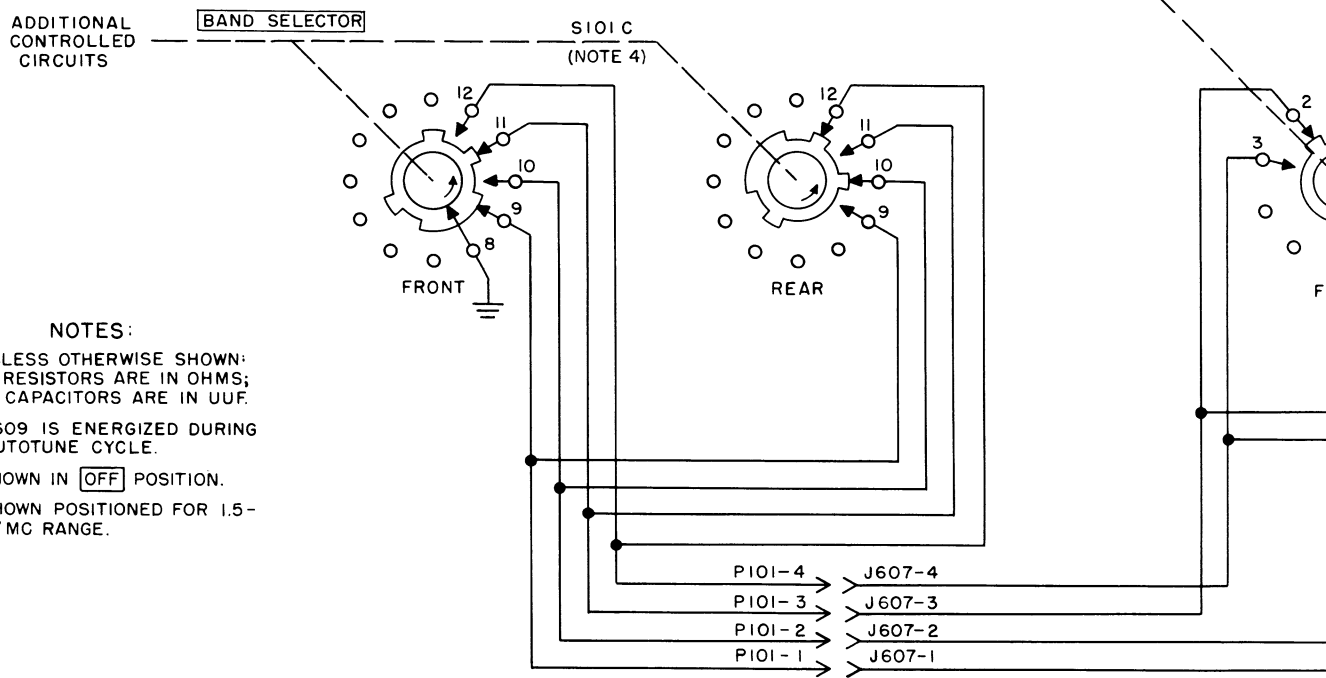
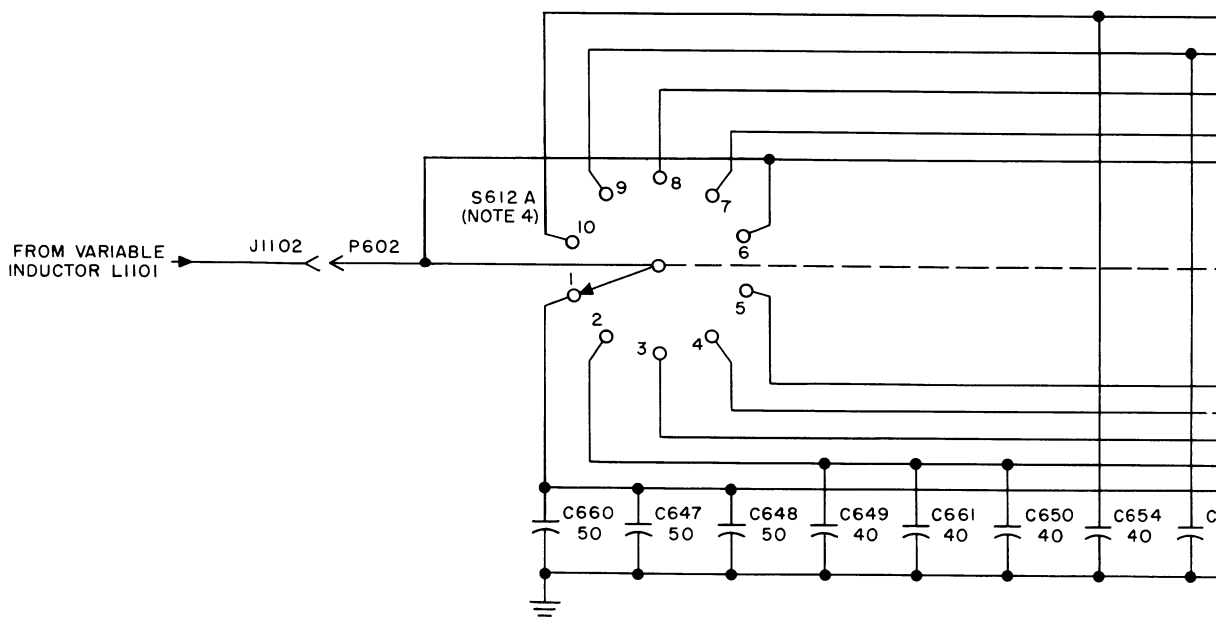

Figure 52

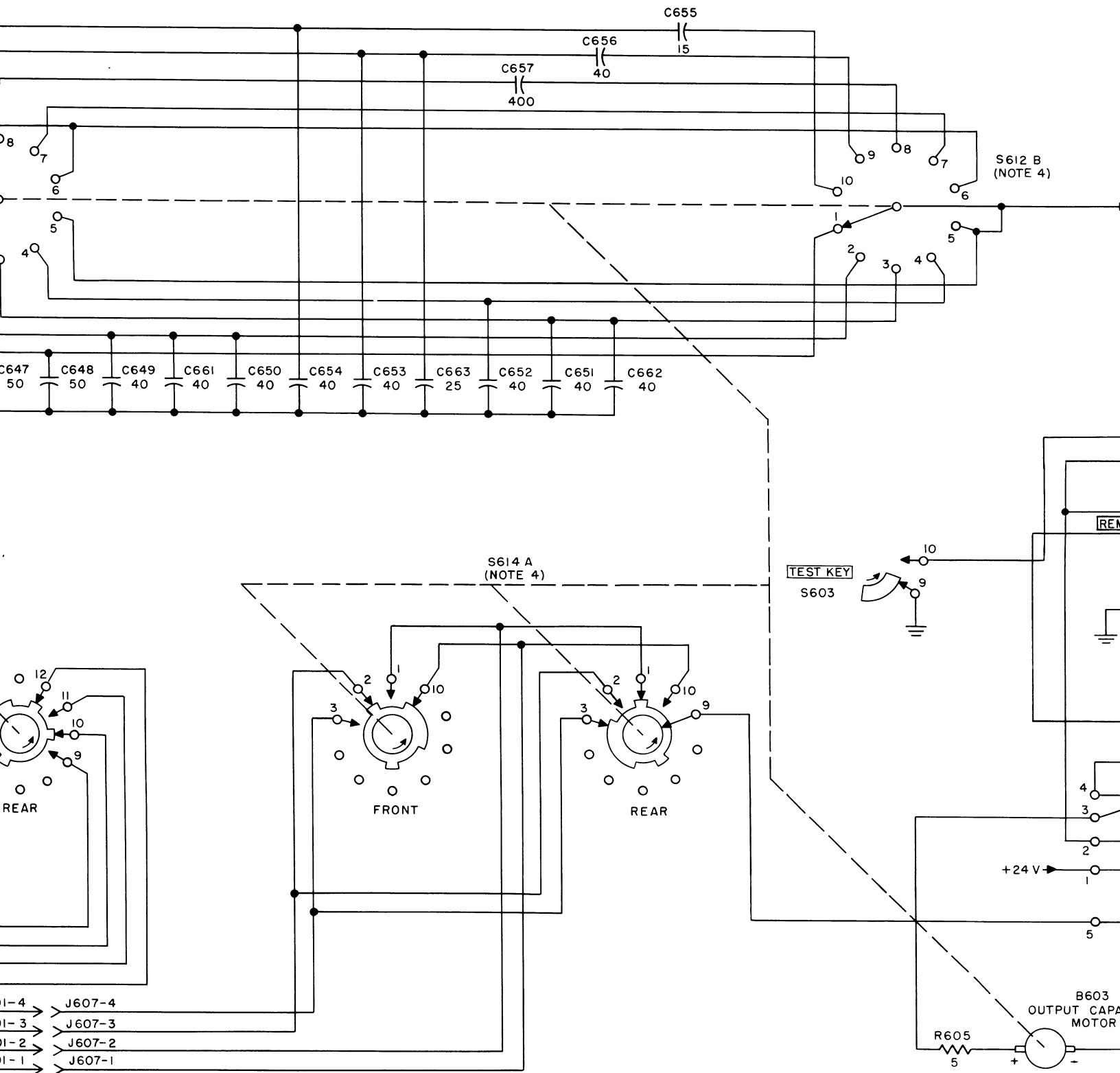
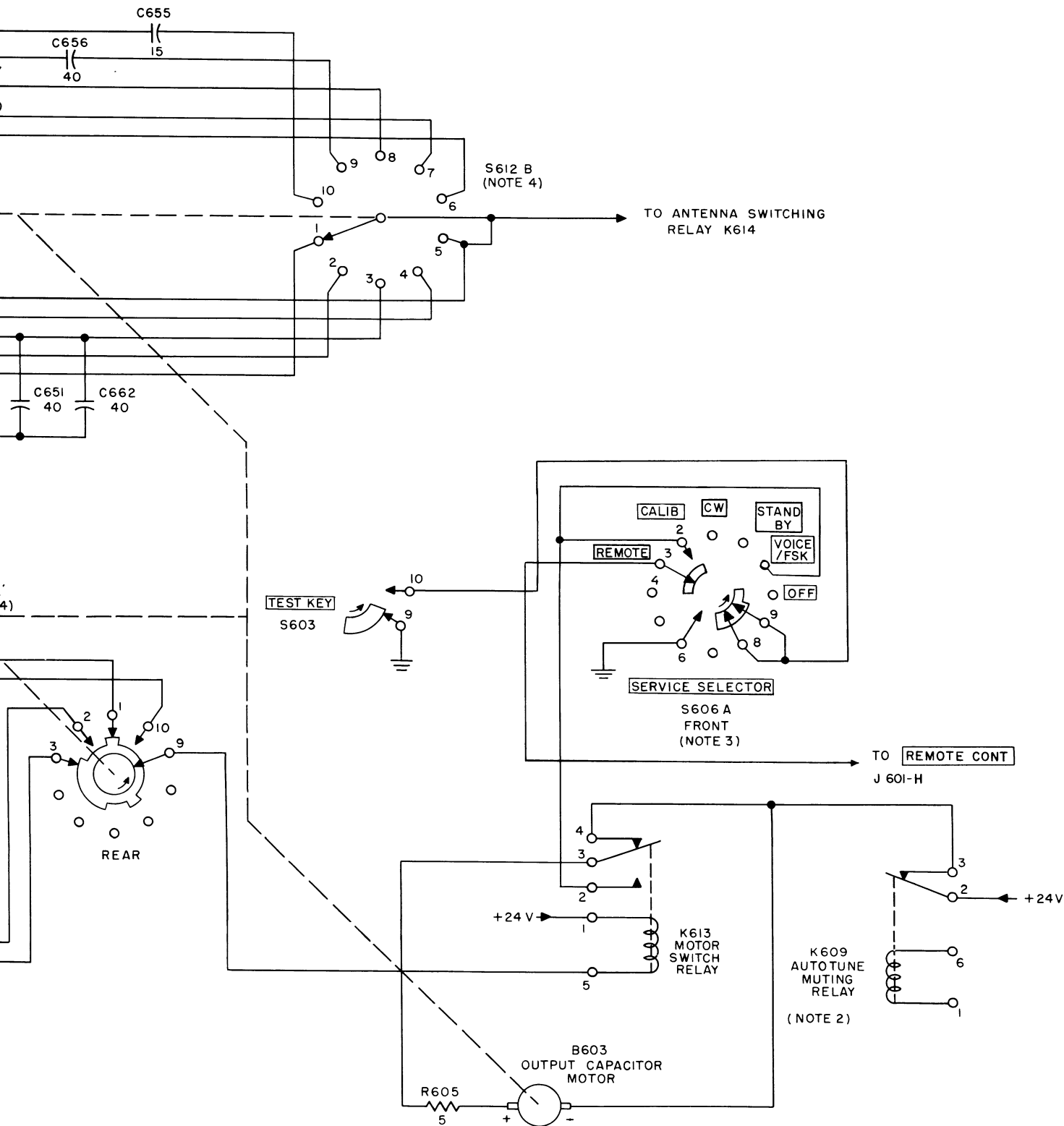

Figure 52. Output capacitor, functional diagram.



functional diagram.

TM 806-49

390412 O - 56 (In pocket) No. 6

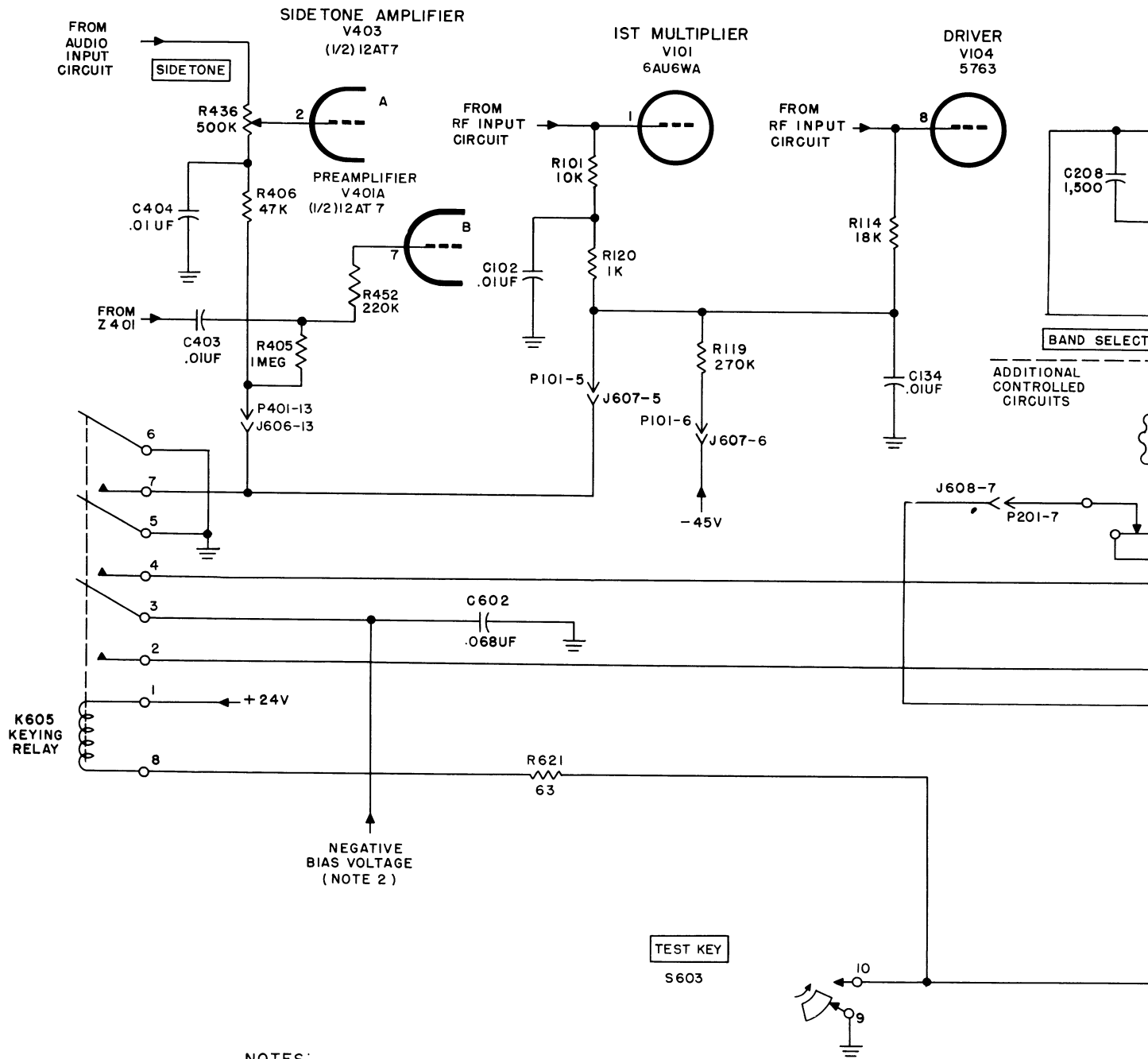

NOTES:

1. UNLESS OTHERWISE SHOWN:
RESISTORS ARE IN OHMS,
CAPACITORS ARE IN UUF.
2. S602 IS SHOWN IN RELAY
POSITION.

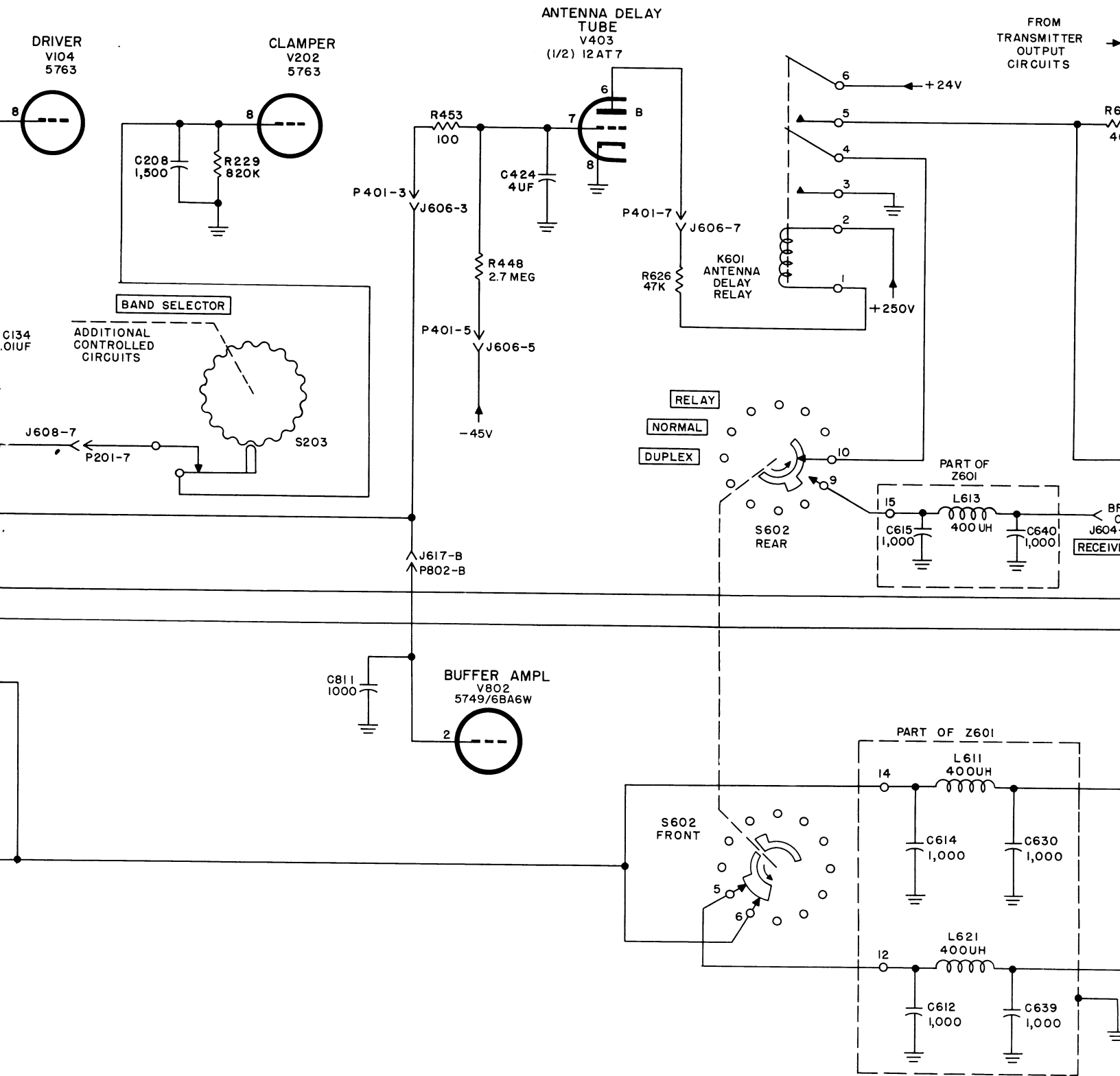
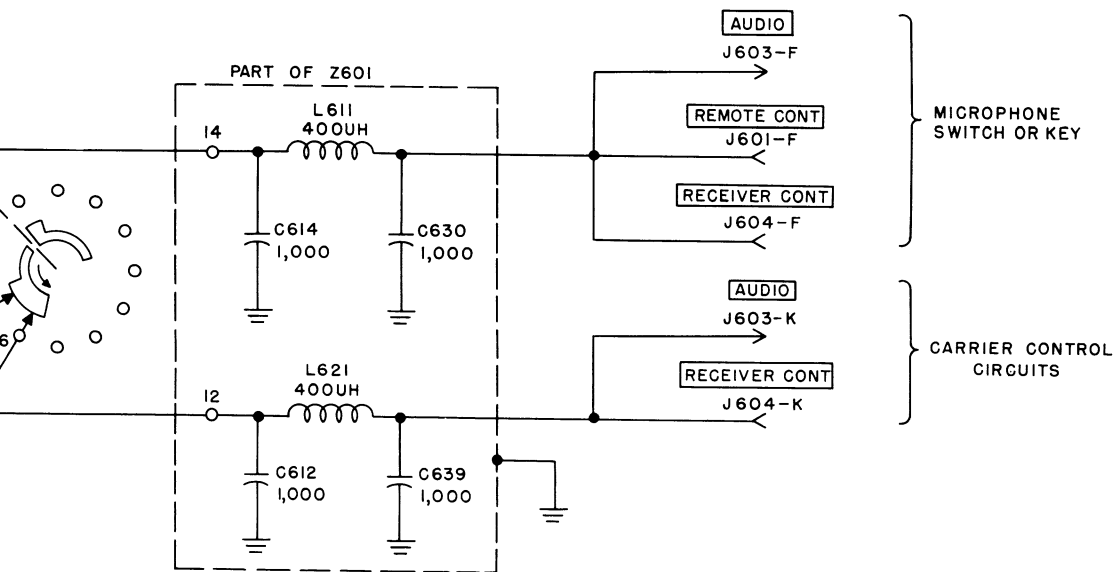
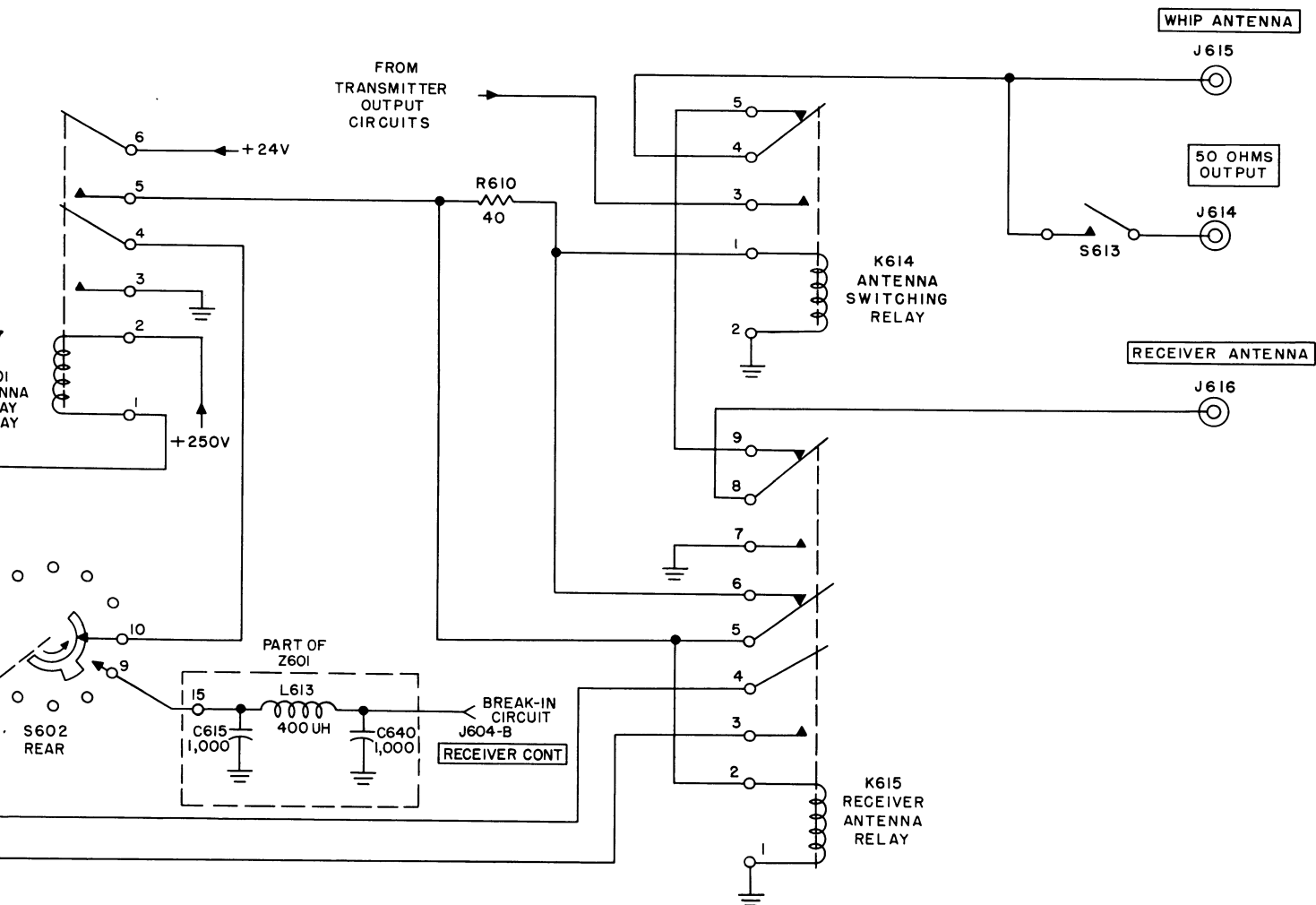

Figure 54. Antenna switch and keying circuits, functional diagram.



TM 806-51

390412 O - 56 (In pocket) No. 7

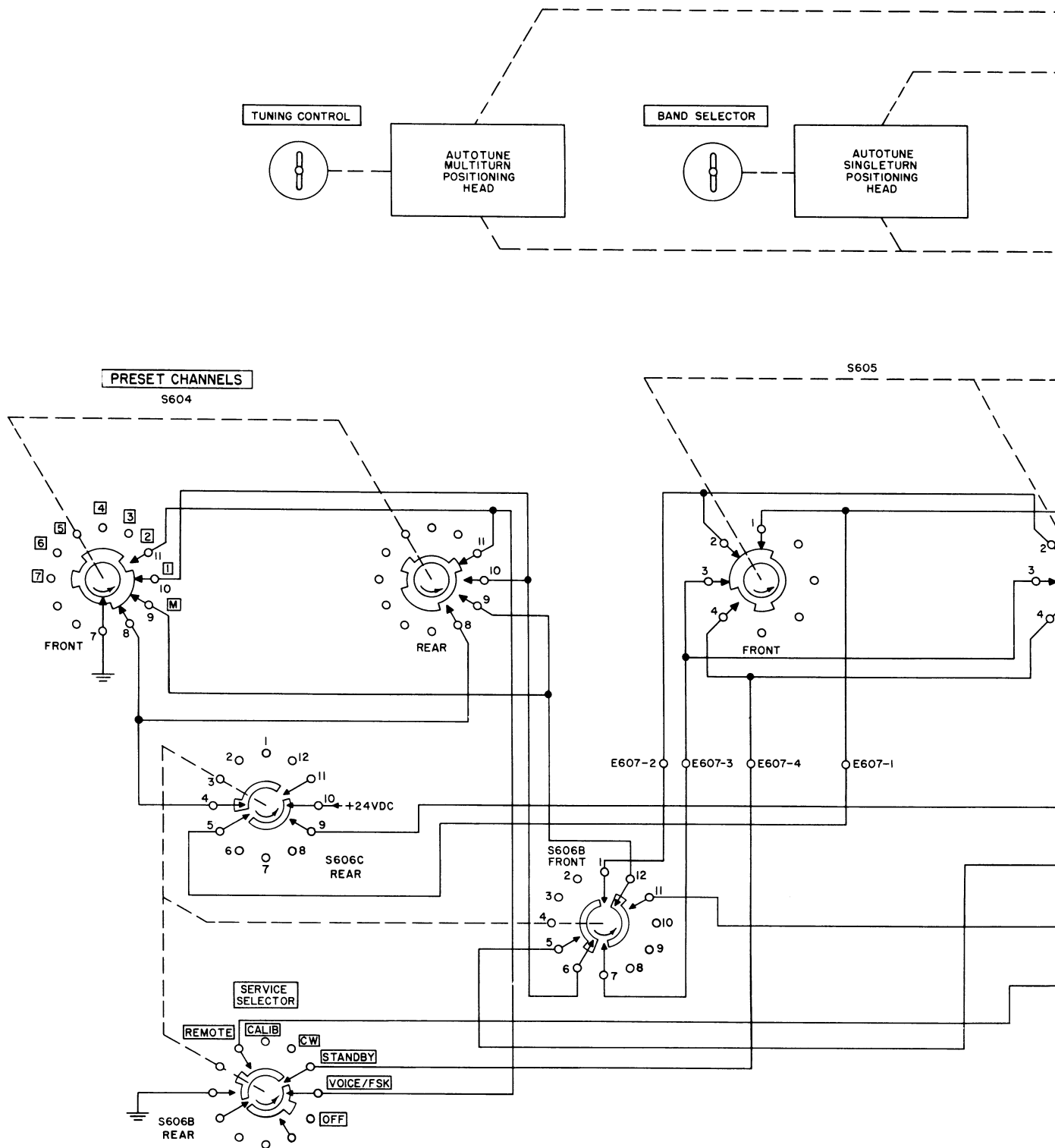
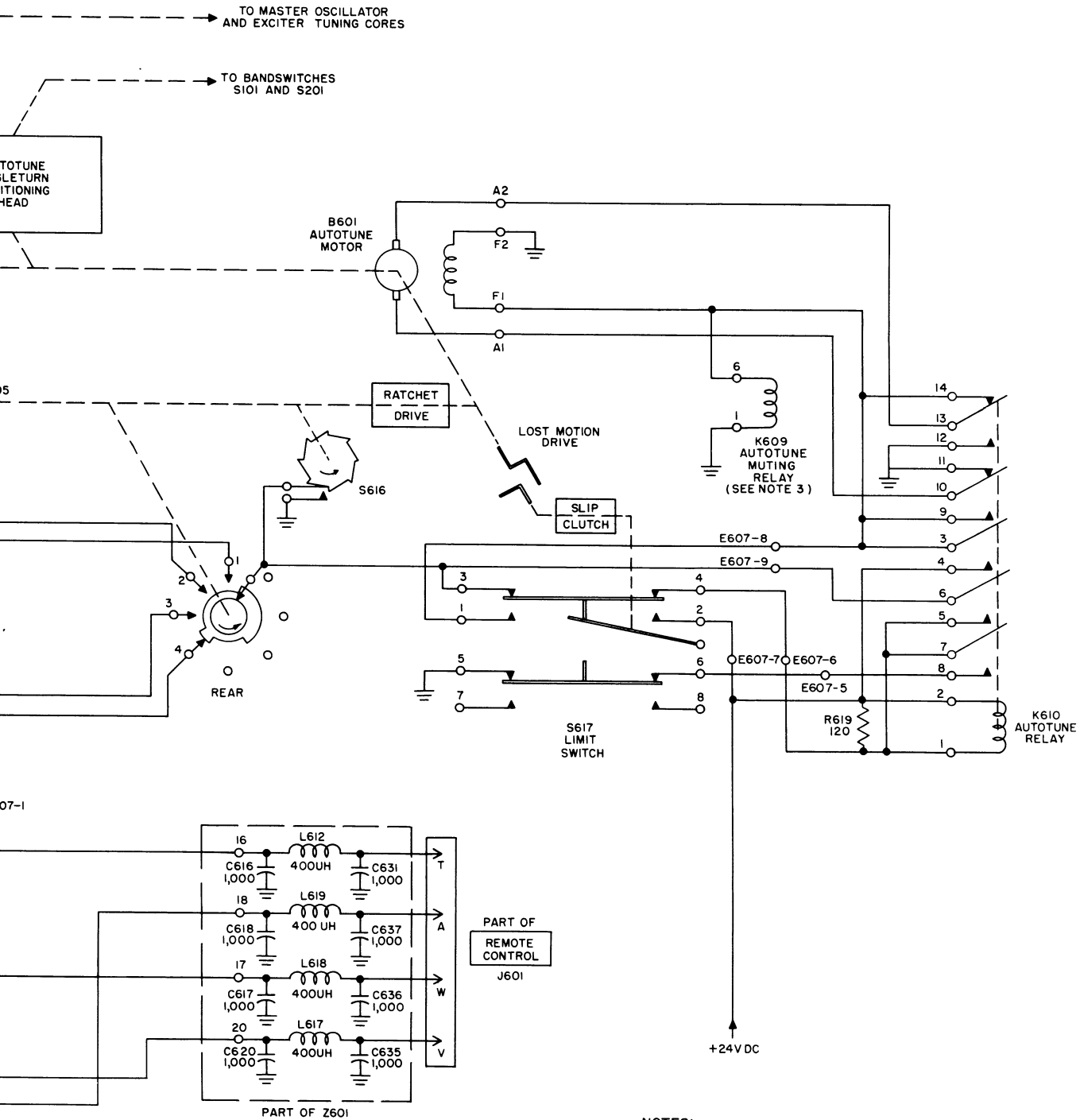

Figure 55. Autotune control circuits, fu



NOTES:

1. S606 IS SHOWN IN **OFF** POSITION.
2. S604 IS SHOWN IN **M** (MANUAL) POSITION.
3. SEE +24-VOLT DISTRIBUTION.
4. UNLESS OTHERWISE SHOWN: CAPACITORS ARE IN UUF.

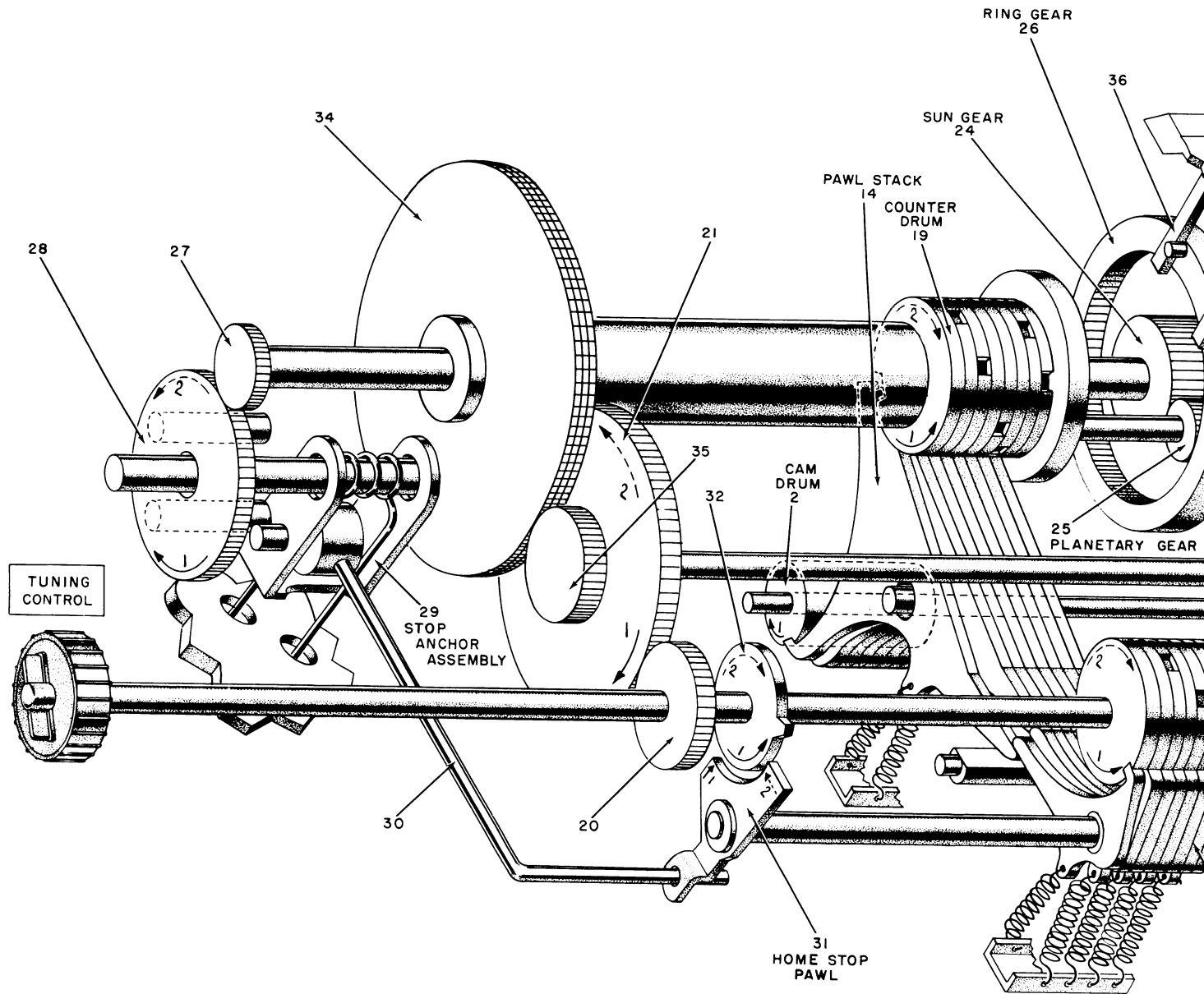
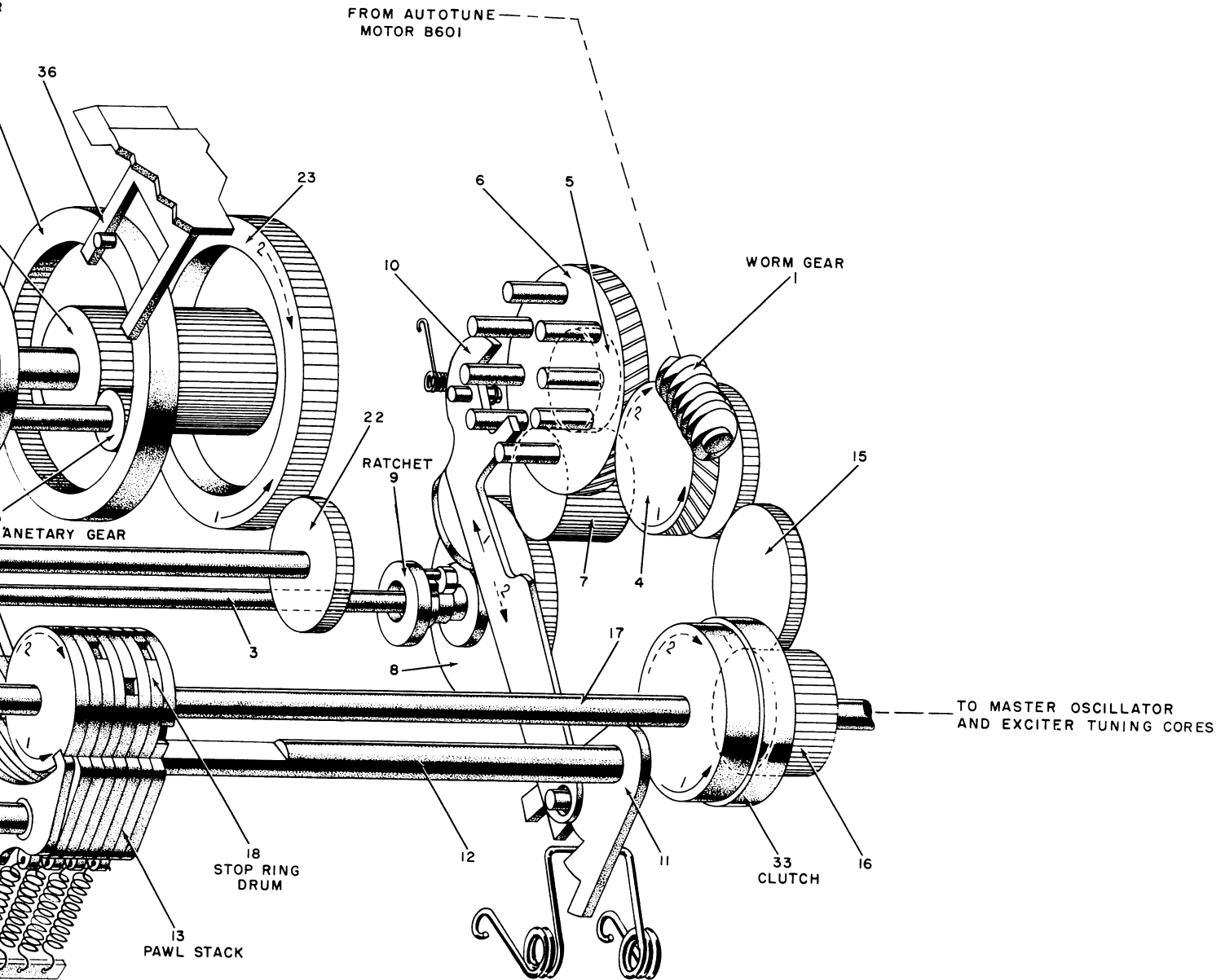

Figure 57. Multiturn positioning head



NOTE:

THIS IS A REPRESENTATIVE DRAWING.
PARTS ARE NOT NECESSARILY DRAWN
TO SCALE.

TM 806-54

390412 O - 56 (In pocket) No. 9

positioning head, representative drawing.

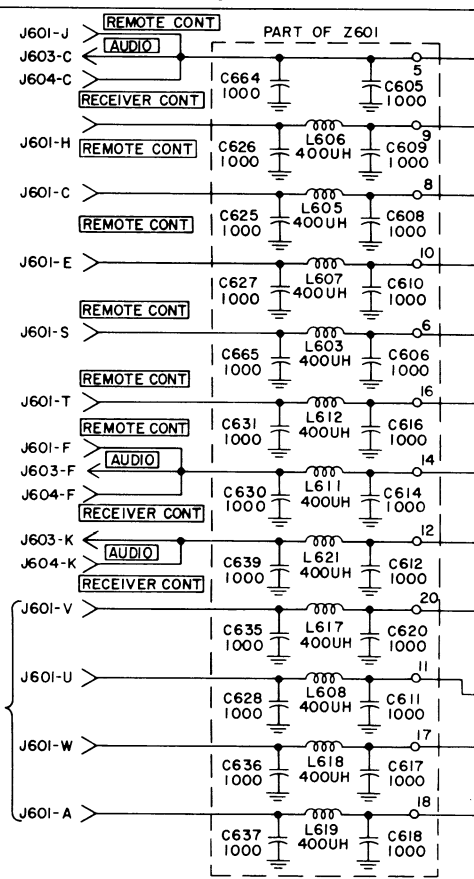
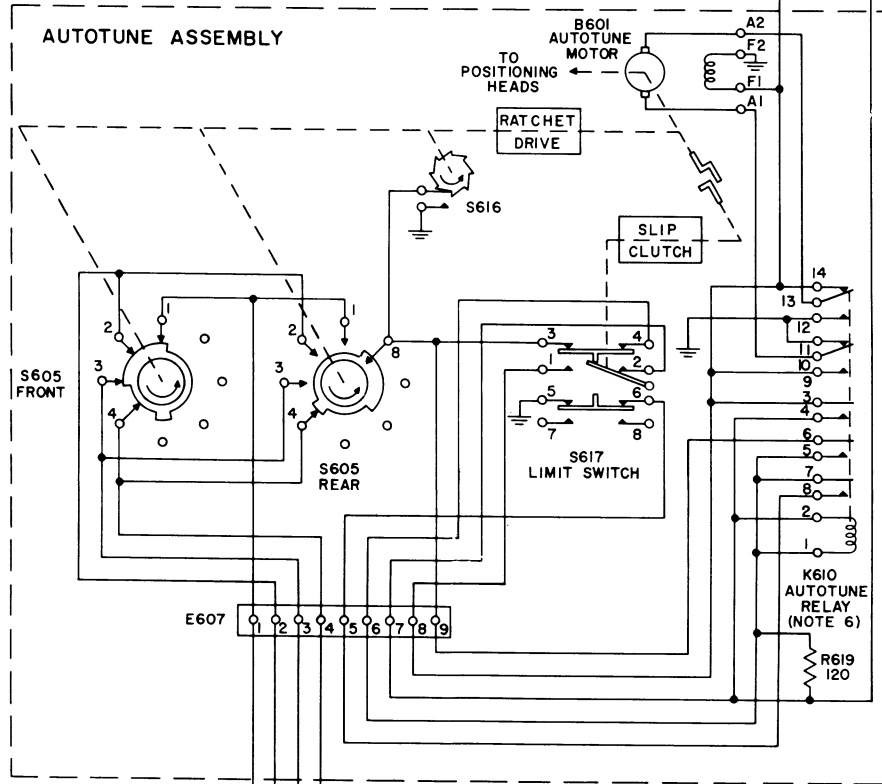
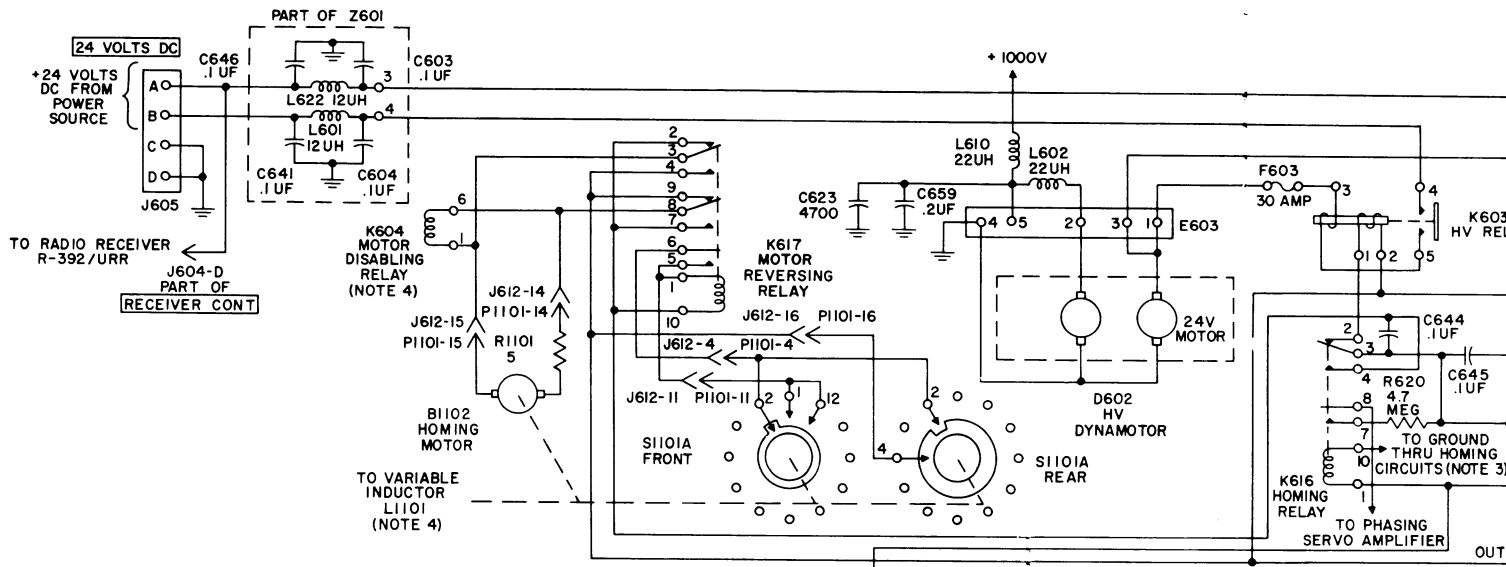

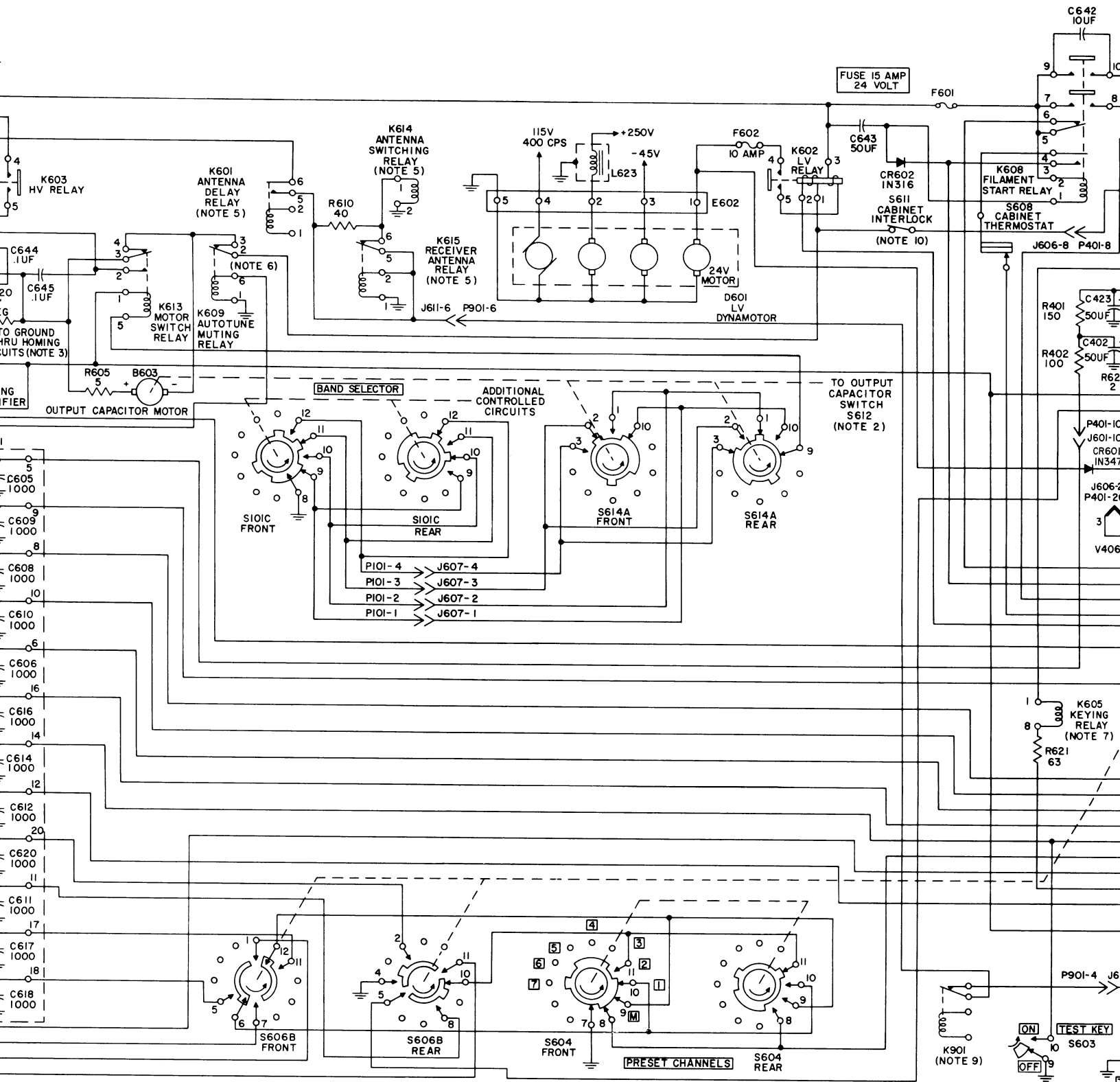
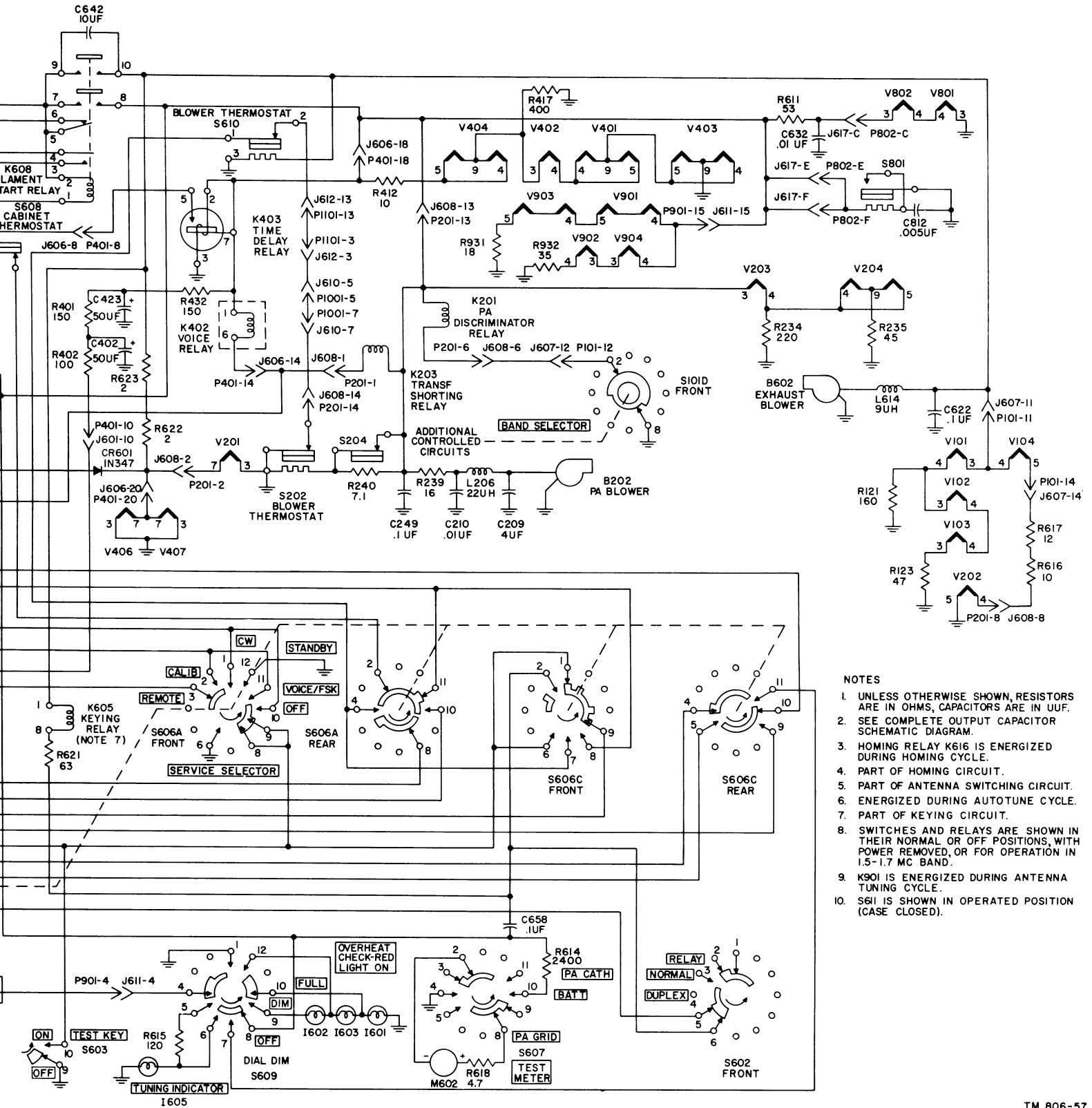
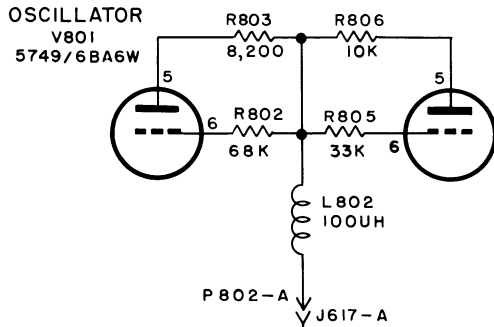

Figure 61. +24-volt distribution, functional diagram.



- NOTES
1. UNLESS OTHERWISE SHOWN, RESISTORS ARE IN OHMS, CAPACITORS ARE IN UUF.
 2. SEE COMPLETE OUTPUT CAPACITOR SCHEMATIC DIAGRAM.
 3. HOMING RELAY K616 IS ENERGIZED DURING HOMING CYCLE.
 4. PART OF HOMING CIRCUIT.
 5. PART OF ANTENNA SWITCHING CIRCUIT.
 6. ENERGIZED DURING AUTOTUNE CYCLE.
 7. PART OF KEYING CIRCUIT.
 8. SWITCHES AND RELAYS ARE SHOWN IN THEIR NORMAL OR OFF POSITIONS, WITH POWER REMOVED, OR FOR OPERATION IN 1.5-1.7 MC BAND.
 9. K901 IS ENERGIZED DURING ANTENNA TUNING CYCLE.
 10. S611 IS SHOWN IN OPERATED POSITION (CASE CLOSED).

BUFFER AMPL
V802
5749/6BA6W



VOLTAGE REGULATOR
V601
0A2

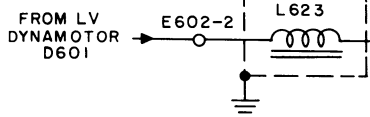
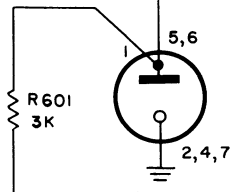

BAND SELECTOR
IST MULTIPLIER
V101
6AU6WA

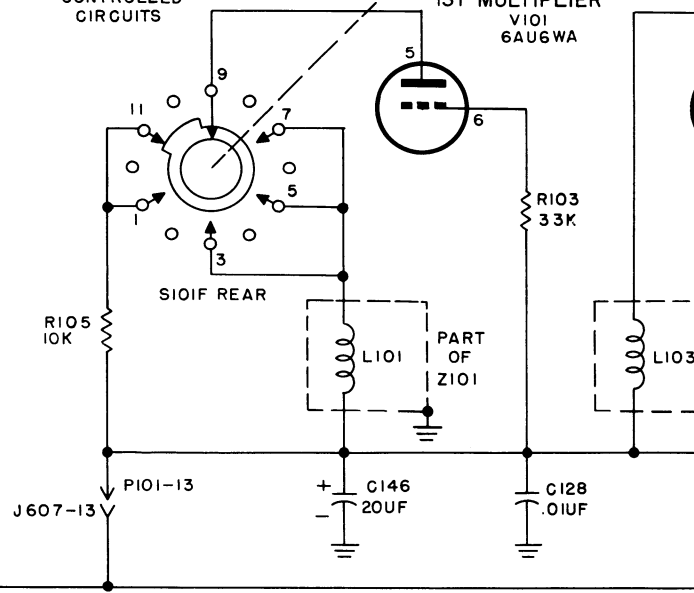

ANTENNA DELAY
TUBE
V403
(1/2) 12AT7

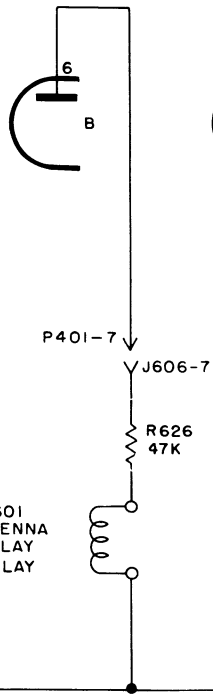

PREAMPLIFIER
V401
(1/2) 12AT7

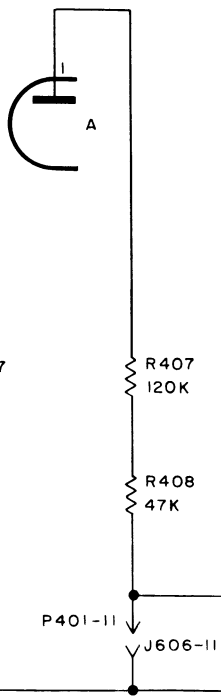

LIMITER
V402
5726/6AL5W

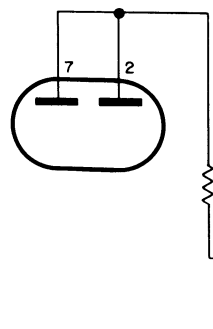

1ST AUDIO AMPL
V401
(1/2) 12AT7

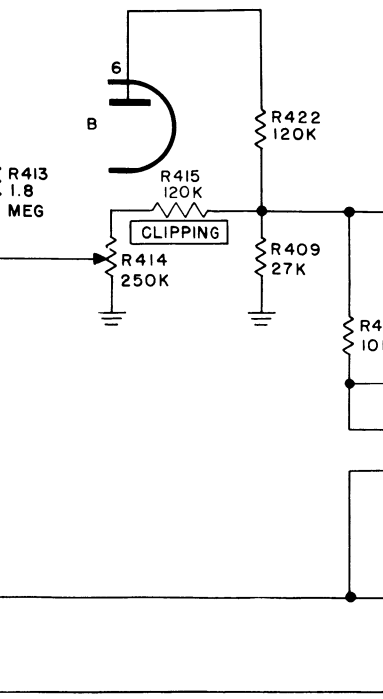

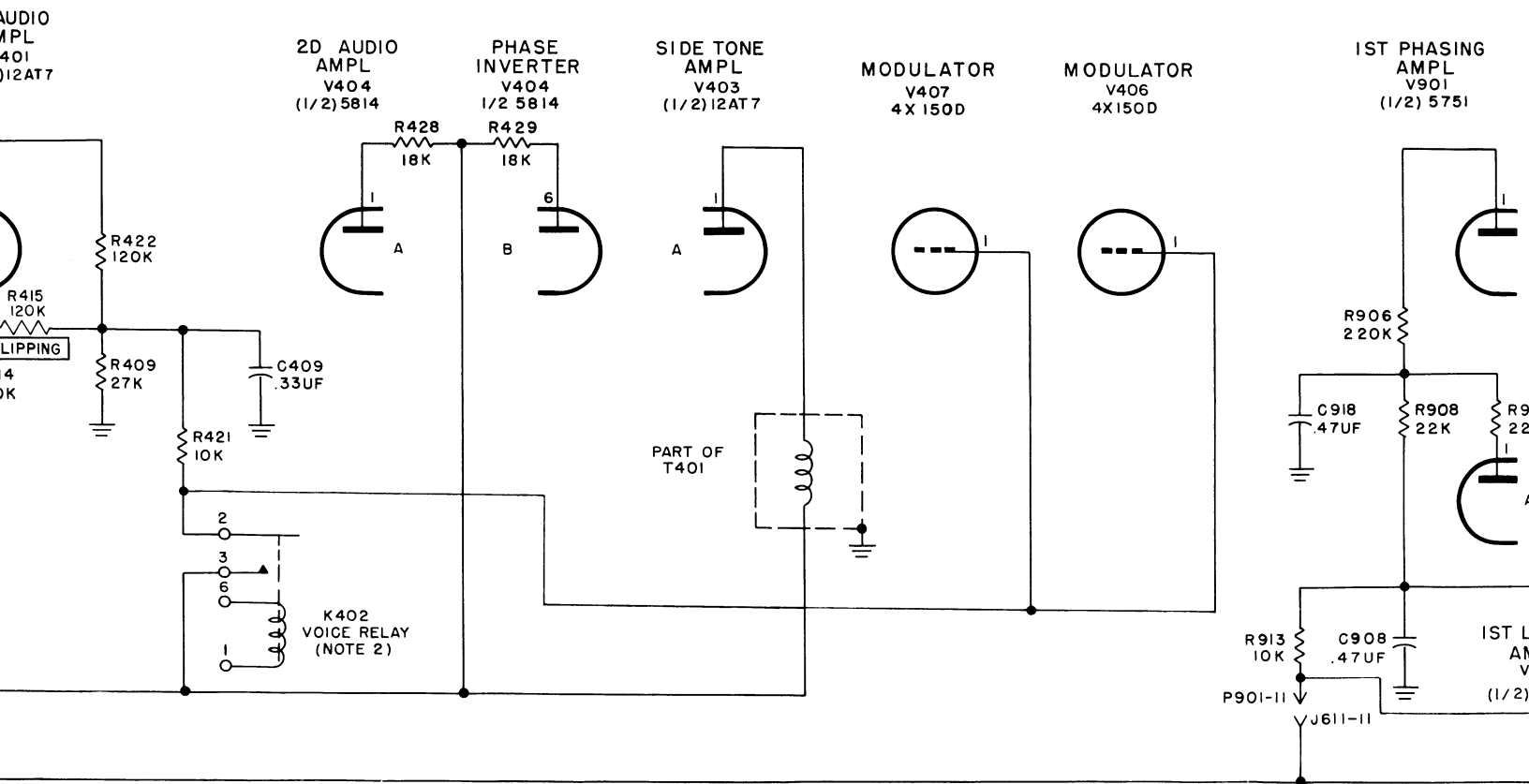
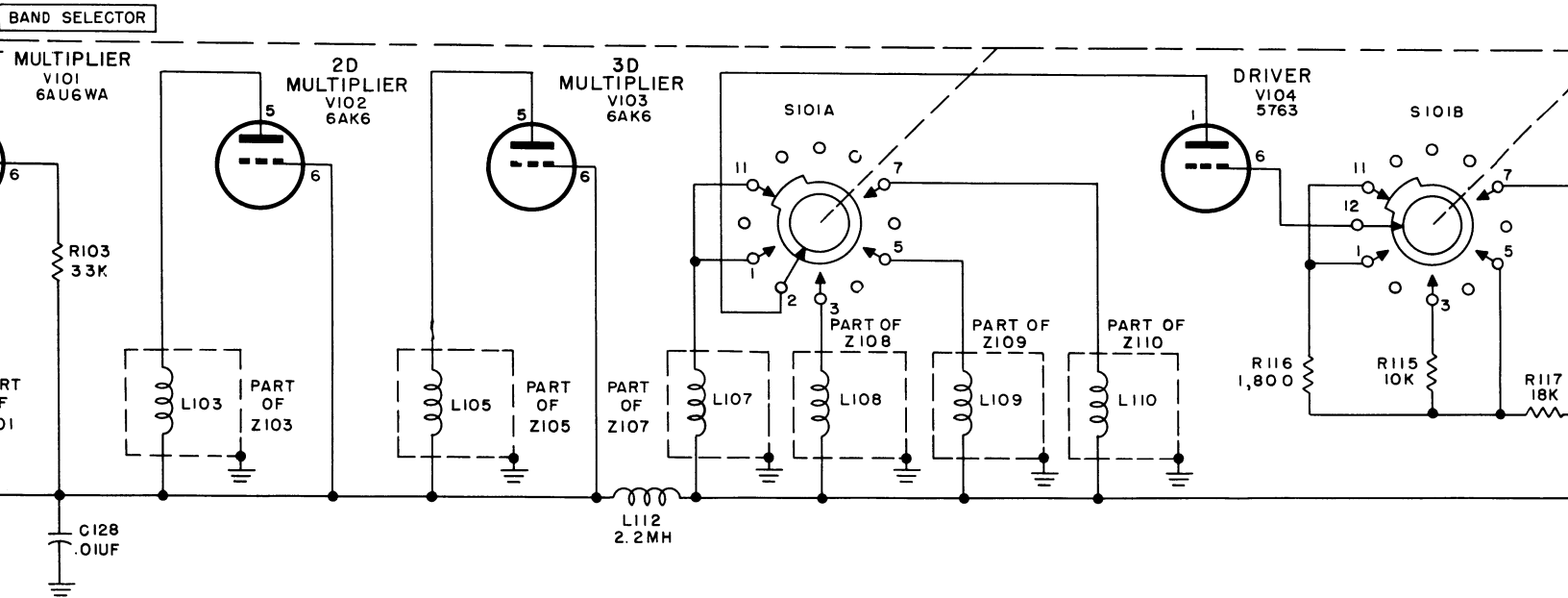
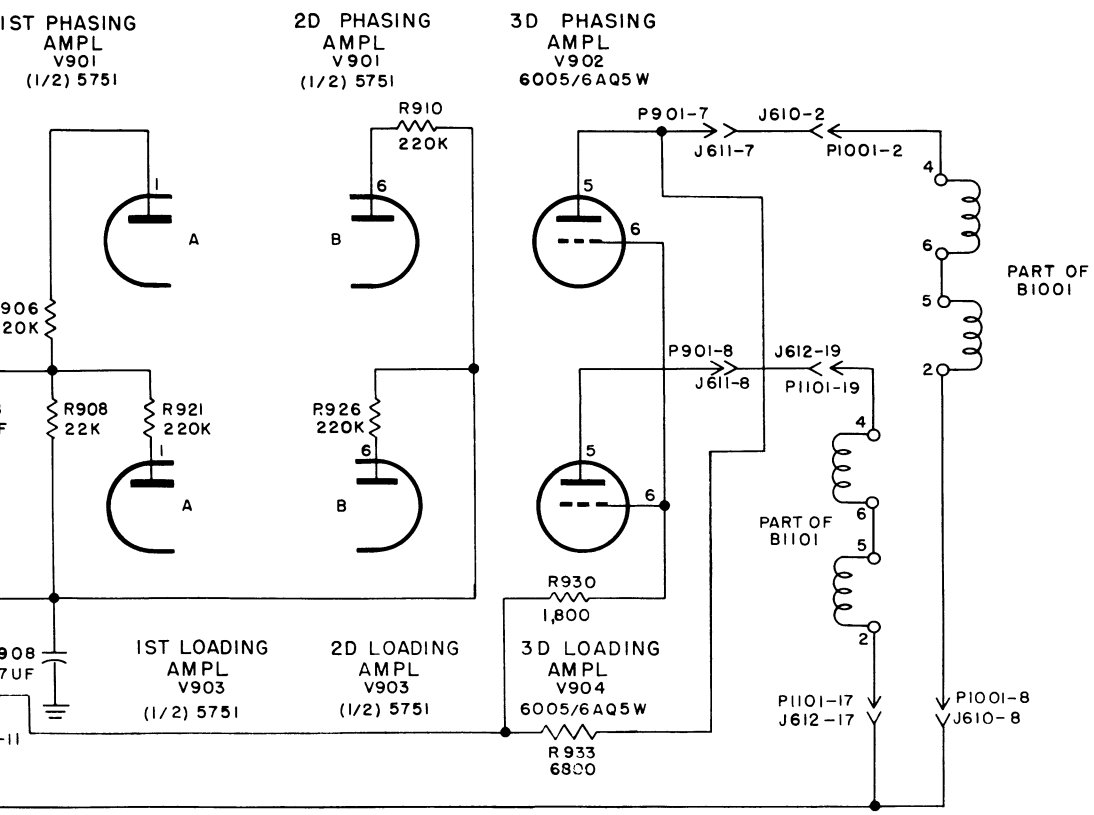
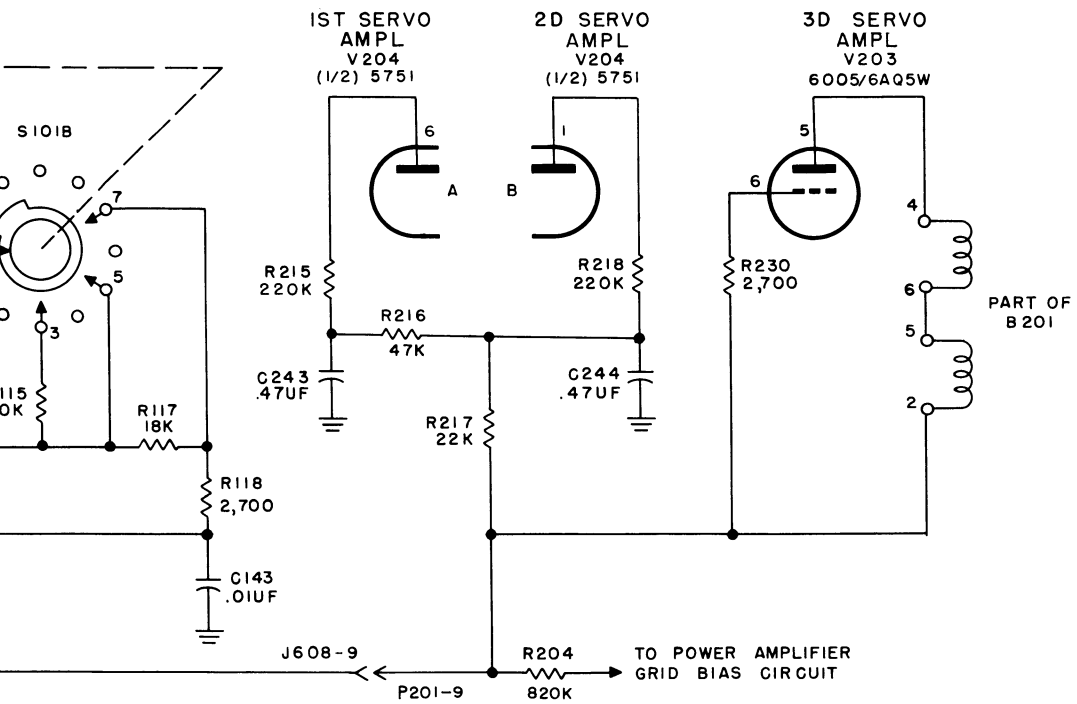

Figure 63. +250-volt distribution, function diagram.



NOTES:

1. UNLESS OTHERWISE SHOWN: RESISTORS ARE IN OHMS, CAPACITORS ARE IN UUF.
2. K402 IS ENERGIZED IN VOICE/FSK OPERATION.

TM806-59

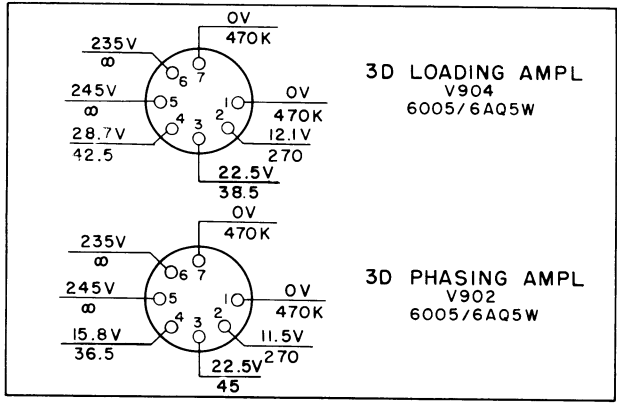

ANTENNA NETWORK
SERVO AMPLIFIER SUBCHASSIS

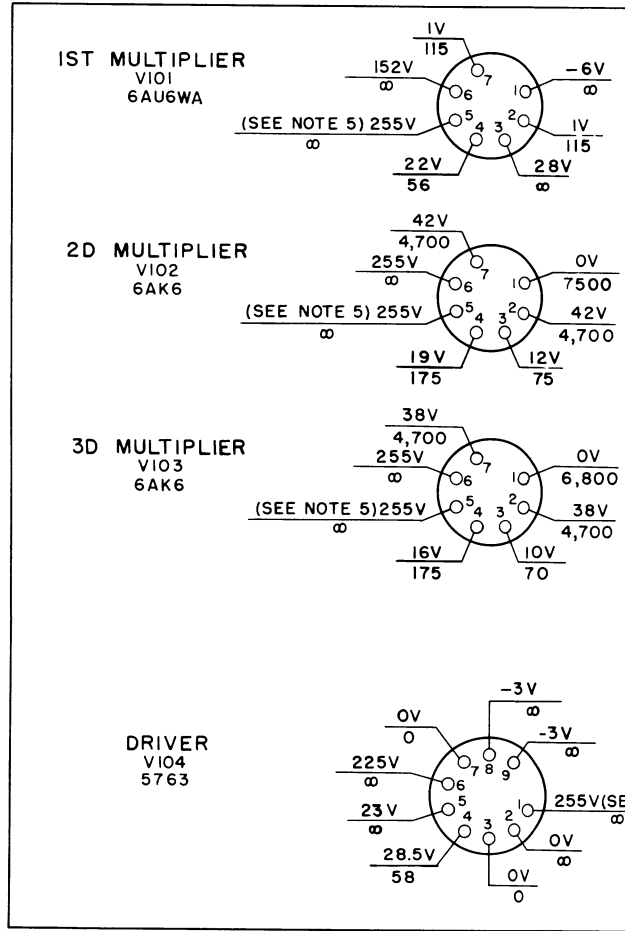

EXCITER SUBCHASSIS

Figure 104. Rad

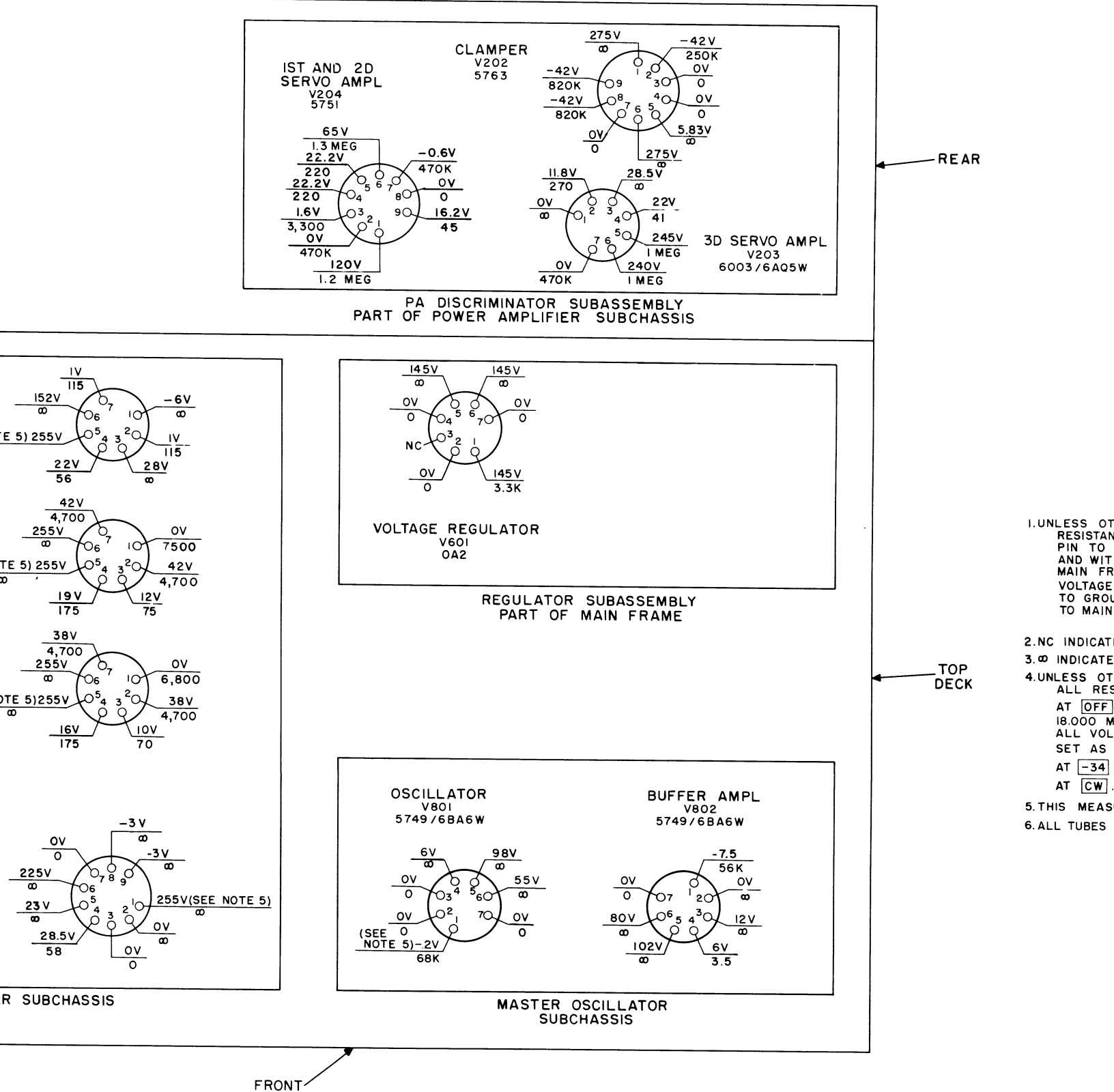

Figure 104. Radio Transmitter T-195/GRC-19, top deck, tube voltage and resistance diagram.

2V
OK
V
0
1V
0
1V

← REAR

3D SERVO AMPL
V203
6003/6A05W

NOTES:

1. UNLESS OTHERWISE SHOWN, RESISTANCES ARE IN OHMS AND ARE MEASURED FROM SOCKET PIN TO GROUND WITH A 20,000-OHMS-PER-VOLT METER AND WITH THE SUBCHASSIS PLUGS DISCONNECTED FROM THE MAIN FRAME.
VOLTAGES ARE DC AND ARE MEASURED FROM SOCKET PIN TO GROUND WITH A VTVM AND WITH SUBCHASSIS CONNECTED TO MAIN FRAME, USING THE REQUIRED BENCH-TEST CABLE.

2. NC INDICATES NO CONNECTION.

3. ∞ INDICATES INFINITY.

4. UNLESS OTHERWISE NOTED, ALL RESISTANCE MEASUREMENTS ARE TAKEN WITH THE SERVICE SELECTOR AT OFF, AND THE BAND SELECTOR AND TUNING CONTROL SET FOR 18.000 MC AS SHOWN ON THE FREQUENCY INDICATOR. ALL VOLTAGE MEASUREMENTS ARE TAKEN AT 18 MC WITH THE CONTROL SET AS FOLLOWS: DIAL DIM AT FULL, TEST KEY AT ON, LINE LEVEL AT -34, RELAY-NORMAL-DUPLEX AT NORMAL, AND SERVICE SELECTOR AT CW.

5. THIS MEASUREMENT TAKEN WITH TEST KEY AT OFF.

6. ALL TUBES IN EACH SUBCHASSIS REMOVED.

← TOP DECK

R AMPL
02
5BA6W

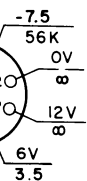

diagram.

TM 806-116

390412 O - 56 (In pocket) No. 13

ANTENNA-NETWORK S
AMPLIFIER SUBCHAS

1ST AND 2D
LOADING AMPL
V903
5751

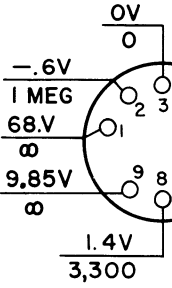

1ST AND 2D
PHASING AMPL
V901
5751

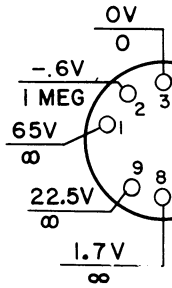

POWER
AMPLIFIER
SUBCHASSIS

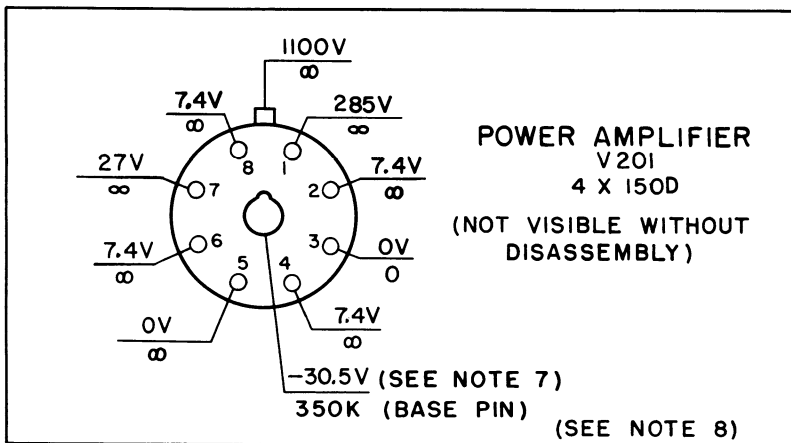

REAR

ANTENNA-NETWORK SERVO AMPLIFIER SUBCHASSIS

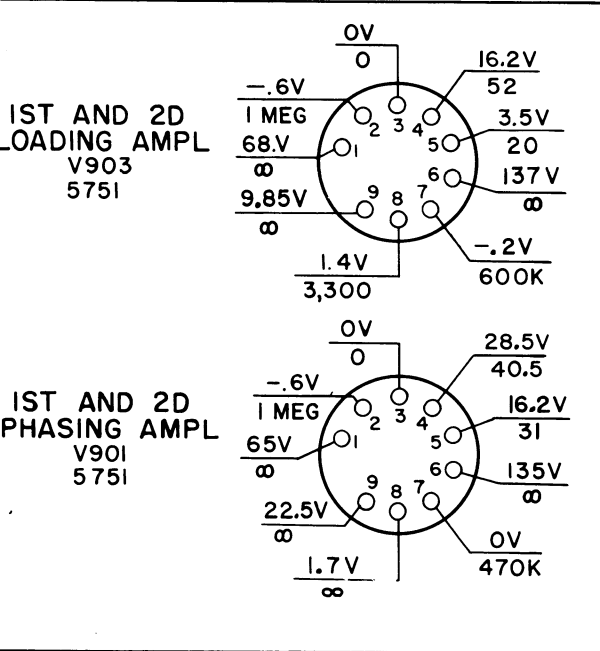

MODULATOR SUBCHASSIS (SEE NOTE 6)

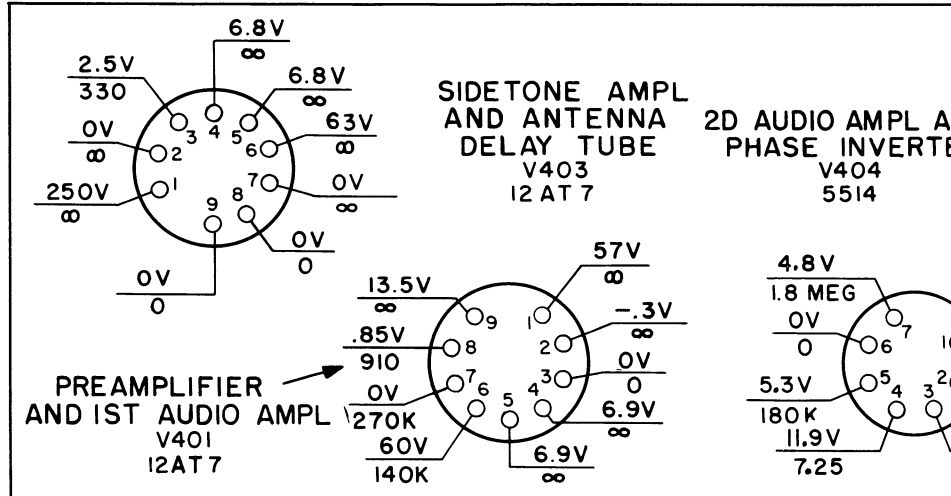

MODULATOR V407 4 X 150D

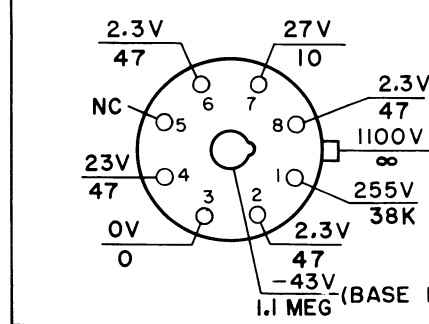

FRONT

Figure 105. Radio Transmitter T-195/GRC-19, bottom deck, tube voltage and resistances.

MODULATOR SUBCHASSIS
(SEE NOTE 6)

MODULATOR AMPL AND ANTENNA RELAY TUBE
V403
12 AT 7

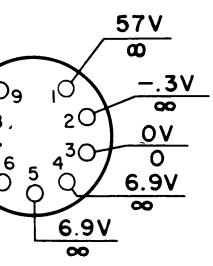

2D AUDIO AMPL AND PHASE INVERTER
V404
5514

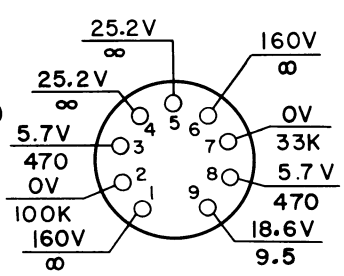
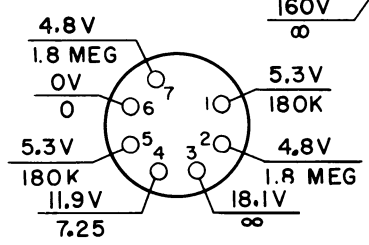

LIMITER
V402
5726 / 6AL5W

MODULATOR
V407
4 X 150D

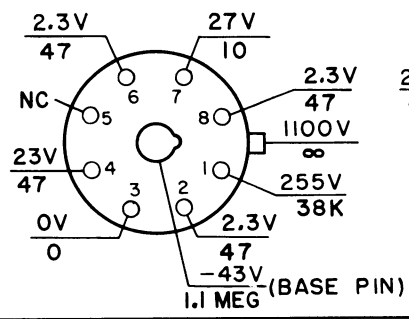

(BASE PIN) -43V
1.1 MEG

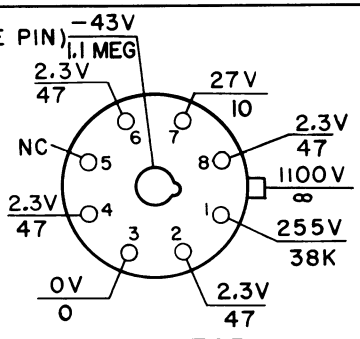

MODULATOR
V406
4 X 150D
(SEE NOTE 7)

1. UNLESS OTHERWISE SHOWN, RESISTANCES ARE IN OHMS A PIN TO GROUND WITH A 20 AND WITH THE SUBCHASSIS TO THE MAIN FRAME. VOLTAGES ARE DC AND A PIN TO GROUND WITH A VT CONNECTED TO MAIN FRAME, BENCH-TEST CABLE.
2. NC INDICATES NO CONNECTION
3. ∞ INDICATES INFINITY.
4. UNLESS OTHERWISE NOTED, ALL RESISTANCE MEASUREMENTS AT [OFF], AND THE [BAND] 18.000 MC AS SHOWN ON THE ALL VOLTAGE MEASUREMENTS AS FOLLOWS: [DIAL DIM] AT [-34], [RELAY-NORMAL] AT [CW].
5. THIS MEASUREMENT TAKEN WITH
6. VOLTAGE MEASUREMENT FOR [SERVICE SELECTOR] AT [VOICE]
7. THE MEASUREMENTS FOR THE TERMINALS 2 AND 1 RESPECTIVELY
8. MEASUREMENTS FOR SOCKET TERMINALS E205, E207, E206 SOCKET XV201
9. ALL TUBES IN EACH SUBCHASSIS

GRC-19, bottom deck, tube voltage and resistance diagram.

NOTES:

1. UNLESS OTHERWISE SHOWN, RESISTANCES ARE IN OHMS AND ARE MEASURED FROM SOCKET PIN TO GROUND WITH A 20,000-OHMS-PER-VOLT METER, AND WITH THE SUBCHASSIS PLUGS DISCONNECTED FROM THE MAIN FRAME. VOLTAGES ARE DC AND ARE MEASURED FROM SOCKET PIN TO GROUND WITH A VTVM AND WITH THE SUBCHASSIS CONNECTED TO MAIN FRAME, USING THE REQUIRED BENCH-TEST CABLE.
2. NC INDICATES NO CONNECTION.
3. ∞ INDICATES INFINITY.
4. UNLESS OTHERWISE NOTED, ALL RESISTANCE MEASUREMENTS ARE TAKEN WITH THE **SERVICE SELECTOR** AT **OFF**, AND THE **BAND SELECTOR** AND **TUNING CONTROL** SET FOR 18.000 MC AS SHOWN ON THE FREQUENCY INDICATOR. ALL VOLTAGE MEASUREMENTS ARE TAKEN AT 18 MC WITH THE CONTROLS SET AS FOLLOWS: **DIAL DIM** AT **FULL**, **TEST KEY** AT **ON**, **LINE LEVEL** AT **-34**, **RELAY-NORMAL-DUPLEX** AT **NORMAL**, AND **SERVICE SELECTOR** AT **CW**.
5. THIS MEASUREMENT TAKEN WITH **TEST KEY** AT **OFF**.
6. VOLTAGE MEASUREMENT FOR THE MODULATOR SUBCHASSIS ARE MADE WITH **SERVICE SELECTOR** AT **VOICE** AND NO MODULATION INPUT TO THE TRANSMITTER.
7. THE MEASUREMENTS FOR THE PLATES OF V406 AND V407 ARE TAKEN AT TERMINALS 2 AND 1 RESPECTIVELY OF T402.
8. MEASUREMENTS FOR SOCKET PINS 2,5,7 AND BASE PIN OF V201 ARE TAKEN AT TERMINALS E205, E207, E206, AND E208 RESPECTIVELY LOCATED ON SHIELD NEAR SOCKET XV201.
9. ALL TUBES IN EACH SUBCHASSIS REMOVED.

TM 806-II7

390412 O - 56 (In pocket) No. 14

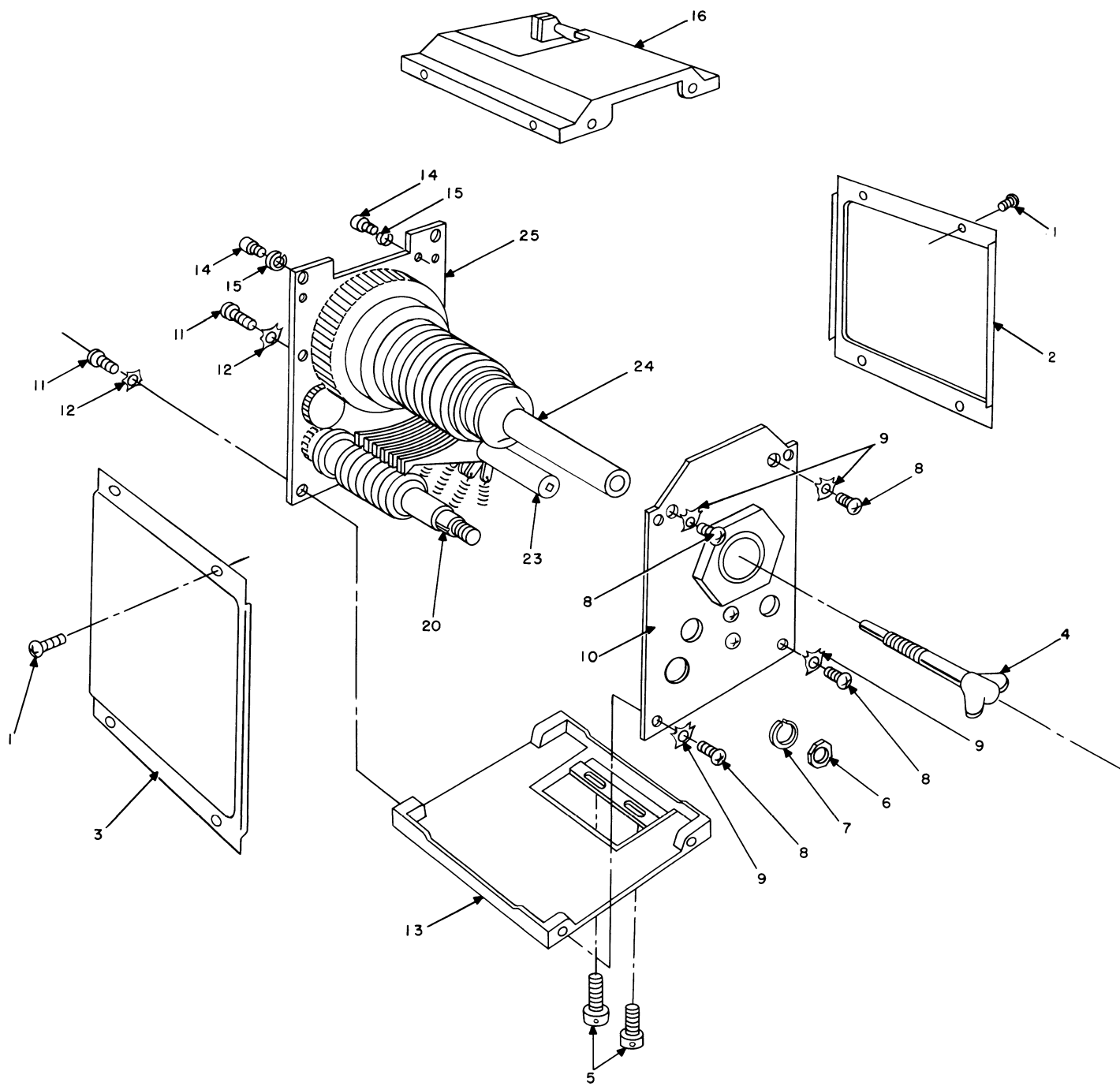

Figure 113. Disassembly

16

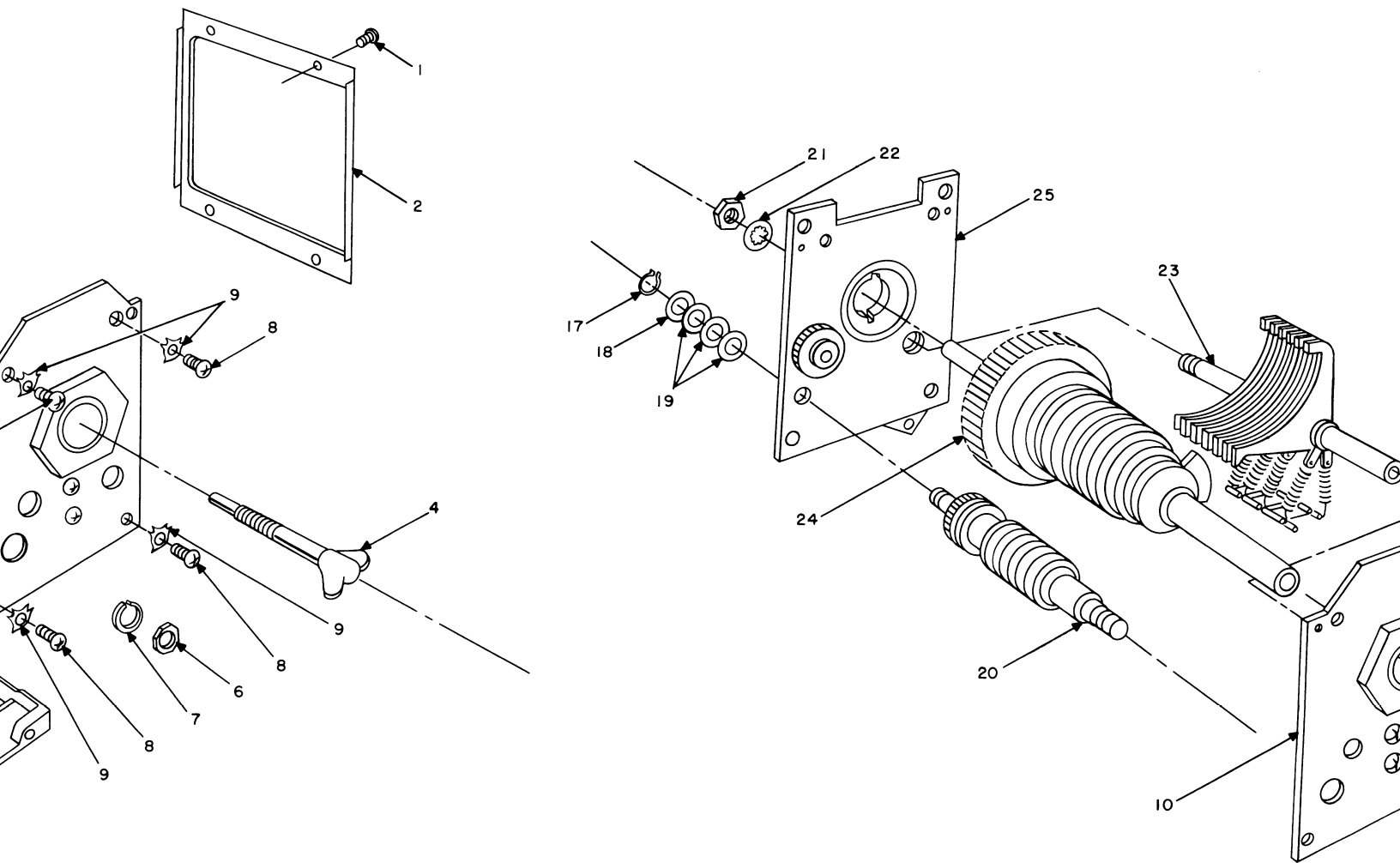
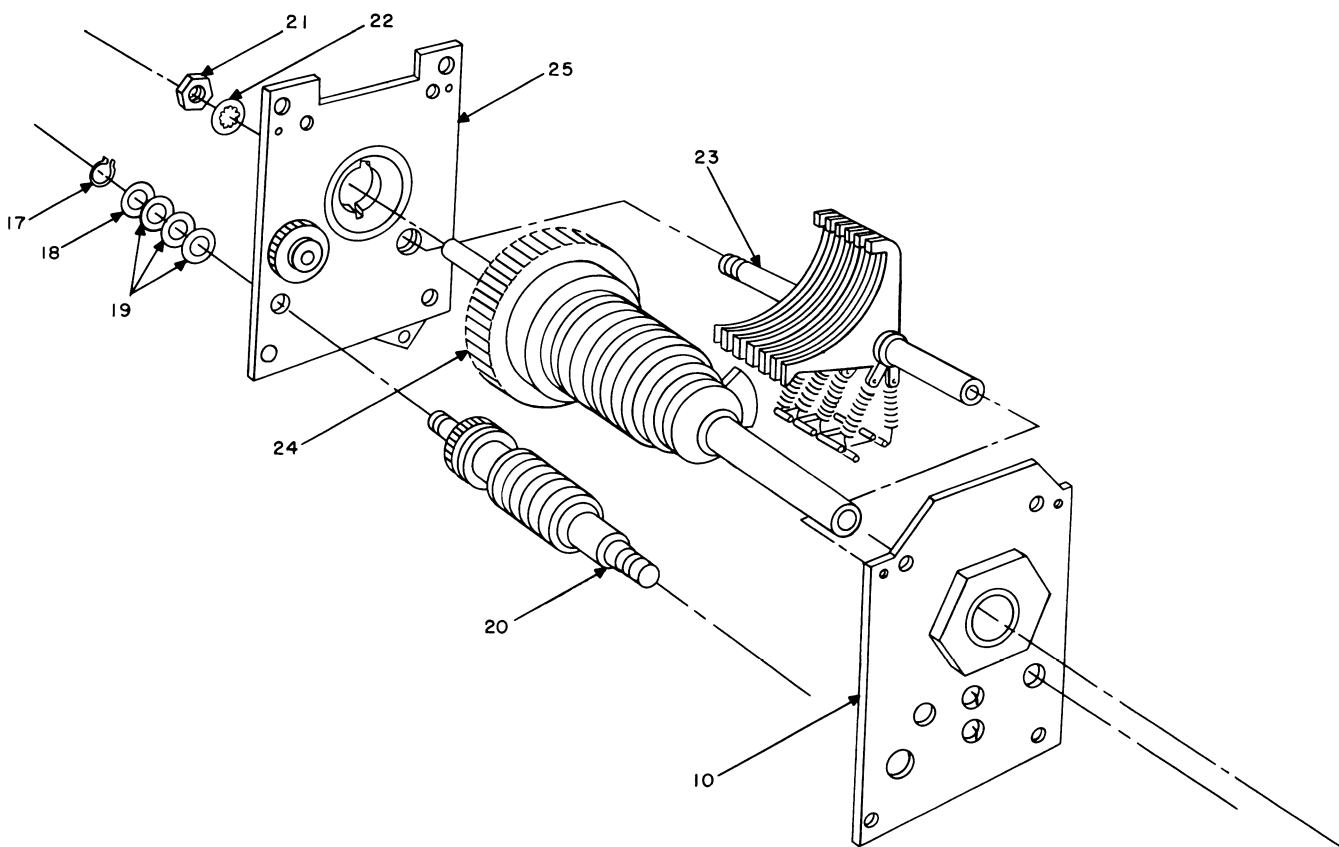

Figure 113. Disassembly of Autotune singleturn head



Assembly of Autotune singleturn head

TM 806-107

390412 O - 56 (In pocket) No. 15

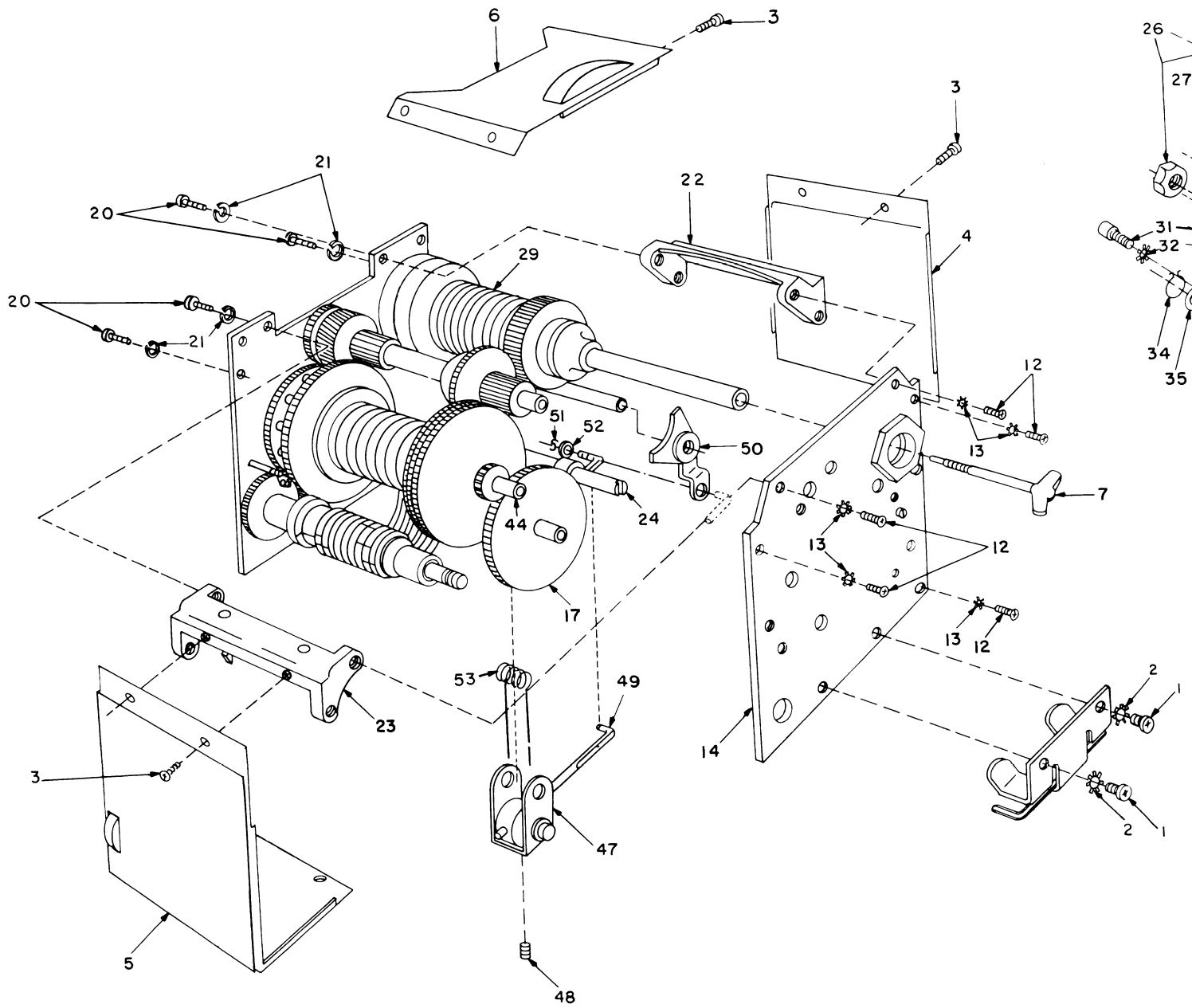
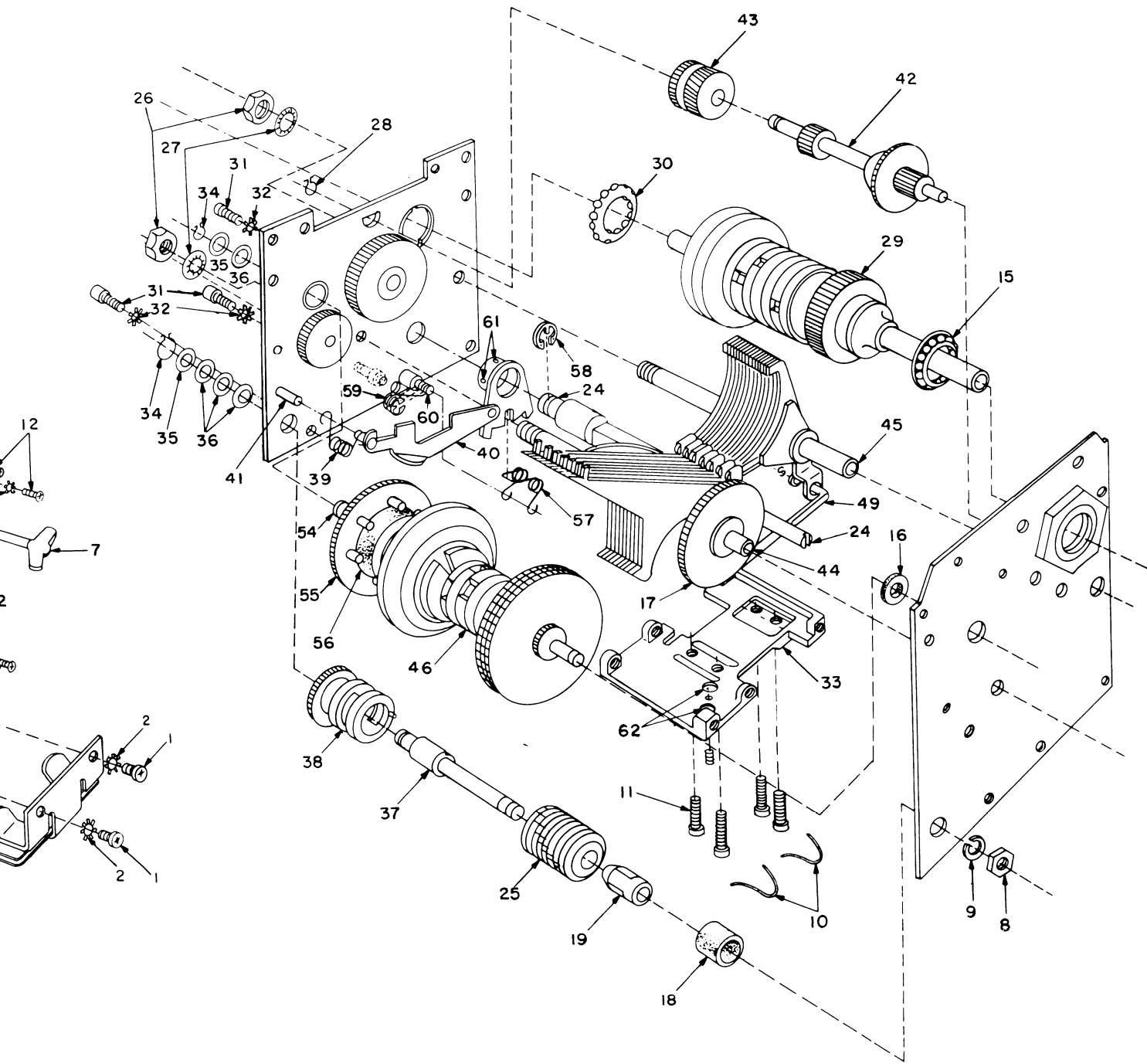

Figure 114. Disassembly of Autotune



Disassembly of Autotune multiturn head.

TM 806-105

390412 O - 56 (In pocket) No. 16

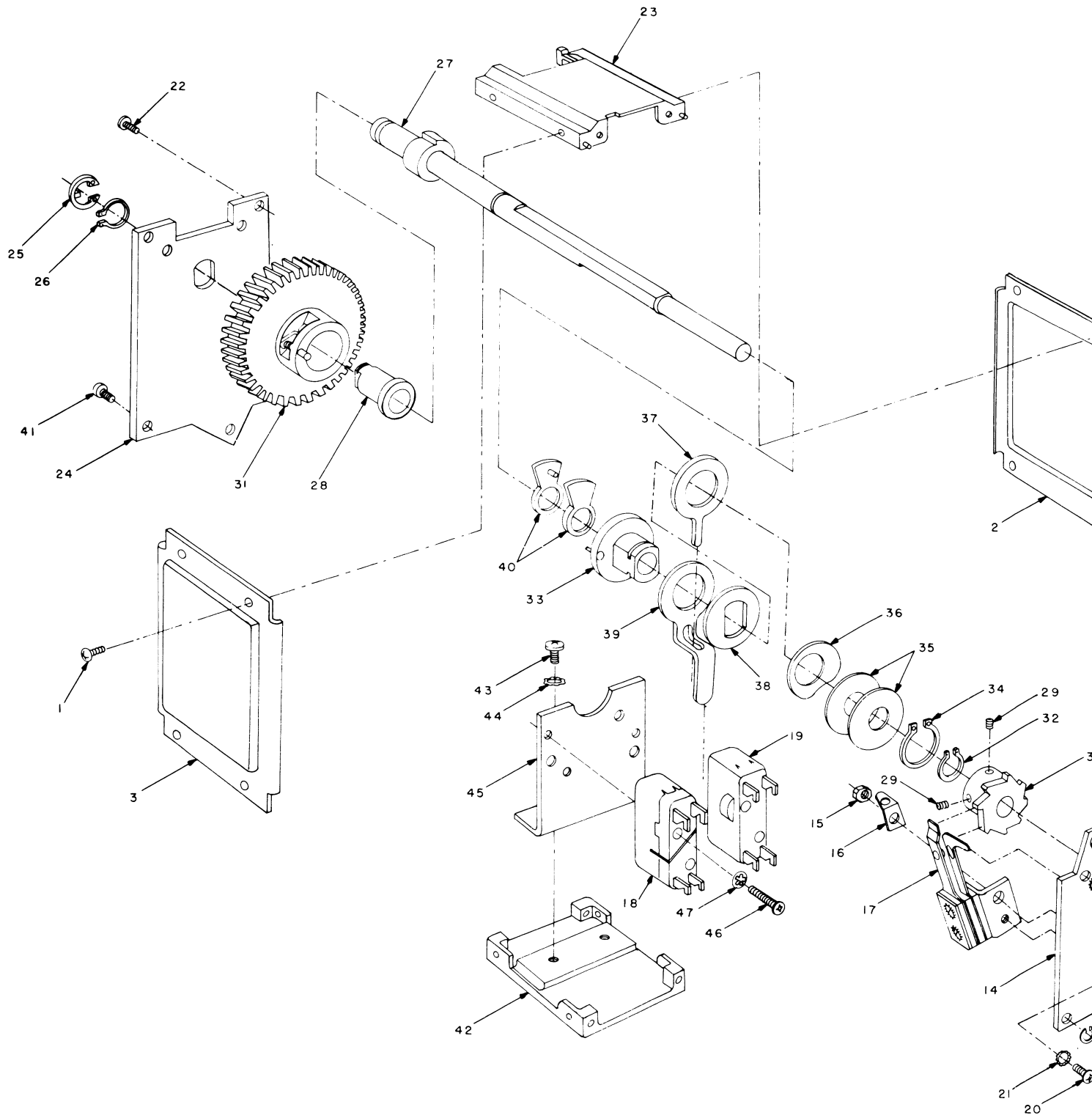
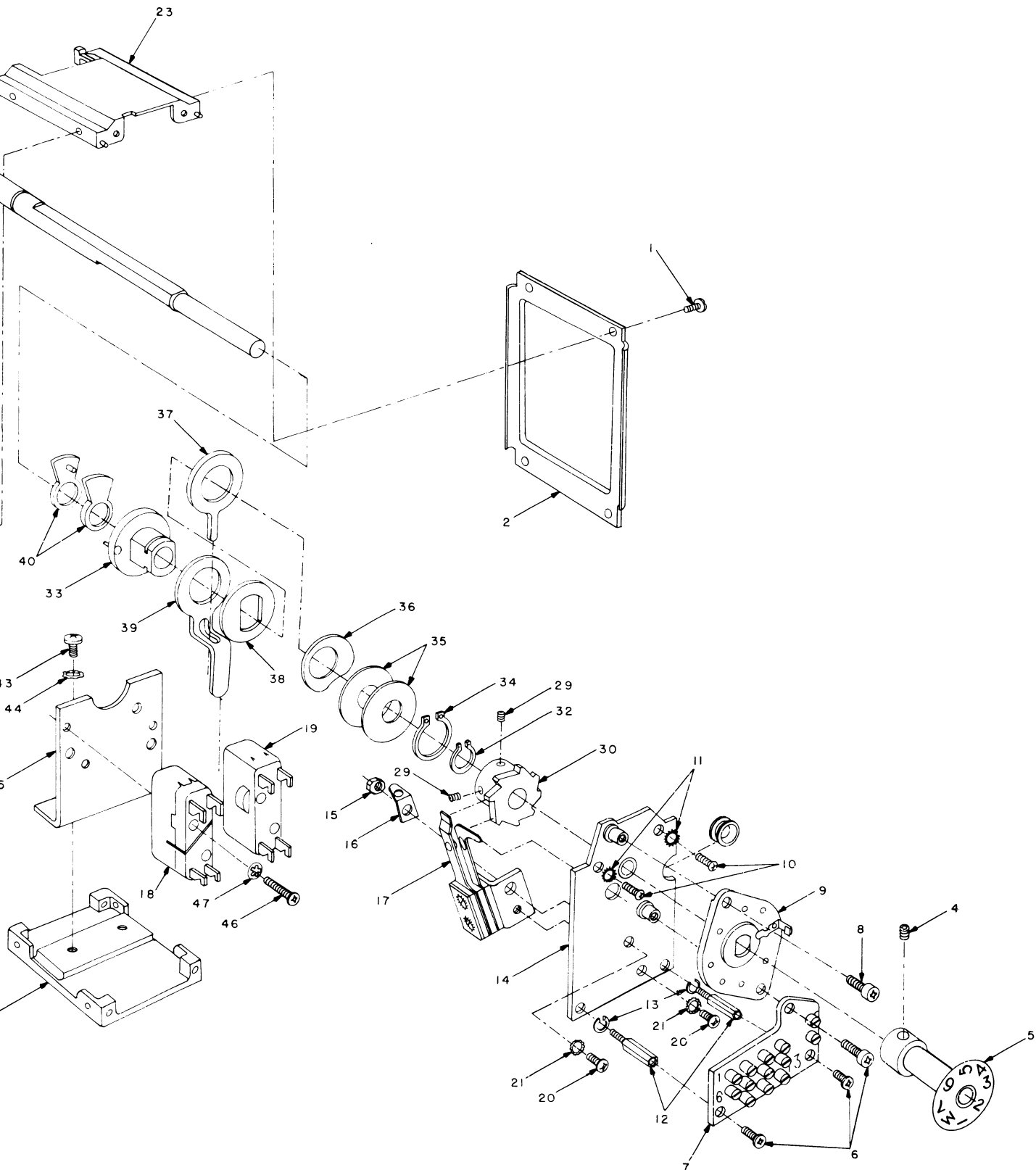

Figure 115. Disassembly of Autotune control head.



TM 806-106

Figure 115. Disassembly of Autotune control head.

390412 O - 56 (In pocket) No. 17

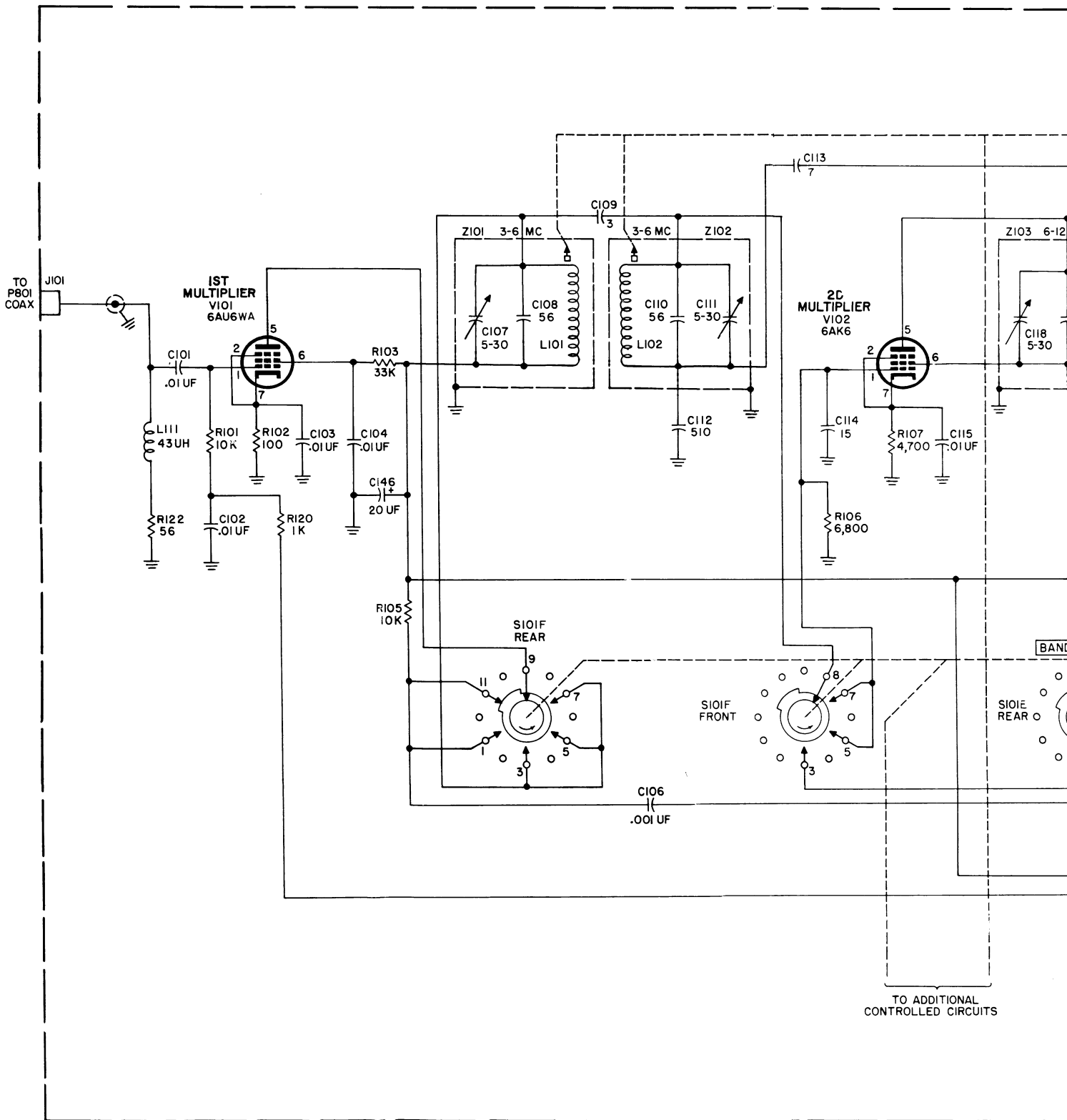

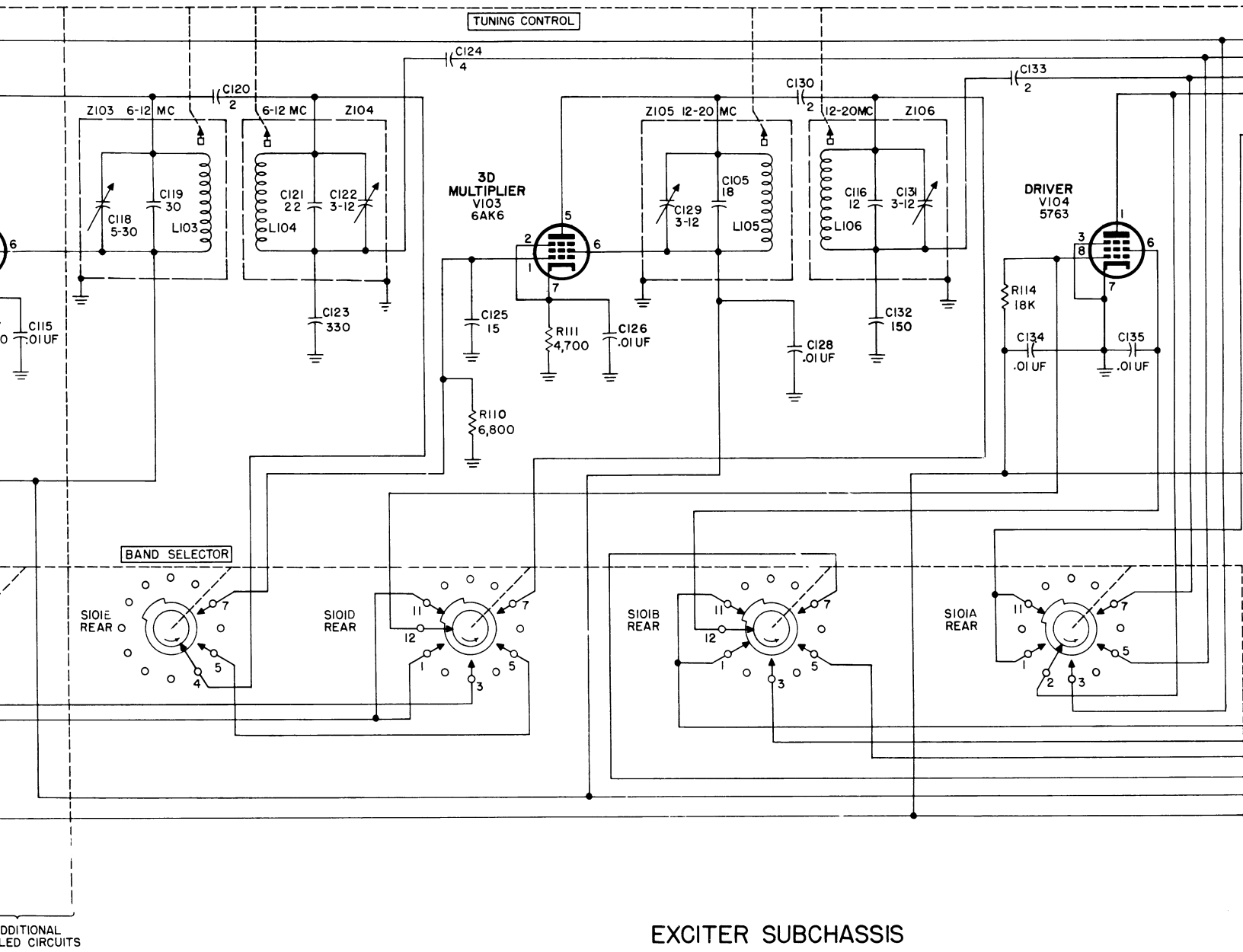

EXCITER SUBCHASSIS

Figure 130. Exciter subchassis, schematic diagram.

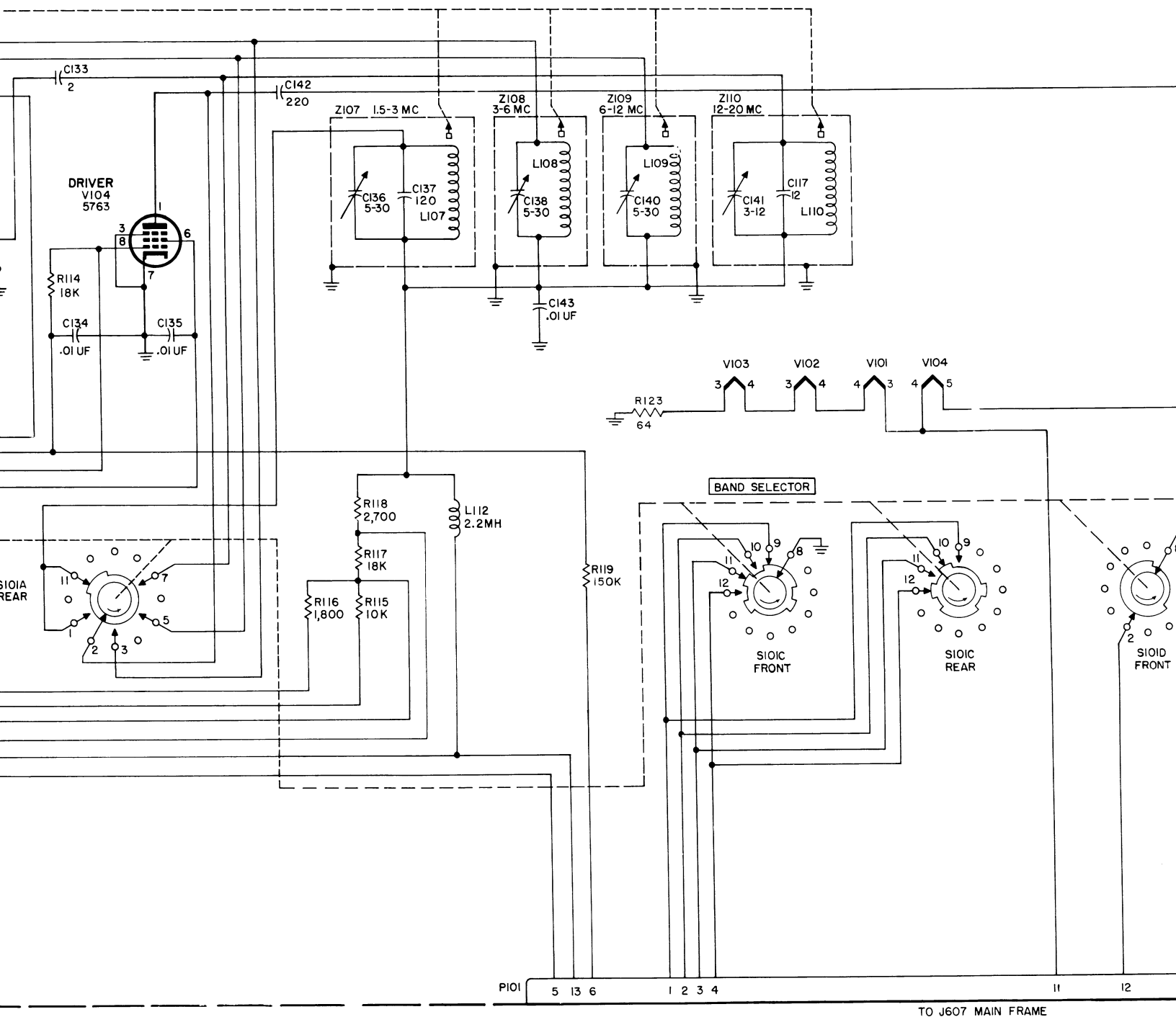

chassis, schematic diagram.

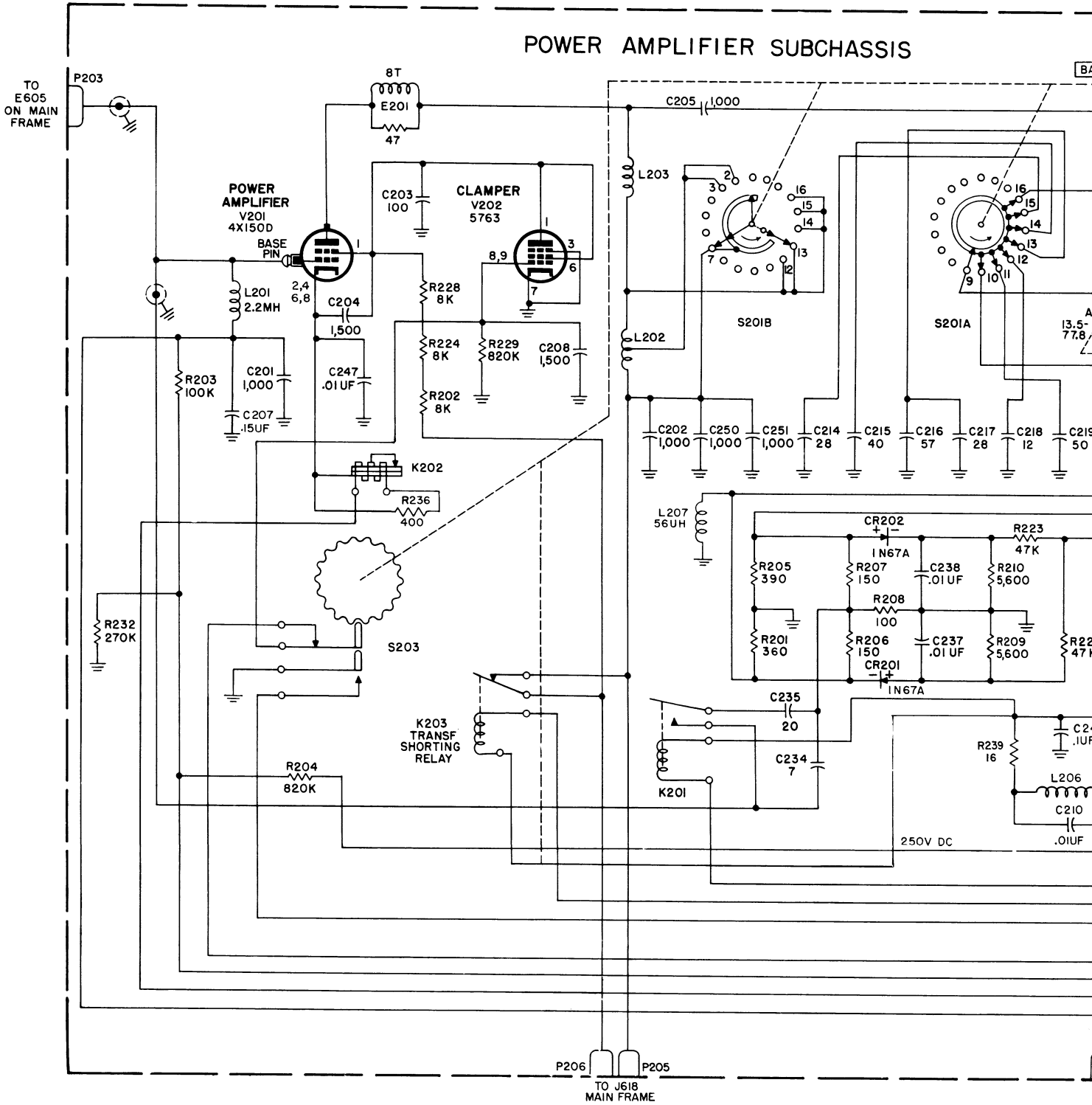
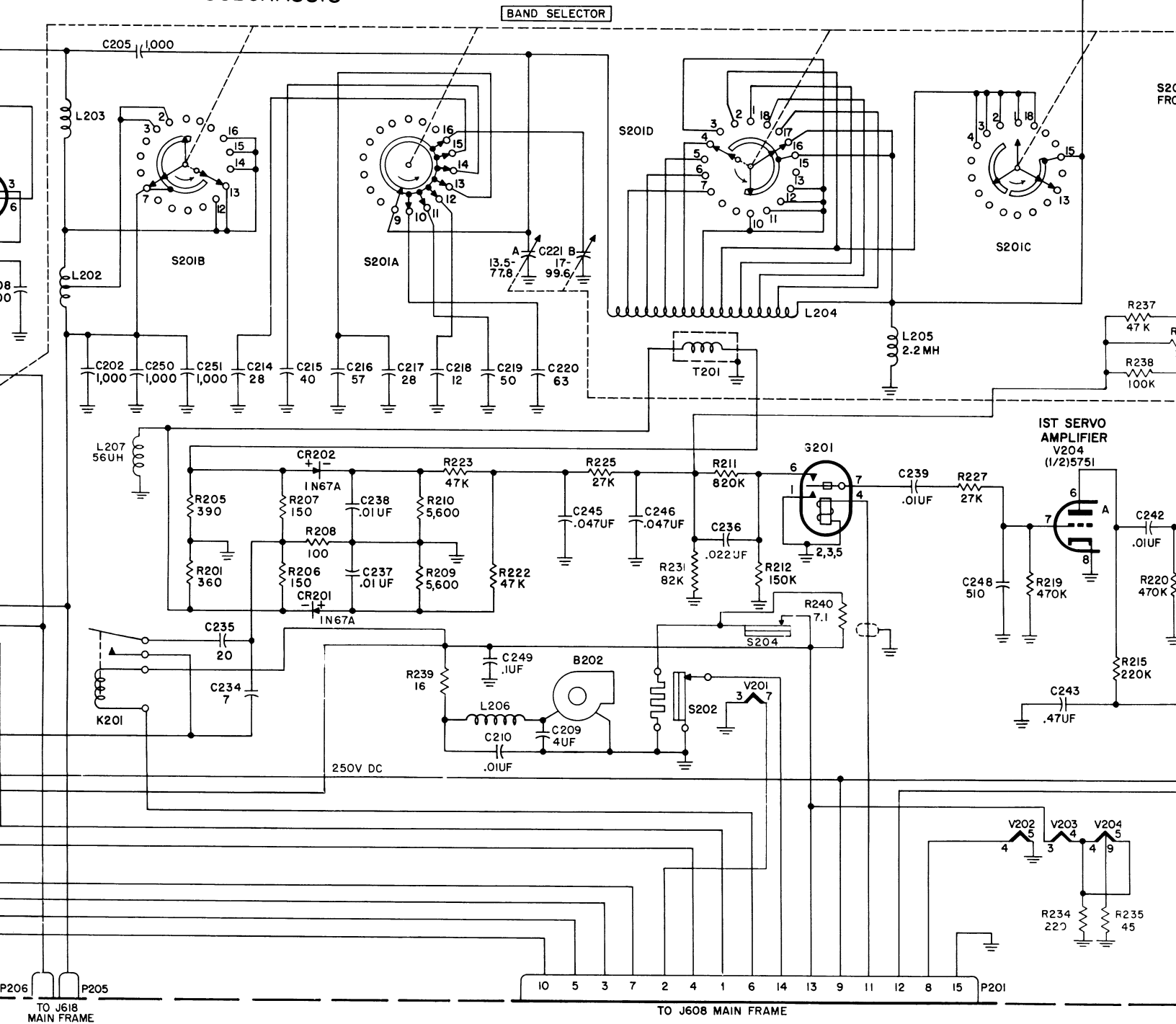

Figure 131. Power a

POWER AMPLIFIER SUBCHASSIS



1. UNL
R
C
2. S20
REA
FOR

Figure 131. Power amplifier subchassis, schematic diagram.

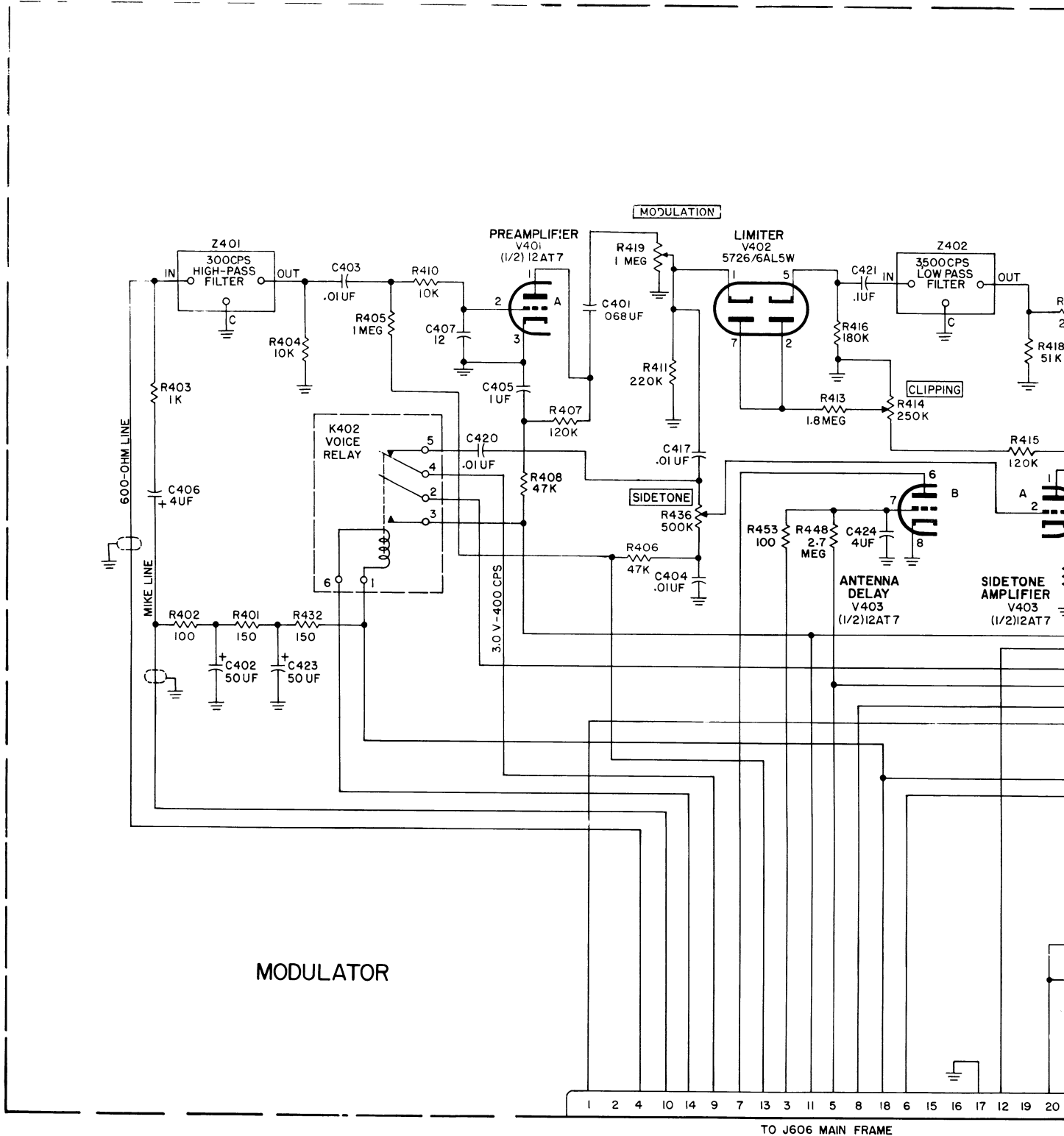

MODULATOR

TO J606 MAIN FRAME

Figure 132. Modulator subcircuit

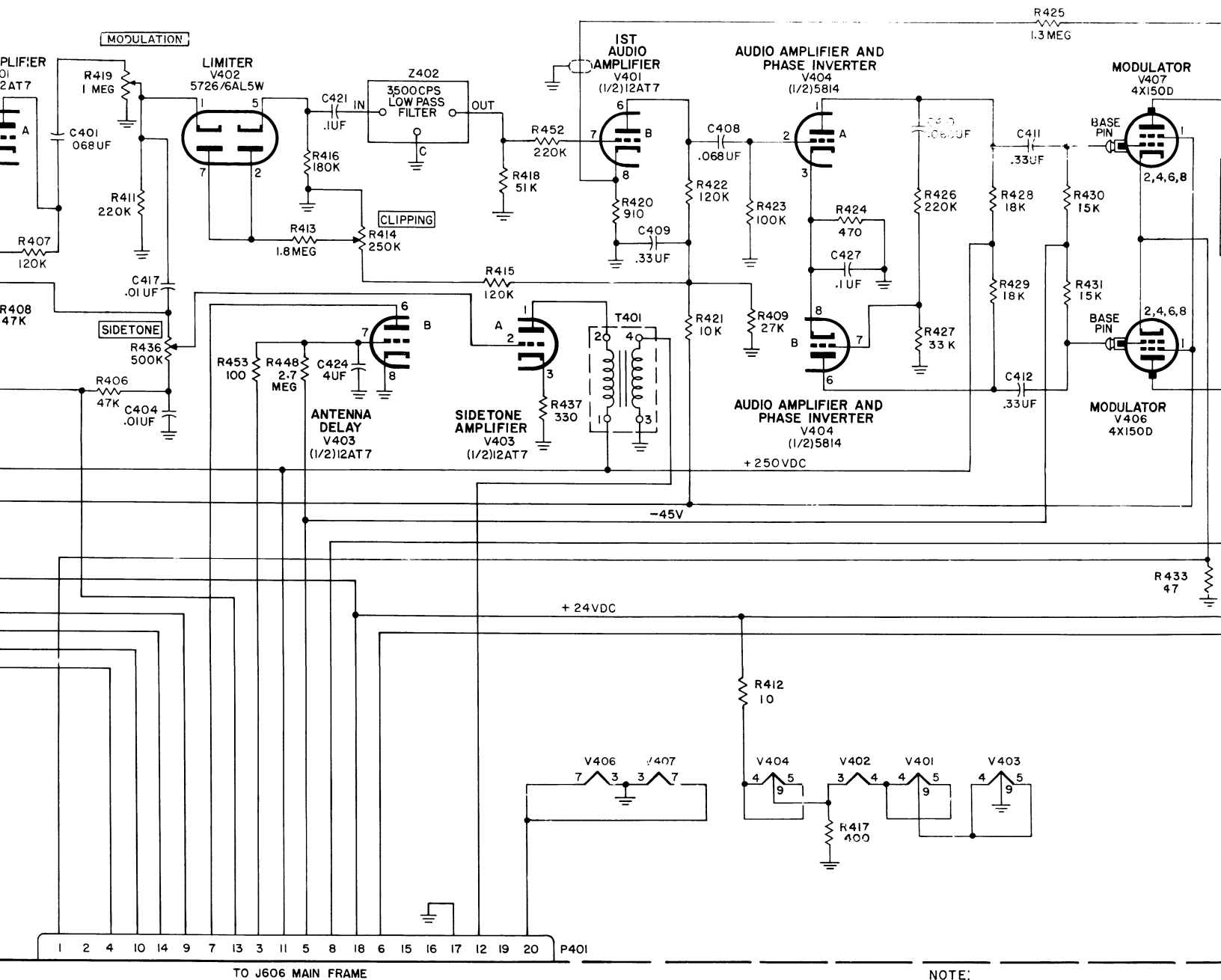
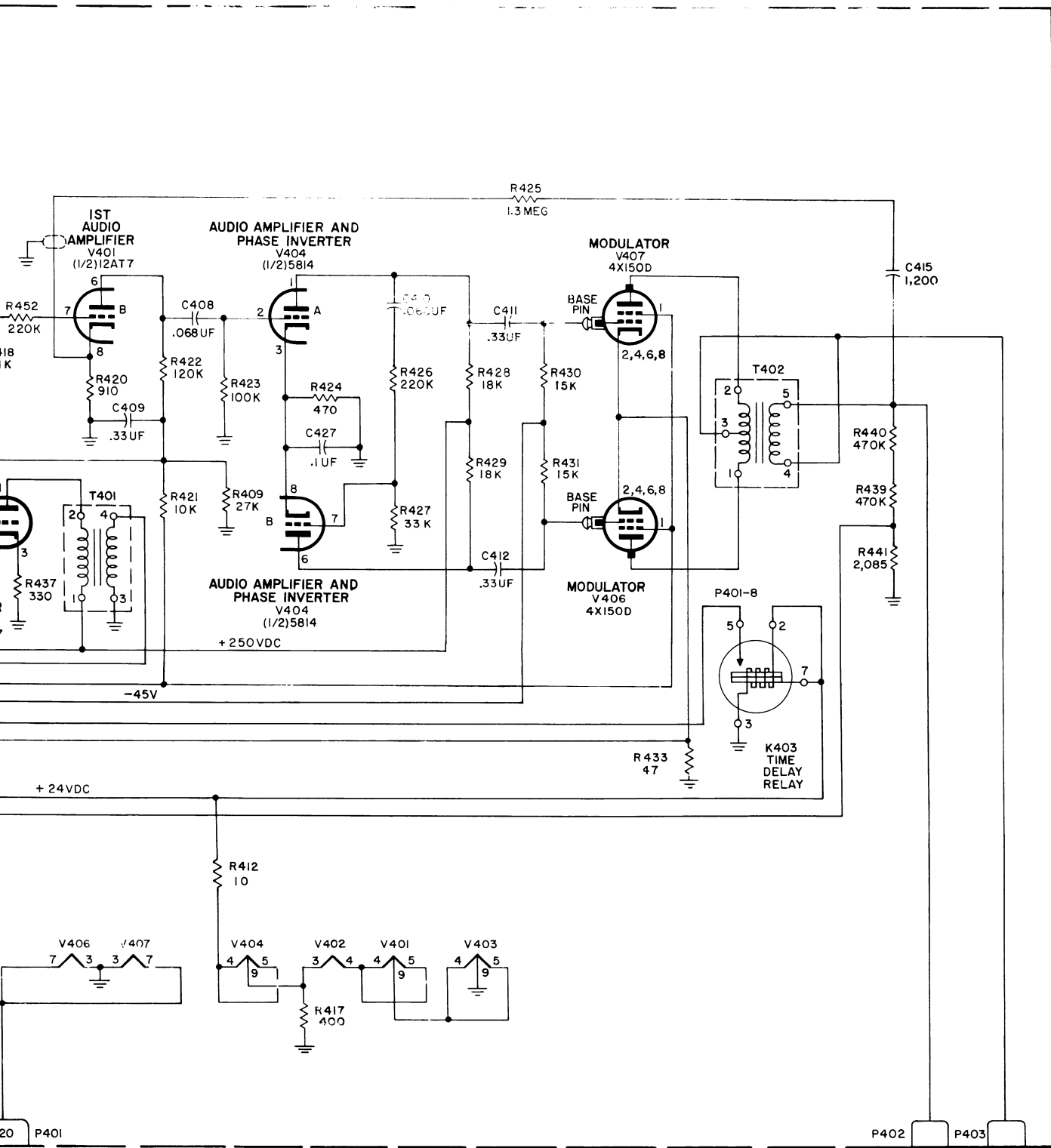

Figure 132. Modulator subchassis, schematic diagram.



NOTE:
UNLESS OTHERWISE SHOWN:
RESISTORS ARE IN OHMS.
CAPACITORS ARE IN UUF

TO J619
MAIN FRAME

TM806-130

chassis, schematic diagram.

390412 O - 56 (In pocket) No. 20

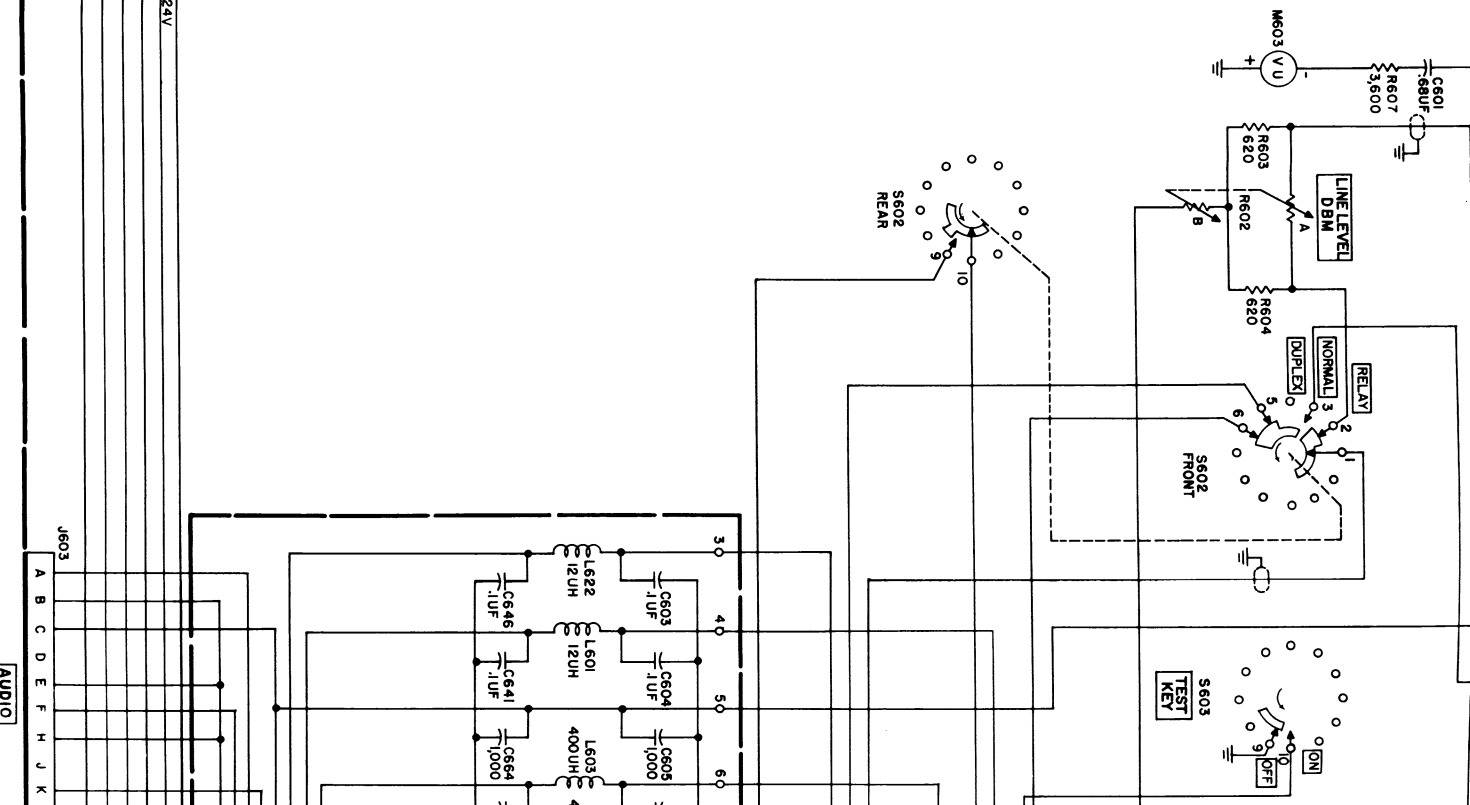
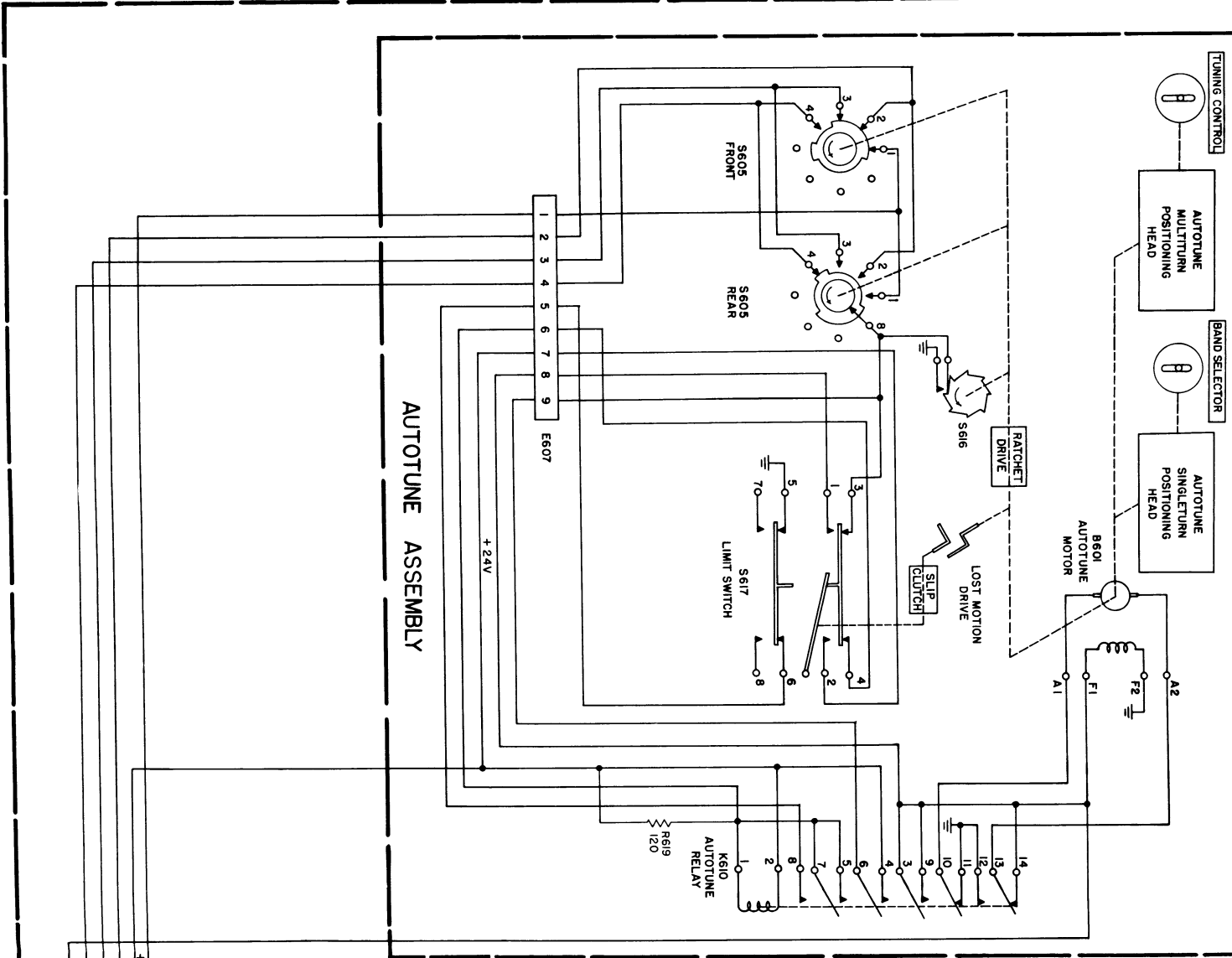

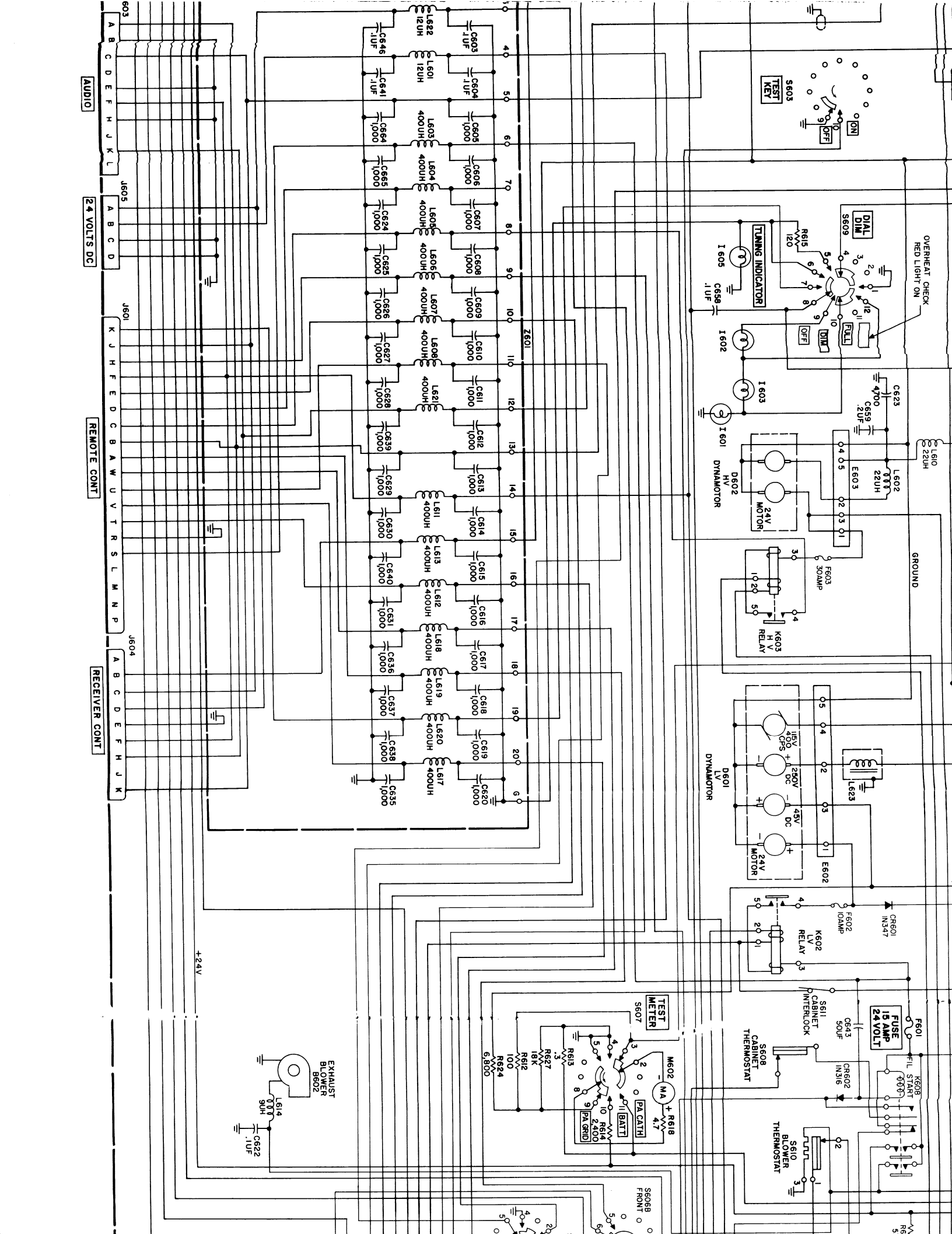

AUDIO

24 VOLTS DC

REMOTE CONT

RECEIVER CONT

603
A B C D E F H J K L
605
A B C D
601
K J H F E D C B A W U V T R S L M N P
604
A B C D E F H J K

+24V

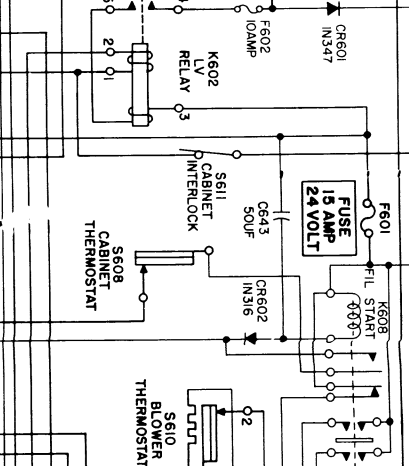
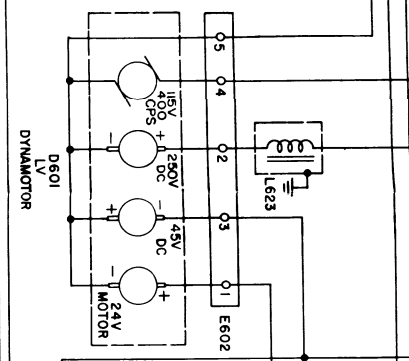
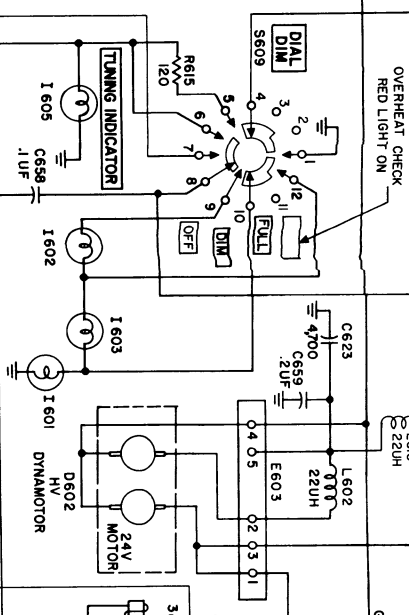
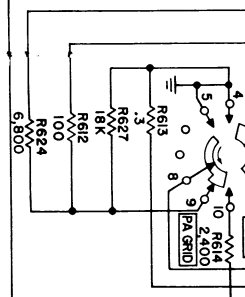
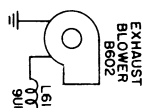

TEST KEY

OVERHEAT CHECK
RED LIGHT ON

GROUND

5

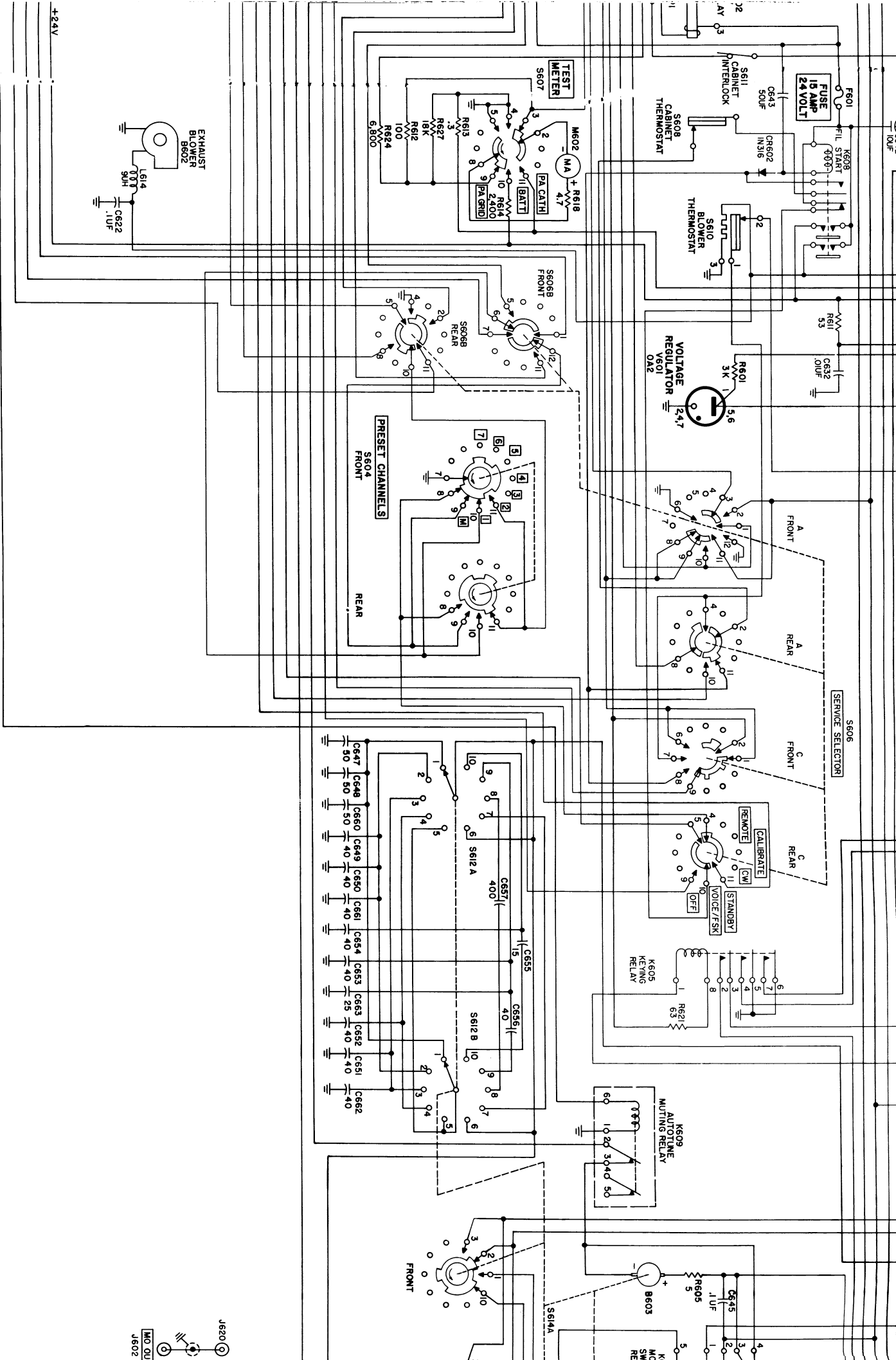

J620 ()
 MO DU J602 ()

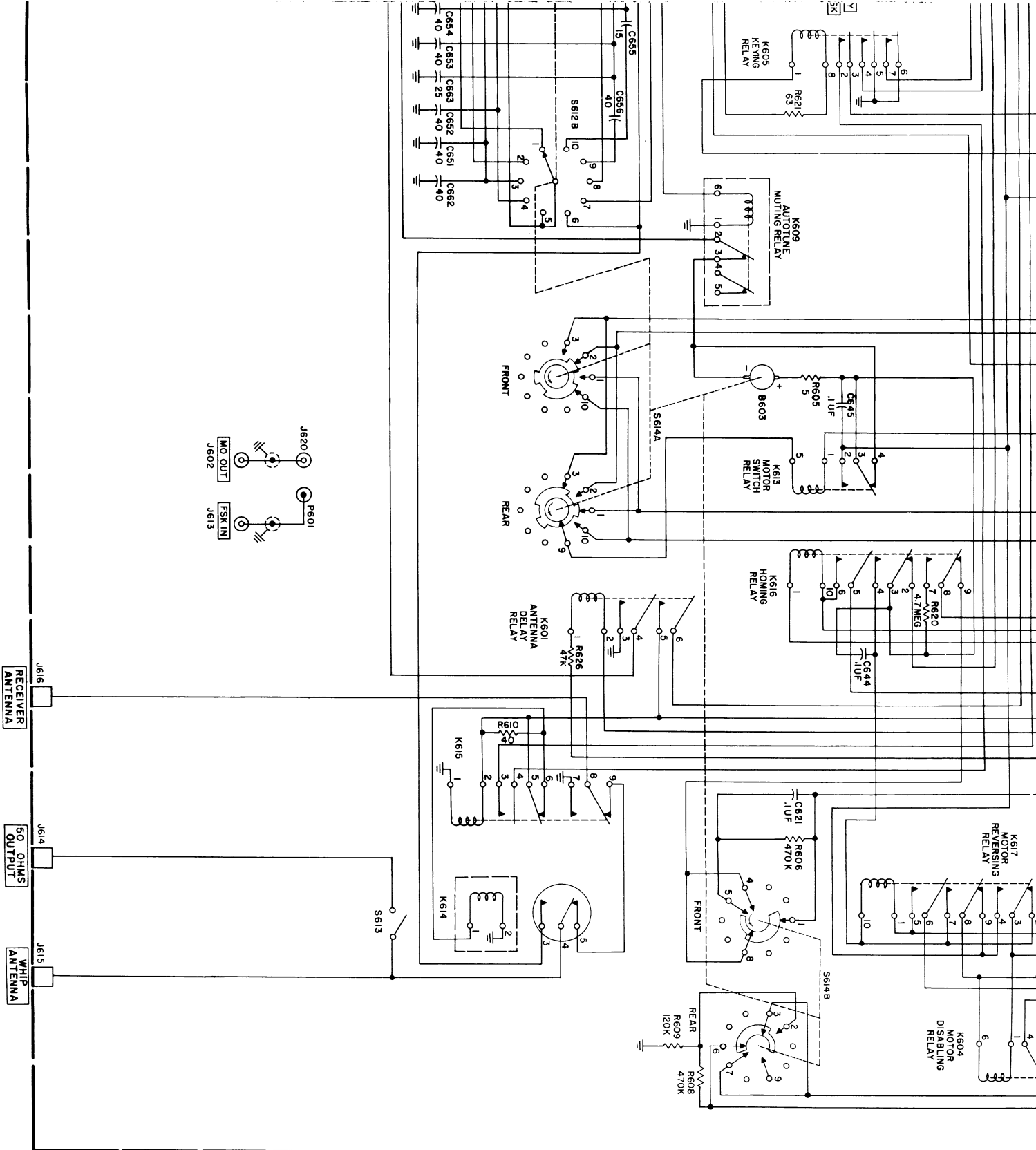

- NOTES:
1. UNLESS OTHERWISE SHOWN: RESISTORS ARE IN OHMS; CAPACITORS ARE IN UUF.
 2. ALL SWITCHES ARE VIEWED FROM THE REAR OF THE EQUIPMENT.
 3. SWITCHES ARE SHOWN IN THEIR FULL COUNTERCLOCKWISE POSITIONS, 7 MC RANGE FOR THE 1.5 TO 1.7 MC RANGE.
 4. RELAYS ARE SHOWN IN THEIR NORMAL POSITIONS WITH POWER REMOVED.

MAIN FRAME

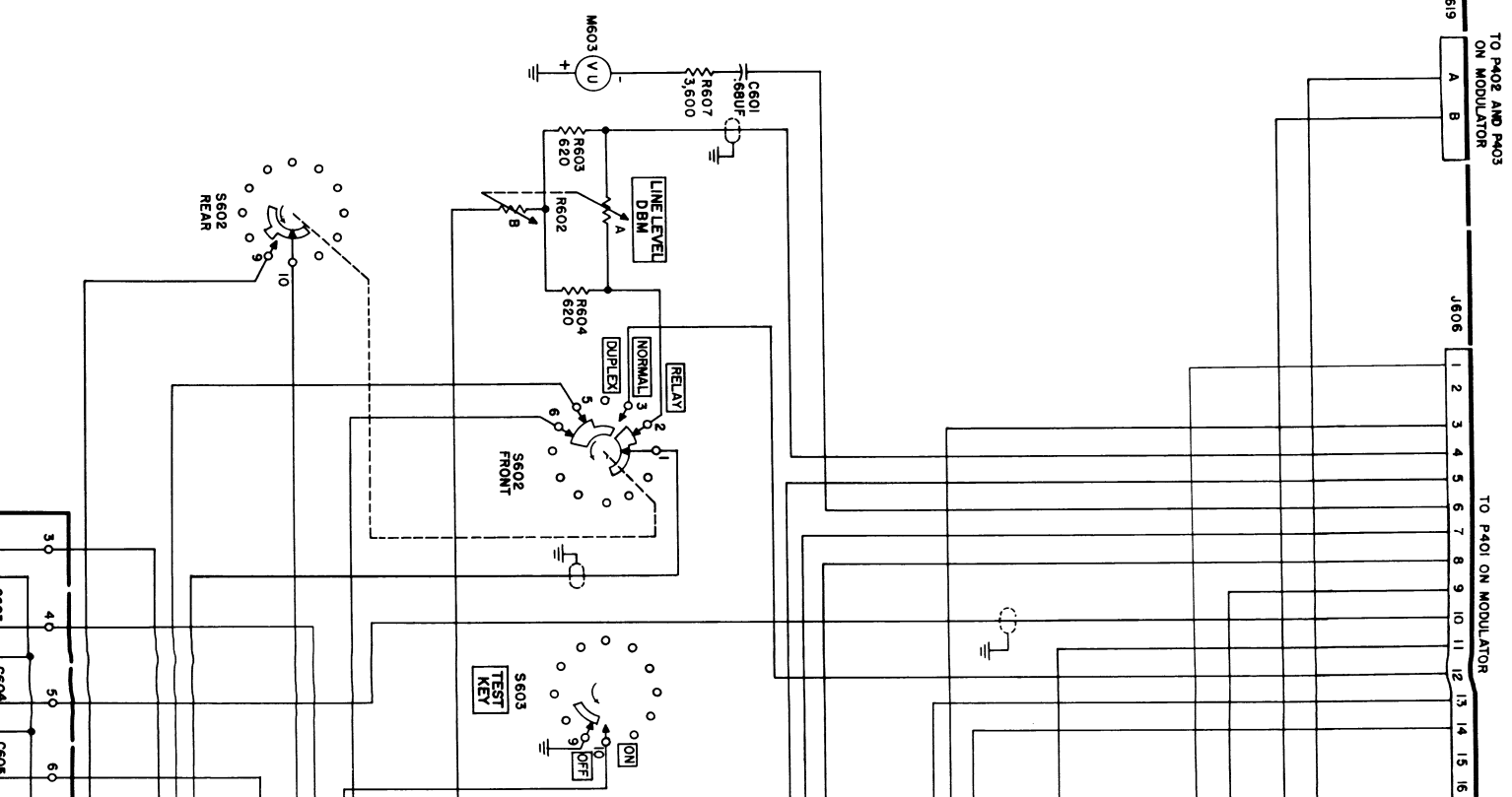
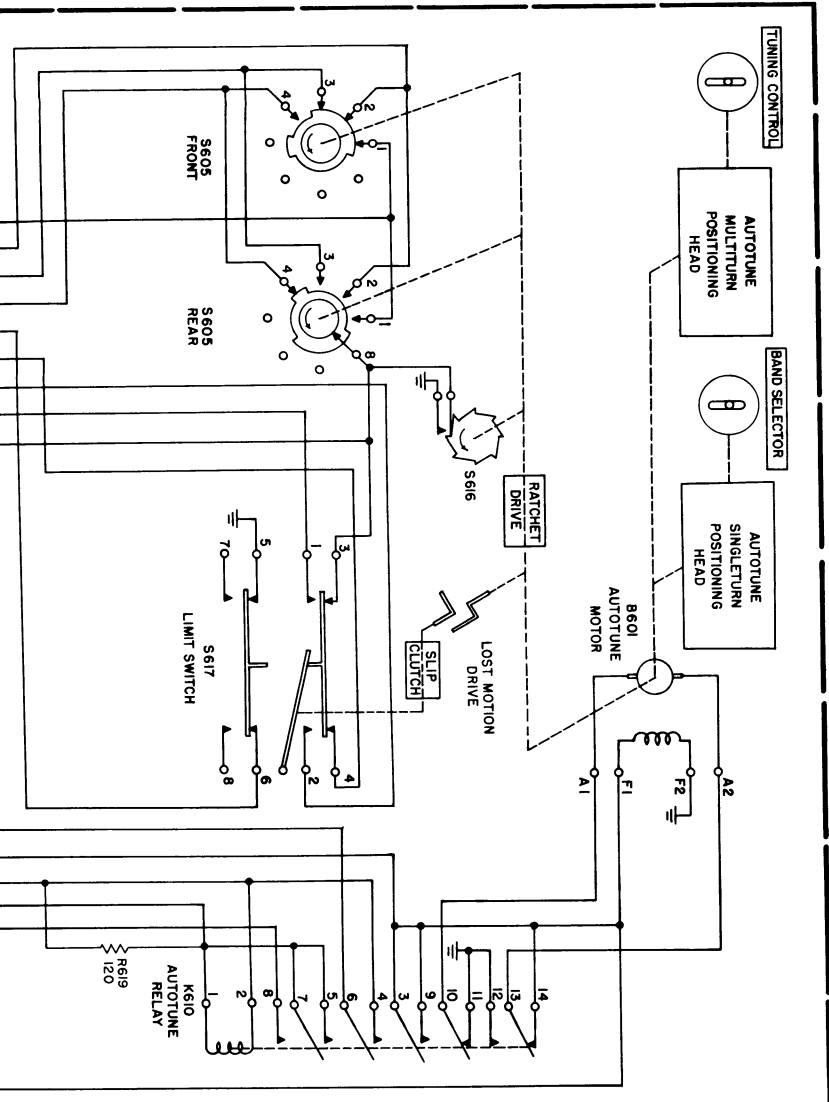

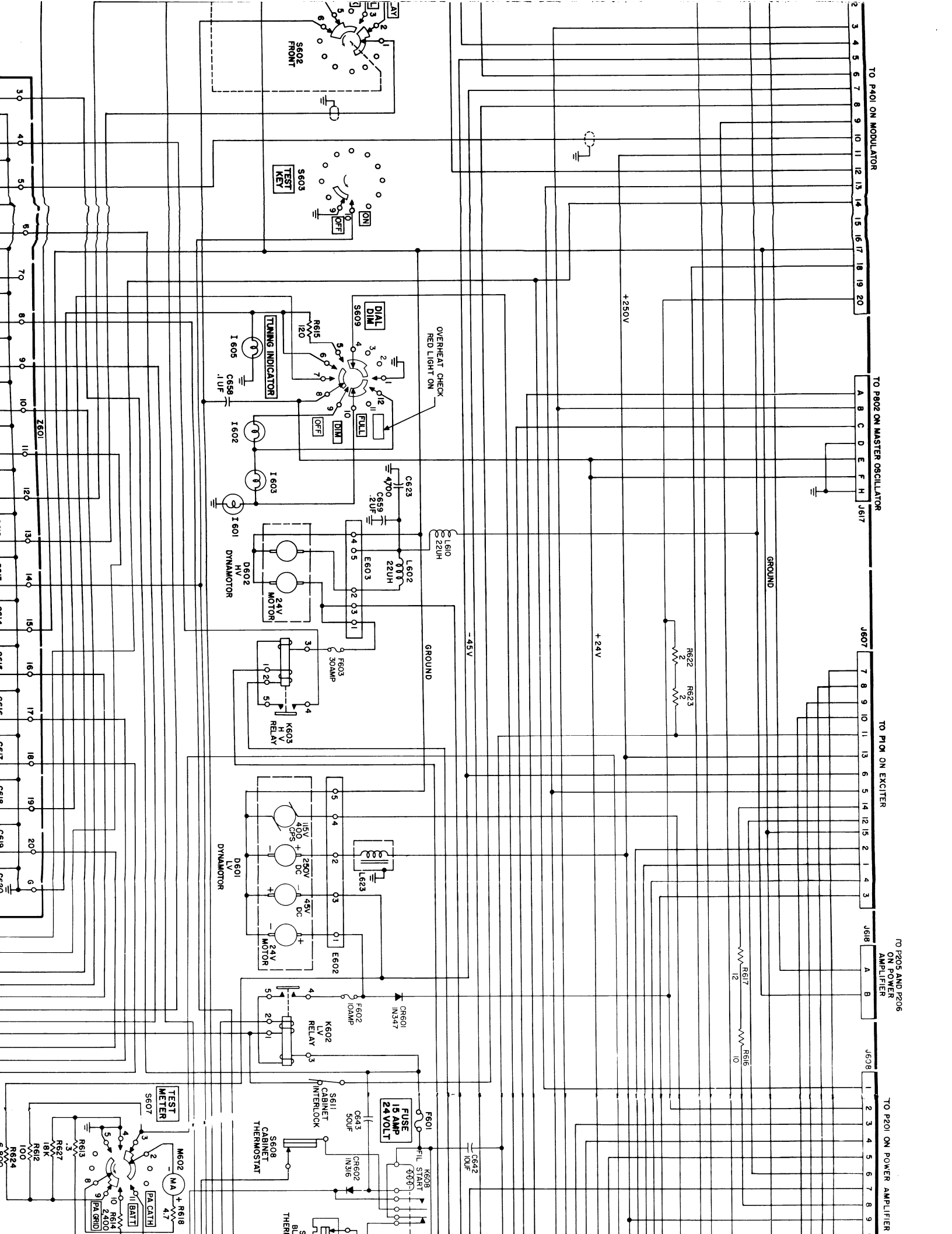

TO P401 ON MODULATOR

TO P902 ON MASTER OSCILLATOR

TO P101 ON EXCITER

TO P205 AND P206 ON POWER AMPLIFIER

TO P201 ON POWER AMPLIFIER

1 2 3 4 5 6 7 8 9 10 11 12 13 14 15 16 17 18 19 20

A B C D E F H

1607

7 8 9 10 11 13 6 5 14 12 15 2 1 4 3

1608

1608B

1 2 3 4 5 6 7 8 9

GROUND

+250V

+24V

-45V

GROUND

GROUND

GROUND

GROUND

GROUND

S602 FRONT

S603 TEST KEY

DIAL DIM S609

TUNING INDICATOR I 605

OVERHEAT CHECK RED LIGHT ON

FULL DIM OFF

D602 HV MOTOR

24V MOTOR

K603 HV RELAY

D601 LV DYNAMOTOR

24V MOTOR

K602 LV RELAY

TEST METER S607

M602 MA

RE18

S608 CABINET THERMOSTAT

S611 CABINET INTERLOCK

FUSE 15 AMP 24VOLT

K608 FUL START

C642 10UF

C643 50UF

C644 50UF

C645 50UF

C646 50UF

C647 50UF

C648 50UF

C649 50UF

C650 50UF

C651 50UF

C652 50UF

C653 50UF

C654 50UF

C655 50UF

C656 50UF

C657 50UF

C658 50UF

C659 50UF

C660 50UF

C661 50UF

C662 50UF

C663 50UF

C664 50UF

C665 50UF

C666 50UF

C667 50UF

C668 50UF

C669 50UF

C670 50UF

C671 50UF

C672 50UF

C673 50UF

C674 50UF

C675 50UF

C676 50UF

C677 50UF

C678 50UF

C679 50UF

C680 50UF

C681 50UF

C682 50UF

C683 50UF

C684 50UF

C685 50UF

C686 50UF

C687 50UF

C688 50UF

C689 50UF

C690 50UF

C691 50UF

C692 50UF

C693 50UF

C694 50UF

C695 50UF

C696 50UF

C697 50UF

C698 50UF

C699 50UF

C700 50UF

C701 50UF

C702 50UF

C703 50UF

C704 50UF

C705 50UF

C706 50UF

C707 50UF

C708 50UF

C709 50UF

C710 50UF

C711 50UF

C712 50UF

C713 50UF

C714 50UF

C715 50UF

C716 50UF

C717 50UF

C718 50UF

C719 50UF

C720 50UF

C721 50UF

C722 50UF

C723 50UF

C724 50UF

C725 50UF

C726 50UF

C727 50UF

C728 50UF

C729 50UF

C730 50UF

C731 50UF

C732 50UF

C733 50UF

C734 50UF

C735 50UF

C736 50UF

C737 50UF

C738 50UF

C739 50UF

C740 50UF

C741 50UF

C742 50UF

C743 50UF

C744 50UF

C745 50UF

C746 50UF

C747 50UF

C748 50UF

C749 50UF

C750 50UF

C751 50UF

C752 50UF

C753 50UF

C754 50UF

C755 50UF

C756 50UF

C757 50UF

C758 50UF

C759 50UF

C760 50UF

C761 50UF

C762 50UF

C763 50UF

C764 50UF

C765 50UF

C766 50UF

C767 50UF

C768 50UF

C769 50UF

C770 50UF

C771 50UF

C772 50UF

C773 50UF

C774 50UF

C775 50UF

C776 50UF

C777 50UF

C778 50UF

C779 50UF

C780 50UF

C781 50UF

C782 50UF

C783 50UF

C784 50UF

C785 50UF

C786 50UF

C787 50UF

C788 50UF

C789 50UF

C790 50UF

C791 50UF

C792 50UF

C793 50UF

C794 50UF

C795 50UF

C796 50UF

C797 50UF

C798 50UF

C799 50UF

C800 50UF

C801 50UF

C802 50UF

C803 50UF

C804 50UF

C805 50UF

C806 50UF

C807 50UF

C808 50UF

C809 50UF

C810 50UF

C811 50UF

C812 50UF

C813 50UF

C814 50UF

C815 50UF

C816 50UF

C817 50UF

C818 50UF

C819 50UF

C820 50UF

C821 50UF

C822 50UF

C823 50UF

C824 50UF

C825 50UF

C826 50UF

C827 50UF

C828 50UF

C829 50UF

C830 50UF

C831 50UF

C832 50UF

C833 50UF

C834 50UF

C835 50UF

C836 50UF

C837 50UF

C838 50UF

C839 50UF

C840 50UF

C841 50UF

C842 50UF

C843 50UF

C844 50UF

C845 50UF

C846 50UF

C847 50UF

C848 50UF

C849 50UF

C850 50UF

C851 50UF

C852 50UF

C853 50UF

C854 50UF

C855 50UF

C856 50UF

C857 50UF

C858 50UF

C859 50UF

C860 50UF

C861 50UF

C862 50UF

C863 50UF

C864 50UF

C865 50UF

C866 50UF

C867 50UF

C868 50UF

C869 50UF

C870 50UF

C871 50UF

C872 50UF

C873 50UF

C874 50UF

C875 50UF

C876 50UF

C877 50UF

C878 50UF

C879 50UF

C880 50UF

C881 50UF

C882 50UF

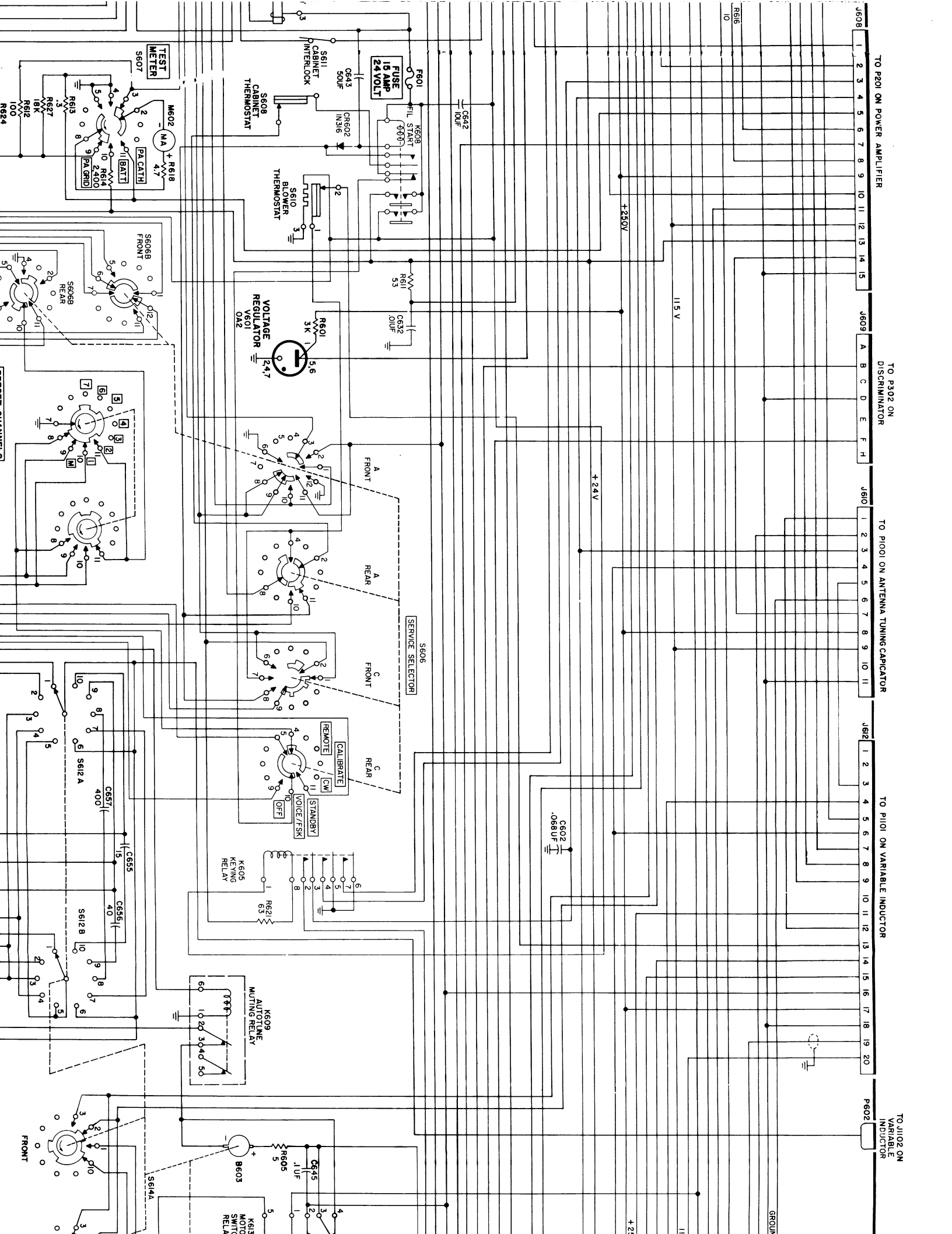

TO P201 ON POWER AMPLIFIER

TO P302 ON DISCRIMINATOR

TO P1001 ON ANTENNA TUNING CAPACITOR

TO P101 ON VARIABLE INDUCTOR

TO J102 ON VARIABLE INDUCTOR

J608 1 2 3 4 5 6 7 8 9 10 11 12 13 14 15

J609 A B C D E F H

J610 1 2 3 4 5 6 7 8 9 10 11

J612 1 2 3 4 5 6 7 8 9 10 11 12 13 14 15 16 17 18 19 20

P602

GROUND

+250V

115 V

+24V

.058UF

+21

11

FUSE
15 AMP
24 VOLT

VOLTAGE
REGULATOR
V601
0A2

TEST
METER
S607

S608
CABINET
THERMOSTAT

S610
BLOWER
THERMOSTAT

A
FRONT

A
REAR

C
FRONT

C
REAR

S606
SERVICE SELECTOR

REMOTE
CALIBRATE
CW
STANDBY
VOICE/SSK
OFF

K605
KEYS
RELAY

K609
AUTOTUNE
MULTIPLY RELAY

K618
MUSIC
SWITCH RELAY

S614A

FRONT

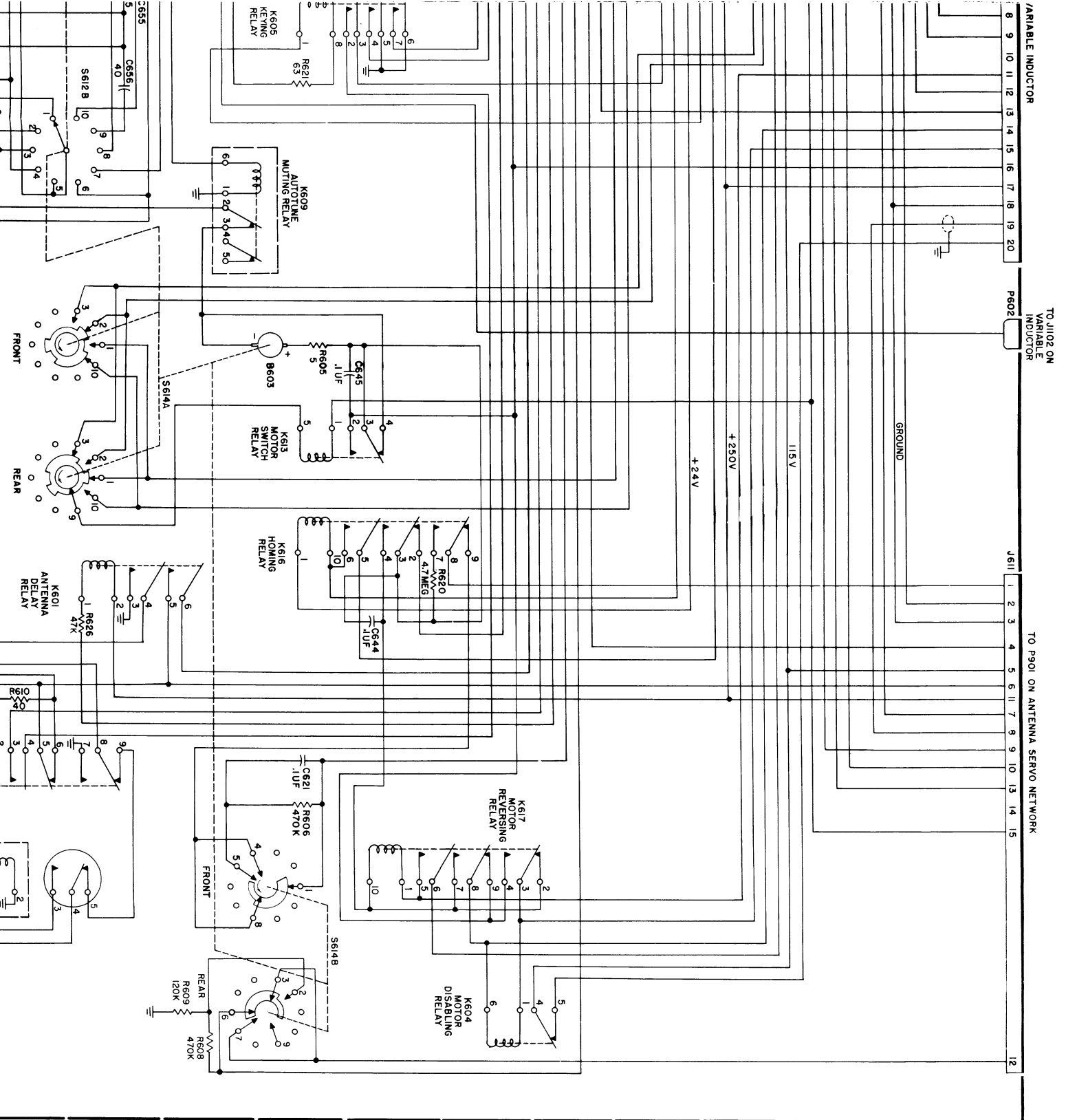

NOTES:

- 1 UNLESS OTHERWISE SHOWN: RESISTORS ARE IN OHMS; CAPACITORS ARE IN UUF.
- 2 ALL SWITCHES ARE VIEWED FROM THE REAR OF THE EQUIPMENT.
- 3 SWITCHES ARE SHOWN IN THEIR FULL COUNTERCLOCKWISE POSITIONS, OR POSITIONED FOR THE 1.5 TO 1.7 MC RANGE.
- 4 RELAYS ARE SHOWN IN THEIR NORMAL POSITIONS WITH POWER REMOVED.

VARIABLE INDUCTOR

TO J102 ON VARIABLE INDUCTOR

TO P901 ON ANTENNA SERVO NETWORK

12

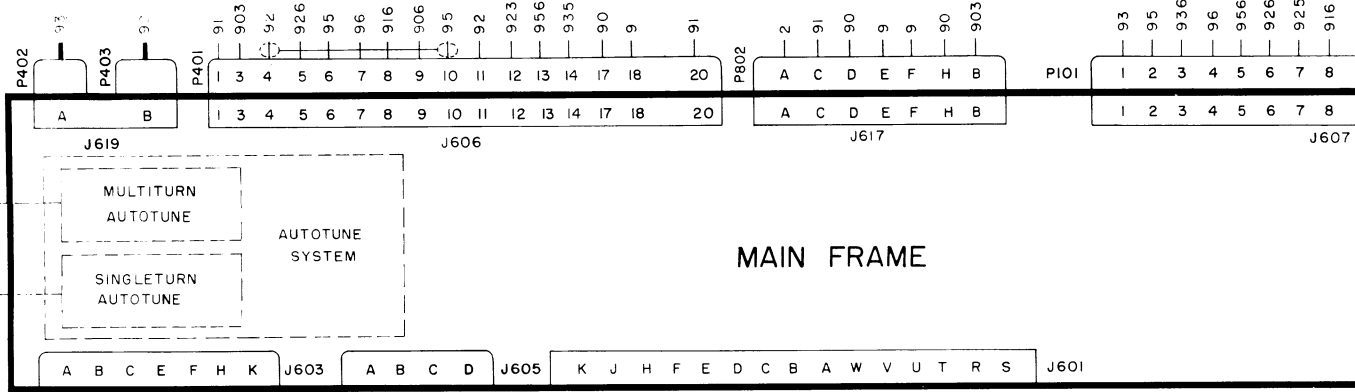
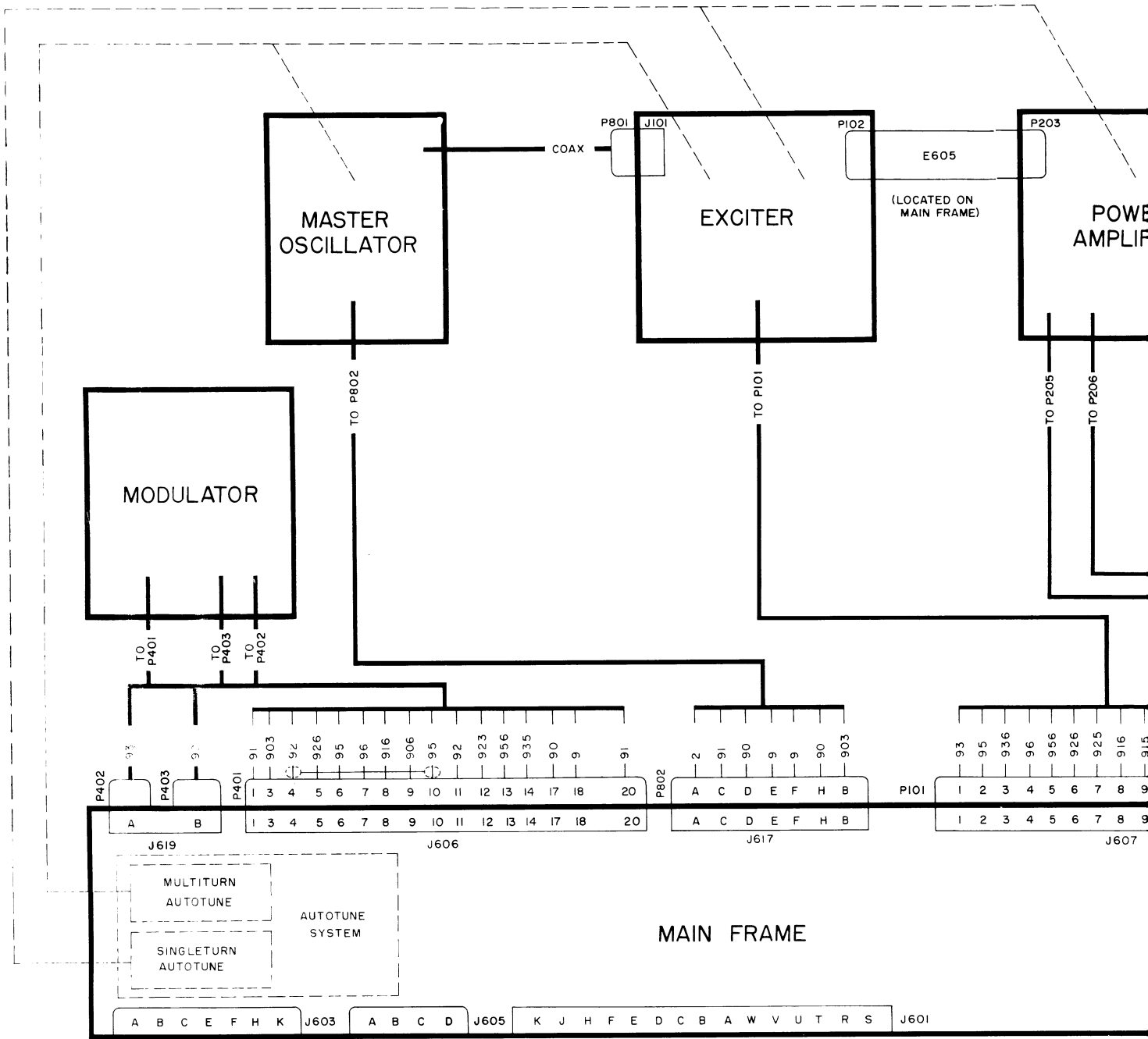

AUDIO

24 VOLTS
DC

REMOTE CONT

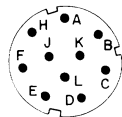

AUDIO
J603

P401, P101

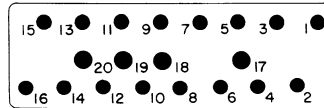

J606, J612

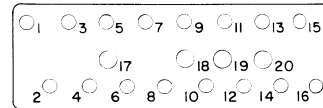

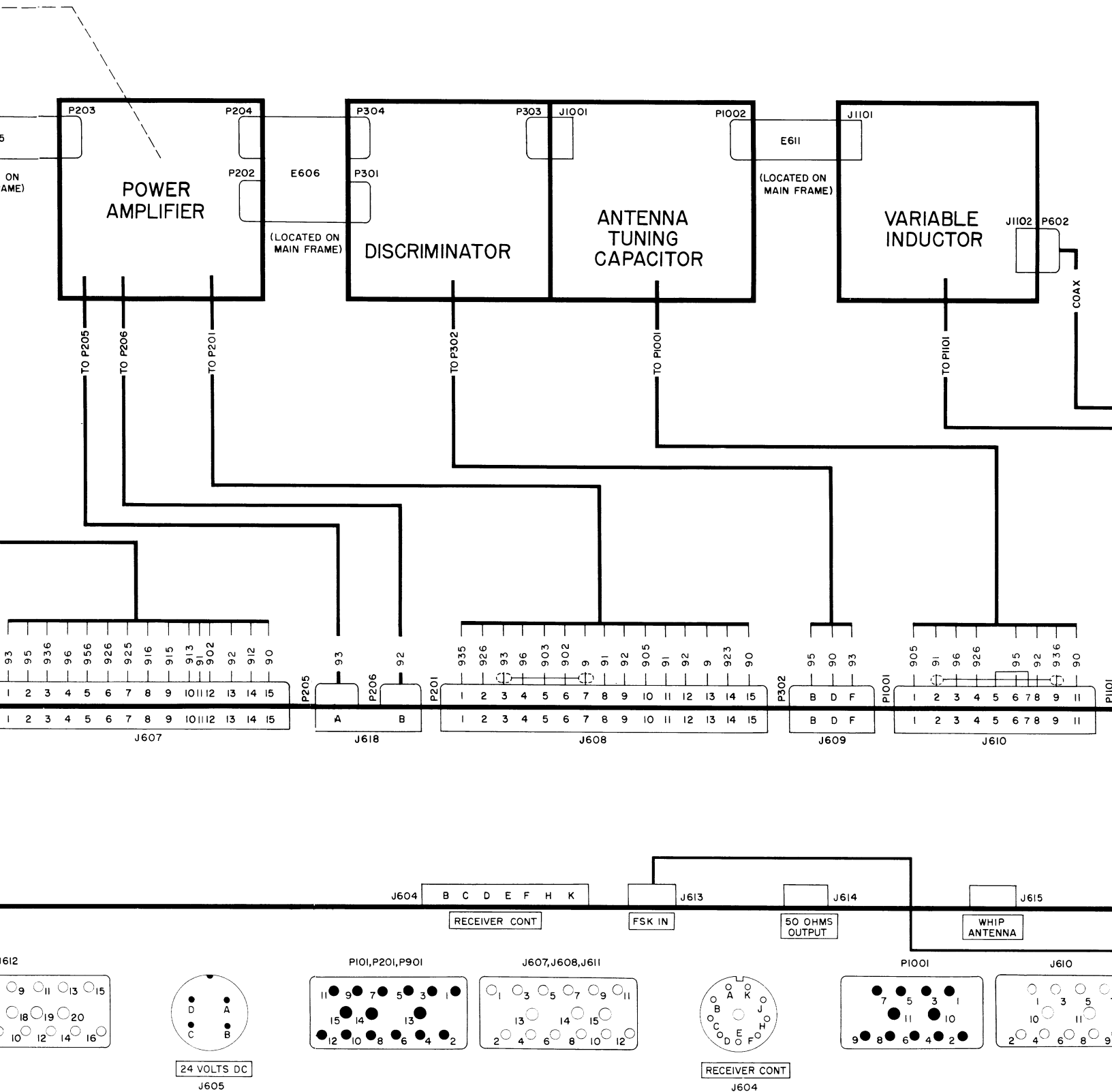
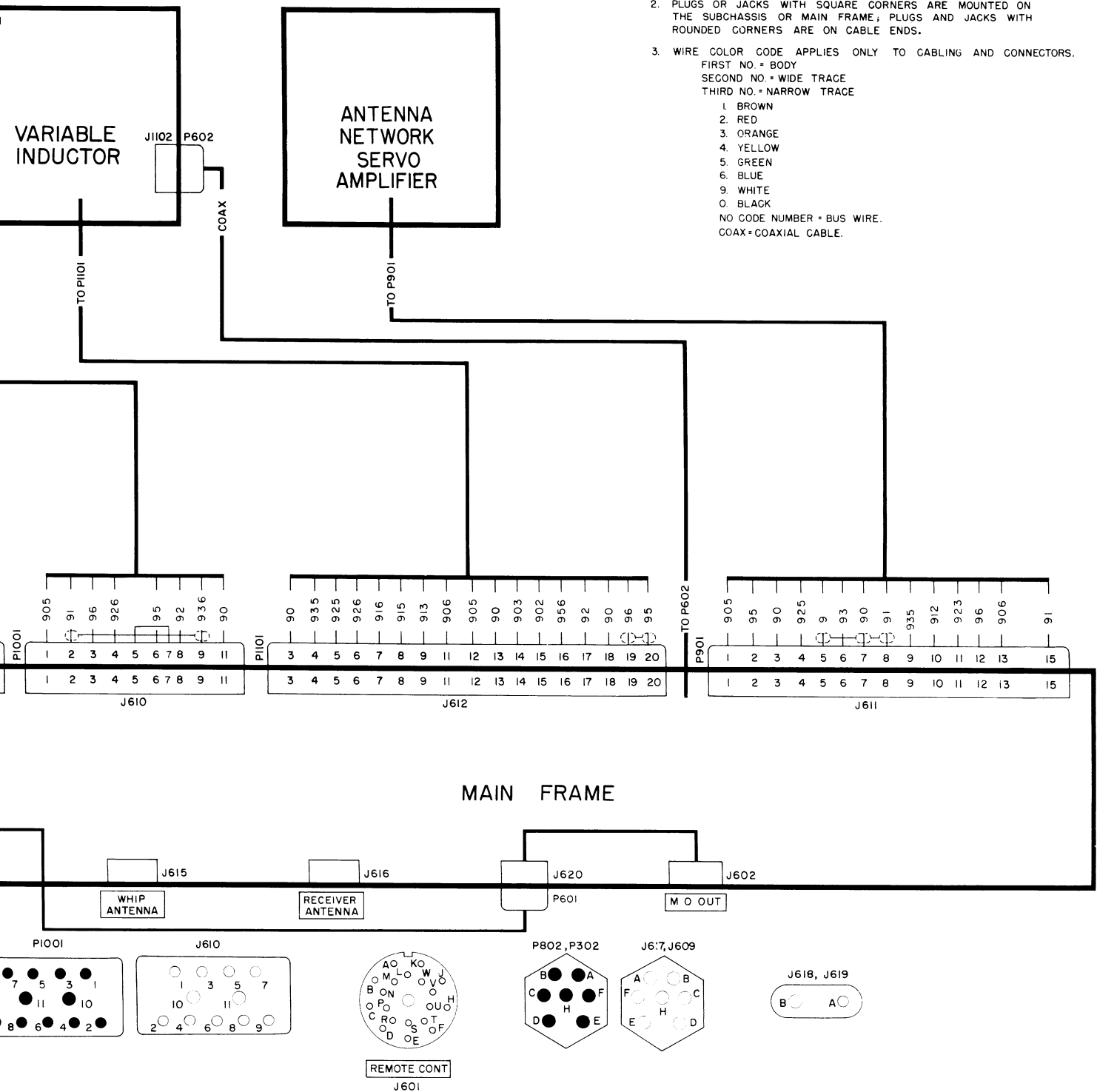

Figure 138. Subchassis interconnection cabling diagram

NOTES:

1. FOR FSK OPERATION P601 CONNECTS TO J101; P801 TO J620.
2. PLUGS OR JACKS WITH SQUARE CORNERS ARE MOUNTED ON THE SUBCHASSIS OR MAIN FRAME; PLUGS AND JACKS WITH ROUNDED CORNERS ARE ON CABLE ENDS.
3. WIRE COLOR CODE APPLIES ONLY TO CABLING AND CONNECTORS.
 FIRST NO. = BODY
 SECOND NO. = WIDE TRACE
 THIRD NO. = NARROW TRACE
 1. BROWN
 2. RED
 3. ORANGE
 4. YELLOW
 5. GREEN
 6. BLUE
 9. WHITE
 0. BLACK
 NO CODE NUMBER = BUS WIRE.
 COAX = COAXIAL CABLE.



TM806-136

390412 O - 56 (In pocket) No. 22

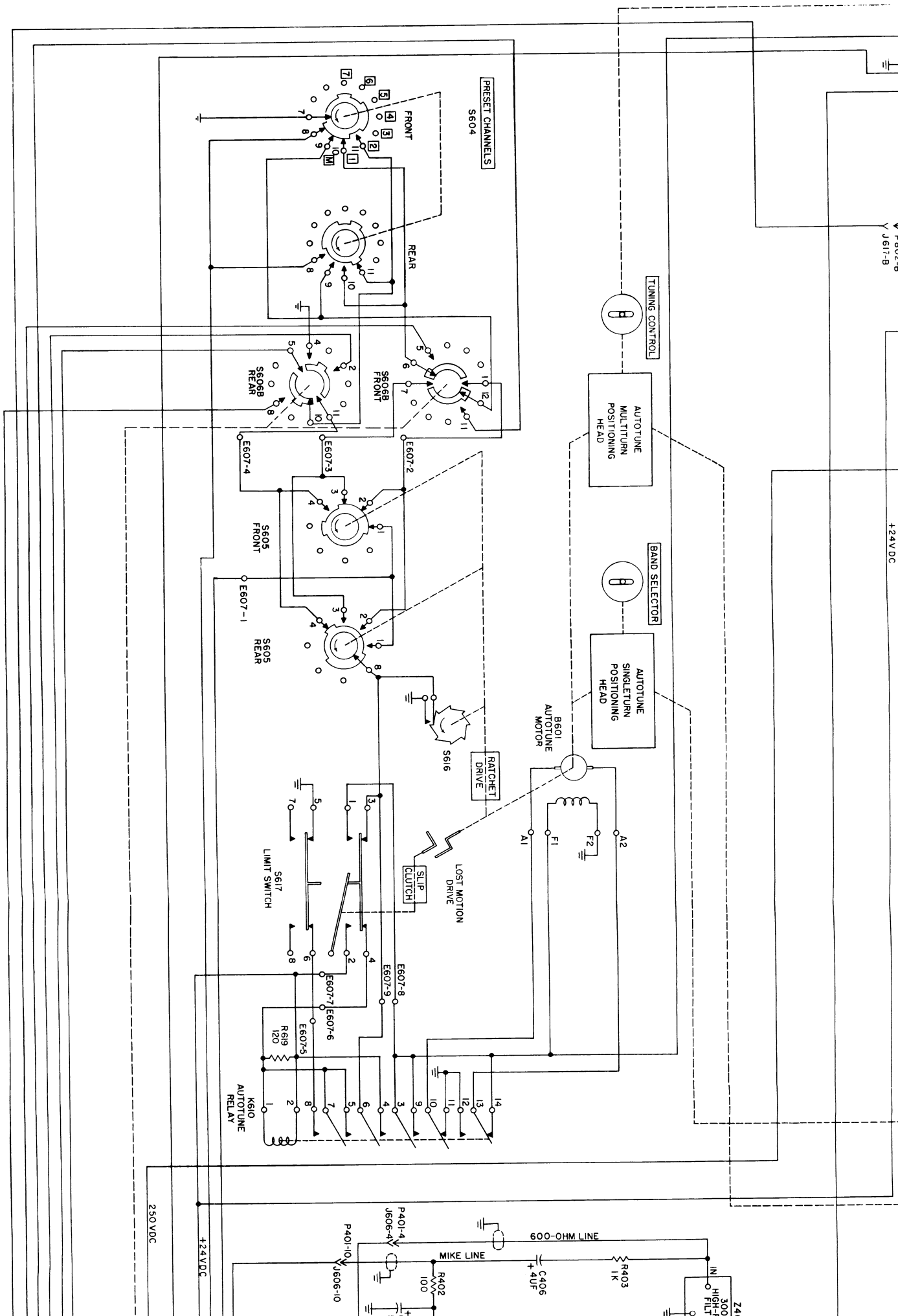

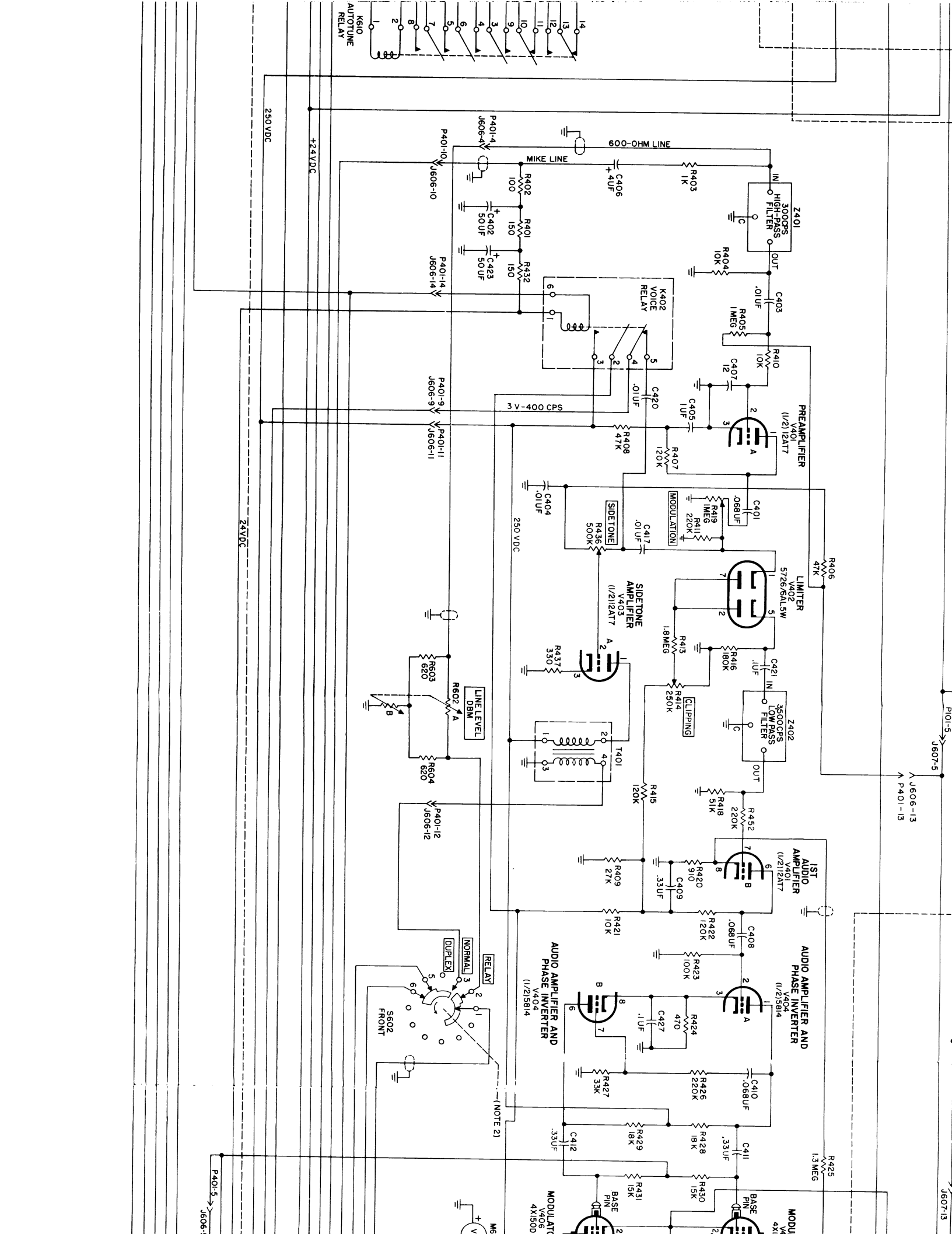

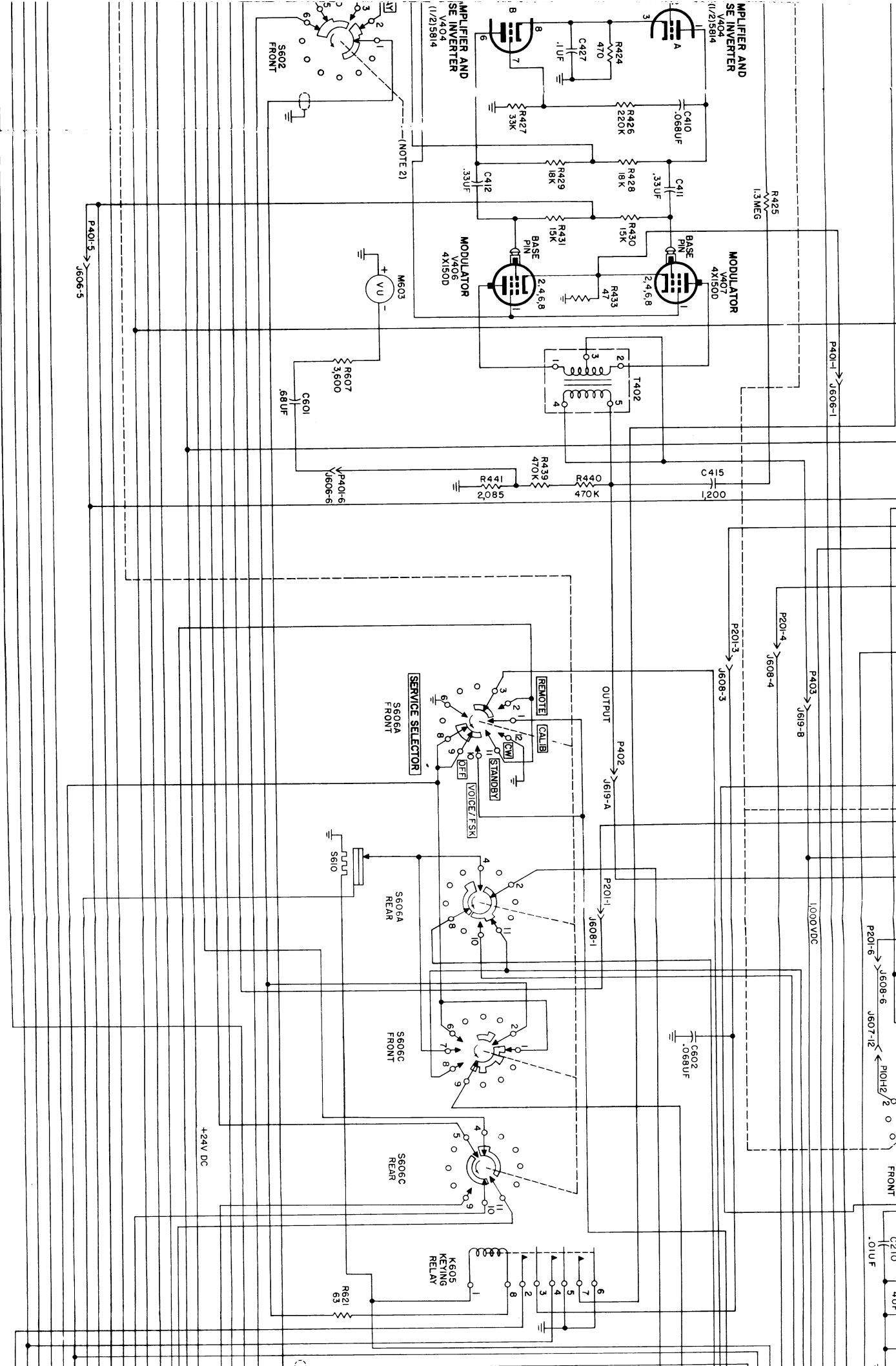
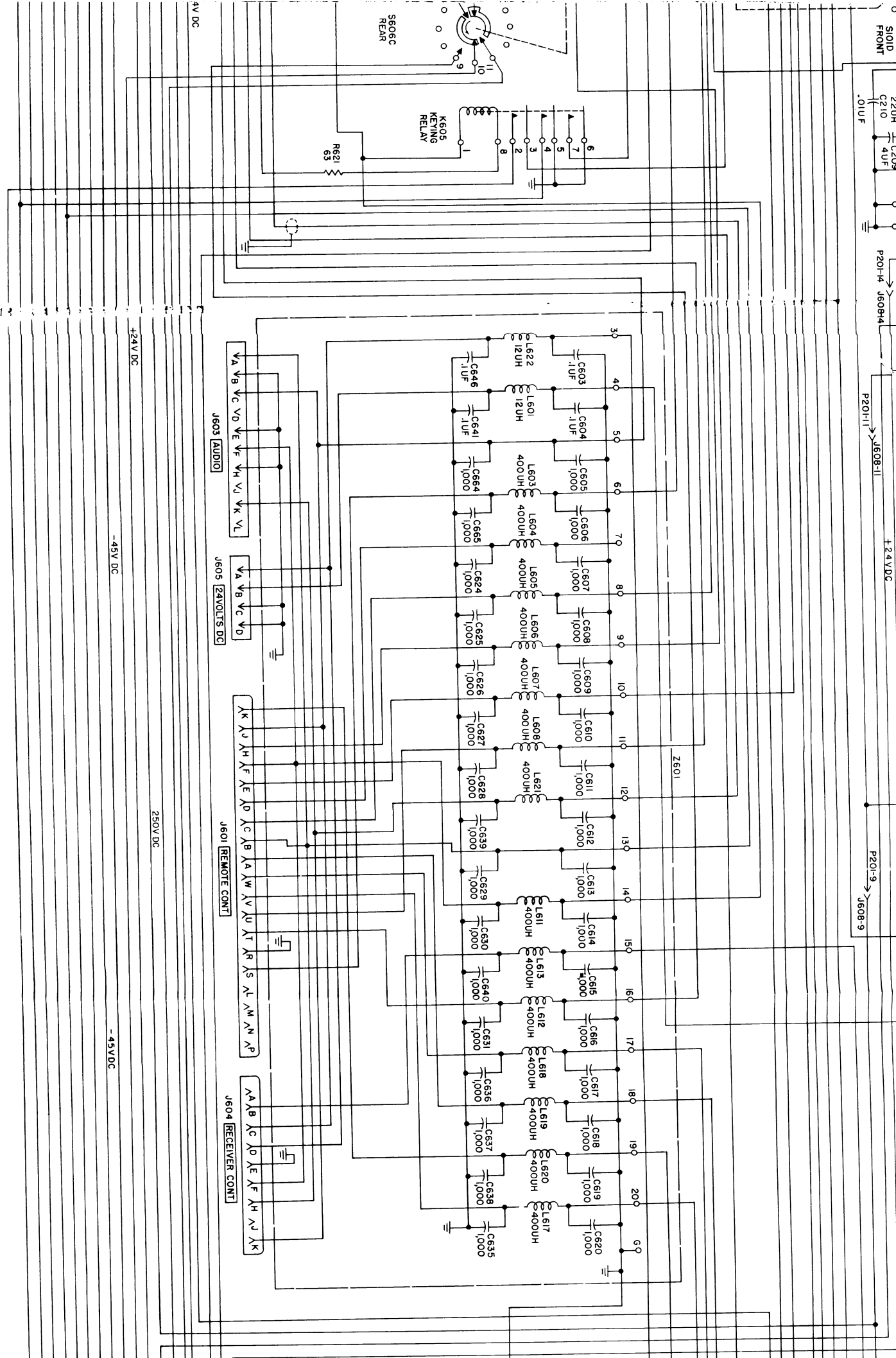
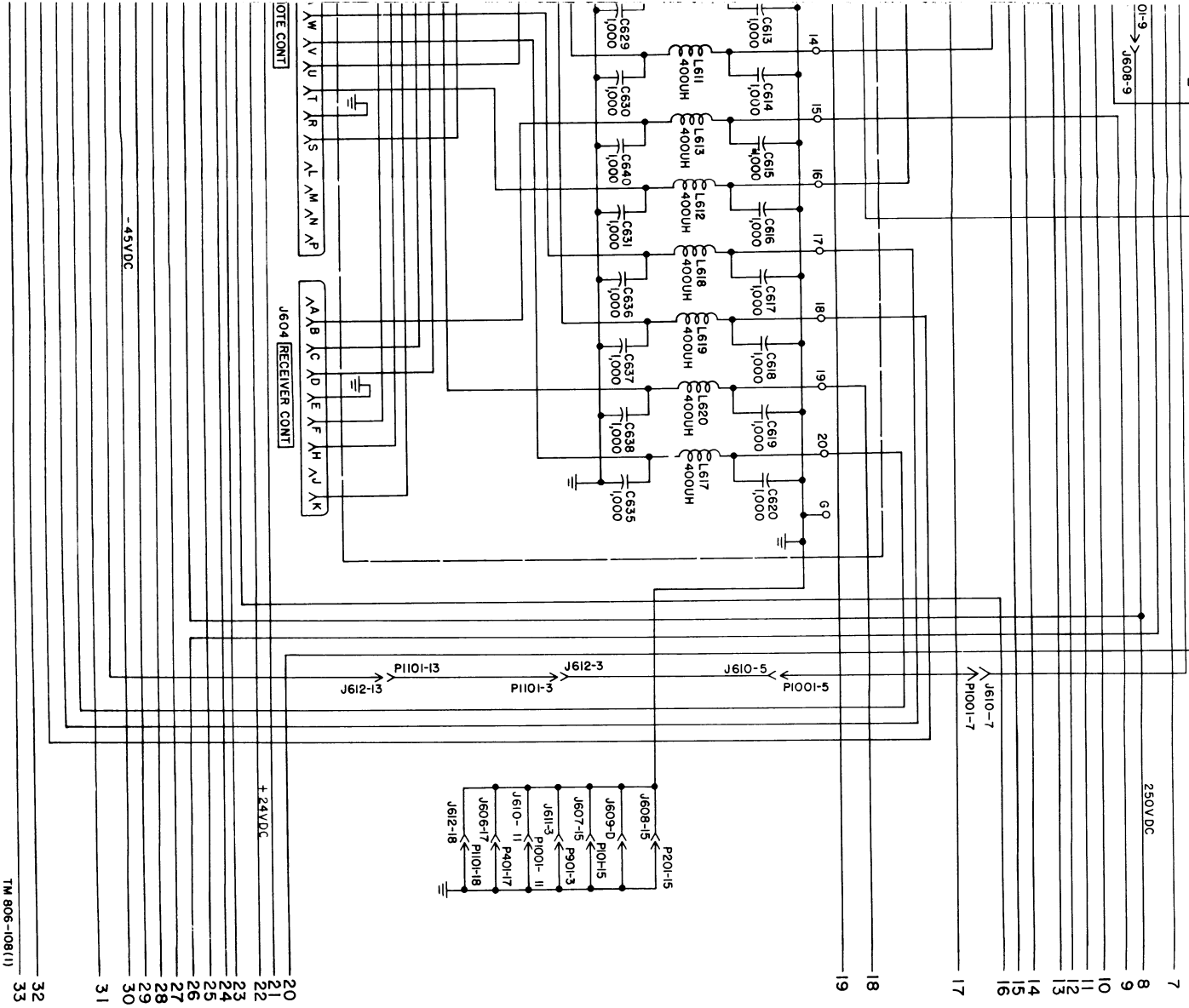

Figure 139. Radio Transmitter T-195/GRC-19, schematic diagram.





TM 806-108(1)

32
33

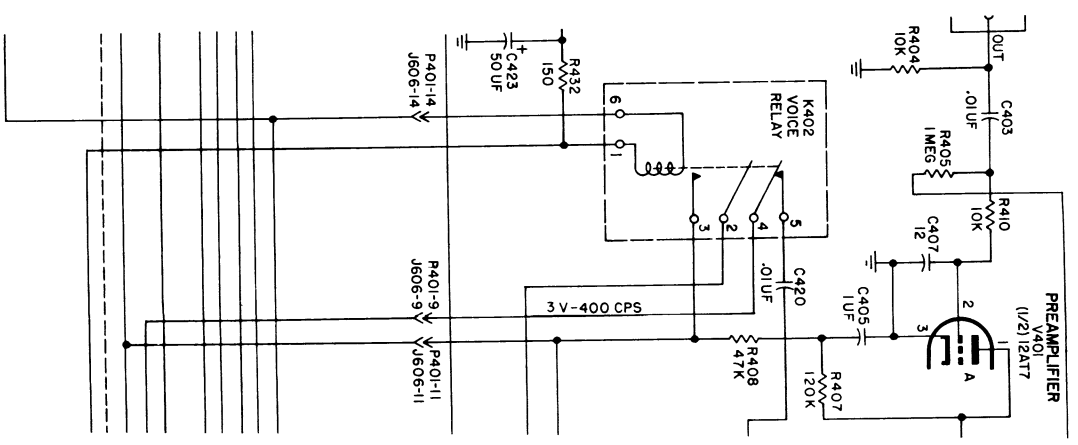

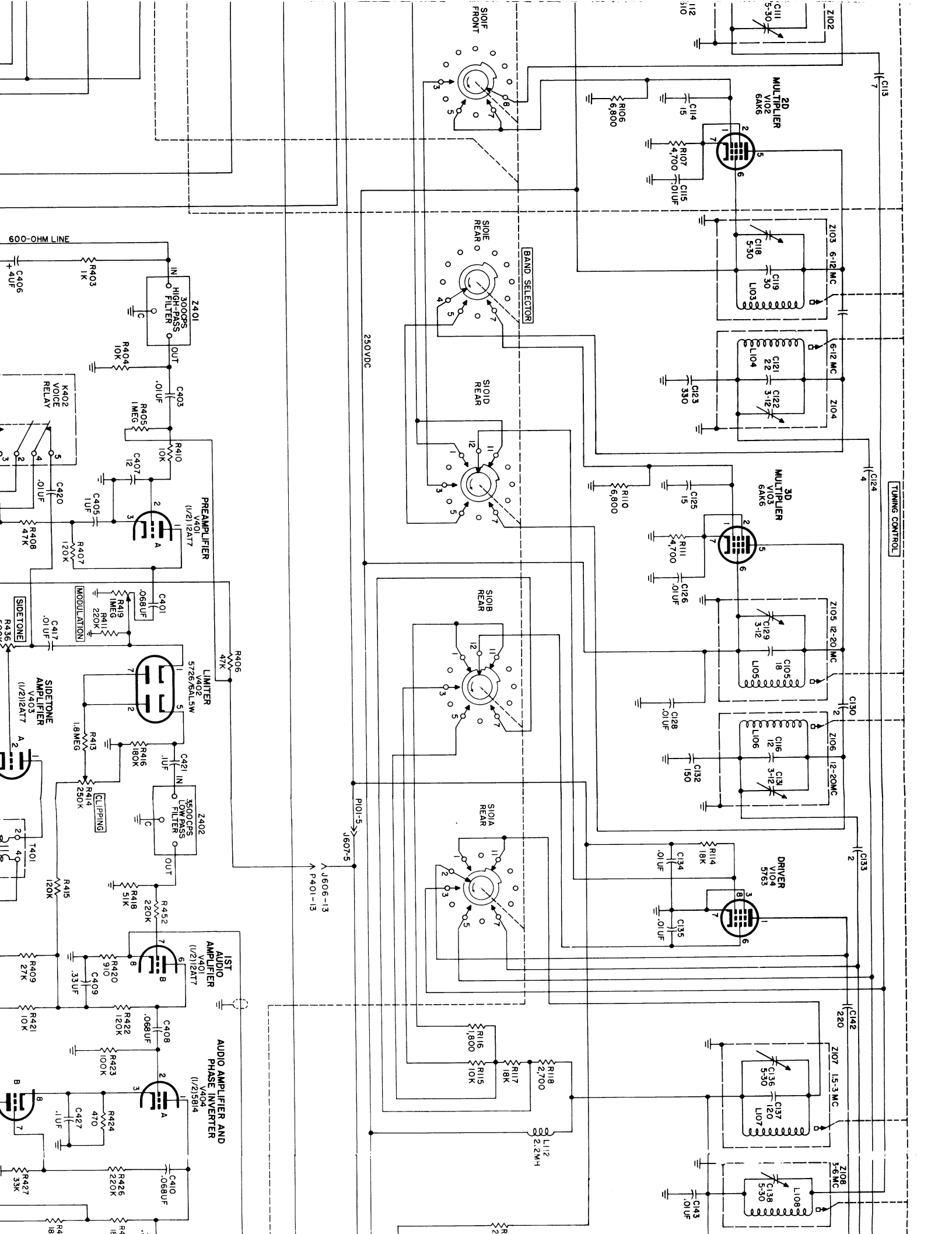

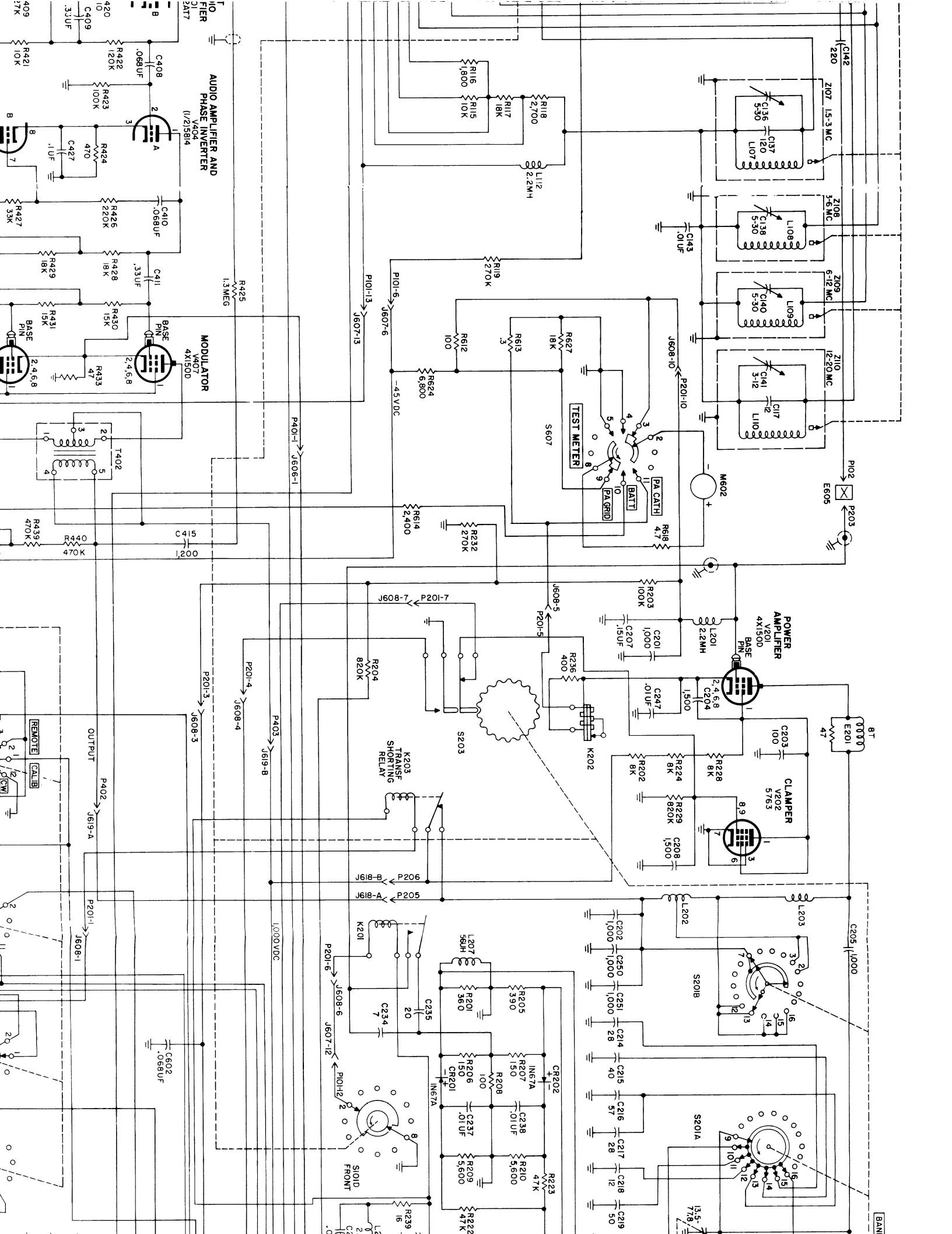

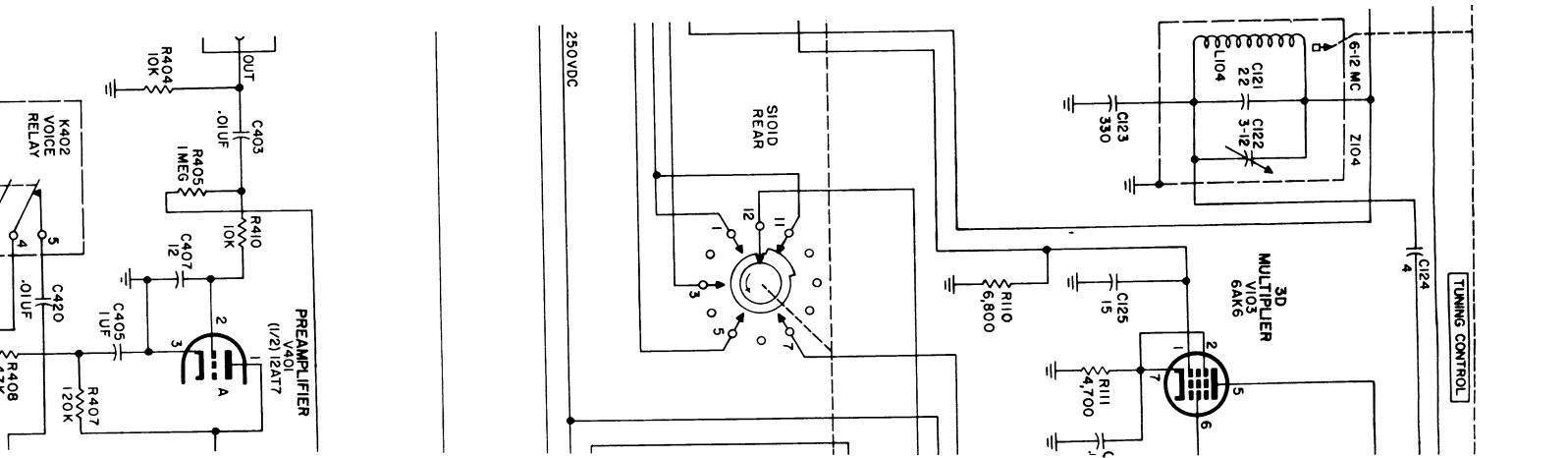
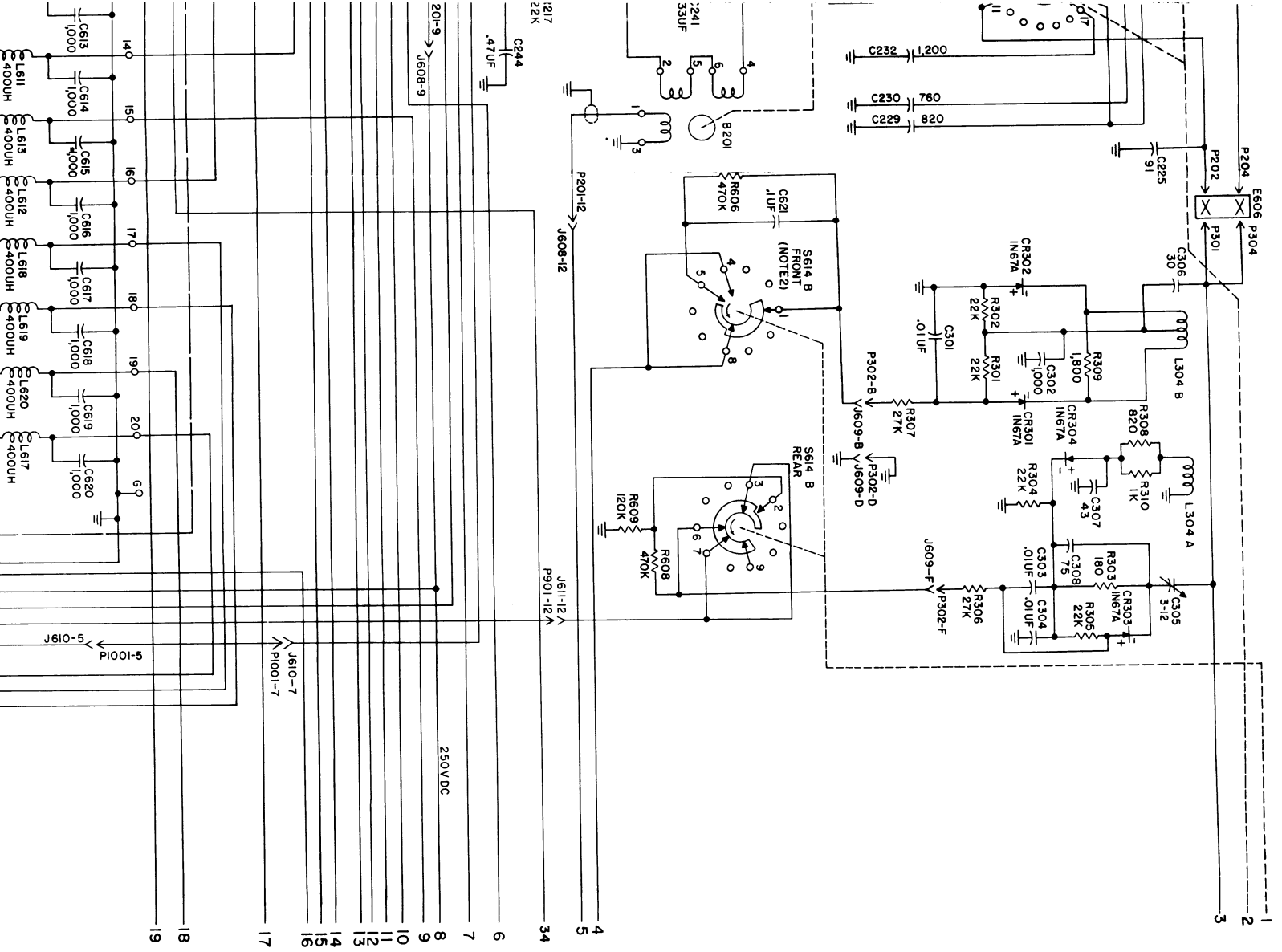

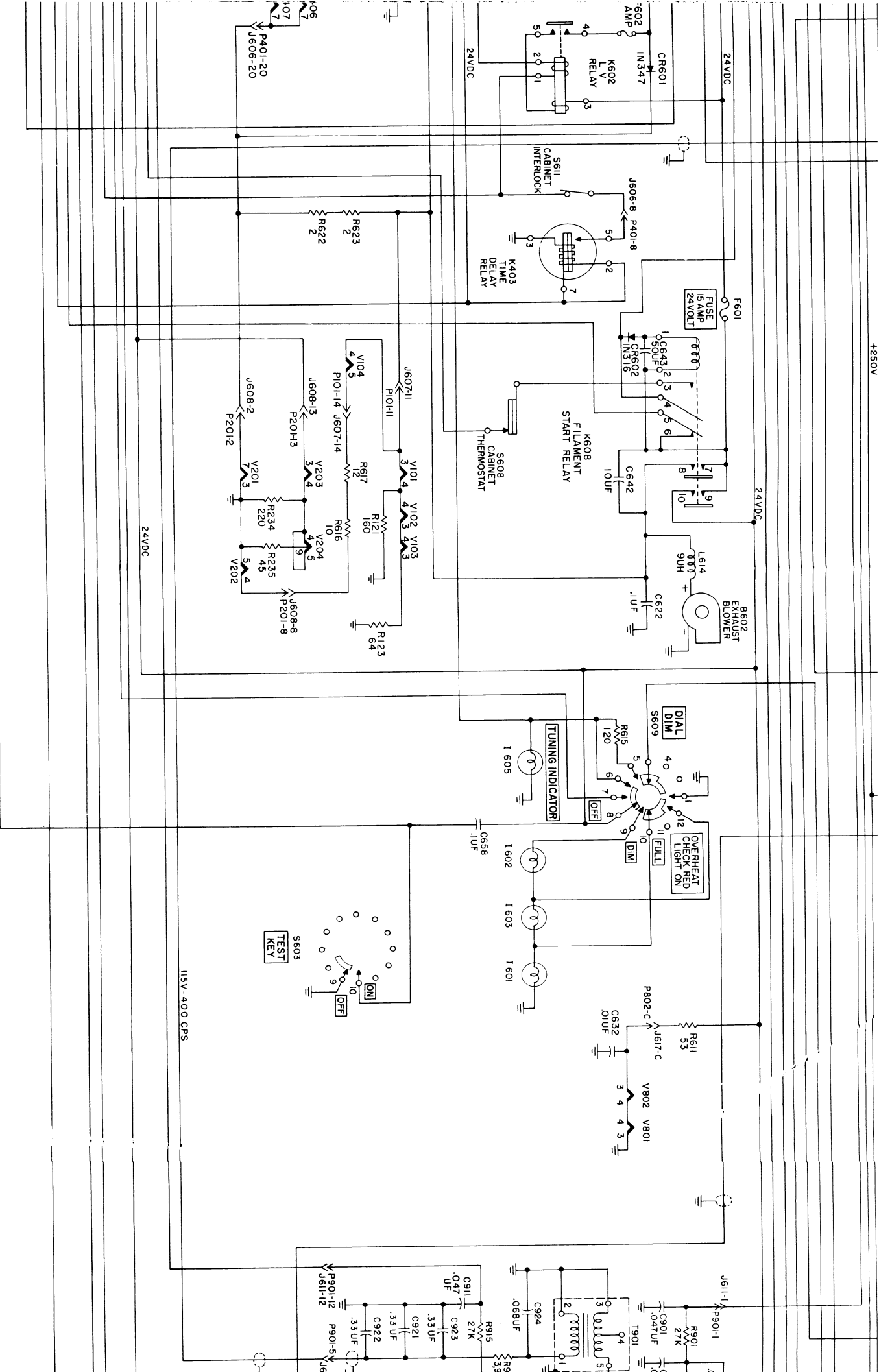
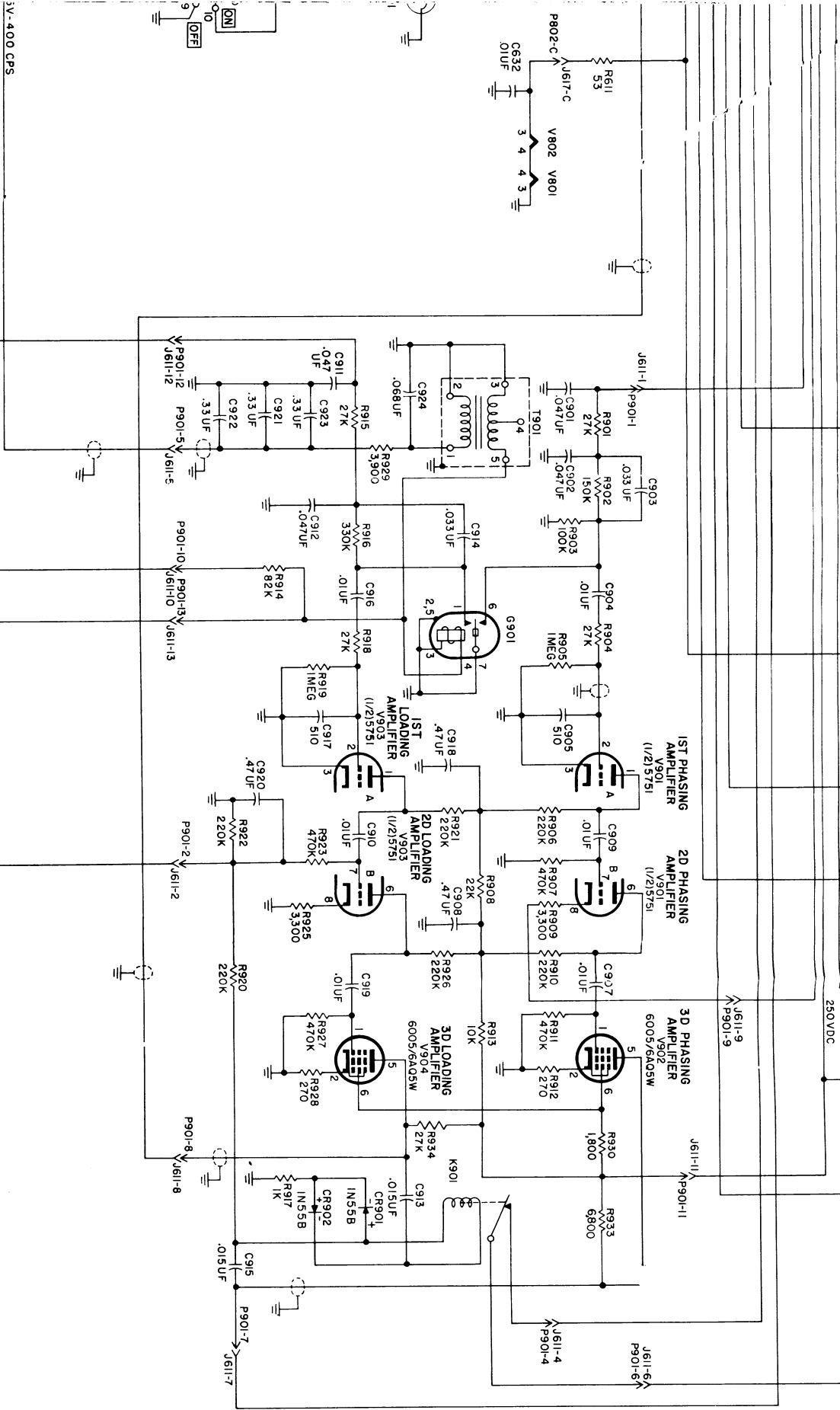
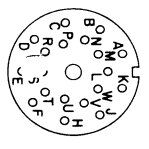
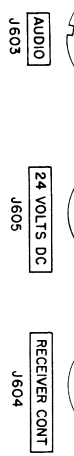
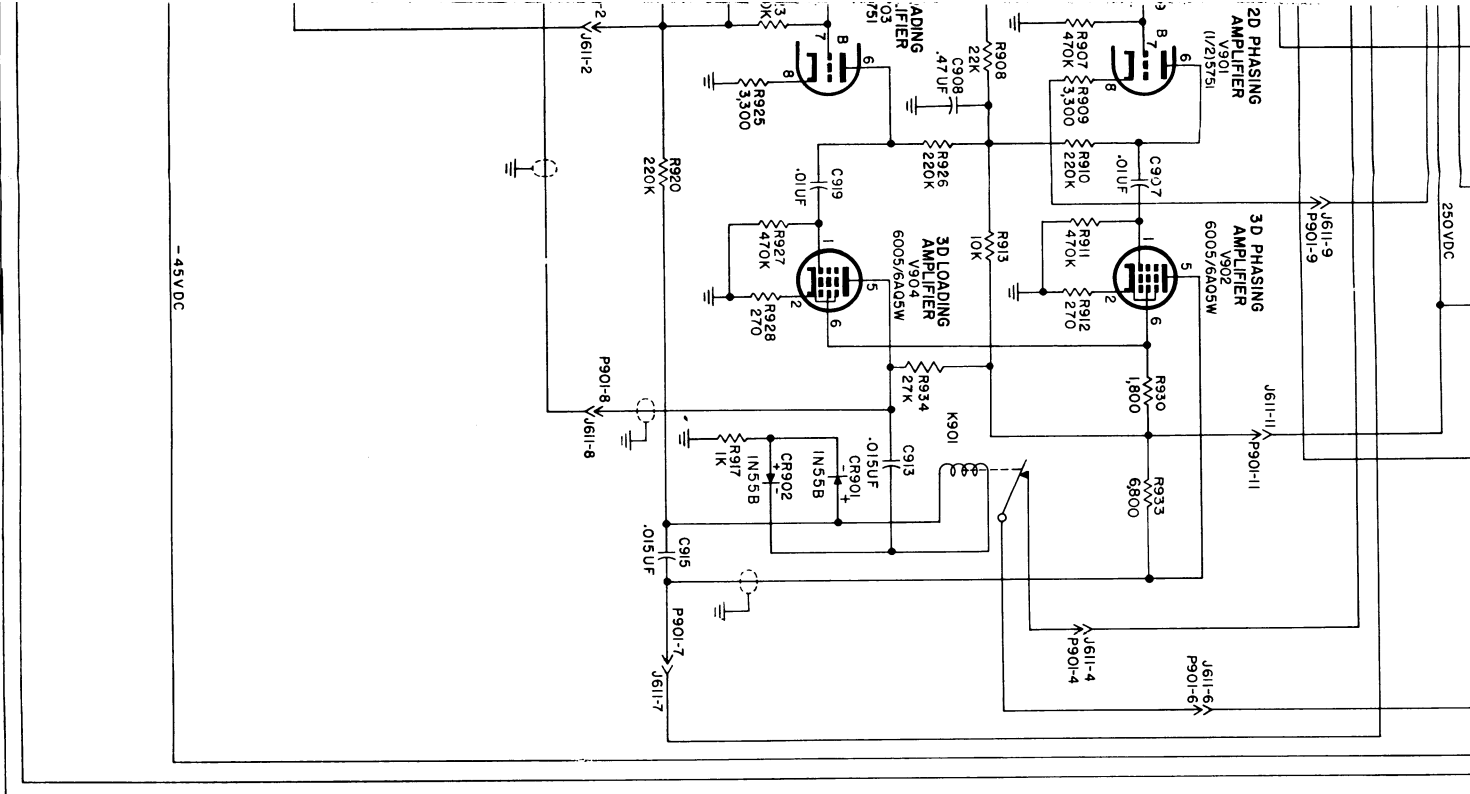

Figure 139. Radio Transmitter T-195/GRC-19, schematic diagram—Continued.



-45VDC



THE FOLLOWING LEGEND IDENTIFIES RECEPTACLE CONTACTS.

RECEPTACLE	CONTACT	FUNCTION	RECEPTACLE	CONTACT	FUNCTION
J601	K	TUNING INDICATOR	J603	A	600-OHM LINE
	J	MICROPHONE		B	GROUND
	H	L-V DYNAMOTOR START		C	MICROPHONE
	F	KEY OR MICROPHONE SWITCH		E	GROUND
	E	FSK RELAY CONTROL		F	KEY OR MICROPHONE SWITCH
	D	SERVICE SELECTOR SW CONTROL +24V		H	GROUND
	C	SERVICE SELECTOR SW CONTROL GND		K	CARRIER CONTROL
	B	600-OHM LINE		B	BREAK-IN CIRCUIT
	A	AUTOTUNE CONTROL		C	MICROPHONE
	W	AUTOTUNE CONTROL		D	+24V
	V	AUTOTUNE CONTROL		E	GROUND
	U	VOICE RELAY		F	KEY OR MICROPHONE
	T	AUTOTUNE CONTROL		H	600-OHM LINE
R	GROUND	K	CARRIER CONTROL		
S	FILAMENT START RELAY	A	+24V		
		B	+24V		
		C	GROUND		
		D	GROUND		

NOTES:

- UNLESS OTHERWISE SHOWN: RESISTORS ARE IN OHMS, CAPACITORS ARE IN UUF.
- SEPARATED FRONT AND REAR SECTIONS ARE SEPARATED FOR SCHEMATIC PURPOSES.
- ALL SWITCHES ARE VIEWED FROM THE REAR OF THE EQUIPMENT SECTIONS DESIGNATED. A ARE CLOSEST TO THE FRONT PANEL.
- ALL SWITCHES ARE SHOWN IN THEIR OFF OR COUNTERCLOCKWISE POSITION, AS VIEWED FROM THE FRONT PANEL, OR POSITIONED FOR 1.5 TO 1.7 MC RANGE

ALL SWITCHES AND RELAYS ARE SHOWN IN THEIR NORMAL POSITION WITH POWER REMOVED.

6. THE PHYSICAL LOCATION OF COMPONENTS CAN BE DETERMINED FROM THE FOLLOWING SYMBOL GROUPS:

- SUBCHASSIS GROUP
- EXCITER 100
- POWER AMPLIFIER 200
- DISCRIMINATOR 300
- MODULATOR 400
- MAIN FRAME AND FRONT PANEL 500
- MASTER OSCILLATOR 600
- ANTENNA NETWORK SERVO 800
- AMPLIFIER 900
- ANTENNA TUNING CAPACITOR 1000
- VARIABLE INDUCTOR 1100

-45VDC

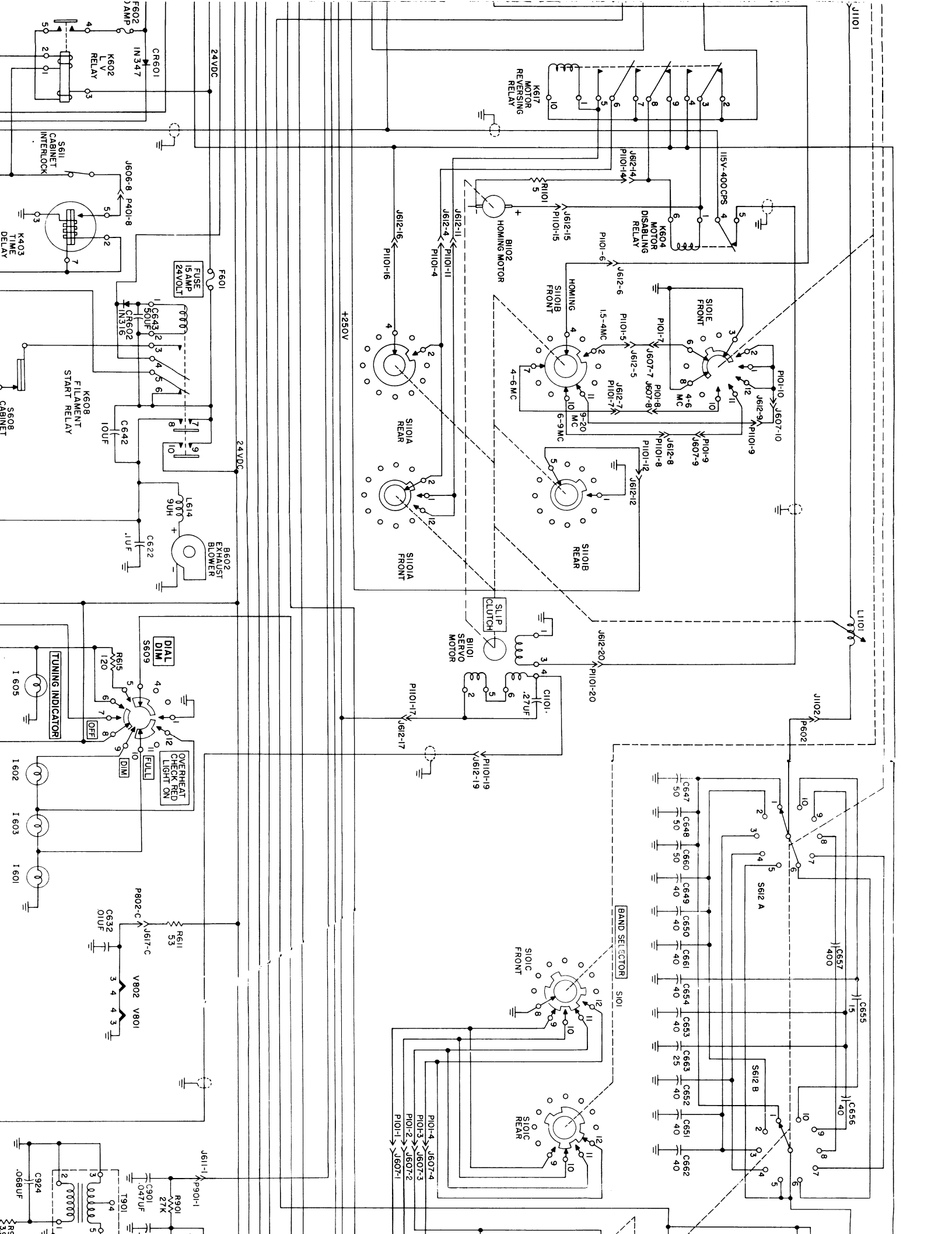

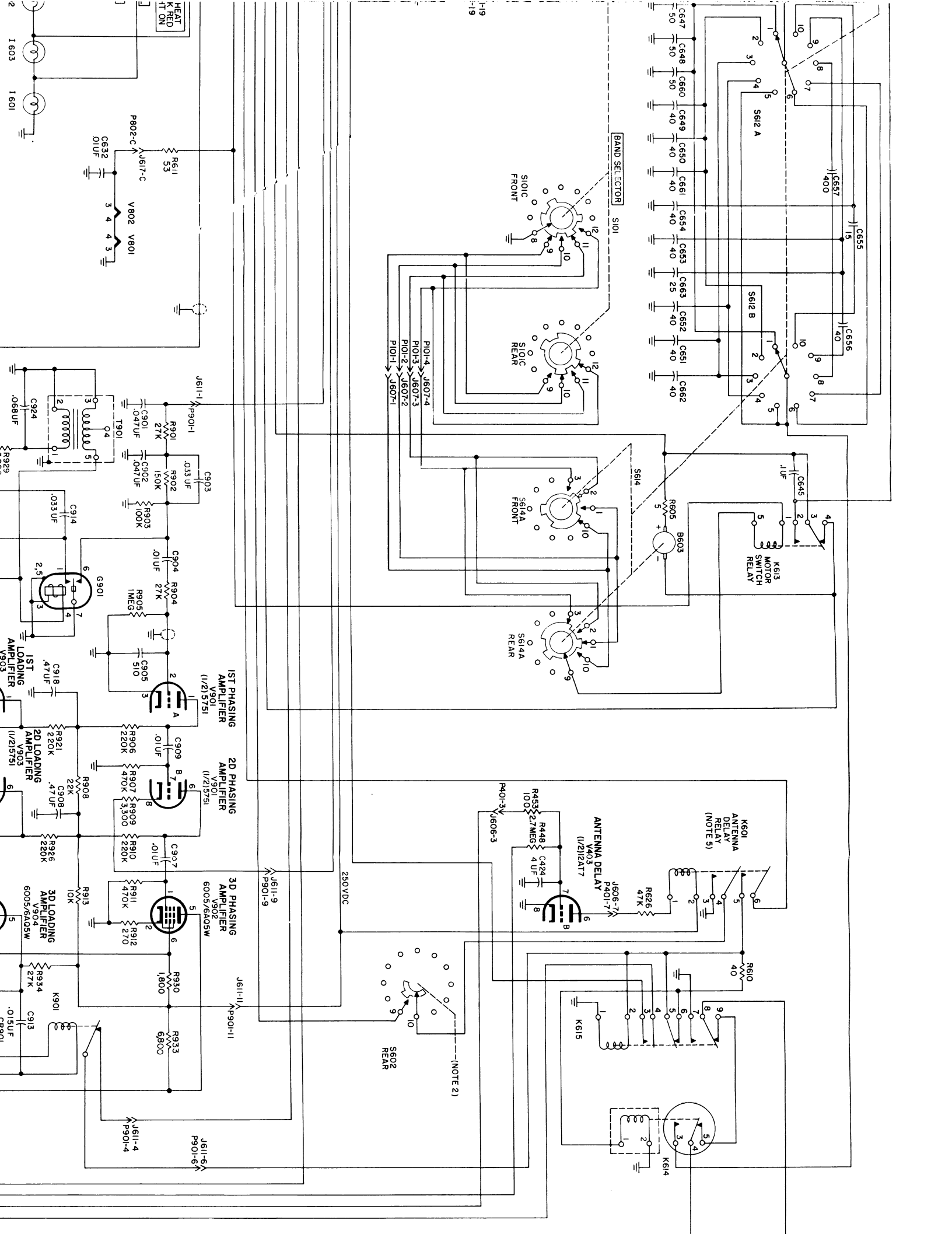

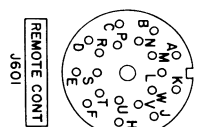
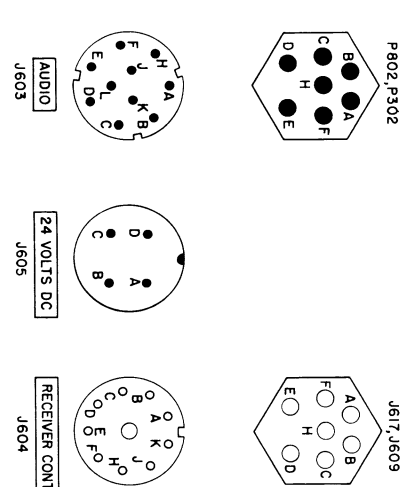
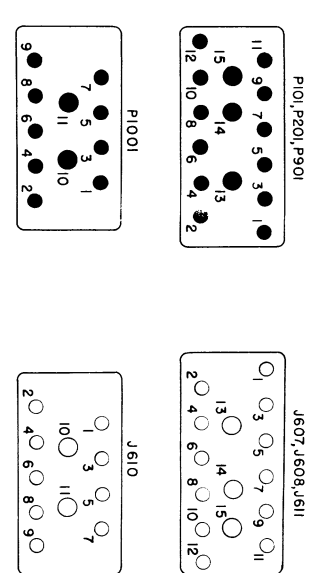
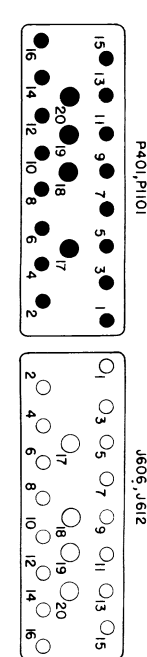
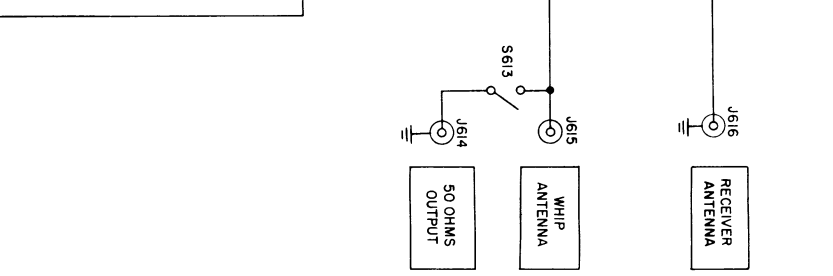
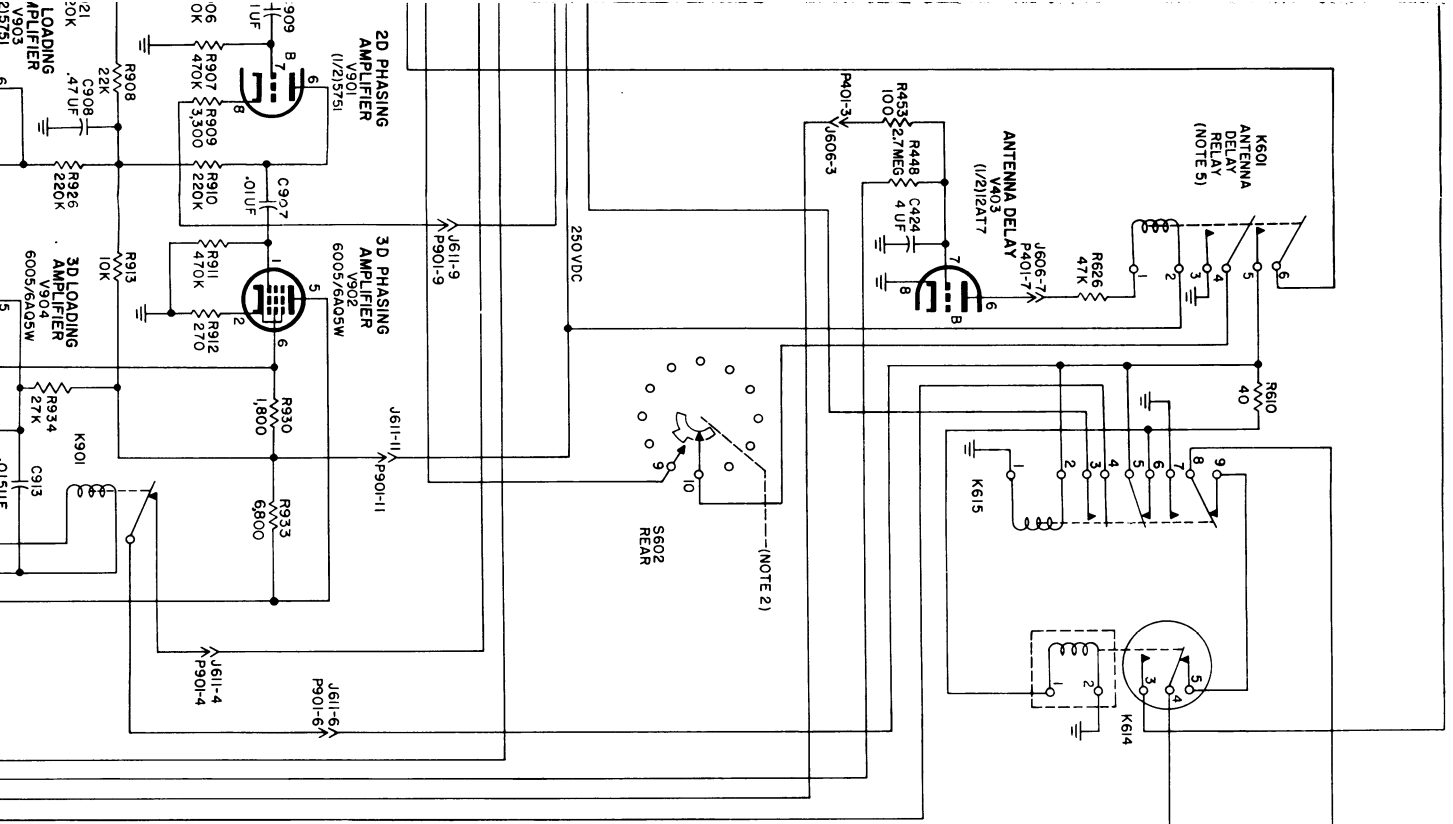

THE FOLLOWING LEGEND IDENTIFIES RECEPTACLE CONTACTS.

RECEPTACLE CONTACT	FUNCTION	RECEPTACLE CONTACT	FUNCTION
J601	TUNING INDICATOR MICROPHONE	J603	600-OHM LINE
K	L-V DYNAMOTOR START	A	GROUND
J	KEY OR MICROPHONE SWITCH	B	GROUND
H	FSK RELAY CONTROL	C	GROUND
F	SERVICE SELECTOR SW CONTROL +24V	E	KEY OR MICROPHONE SWITCH
D	SERVICE SELECTOR SW CONTROL GND	F	GROUND
C	600-OHM LINE	H	CARRIER CONTROL
B	600-OHM LINE	K	BREAK-IN CIRCUIT
		J604	MICROPHONE