

TECHNICAL MANUAL

DS, GS, AND DEPOT MAINTENANCE MANUAL

**RADIO TRANSMITTER**

**T-195/GRC-19, T-195A/GRC-19  
AND T-195B/GRC-19**

## **WARNING**

Be careful when working on +250-volt plate circuits and on the 115-volt motor circuits. Serious injury or death may result from contact with these circuits.

## **DON'T TAKE CHANCES!**

DANGEROUS VOLTAGES EXIST IN THE FOLLOWING UNITS OF RADIO TRANSMITTER T-195/GRC-19, T-195A/GRC-19 AND T-195B/GRC-19:

Modulator	1,000 volts
Power Amplifier	1,000 volts



TECHNICAL MANUAL }  
 No. 11-5820-335-35 }

HEADQUARTERS  
 DEPARTMENT OF THE ARMY  
 WASHINGTON, D. C., 17 November 1970

**DS, GS, and Depot Maintenance Manual**

**RADIO TRANSMITTER T-195/GRC-19,  
 T-195A/GRC-19 AND T-195B/GRC-19**

	Paragraph	Page
<b>CHAPTER 1. FUNCTIONING</b>		
Section I. System Functioning -----	1-1-1-3	1-1, 1-2
II. General Functioning of Transmitter -----	1-4	1-4
III. Master Oscillator Stages -----	1-5-1-8	1-7, 1-8
IV. Exciter -----	1-9-1-14	1-9-1-13
V. Power-Amplifier Stages -----	1-15-1-18	1-16-1-21
VI. Modulator -----	1-19-1-26	1-28-1-33
VII. Antenna-Tuning System -----	1-27-1-32	1-35-1-50
VIII. Antenna Switching and Keying Circuits -----	1-33-1-35	1-57
IX. Autotune System -----	1-36-1-40	1-62-1-73
X. Power Circuits and Servo Motors -----	1-41-1-54	1-75-1-97
<b>CHAPTER 2. TROUBLESHOOTING</b>		
Section I. General Troubleshooting Information -----	2-1-2-4	2-1-2-3
II. Interunit Troubleshooting -----	2-5	2-4
III. Unit Troubleshooting -----	2-6-2-9	2-8-2-18
IV. Additional Troubleshooting Data -----	2-10-2-11	2-93, 2-94
<b>CHAPTER 3. REPAIRS AND ALINEMENT</b>		
Section I. Repairs -----	3-1-3-4	3-1-3-23
II. Alinement -----	3-5-3-16	3-28-3-35
<b>CHAPTER 4. GENERAL SUPPORT MAINTENANCE -----</b>		4-1
5. GENERAL SUPPORT TESTING PROCEDURES -----		5-1
6. DEPOT OVERHAUL STANDARDS -----		6-1
7. AUXILIARY EQUIPMENT		
Section I. Transmitter Control C-822/GRC-19 -----	7-1-7-7	7-1-7-4
II. Radio Set Control Group OA-1754/GRC -----	7-8-7-13	7-6, 7-7
<b>APPENDIX A. REFERENCES -----</b>		A-1
B. GLOSSARY OF TERMS -----		B-1
<b>INDEX -----</b>		I-1

## LIST OF ILLUSTRATIONS

<i>Fig. No.</i>	<i>IN</i>	<i>Caption</i>
1-1	TM 806-C8-1	Auxiliary dust filter assembly with filter removed.
1-2	TM 5820-335-10-5	Auxiliary dust filter assembly installed.
1-3	TM 806-2	Radio Set AN/GRC-19, simplified system block diagram.
1-4	TM 806-3	Frequency-shift, single channel radioteletype system, simplified block diagram.
1-5	TM 5820-335-35-2	Radio Transmitter T-195/GRC-19 composite block diagram.
1-6	TM 806-22	Master oscillator, block diagram.
1-7	TM 5820-335-35-3	Master oscillator, functional diagram.
1-8	TM 5820-335-35-37	Thermostat S801, simplified schematic.
1-9	TM 806-24	Exciter, block diagram.
1-10	TM 806-25	First multiplier stage, functional diagram.
1-11	TM 806-26	Second multiplier stage, functional diagram.
1-12	TM 806-27	Third multiplier stage, functional diagram.
1-13	TM 806-28	Driver stage, functional diagram.
1-14	TM 806-29	Neutralization circuit, functional diagram.
1-15	TM 806-30	Power-amplifier, block diagram.
1-16	TM 806-31	Power-amplifier and clamper stages, functional diagram.
1-17	TM 806-32	Power-amplifier plate circuit, functional diagram.
1-18	TM 806-33	Power-amplifier discriminator circuits, functional diagram.
1-19	TM 806-126	Power-amplifier discriminator voltage vectors.
1-20	TM 806-34	Power-amplifier chopper and servo amplifier stages, functional diagram.
1-21	TM 5820-335-35-4	Modulator, block diagram.
1-22	TM 5820-335-35-5	Preamplifier stage, functional diagram.
1-23	TM 806-37	Limiter stage, functional diagram.
1-24	TM 806-38	First audio amplifier, functional diagram.
1-25	TM 806-39	Second audio amplifier and phase inverter, functional diagram.
1-26	TM 806-40	Modulator stage, functional diagram.
1-27	TM 5820-335-35-6	Sidetone amplifier stage, functional diagram.
1-28	TM 806-175	Antenna tuning system, simplified schematic.
1-29	TM 806-42	Antenna tuning system, block diagram.
1-30	TM 5820-335-35-7	Homing cycle flow chart.
1-31	TM 806-43	Homing circuits, functional diagram.
1-32	TM 806-44	Phasing discriminator, functional diagram.
1-33	TM 806-150	Phasing discriminator voltage relationships.
1-34	TM 806-45	Loading discriminator, functional diagram.
1-35	TM 5820-334-35-8	Antenna network servo amplifier input circuits, functional diagram.
1-36	TM 806-C5-8	Antenna network servo amplifier transistorized chopper, schematic diagram.
1-37	TM 5820-335-35-9	Antenna network servo amplifier, amplifying circuits, functional diagram.
1-38	TM 806-48	Antenna network servo amplifier, output circuits, functional diagram.
1-39*	TM 806-49	Output capacitor, functional diagram.
1-40	TM 806-50	Antenna switching and keying, flow chart.
1-41*	TM 5820-335-35-10	Antenna switching and keying circuits, functional diagram.
1-42	TM 806-C10-1	Hermetically sealed receiver antenna relay K615 (used in T-195B/GRC-19 on order No. 4096-PP-60) schematic diagram.
1-43	TM 5820-335-35-12	Autotune circuits, flow chart.
1-44	TM 5820-335-35-11	Autotune control circuits, functional diagram.
1-45	TM 806-C5-10	Hermetically sealed autotune relay K610, schematic diagram.

## LIST OF ILLUSTRATIONS—Continued

<i>Fig. No.</i>	<i>IN</i>	<i>Caption</i>
1-46	TM 806-C10-2	Hermetically sealed autotune relay K610 (used in T-195B/GRC-19 on Order No. 4096-PP-60), schematic diagram.
1-47	TM 806-53	Single turn positioning, simplified drawing.
1-48	TM 806-54	Multiturn positioning head, representative drawing.
1-49	TM 806-122	Complete tuning cycle, flow chart.
1-50	TM 5820-335-35-13	Power circuits flow chart.
1-51	TM 5820-335-35-14	24-volt distribution, functional diagram.
1-52	TM 806-C10-3	Hermetically sealed autotune relay K608 (used in T-195B/GRC-19 on Order No. 4096-PP-60), schematic diagram.
1-53	TM 806-C10-12	Hermetically sealed LV Relay K602 (used in T-195B/GRC-19 on Order No. 4096-PP-60), schematic diagram.
1-54	TM 806-58	115-volt, 400-cps distribution, functional diagram.
√1-55	TM 5820-335-35-15	+250-volt distribution, functional diagram.
1-56	TM 806-C5-11	Transistorized power supply, simplified schematic diagram.
1-57	TM 806-C5-13	High-voltage power supply A1200, schematic diagram.
1-58	TM 806-C6-2	High-voltage power supply.
1-59	TM 806-9	Servo mechanism operation.
1-60	TM 5820-335-35-16	Exhaust blower B602, transistor-type schematic diagram.
1-61	TM 806-C9-2	Pa blower B202, transistor-type, schematic diagram.
1-62	TM 5820-335-35-17	Transistor-type low-voltage power supply, schematic diagram.
1-63	TM 5820-335-35-18	Transistor-type high-voltage power supply, complete schematic diagram.
1-64	TM 806-C10-4	High-voltage power supply PS602, schematic diagram.
1-65	TM 806-C10-5	Low-voltage power supply PS601, schematic diagram.
2-1	TM 806-115	Fabrication of test cables.
2-2	TM 806-104	Dummy antenna.
2-3	TM 5820-335-35-19	Master-oscillator subchassis, top view.
2-4	TM 5820-335-35-20	Master-oscillator subchassis, bottom view.
2-5	TM 806-113	Master-oscillator subchassis, bottom view, sealed circuit, cover removed.
2-6	TM 806-114	Master-oscillator subchassis, top view sealed circuit, cover removed.
2-7	TM 5820-335-35-21	Exciter subchassis, top view.
2-8	TM 806-79	Exciter subchassis, bottom view.
2-9	TM 806-80	Exciter subchassis, side view.
2-10	TM 5820-335-35-22	Exciter subchassis, front view.
2-11	TM 806-83	Power amplifier subchassis, top view.
2-12	TM 5820-335-35-23	Power amplifier subchassis, bottom view.
2-13	TM 806-85	Power amplifier subchassis, side view.
2-14	TM 806-81	Power amplifier subchassis, front view.
2-15	TM 806-82	Power amplifier subchassis, rear view.
2-16	TM 806-84	Power amplifier discriminator, bottom view.
2-17	TM 806-86	Power amplifier discriminator, terminal board.
2-18	TM 806-64	Discriminator subchassis, right view.
2-19	TM 806-65	Discriminator subchassis, left view.
2-20	TM 806-66	Discriminator subchassis, bottom view.
2-21	TM 806-68	Modulator subchassis, top view.
2-22	TM 806-69	Modulator subchassis with modulator tube subchassis removed.
2-23	TM 806-70	Modulator subchassis, bottom view.
2-24	TM 806-71	Modulator subchassis, terminal board removed.
2-25	TM 806-67	Modulator subchassis, rear view.
2-26	TM 5820-335-35-24	Antenna network servo amplifier, cover removed, top view.

## LIST OF ILLUSTRATIONS—Continued

<i>Fig. No.</i>	<i>IN</i>	<i>Caption</i>
2-27	TM 806-76	Antenna network servo amplifier, oblique side view.
2-28	TM 806-74	Antenna network servo amplifier, bottom view.
2-29	TM 806-75	Antenna network servo amplifier, terminal board removed.
2-30	TM 806-63	Antenna tuning capacitor subchassis, right view.
2-31	TM 806-62	Antenna tuning capacitor subchassis, left view.
2-32	TM 806-61	Variable inductor subchassis.
2-33	TM 806-C5-14	High-voltage power supply A1200, top view.
2-34	TM 806-C5-15	High-voltage power supply A1200, side view.
2-35	TM 806-C5-16	High-voltage power supply A1200, bottom view.
2-36	TM 806-C6-3	High-voltage power supply A1200 (MOD 1), side view.
2-37	TM 806-C6-4	High-voltage power supply A1200 (MOD 1), bottom view.
2-38	TM 806-C9-6	Transistor-type low-voltage power supply, location of frequency adjustment control.
2-39	TM 806-C9-5	Transistor-type low-voltage power supply, bottom view.
2-40	TM 806-C9-7	Transistor-type low-voltage power supply, interior view.
2-41	TM 5820-335-35-25	Transistor-type high-voltage power supply, top view, interior.
2-42	TM 5820-335-35-26	Transistor-type high-voltage power supply, side view, interior.
2-43	TM 806-C9-11	Transistor-type exhaust blower B602, side view.
2-44	TM 806-C9-12	Transistor-type pa blower B202, transistor power supply removed.
2-45	TM 806-C10-6	High-voltage power supply PS602, top view, cover removed.
2-46	TM 806-C10-7	High-voltage power supply PS601, bottom view, cover removed.
2-47	TM 806-C10-8	Low-voltage power supply PS601, top view, cover removed.
2-48	TM 806-C10-9	Low-voltage power supply PS601, bottom view, cover removed.
2-49	TM 806-99	Main frame, top view.
2-50	TM 806-100	Main frame, rear right view.
2-51	TM 5820-335-35-27	Main frame, regulator assembly removed.
2-52	TM 806-C2-1	Main frame MOD 5A and higher, bottom view of regulator assembly.
2-53	TM 5820-335-35-28	Main frame, bottom view.
2-54	TM 806-103	Main frame, oblique view.
2-55	TM 806-97	Main frame, front panel removed.
2-56	TM 806-98	Main frame, front panel and frequency indicator removed.
2-57	TM 806-116	Radio Transmitter T-195/GRC-19, top deck, tube and resistance diagram.
2-58	TM 5820-335-35-29	Radio Transmitter T-195/GRC-19, bottom deck, tube and resistance diagram.
2-59	TM 806-90	Exciter subchassis, terminal board measurements.
2-60	TM 806-91	Modulator subchassis, terminal board measurements.
2-61	TM 806-60	Power amplifier, terminal board measurements.
2-62	TM 806-93	Discriminator subchassis, terminal board measurements.
2-63	TM 806-94	Antenna-network servo amplifier subchassis, terminal board measurements.
2-64	TM 806-C5-17	High-voltage power supply A1200, voltage and resistance diagram.
2-65	TM 806-95	Main frame, terminal board measurements.
2-66	TM 806-C9-13	Power amplifier subchassis, pa blower, terminal board measurements.
2-67	TM 806-C9-14	Exhaust blower, terminal board measurements.
2-68	TM 806-C9-15	Low-voltage power supply, terminal board measurements.
2-69	TM 806-C9-16	High-voltage power supply, terminal board measurements.
2-70	TM 806-C10-10	High-voltage power supply PS602, terminal board measurements.

## LIST OF ILLUSTRATIONS—Continued

<i>Fig. No.</i>	<i>IN</i>	<i>Caption</i>
2-71	TM 806-C10-11	Low-voltage power supply PS601 terminal board measurements.
2-72	TM 5820-335-35-32	Master oscillator subchassis, schematic diagram.
2-73	TM 5820-335-35-33	Exciter subchassis, schematic diagram.
2-74	TM 806-128	Power amplifier subchassis, schematic diagram.
2-75	TM 806-130	Modulator subchassis, schematic diagram.
2-76	TM 806-129	Discriminator subchassis, schematic diagram.
2-77	TM 5820-335-35-34	Antenna network servo amplifier, schematic diagram.
2-78	TM 806-134	Antenna tuning capacitor subchassis, schematic diagram.
2-79	TM 806-135	Variable inductor subchassis, schematic diagram.
2-80	TM 5820-335-35-35	Main frame, schematic diagram.
2-81	TM 806-136	Subchassis interconnection, cabling diagram.
2-82(1)	TM 5820-335-35-36-(1)	Radio Transmitter T-195/GRC-19, schematic diagram.
2-82(2)	TM 5820-335-35-36-(2)	Radio Transmitter T-195/GRC-19, schematic diagram.
2-83	TM 806-C6-5	High-voltage Power Supply A1200, (MOD 1) voltages.
3-1	TM 806-120	Variable inductor ribbon replacement.
3-2	TM 806-107	Disassembly of autotune single-turn head.
3-3	TM 806-105	Disassembly of autotune multiturn head.
3-4	TM 806-106	Disassembly of autotune control head.
3-5	TM 806-118	Disassembly of autotune motor head.
3-6	TM 806-89	Lubrication of autotune single-turn head.
3-7	TM 806-111	Lubrication of autotune multiturn head front and top views.
3-8	TM 806-112	Lubrication of autotune multiturn head, left and right views.
3-9	TM 806-110	Lubrication of autotune control head.
3-10	TM 806-109	Lubrication of autotune line shaft.
3-11	TM 806-96	Lubrication of frequency indicator.
3-12	TM 5820-335-35-30	Radio Transmitter T-195/GRC-19, modulator adjustments.
3-13	TM 806-C4-1	Exciter band switch synchronizing position.
3-14	TM 806-124	Antenna tuning capacitor synchronization.
3-15	TM 5820-335-35-31	Output capacitor synchronization.
5-1	TM 806-C5-1	Special test cable, construction details.
5-2	TM 806-C5-2	Physical tests and inspection.
5-3	TM 806-C5-3	Tuning capabilities and power output tests.
5-4	TM 806-C5-4	Modulation test.
5-5	TM 806-C5-5	Frequency comparison and operation tests.
6-1	TM 5820-335-35-40	Frequency and output power tests.
6-2	TM 5820-335-35-41	Modulation capability and microphone input tests.
6-3	TM 5820-335-35-42	Audio frequency response, distortion noise and series clipping operations tests.
6-4	TM 5820-335-35-43	Sidetone output test.
6-5	TM 5820-335-35-44	Remote control operation test.
6-6	TM 5820-335-35-45	FSK operation test.
6-7	TM 5820-335-35-46	Low voltage operation test.
7-1	TM 806-19	Transmitter Control C-822/GRC-19, front panel.
7-2	TM 806-17	Electrical special purpose cable assembly CX-2585/U.
7-3	TM 806-16	Transmitter Control C-822/GRC-19, with back plate removed.
7-4	TM 806-18	Transmitter Control C-822/GRC-19 cording diagram.
7-5	TM 5820-355-35-1	Transmitter Control C-822/GRC-19, schematic diagram.
7-6	TM 806-7	Mounting MT-925/GRC-19.
7-7	TM 806-C7-1	Radio Set Control Group OA-1754/GRC.
7-8	TM 806-C7-4	Switching Unit SA-708/GRC, exploded view.
7-9	TM 806-C7-3	Relay Unit RE-479/GRC, exploded view.
7-10	TM 806-C7-5	System simplified schematic diagram using OA-1754/GRC.
7-11	ESC-FM 4113-69	Resistor, Inductor and Capacitor Color Code.



# CHAPTER 1

## FUNCTIONING

### NOTE

Radio Transmitter T-195A/GRC-19 and T-195B/GRC-19 are similar to Radio Transmitter T-195/GRC-19 except for certain differences noted in this manual. All references made to Radio Transmitter T-195/GRC-19 apply to Radio Transmitter T-195A/GRC-19 and T-195B/GRC-19, unless otherwise specified.

### Section I. SYSTEM FUNCTIONING

#### 1-1. Scope

a. This manual contains instructions for direct support, general support and depot maintenance for Radio Transmitters T-195/GRC-19, T-195A/GRC-19 and T-195B/GRC-19. It includes instructions appropriate to direct support, general support, and depot maintenance for troubleshooting, testing, alining, and repairing the equipment, and replacing maintenance parts. It also lists tools, materials, and test equipment for direct support, general support, and depot maintenance. For other applicable instructions refer to Operator's Manual TM 11-5820-335-10 for operator's maintenance and to Organizational Maintenance Manual TM 11-5820-335-20 for

organizational maintenance. Detailed functions are covered in this manual.

b. The reporting of errors, omissions, and recommendations for improving this publication by the individual user is encouraged. Reports should be submitted on DA Form 2028 (Recommended Changes to Publications) and forwarded direct to Commanding General, USAECOM, Materiel Readiness Directorate, Communications and ADP Division, ATTN: AMSEL-ME-NMP-EM, Fort Monmouth, N. J.

#### 1-2. Internal Differences in Models

a. Internal differences are listed in the chart below:

Item	Radio Transmitter T-195/GRC-19	Radio Transmitter T-195A/GRC-19	Radio Transmitter T-195B/GRC-19
1,000-volt dc source -----	Dynamotor D602 -----	Transistorized, high-voltage power supply A1200.	Transistorized, high voltage power supply A1200.
Low-voltage power supply --	Dynamotor D601 -----	Dynamotor D601 -----	Transistorized power supply.
Antenna network servo-amplifier chopper G901.	Vibrator type -----	Transistorized -----	Transistorized.
Exhaust blower B602 -----	Dc motor -----	Dc motor -----	Transistorized dc-to-ac inverter and ac motor.
Pa blower B202 -----	Dc motor -----	Dc motor -----	Transistorized dc-to-ac inverter and ac motor.
Auxiliary dust filter -----	Not included -----	Not included -----	Included.

b. The internal differences that effect maintenance of Transmitters, Radio T-195B/GRC-19 are contact numbers of K602 low-voltage (lv) relay, K608 and K610 autotune relays and K615 antenna relay are shown on charts in para 1-36 and 1-41. The above mentioned hermetically sealed relays are replacements for unsealed relays used in earlier models of T-195/GRC-19.

Transmitters, Radio T-195/GRC-19, T-195A/GRC-19 and T-195B/GRC-19 will be known as T-195/GRC-19 throughout this manual, and called the transmitter.

c. For Radio Transmitter T-195B/GRC-19, an auxiliary dust filter (fig. 1-1) is supplied for use under conditions where a heavy concentration of dust is present such as in desert operations.

The auxiliary filter is used in place of the regular filter, in situations which require its use. To install the auxiliary dust filter, first release the catches on each side of the air intake cover at the lower right center of the front panel; then lift out the cover and the regular filter. Store these two items in a safe place until they are to be reinstalled. Insert the auxiliary filter assembly into the panel opening and lock it in place by closing the catch on each side (fig. 1-2). Clean the filter regularly (para 25c. TM 11-5820-335-10); more frequent cleaning will be needed if dust concentration becomes heavier. *A clogged dust filter will cause transmitter overheating.*

### 1-3. System Application

The transmitter is designed primarily for vehicular installation, and can be used in a radio system for normal, duplex, or relay operation. It is part of Radio Set AN/GRC-19, the major components of which are the transmitter, and Radio Receiver R-392/URR.

a. The block diagram (fig. 1-3) shows Radio Set AN/GRC-19 connected for cw or voice transmission in normal operation, and using remote control. A 50-ohm unbalanced line is used to connect the transmitter to a fixed antenna, and a whip antenna is used for vehicular installations. As shown in figure 1-3, audio or cw signals are applied to the transmitter through the remote control unit. In addition, the transmitter can be turned on or off, and channel selection can be made at the remote control location. A

set of headphones provides for reception, and for monitoring the transmitted signal. Primary power is obtained from a 24-volt source and is applied to the transmitter. The transmitter and receiver are interconnected so that the transmitter furnishes primary power to the receiver and also controls its antenna and audio output circuits. A common antenna is used; during transmission the antenna is connected to the transmitter, and between transmissions it is connected to the receiver.

b. Radio Set AN/GRC-19 can be used also for relay and duplex operation, in which case separate antennas are used for reception and transmission. The receiver and transmitter then are operated at different frequencies which are separated by at least 1 megacycle.

c. For fsk operation (fig. 1-4), the transmitter is used with a teletypewriter and an external exciter, Modulator MD-203/GR. The output of the master oscillator (mo) is applied, through the MO OUT receptacle, to Modulator MD-203/GR, and the output of Modulator MD-203/GR is fed to the transmitter exciter through the FSK IN receptacle. When the keys of the teletypewriter are in the marking position, the teletypewriter supplies dc signals to the modulator. These dc signals cause the modulator to shift the mo frequency to a higher value. When the keys of the teletypewriter are in a spacing position, the modulator cause the mo frequency to become lower. The overall result is that the radio frequency (rf) output signal is shifted in accordance with the keying action of the teletypewriter.

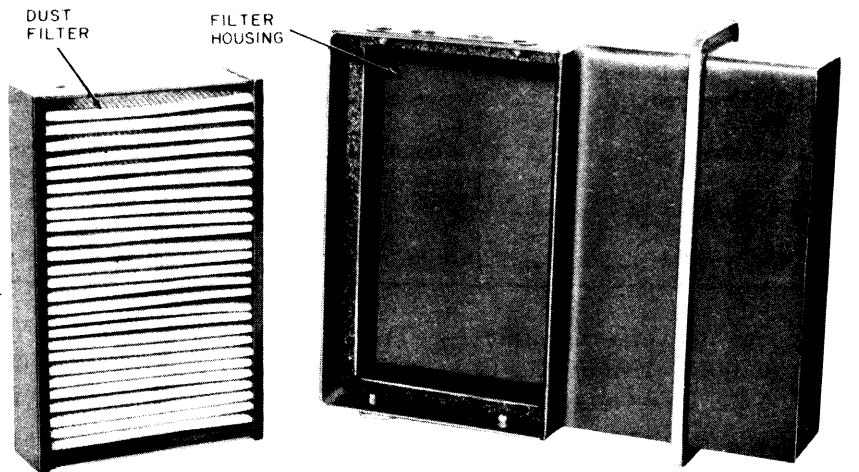

TM806-C8-1

Figure 1-1. Auxiliary dust filter assembly with filter removed.



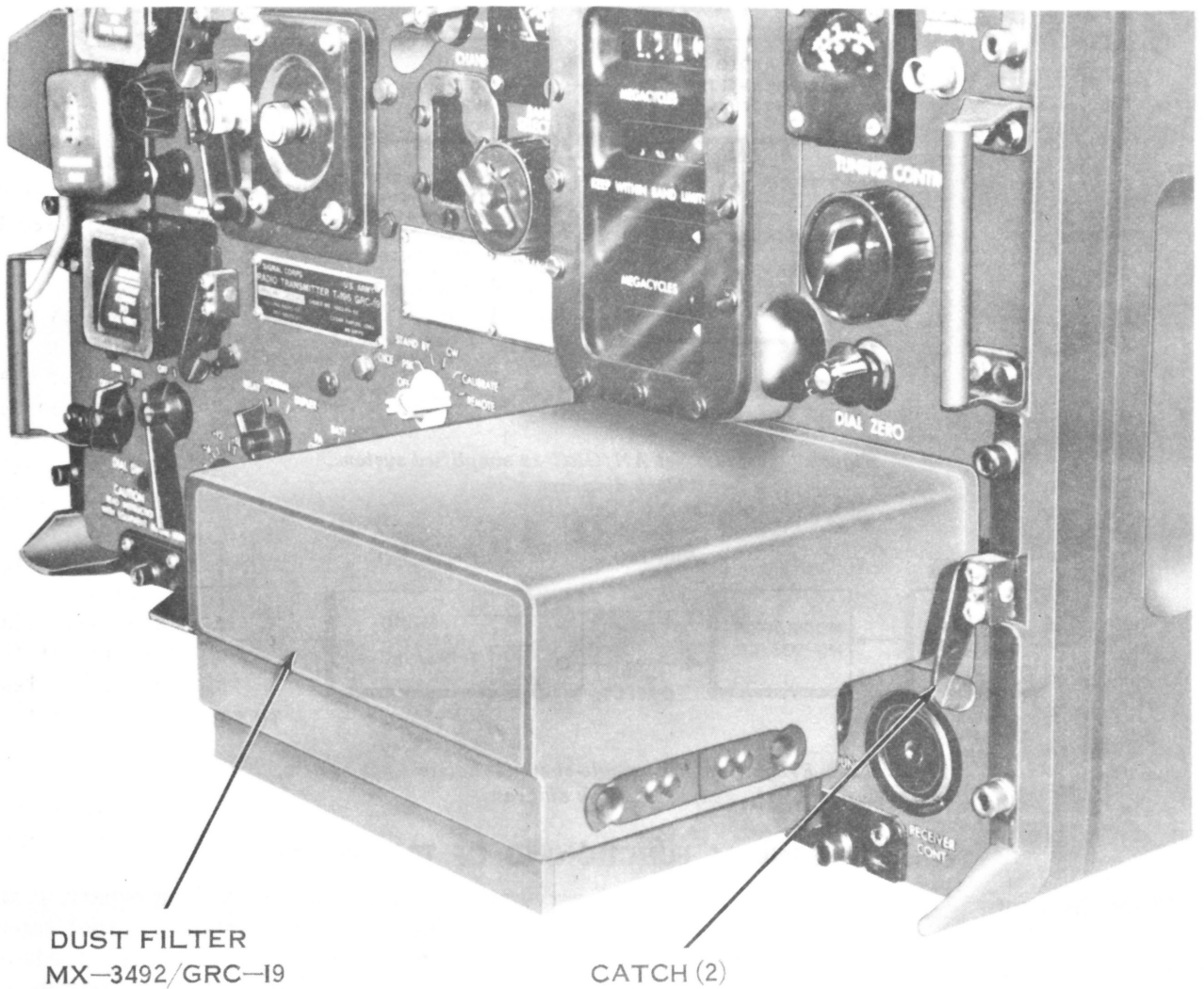

DUST FILTER  
MX-3492/GRC-19

CATCH (2)

TM5820-335-10-5

*Figure 1-2. Auxiliary dust filter assembly installed.*

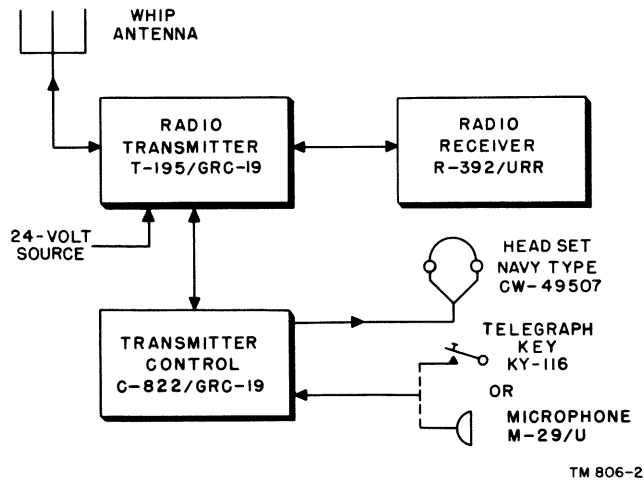

Figure 1-3. Radio Set AN/GRC-19 simplified system block diagram.

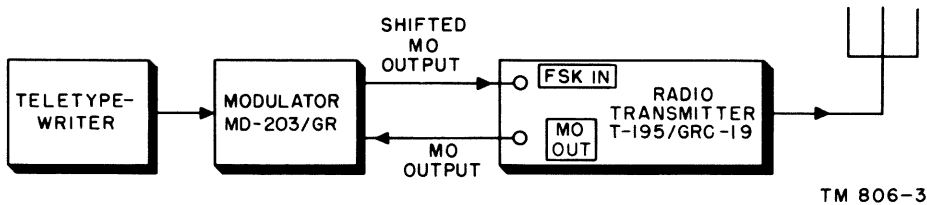

Figure 1-4. Frequency-shift, single-channel radioteletype system, simplified block diagram.

## Section II. GENERAL FUNCTIONING OF TRANSMITTER

### 1-4. Block Diagram (fig. 1-5)

#### a. Signal Circuits.

(1) The master-oscillator subchassis generates an rf signal within the range of 1.5 to 3 mc. This signal is fed to the exciter subchassis, where it is amplified and frequency-multiplied to the desired transmitting frequency. The output signals of the exciter subchassis, in the range of 1.5 to 20 mc, are fed to the power-amplifier subchassis, which applies power to the transmitter antenna circuit.

(2) The af signals from the modulator subchassis are applied to the power-amplifier subchassis to modulate the carrier frequency. The exciter and power-amplifier subchassis normally are inactive, because of bias voltages applied to the grid circuits. When a key or microphone switch is closed, the bias is removed, high voltage (hv) is applied, each subchassis functions to produce its respective output, and power is applied to the antenna circuits of the transmitter.

#### b. Antenna Tuning Circuits.

(1) The antenna tuning system is composed of the discriminator, the antenna network

servo amplifier, the antenna tuning capacitor, the variable inductor, and the antenna output capacitor. It is used to properly match the impedance of the antenna circuit to that of the power-amplifier output circuit (para 1-16).

(2) The discriminator is composed of two independent circuits: the phasing discriminator that controls impedance matching between antenna and pa stages, and the loading discriminator that controls the resistive load of the antenna. Each circuit produces correction or error voltages that are applied to the antenna network servo amplifier.

(3) The antenna network servo amplifier is also composed of two sections; one section amplifies the error voltage from the phasing discriminator, the other section amplifies the error voltage from the loading discriminator. The outputs of the two amplifier sections are applied to the antenna tuning capacitor and the variable inductor subchassis. As a result, the capacitance and inductance are adjusted to transform the impedance of the whip antenna or the 50-ohm un-

balanced line to a purely resistive 73 ohms, as required by the power amplifier.

(4) The antenna output capacitor is composed of a group of fixed capacitors from which can be obtained any one of 10 possible capacitor combinations, depending on the setting of the BAND SELECTOR control. The output capacitor narrows the range over which the antenna tuning circuits must tune.

(5) An antenna switching circuit connects the antenna to the transmitter during transmission, and to the receiver, through J616, when the transmitter is not being keyed. This arrangement makes possible the use of a single antenna for transmission and reception, without damaging the input circuits of the receiver during transmission.

(6) Two antenna receptacles are mounted on the front panel of the transmitter: the WHIP ANTENNA receptacle, J615, and the 50 OHMS OUTPUT receptacle, J614. The antenna interlock switch, S613, has an actuating arm on the front panel which covers the coaxial connector, J614. When a 50-ohm antenna is connected to J614, the arm of the switch is moved, connecting J614 to the transmitter output circuit.

*c. Frequency Selection Circuits.* The frequency range of the exciter subchassis is divided into

four bands. The frequency range (1.5–20 mc) of the power-amplifier subchassis is divided into 10 bands. Band selection for the exciter and power-amplifier subchassis is controlled by a single turn Autotune positioning head that is controlled by the Autotune control head for automatic tuning or by a front panel control for manual tuning. Tuning within the band selected is accomplished by use of a multiturn Autotune positioning head that is controlled by the Autotune control head for automatic tuning or by a front panel control for manual tuning. The multiturn positioning head simultaneously positions tuning cores in the master-oscillator and the exciter subchassis so that proper frequency tracking occurs through all bands. The position of the PRESET CHANNELS switch, during automatic tuning, determines the channel or preset frequency to which the Autotune control head will adjust.

*d. Power Circuits.* Power for the transmitter is supplied by two dynamotors or transistor-type power supplies. The high-voltage dynamotor furnishes +1,000 volts to the modulator and power amplifier subchassis, and the low-voltage dynamotor or transistor-type power supply furnishes all other operating voltages except tube filament and control circuit voltages, which are supplied directly from the 24-volt source.

### Section III. FUNCTIONING OF MASTER-OSCILLATOR STAGES

#### 1-5. Block Diagram

(fig. 1-6)

All transmitting frequencies of Radio Transmitter T-195/GRC-19 are multiples (1, 2, 4, and 8) of the frequencies generated by the master oscillator. This subchassis contains two 5749 tubes, V801 and V802.

*a.* The oscillator tube, V801, is slug tuned, and generates a frequency in the range of 1.5 to 3 mc. Tuning is controlled by the TUNING CONTROL.

*b.* The buffer-amplifier tube, V802, amplifies the rf signal generated by the oscillator tube before it is fed to the exciter.

#### 1-6. Oscillator V801

(fig. 1-7)

*a.* Oscillator tube V801, type 5749/6BA6W, is connected in a Hartley circuit, with L801 and L803 serving as the inductive branch of the parallel resonant circuit. C801, C802, C803, and C804, form the capacitive branch of the circuit. Frequency variation is possible through movement of a tuning core within L801. This varia-

tion is controlled by the TUNING CONTROL. A highly critical, variable-pitch winding, L801, produces a linear frequency variation with core movement; L803 is an inductive trimmer that establishes the exact frequency range of the oscillator.

*b.* Resistor R801 and capacitor C805 form the grid bias network. Plate and screen-grid voltages are supplied from the +250-volt supply through voltage-dropping resistor R601 and voltage regulator tube V601. The operating voltage of V601 is 150 volts, so that +150 volts, regulated, is supplied through rf choke L802 to screen-grid resistor R802 and plate resistor R803. C806 is the screen voltage rf bypass. C810 is an rf filter for the +150-volt supply. C666 is added to provide additional filtering on main frame, MOD5A and higher.

*c.* The oscillator tube produces an rf signal in the frequency range of 1.5 to 3 mc, depending on the setting of the TUNING CONTROL. The output of V801 is fed to the control grid of buffer amplifier V802 through coupling capacitor C807.

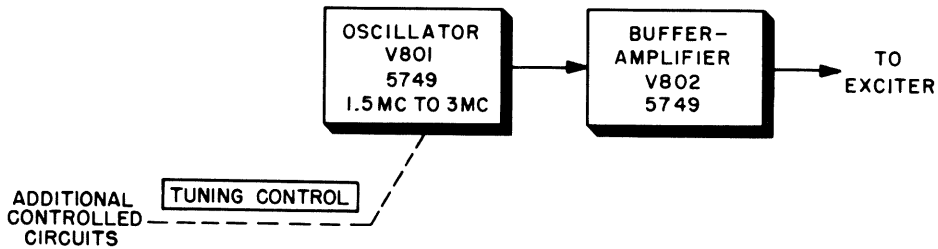

TM 806-22

Figure 1-6. Master oscillator, block diagram.

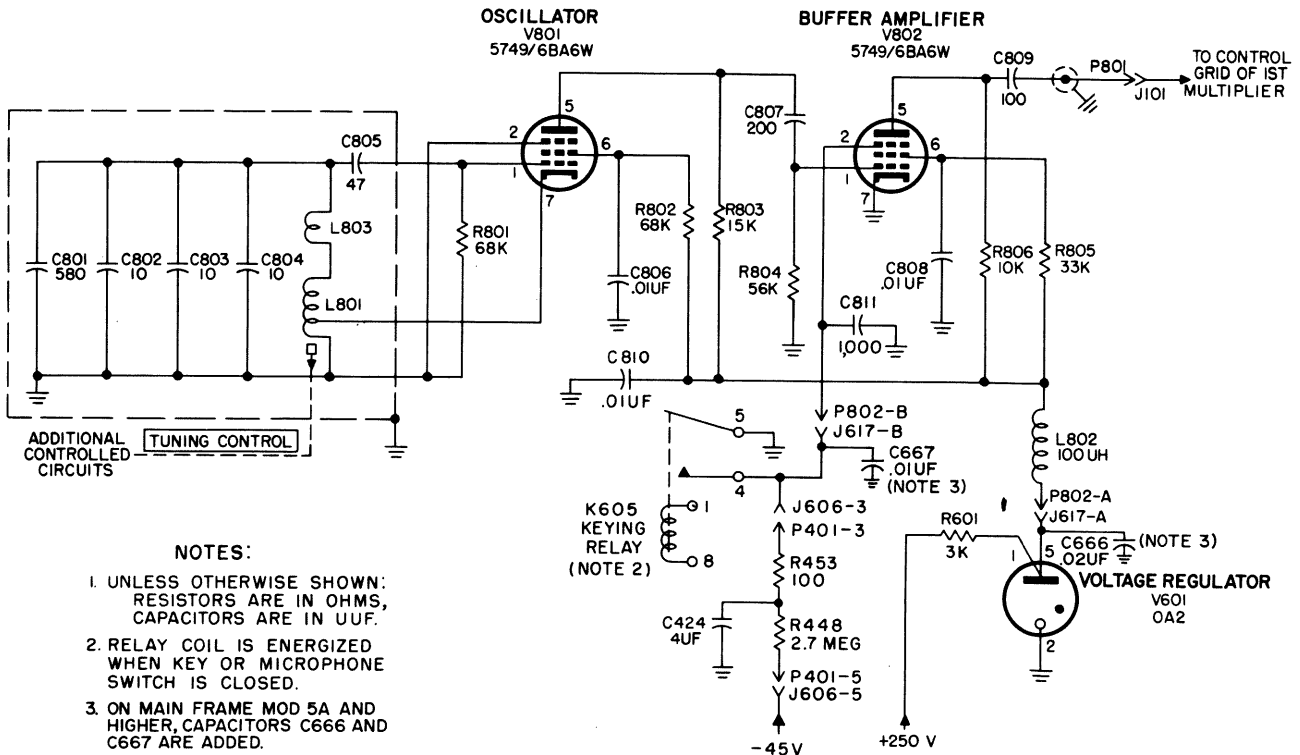

TM5820-335-35-3

Figure 1-7. Master-Oscillator stages, functional diagram.

### 1-7. Buffer Amplifier V802 (fig. 1-7).

Buffer amplifier, type 5749/6BA6W, amplifies the signal generated by oscillator V801. Self-bias for the tube is developed across R804. Between transmissions, when K605 is deenergized, the tube is biased to cutoff by the negative bias applied through R448 and R453 to the suppressor grid. During transmission, K605 is energized and the negative bias is grounded through contacts 4 and 5 of K605. When the biasing voltage is removed, V802 operates in a normal manner and supplies a signal to the exciter. Plate voltage is applied through R806. The screen grid circuit consists of R805 and C808. Capacitor

C811 is an rf filter for the -45-volt supply. Capacitor C667 is added as a filter in parallel with capacitor C811 on main frame MOD5A and higher. The output signal is applied to the exciter through C809, P801, and J101.

### 1-8. Oscillator Frequency Stabilization (fig. 1-8)

Compensation for low-temperature operation is provided by a noninductive heater winding wrapped around the outside of the oscillator can. Thermostat S801, mounted on one end of the can, has a set of contacts in series with the noninductive heater winding. C812 is a spark-suppressing capacitor. When the ambient tem-

perature falls below 0° C. (32° F.) one of the contacts, which is mounted on a bimetallic strip, moves into contact with the stationary contact and applies 24 volts dc to the heater element. Power is continuously supplied to the heater element until the temperature at the thermostat rises above 0° C. (32° F). The oscillator is provided also with a metal shield for preventing extraneous magnetic fields from upsetting the frequency setting.

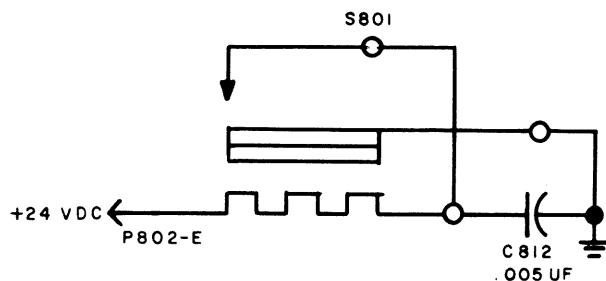

TM5820-335-35-37

Figure 1-8. Thermostat S801, simplified schematic.

## Section IV. FUNCTIONING OF EXCITER

### 1-9. Block Diagram (fig. 1-9)

The exciter is used to amplify the output of the master oscillator and to furnish the desired transmitting frequency to be applied to the power amplifier.

a. The exciter can be set to operate at one of four possible frequency ranges with BAND SELECTOR control S101. The switch selects the proper combination of circuit components in the exciter to provide the desired transmitting frequency band. Tuning through each band is accomplished by using tuning cores in the inter-stage tuned circuits, which are controlled by the TUNING CONTROL.

b. The block diagram of figure 1-9 shows the tubes and tuned circuits used for each band.

(1) The conditions set up for the 1.5- to 3-mc range are shown in A, figure 1-9. The master-oscillator output is applied to first multiplier tube V101, which amplifies the signal. The output of V101 is fed to driver tube V104, through S101F (rear) and S101D (rear). The driver tube amplifies the signal before it is applied to Z107 and then to the power amplifier.

(2) In B, figure 1-9, the exciter is shown with the BAND SELECTOR control set to the 3- to 6-mc band. The first multiplier introduces harmonic frequencies into the output signal. The output of V101 is applied through S101F (rear) to tuned circuits Z101 and Z102, which resonate at the harmonic frequency to which they are tuned. This frequency is in the 3- to 6-mc range, depending on the setting of the TUNING CONTROL. The output of these circuits is applied through S101F (front) and S101D (rear) to driver tube V104, which amplifies the signal. The signal then is applied to Z108 through S101A.

(3) In C, figure 1-9, the exciter is shown with the BAND SELECTOR control S101 set to the 6- to 12-mc range. The operation of the circuit is the same as for the 3- to 6-mc range, except that the output of Z101 and Z102 is applied through S101F (front) to second multiplier tube V102. The frequency of the signal applied to V102 is twice that of the master-oscillator signal. Tube V102 generates harmonic frequencies. The signal then passes the resonant circuits of Z103 and Z104, which are tuned in the 6- to 12-mc range. The output of this circuit then is applied through the band switch to the driver tube, then through Z109.

(4) In D, figure 1-9, the exciter circuit is shown with the band switch set for the 12- to 20-mc range. The circuit operation is the same as that given in (3) above, except that the output of the tuned circuits of Z103 and Z104 (6- to 12 mc) is applied through S101E (rear) to third multiplier tube V103 instead of to V104. Tube V103 causes harmonics to appear in the output signal, which is fed to tuned circuits Z105 and Z106. These circuits are tuned to resonate in the range of 12 to 20 mc. The output of Z105 and Z106 is applied to the driver tube through S101D (rear), where it is amplified and applied to the output circuit of the exciter through Z110.

### 1-10. First Multiplier V101 (fig. 1-10)

The first multiplier uses a miniature pentode tube, type 6AU6WA, to amplify the master-oscillator signals and to generate harmonics in its output circuit.

a. The output of the master oscillator is fed through P801, J101, and coupling capacitor C101 to the control grid of first multiplier tube V101. Frequency-shift operation is made possible by the

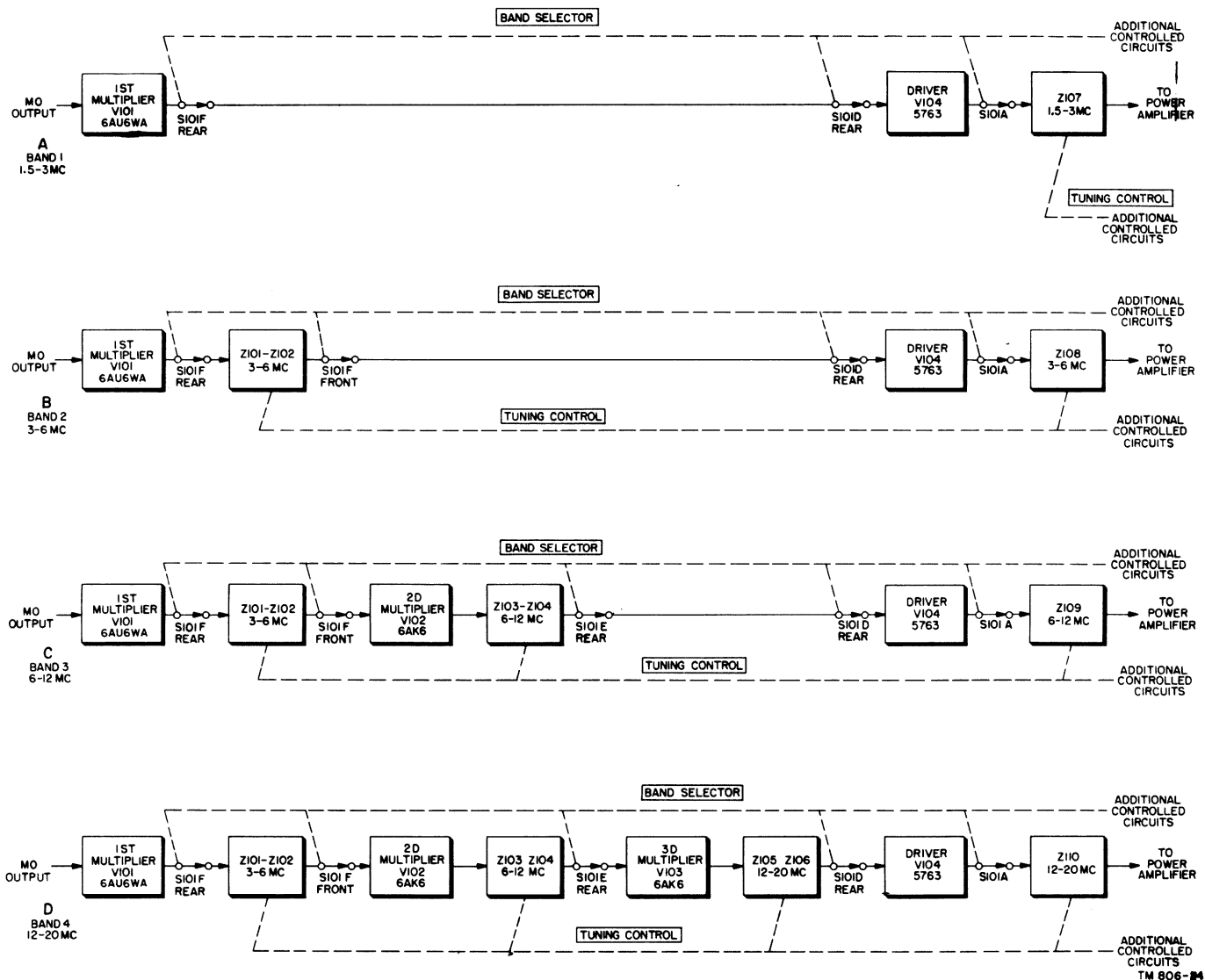

Figure 1-9. Exciter, block diagram.

frequency-shift input circuit, consisting of J613, P601, J102, R122, and L111, through which a signal from an external frequency-shift exciter is applied to the grid circuit of V101. A small amount of grid bias is generated across R101 and R120, but the major source of bias is from the -45-volt keying supply through R119, so that the plate current of V101 is completely cut off when the key or microphone switch is open. When the key or microphone switch is closed, grid bias is generated in the normal manner; fixed bias is grounded through contacts 6 and 7 of keying relay K605. C102 and C134 bypass the control grid return of V101 and also provide a small amount of wave shaping for the keying bias.

b. R102 and C103 provide cathode bias. Screen potential is supplied through R103, with C104

acting as the screen bypass capacitor. C146 decouples V101 plate circuit from the power supply.

c. The position of S101F (rear) selects one of two possible plate circuits for V101. For band 1 (1.5-3 mc.), plate voltage is supplied through R105, and the output signal is applied to the control grid of driver tube V104, through coupling capacitor V106 and S101D (rear). For bands 2, 3, and 4, plate voltage is fed through L101, which, with C107 and C108, form the plate load for V101. This circuit (Z101) is tuned to the second harmonic of the master-oscillator frequency, and is tunable through the range of 3 to 6 mc. Frequency tracking is accomplished by means of the tuning core of L101, which is moved simultaneously with the tuning core in the tuned circuit of oscillator tube V801. C107

is a trimmer capacitor; it is used to obtain more accurate frequency tracking.

d. Capacitor C109 couples Z101 to Z102. Tuned circuit Z102 is composed of L102, fixed capacitor C110, and variable capacitor C111; its circuit action is identical with that of Z101. Capacitors C112 and C113 couple neutralizing voltage from exciter output stage V104 (para 1-14). The 3- to 6-mc output of Z102 is applied to the grid circuit of V104, for band 2, through S101D (rear), or to the grid of second multiplier tube V102, for bands 3 and 4, depending on the position of S101F (front).

### 1-11. Second Multiplier V102 (fig. 1-11)

The second multiplier uses a miniature pentode, type 6AK6, amplifies the signal from the multiplier and generates harmonic frequencies of the signal.

a. When BAND SELECTOR control S101 is positioned to band 3 or 4, rf excitation in the range of 3 to 6 mc is applied to the control grid of V102. Grid leak bias is developed across R106 and cathode bias developed across R107 establishes the desired operating point for the second multiplier V102. Capacitor C114 duplicates the input capacity of the driver stage (V104) so that Z102 is tuned regardless of band selection. C115 is the cathode by-pass capacitor for R107. Plate and screen voltage is applied to V102 from the +250-volt supply and is decoupled by C146. Plate current flow is through L103.

b. The tuned circuit of Z103, consisting of variable capacitor C118, fixed capacitor C119, and L103, is in the plate circuit of V102 and is coupled to Z104 through C120. Z104 consists of L104, fixed capacitor C121, and variable capacitor C122. Capacitors C123 and C124 form a network to couple the neutralizing voltage (para 1-14).

c. The operation of Z103 and Z104 is similar to that of Z101 and Z102, except that they are tuned for a 6- to 12-mc range, and resonate at the second harmonic of the signal applied to the grid of V102. Because the tuned circuits of V101 double the frequency of the master oscillator, the frequency at which Z103 and Z104 resonate is four times that of the oscillator. The output of Z104 is applied to the driver tube, V104, through S101E (rear) and S101D (rear), or to the grid of V103, depending on the position of the BAND SELECTOR control.

### 1-12. Third Multiplier V103 (fig. 1-12)

The third multiplier uses a miniature pentode, type 6AK6, to amplify the signal from the second multiplier, and to cause harmonic frequencies of the signal to appear in its output.

a. If BAND SELECTOR control S101 is positioned to band 4, the rf excitation is applied to the control grid of V103, through S101E (rear). This develops bias voltage across R110. Capacitor C125 duplicates input capacity at V104 so that Z102 will remain tuned, regardless of band selection. Additional bias is developed by the voltage drop across cathode resistor R111. Capacitor C126 bypasses this cathode resistor for rf voltage. The plate and screen supply is bypassed by C128, and plate voltage is fed through L105. The output of V103 is applied to Z105, which is coupled to Z106 through C130. Z105 is composed of variable capacitor C129 and fixed capacitor C105 in parallel with L105. Z106 contains variable capacitor C131 and fixed capacitor C116 in parallel with L106. These two circuits are tuned to resonance in the range of 12 to 20 mc. C132 and C133 provide neutralization voltage for the driver stage (para 1-14).

b. The action of tuned circuits Z105 and Z106 is the same as the action for the circuit previously mentioned. The input frequency of V103 is doubled. This means that the output frequency of Z106 is eight times that of the master-oscillator output. The output of V103 is applied through S101D (rear) to the control grid of V104.

### 1-13. Driver V104 (fig. 1-13)

The driver stage uses a pentode, type 5763, to amplify the output signals of the exciter stages before application to the power amplifier.

a. S101D connects the desired frequency signal to the grid of driver tube V104. The grid bias circuit of this stage operates in the same manner as it does for first multiplier V101. Self bias is generated across R114 when the key or microphone push-to-talk switch is closed. A large negative bias is applied through R119 when the key or microphone switch is open. C134 serves as an rf bypass capacitor.

b. Because a number of factors affect the output from V104, an output control in the form of a variable screen supply is required. This variable screen supply is controlled by S101B, which selects the desired dropping resistance

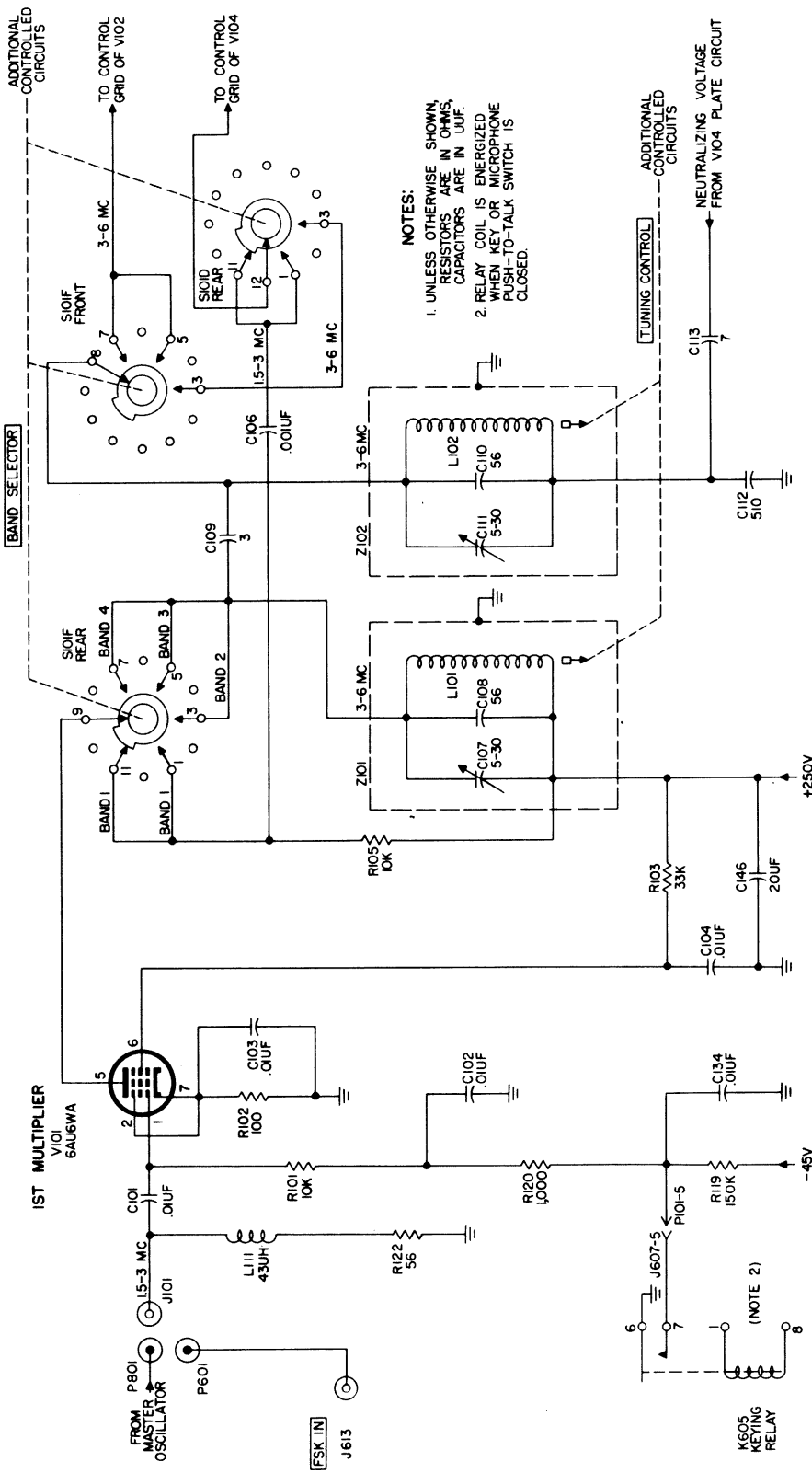

TM 806-25

Figure 1-10. First multiplier stage, functional diagram.



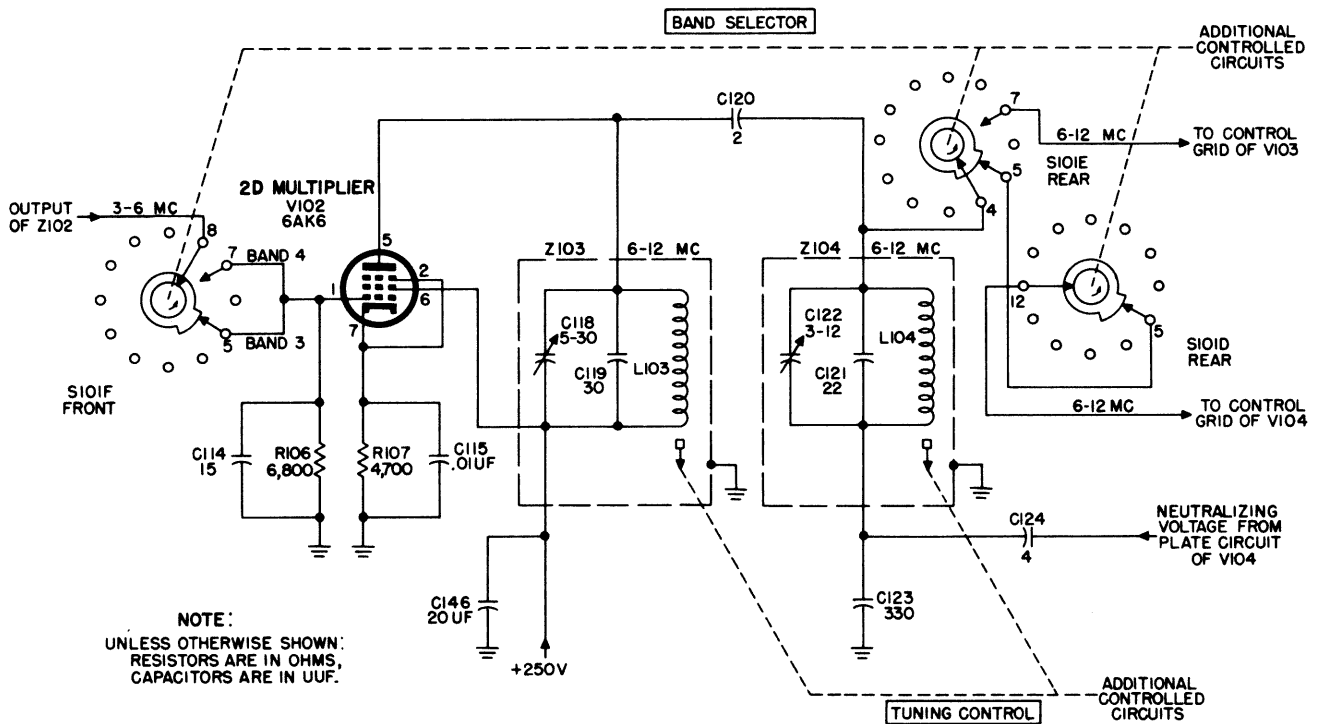

TM 806-26

Figure 1-11. Second multiplier stage, functional diagram.

from the voltage divider composed of R115, R116, R117, and R118. By this means, excitation to the power amplifier of the transmitter is maintained constant, for all operating bands. C135 serves as a screen bypass capacitor.

c. A single tuned circuit is used in the plate circuit of V104; it is selected and tuned as shown below. The desired tuned circuit is selected by S101A. The coils are tuned by means of variable cores and are resonated with fixed and variable capacitors. Plate voltage is fed to the driver stage through a decoupling network consisting of L112 and C143. The output from the exciter, on all bands, is fed through C142 to the grid circuit of power amplifier V201.

Exciter band	Tuned	Frequency range (mc)
1	Z107	1.5 to 3.
2	Z108	3 to 6.
3	Z109	6 to 12.
4	Z110	12 to 20.

### 1-14. Exciter Neutralization

Neutralization is provided for bands 2, 3, and 4 in the exciter to compensate for grid-to-plate capacitance in V104. Figure 1-14 shows the neutralizing circuit for band 2 (3-6 mc), which is comparable to the circuits for bands 3 and 4. This 3- to 6-mc output signal of Z101 is applied through C109 to the grid circuit (Z102) of the driver tube. Internal feed-back voltage (plate to grid) of V104, which may cause undesirable oscillations in Z102, is canceled by application of an external feed-back voltage from the plate of V104, through the voltage divider composed of C112 and C113, to the tuned circuit. Because this feed-back voltage is 180° out of phase with the internal feedback voltage, cancellation of the undesirable voltages occurs.

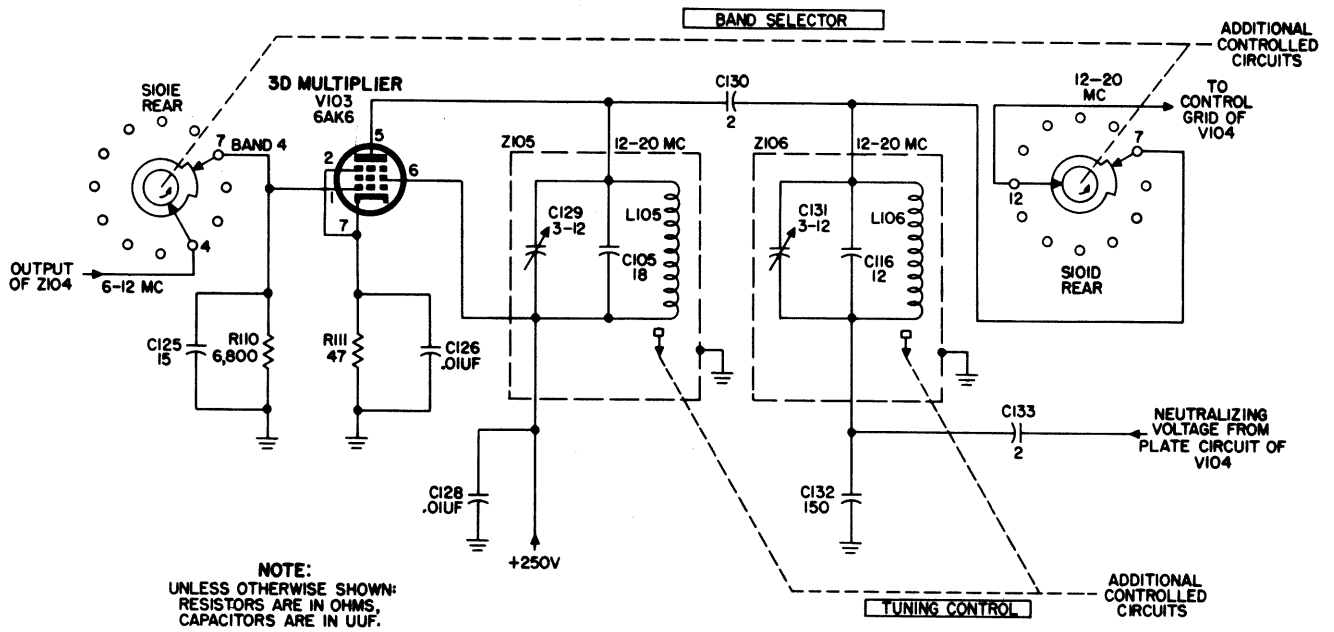

TM 806-27

Figure 1-12. Third multiplier stage, functional diagram.

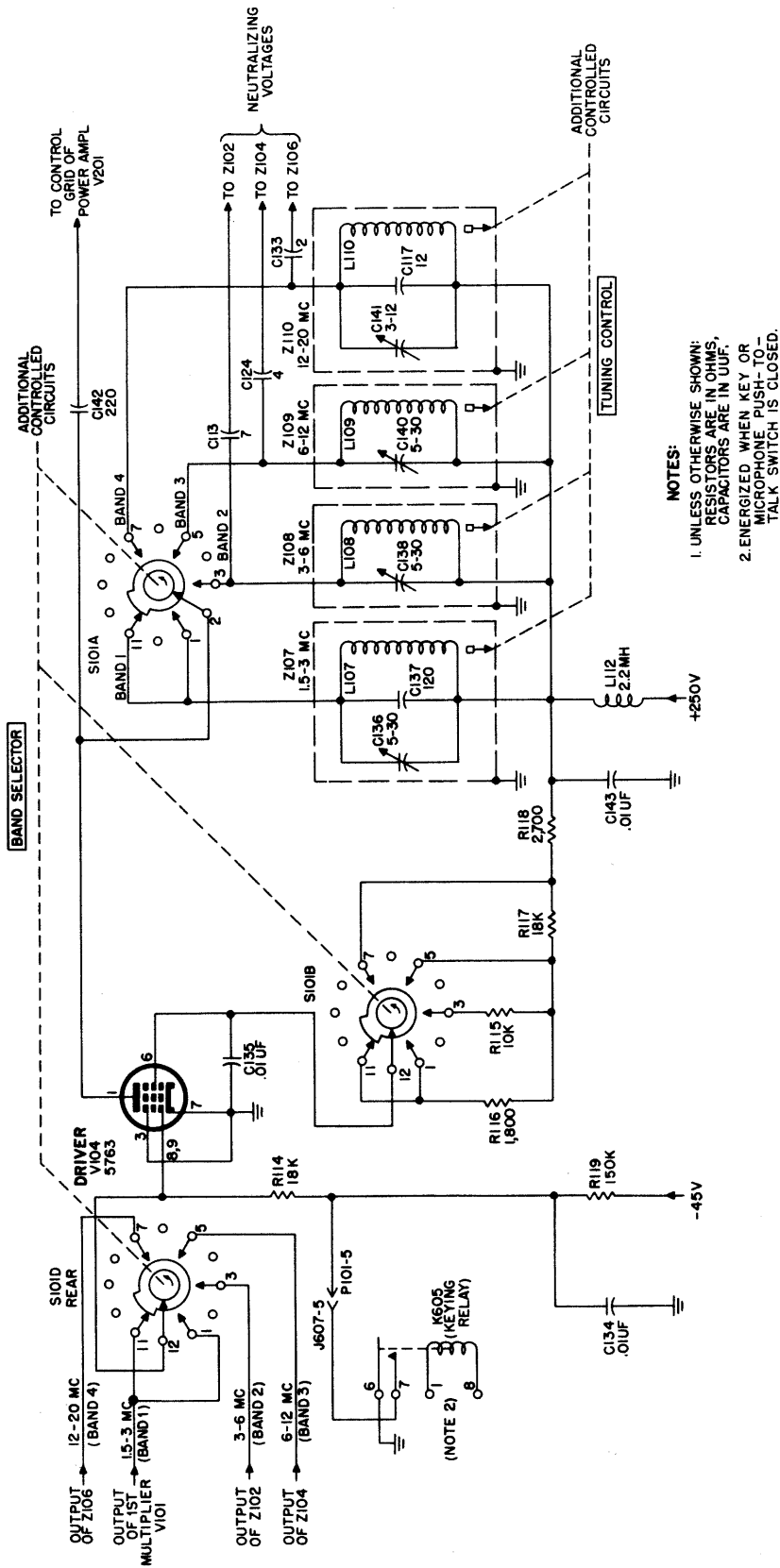

TM 806-28

- NOTES:**
1. UNLESS OTHERWISE SHOWN: RESISTORS ARE IN OHMS, CAPACITORS ARE IN UUF.
  2. ENERGIZED WHEN KEY OR MICROPHONE PUSH-TO-TALK SWITCH IS CLOSED.

Figure 1-18. Driver stage, functional diagram.

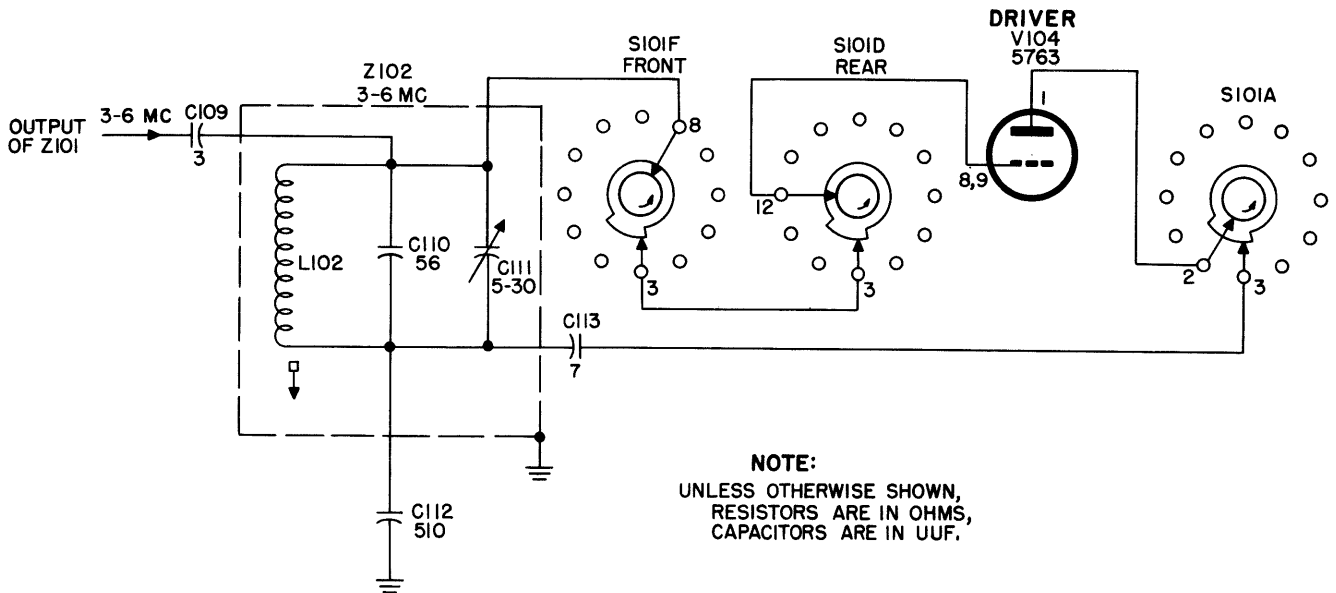

TM 806-29

Figure 1-14. Neutralization circuit, functional diagram.

## Section V. FUNCTIONING OF POWER-AMPLIFIER STAGES

### 1-15. Block Diagram (fig. 1-15)

The power amplifier operates on one of the 10 bands, the selection of which is determined by the BAND SELECTOR. The power-amplifier subchassis contains, in addition to the power-amplifier tube, a protective current-limiting circuit (clammer stage) and a servo system for tuning the pa output circuits.

a. The exciter output signal is applied to the power-amplifier tube, V201, where it is amplified to provide the proper transmitter power output. The output of V201 is fed through L204 to the antenna system.

b. The BAND SELECTOR selects the proper combination of inductors and capacitors that are used in the pa output circuit for the operating band in use. Chokes L202 and L204 are tapped so that sections of the coils are shorted out for certain frequency bands. Each of the variable capacitors, C221 and C222, is composed of two sections, and one or both of these sections are used, depending on the operating band in use. Fixed capacitors C214 through C220, and C223, C224, and C226 through C232, are switched in or out of the circuit, as required.

c. The af signals from the modulator subchassis are applied through L202 and L203 to the plate circuit of the pa tube, and thereby modulate the amplified carrier frequency.

d. Coil L204 is inductively coupled to T201, which samples the power-amplifier output and applies a signal to the discriminator circuit composed of CR201 and CR202. The purpose of the discriminator is to detect a phase shift between the power-amplifier plate and grid voltages and to convert this difference to a dc error voltage. Error voltage will increase or decrease proportionately as the amount of phase shift varies.

e. The dc error voltage is applied to the chopper, G201, where it is converted to a square wave voltage. The output of G201 then is fed to the amplifier section, composed of V204A, V204B, and V203, the output of which is used to rotate servo motor B201; this causes variable capacitors C221 and C222 to vary as required to tune the output circuit of the power amplifier.

f. The clamper, V202, controls the screen voltage of the power-amplifier tube, so that excessive current will not be drawn and damage the tube or its associated circuits when rf voltage is not being furnished by the exciter subchassis.

### 1-16. Power Amplifier V201 (fig. 1-16)

This stage is a class C amplifier, the circuit of which is shown in figure 1-16.

a. The grid circuit of V201 contains L201 and C201, which filter rf from the dc circuits of the

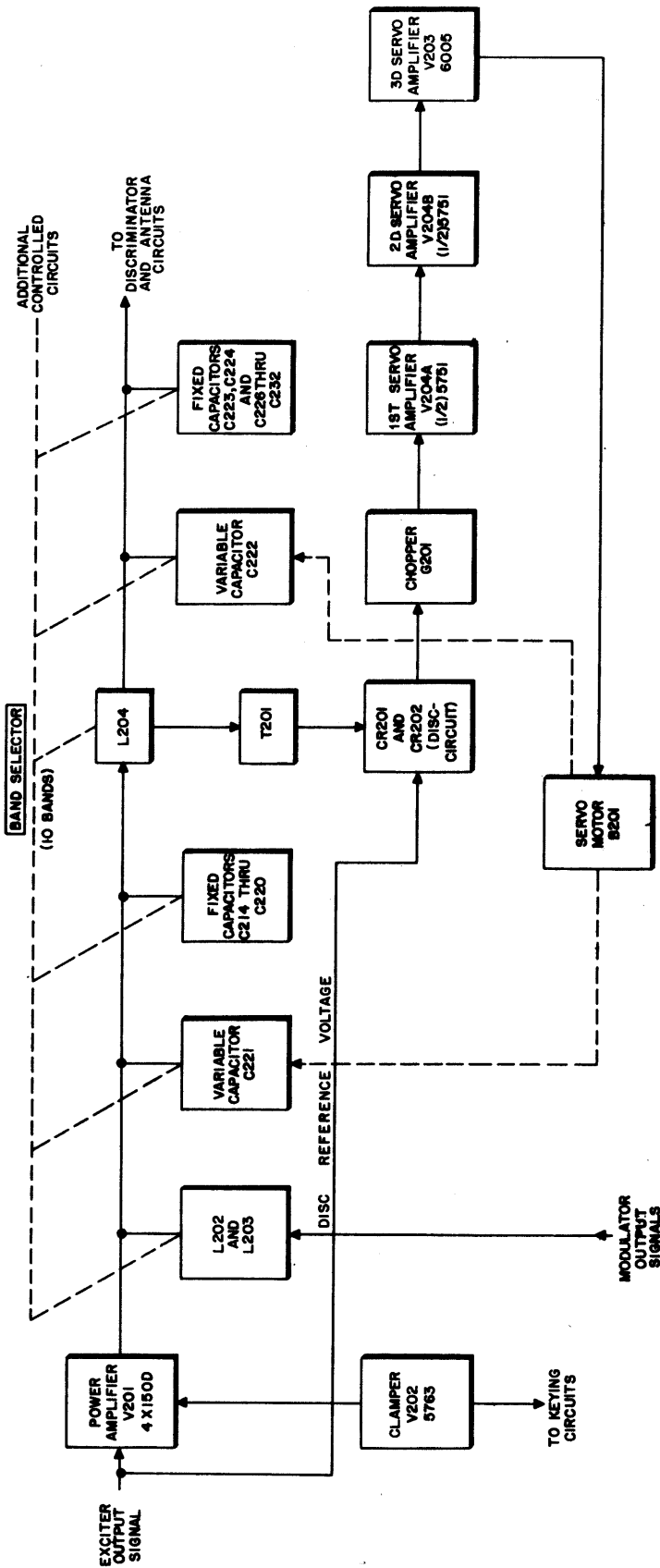

TMB06-30

Figure 1-15. Power amplifier, block diagram.

power supplies and meter M602. Fixed negative bias is obtained from the voltage divider, composed of resistors R204, R232, R203, R612, and R624. This voltage divider is connected between the +250-volt source and the -45-volt source. Resistor R627 furnishes a ground return for grid-leak bias of V201. When TEST METER switch S607 is set to the PA GRID position, the meter leads of M602 are connected through S607 and across R612 to measure the grid current of V201 during transmission. R618 serves as a current-limiting resistor for the meter. A voltage is taken from the control grid of V201 for use in the pa tuning discriminator circuit (para 1-18).

b. The cathode of V201 is connected to ground through part of the heater winding of K202 and meter shunt resistor R613. When TEST METER switch S607 is set to the PA CATH position, meter M602 is connected in parallel with R613 through contacts 11 and 8 of S607, with the negative side of the meter connected to ground through contacts 2 and 5. Meter M602 indicates current drawn by the cathode of V201. Capacitor C247 bypasses rf to ground. Should excessive plate current be drawn by V201, thermal overload relay K202 opens and removes the shunt across the second half of the heater winding and R236. These added resistances, between the cathode of V201 and ground, increase the cathode bias of V201. The increased cathode bias reduces the current flow through V201 to a safe value and prevents damage to V201 and its associated circuits. The additional heater winding will keep K202 open until the transmitter is turned off for a few seconds.

c. The screen grid of the pa tube is connected through voltage dropping resistors R228, R224, and R202, to the +1,000-volt supply. Rf filtering is provided by capacitors C204, C247, and C203.

d. In the VOICE/FSK position of SERVICE SELECTOR switch S606, the coil of transformer shorting relay K203 is energized by completing the coil circuit to ground through contacts 5 and 4 of the switch. This opens the normally closed contacts of the relay, and +1,000 volts, and the af output of the modulator subchassis is applied through rf chokes L202 and L203, and through parasitic suppressor E201 to the plate of V201. In the CW position of S606, the coil circuit of K203 is open, and the contacts of the relay close to short out the secondary winding of T402; this prevents stray af signals from being applied to the plate circuit of the power amplifier. In this condition, the plate voltage is supplied directly from the +1,000-volt supply and through the

closed contacts of K203 to the plate circuit of V201. Rf bypass capacitors C202, C250, and C251 prevent rf voltages from feeding back into the power source. Provision is made to short out rf choke L202 at the higher operating frequencies to prevent self-resonance. In figure 1-16 BAND SELECTOR switch S201B is positioned for the 1.5- to 1.7-mc range. In this position, and in the next four operating bands (1.7-4 mc), L202 is connected in the plate circuit of V201. At the five higher bands (4-20 mc), contacts 12 through 16 are connected to the stationary bar of the switch, and L202 is short-circuited. For bands 8 and 9 (9-16 mc), a center tap of L202 is additionally shorted to each end of the coil. Coupling capacitor C205 feeds the output of V201 to the power-amplifier output circuits.

### 1-17. Clamper V202 (fig. 1-16)

A pentode, tube type 5763, is used for the clamping stage, to reduce the screen voltage of V201 to a safe value of plate current when the keying circuit is open.

a. The control grid of V202 is biased by grid current through R229 when keying relay K605 is not energized, and allows the tube to conduct. When K605 is energized, a negative voltage is applied from the junction of R203 and R204, through contacts 2 and 3 of K605, contacts 4 and 3 of K615, and the normally closed contacts of S203 to the control grid of V202. This causes the clamper tube to become nonconductive. The cathode and suppressor grid of V202 are connected directly to ground, and the screen grid and plate of V202 are tied together and connected to the screen grid of power amplifier V201. When keying relay K605 is not energized, thus allowing V202 to conduct, a reduced voltage is applied to the screen grid of power amplifier V201, and the plate current of V201 is lowered.

b. Wave shaping at the plate of V201 is controlled by C208 and R229, which, because of the time required to charge or discharge C208 through R229, prevents an abrupt change in the screen-grid potential of V201. During keying, when K605 is energized, the negative bias applied to the control grid of V202 drives the clamper to cutoff, thereby increasing the screen grid voltage of V201. The keying relay, when energized, also causes rf excitation to be present at the control grid of the power amplifier, and full carrier appears at the output of the transmitter. The normally closed contacts of S203 will open momentarily during band switch to prevent

keying of the transmitter when the BAND SELECTOR is improperly positioned.

### 1-18. Power-Amplifier Tuning (fig. 1-17)

The tuning circuits of the power amplifier tune the plate circuit of V201 to resonance at the selected frequency. The phase relationship of plate and grid voltages is utilized in the pa tuning circuits to adjust variable capacitors C221 and C222 so that the plate circuit of V201 will be tuned to the output frequency.

*a. Power-Amplifier Plate Circuit* (fig. 1-17). The plate circuit of V201 consists of variable capacitors C221 and C222, plate inductor L204, and fixed capacitors C214 through C220, and C223 through C232. When the BAND SELECTOR switch is operated to select a new operating band, S201A selects the desired value of capacitance from fixed capacitors C214 through C220 and variable capacitor C221. S201D selects the proper value of inductance from tapped coil L204, decreasing inductance as frequency is increased. S201C provides an additional short circuit for sections of L204 to prevent spurious resonant conditions in the unused portions of the coil. The desired value of output capacitance is selected by S201E (front and rear). This switch selects fixed capacitors C223, C224, and C226 through C232 as well as variable capacitors C222A and C222B, as required on each band. Capacitor C225 is in the circuit for all bands. Transmitter bands are as follows: 1.5 to 1.7 mc, 1.7 to 2.0 mc, 2.0 to 2.4 mc, 2.4 to 3.0 mc, 3.0 to 4.0 mc, 4.0 to 6.0 mc, 6.0 to 9.0 mc, 9.0 to 12.0 mc, 12.0 to 16.0 mc, and 16.0 to 20.0 mc. Tuning through the range of variable capacitors C221 and C222 is controlled by servo motor B201 (*b*, *c*, and *d* below). L205 provides a dc path to ground (para 1-31c).

*b. Pa Discriminator Circuit* (figs. 1-18 and 1-19). Tuning within the band selected is accomplished by using a servo tuning circuit, of which the discriminator circuit is a part. Discriminator action is accomplished as follows:

(1) The pa discriminator compares the phase relationship of the V201 output voltage with reference voltage. Any change in the phase relationship between the two voltages causes the discriminator to develop an error voltage. This error voltage is used to adjust the phase relationship to the original condition.

(2) The output of V201 is connected to L204 through parasitic suppressor E201 and dc blocking capacitor C205. T201 is a coil that in-

ductively couples a portion of the V201 rf output to the discriminator. R206 and R207 are the loading resistors for T201. L207 is placed in parallel with R201 in order to improve the pa tuning accuracy at low frequencies. R201 and R205 are balancing resistors to ground for each end of T201. CR201 and CR202 are crystal diode rectifiers. C237 and C238 remove rf from the rectified output, thereby providing a steady dc voltage to the chopper. Resistors R209 and R210 are the load resistors for the rectifiers across which the output voltages are developed. R222 and R223 couple the discriminator output voltages into the low-pass filter composed of C245, R225, and C246. C236, R211, and R212 are used to improve the servo response time and to eliminate hunting of the servo. Resistors R238, R237, and R233 reduce the servo gain to improve the servo loop stability when operating on bands 8, 9, and 10 respectively.

(3) The reference voltage is obtained by use of the phase-shifting circuit, composed of C234 and C235, that is connected between the grid of V201 and load resistor R208. Since capacitive reactance is greater at lower frequencies, compensation is provided to obtain a more uniform phase shift between current and voltage through the entire range of operating frequencies. By adding the capacitance of C235 in parallel with that of C234 at the six lower frequency bands, the capacitive reactance is decreased through the phase-shifting circuit. In figure 1-18, the BAND SELECTOR switch S101D (front) is shown positioned for the 1.5- to 1.7-mc band. In this band and the next five operating bands (1.7-6 mc), the switch completes the coil circuit of K201, which closes the relay contacts and thus adds C235 to the circuit. For the four higher frequency bands, the ground circuit through the S101D (front) is broken, deenergizing K201, which removes C235 from the circuit. The current through the capacitors will lead the rf excitation voltage by approximately 90°, causing a voltage to appear across R208 which leads the grid excitation voltage by 90°.

(4) At resonance, the plate voltage,  $E_p$ , and the plate current,  $I_p$ , are in phase. Since L204 is in an inductive branch of the output circuit (para 2-9c.), current  $I_L$ , through L204, lags  $E_p$  by 90°.  $I_L$  induces in T201 a voltage  $E_s$  which lags  $I_L$  by 90°. A, figure 1-19, shows the phase relationship between  $E_s$ ,  $I_L$ , and  $E_p$ .

(5) The reference voltage,  $E_c$ , is 180° out of phase with the plate voltage before it is shifted. As explained in (3) above, the reference

voltage is shifted ahead  $90^\circ$ ; therefore, the reference voltage,  $E_c$ , and  $E_s$  are  $90^\circ$  out of phase (A, fig. 1-19).

(6) Since R206 and R207 are of equal value, voltage across each,  $E_{R206}$  and  $E_{R207}$ , is equal and is one-half of  $E_s$ . With respect to the center tap of R206 and R207, the voltages are  $180^\circ$  out of phase with each other (B, fig. 1-19). Voltage  $E_{CR202}$  applied to CR202, is equal to the vector sum  $E_c$  and  $E_{R207}$ . B, figure 1-19 shows the phase relationship of the voltages. Rectified current flow through R209 and R210 will be in the direction indicated by the arrows in figure 1-18. When the voltages applied to CR201 and CR202 are equal, equal currents flow through R209 and R210. This results in voltage drops across R209 and R210 which are equal in magnitude but of opposite polarity with respect to their grounded center tap; therefore, no error voltage appears at the center tap of R222 and R223.

(7) Above resonance, the plate circuit becomes capacitive and the current leads the voltage. The current  $I_L$ , through L204 and the induced voltage  $E_s$  will also be advanced from their phases at resonance. The reference voltage,  $E_c$ , will not change in phase. Addition of the two voltages that are applied across CR201 and CR202 results in  $E_{CR201}$  and  $E_{CR202}$  (C and D, fig. 1-19.) Since  $E_{CR201}$  is larger than  $E_{CR202}$ , a greater voltage will be developed across R209 than across R210. This results in a negative voltage equal to half the difference of the two voltages being coupled out of the discriminator.

(8) The development of the discriminator voltages for frequencies above resonance (E and F, fig. 1-19) results in a positive voltage equal to half the difference of the two voltages being coupled from the discriminator. This error voltage is amplified and applied to the servo mechanisms which, in turn, retune the equivalent of C1 and C2 in figure paragraph 2-9c.

*c. Chopper G201* (fig. 1-20). Chopper G201 is used to convert the discriminator error voltage to a positive- or negative-going square wave for application to the pa servo-amplifier circuits.

(1) The error signal from the discriminator is applied to pin 6 of G201. Pin 1 is connected to ground, and exciting voltage (6.3 volts, 400 cps) for the coil is obtained from the output of T901 (located in the antenna-network servo-amplifier subchassis).

(2) The 400-cycle voltage applied to the coil of G201 causes the vibrator, or reed, to make contact with pin 6 and pin 1 alternately. If the discriminator output voltage is negative, the

square wave output of G201 will be negative. If the discriminator output is a positive voltage, the output of G201 will be positive. The output voltages (6.3 volts, 400 cps) of T901 is  $25^\circ$  out of phase with the 115-volt, 400-cycle voltage supplied by low-voltage dynamotor D601 (para 1-43). An additional phase shift of  $65^\circ$  is introduced by the chopper, so that the output signal is  $90^\circ$  out of phase with the output voltage of D601. The output of G201 is a square wave of voltage which leads or lags the 115-volt, 400-cycle output of D601 by  $90^\circ$ , depending on the polarity of the discriminator error voltage. This output is applied through coupling capacitor C239 and the rf filter circuit, composed of R227 and C248, to the control grid of first servo amplifier V204A.

*d. First Servo Amplifier V204A* (fig. 1-20). This stage utilizes one-half of a high-gain miniature, dual triode amplifier, type 5751, to amplify the output signals from chopper G201.

(1) Resistor R219 is the grid resistor, across which self-bias is generated. The cathode is at ground potential and +250 volts is applied to the plate of the tube through R217, R216, and plate load resistor R215. Capacitors C234 and C244 reduce power-supply ripple voltage and also act as decoupling capacitors.

(2) The amplified signals are applied through coupling capacitor C242 to the grid circuit of second servo amplifier V204B.

*e. Second Servo Amplifier V204B* (fig. 1-20). This stage utilizes the other half of the 5751 tube (*d* above) to further amplify the 400-cycle signal.

(1) Resistor R220 serves as the grid resistor for V204B, and additional tube bias is provided by cathode resistor R221. Plate voltage is applied from the +250-volt supply through R217 and R218 to the plate of the tube.

(2) The amplified signals are applied to the grid circuit of third servo amplifier V203 through coupling capacitor C240.

*f. Third Servo Amplifier V203* (fig. 1-20). A miniature pentode, type 6005/6AQ5W, is used for this stage to serve as the power output tube for the servo amplifier.

(1) Control-grid resistor R213 and cathode resistor R214 furnish operating bias for the tube, and screen-grid voltage is fed through R230 from the +250-volt supply. Plate voltage for V203 is applied through a field winding of B201 from the +250-volt supply.

(2) The output voltage of V203 is fed to the field winding (terminals 2-4) of servo motor



B201. Capacitor C241 is part of the tank circuit which acts as the plate load for V203.

(3) The voltage applied to the one field winding (terminals 2 to 4) of B201 is 90° out of phase with the voltage applied to the other winding (terminals 3-1). The direction of motor rotation depends on whether the output of V203 leads or lags the voltage applied to terminals 3

and 1 of the motor (para 1-48). The magnitude of the alternating current (ac) voltages applied to the motor winding is dependent on the magnitude of the dc error voltage applied to the servo system. The discriminator controls the rotation and speed of servo motor B201, which will rotate C221 and C222 required for tuning the power-amplifier plate circuit.

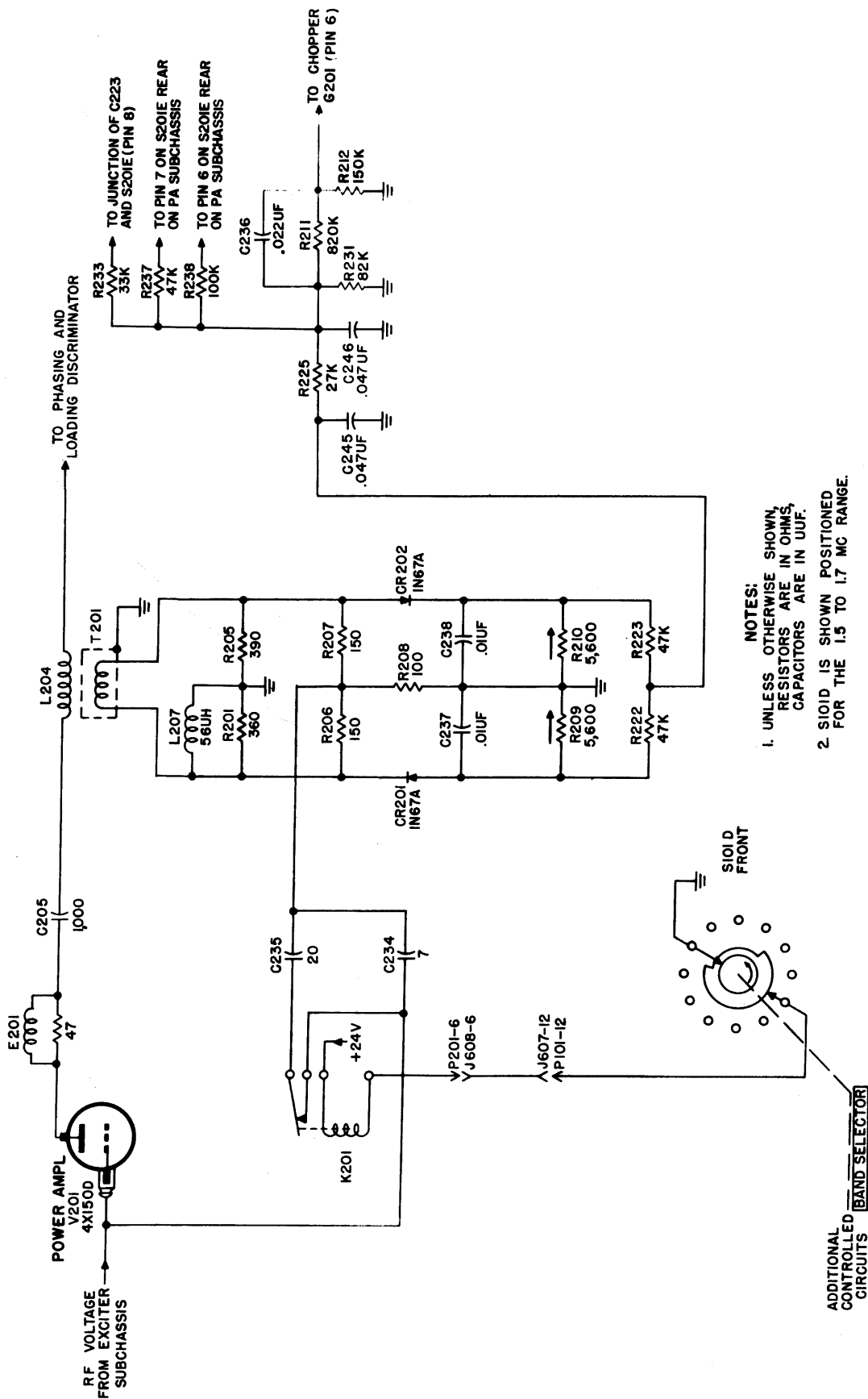

- NOTES:
1. UNLESS OTHERWISE SHOWN, RESISTORS ARE IN OHMS, CAPACITORS ARE IN UUF.
  2. S.I.O.D IS SHOWN POSITIONED FOR THE 1.5 TO 1.7 MC RANGE.

Figure 1-18. Power-amplifier discriminator circuits, functional diagram.

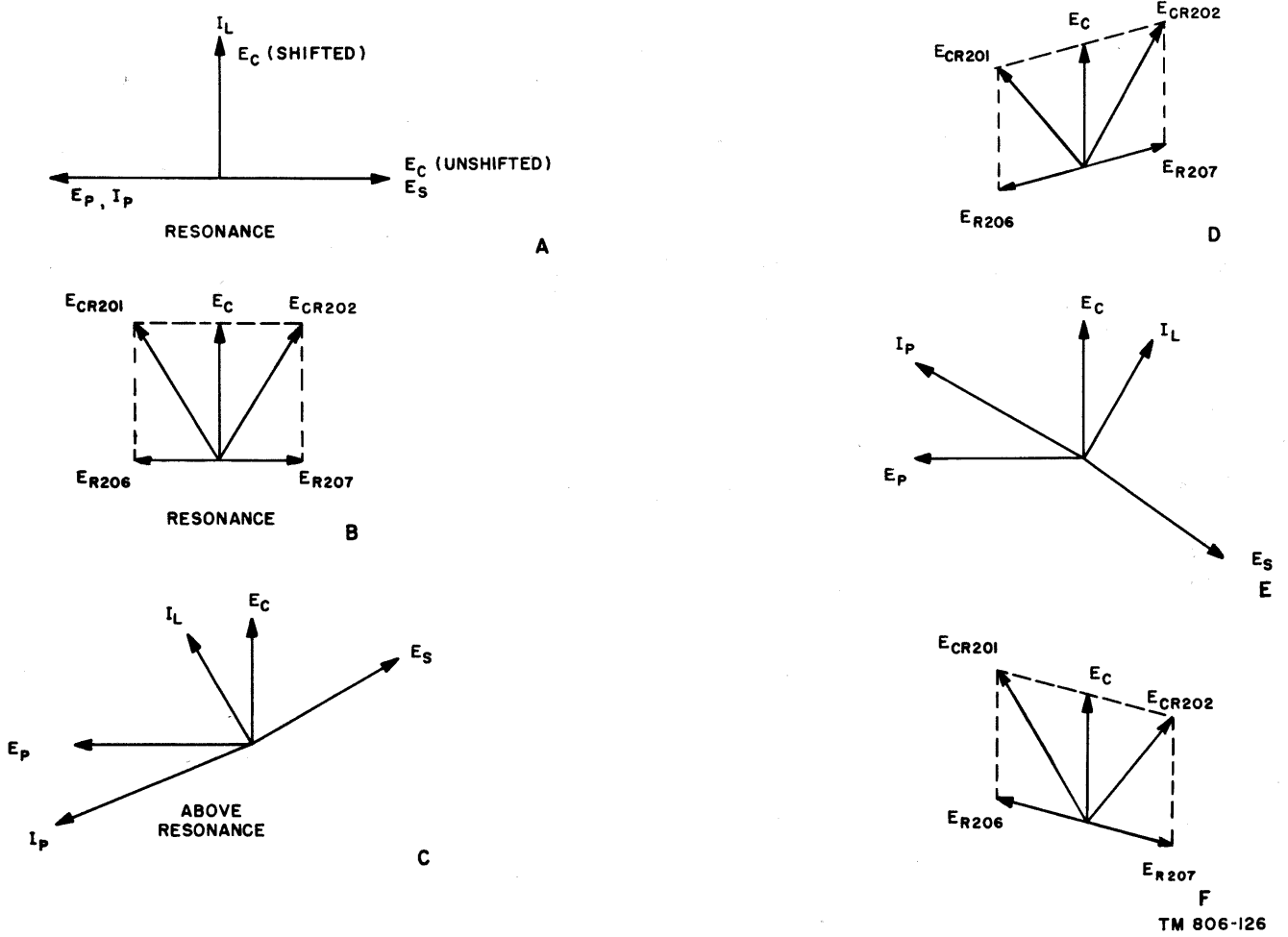

TM 806-126

Figure 1-19. Power-amplifier discriminator.

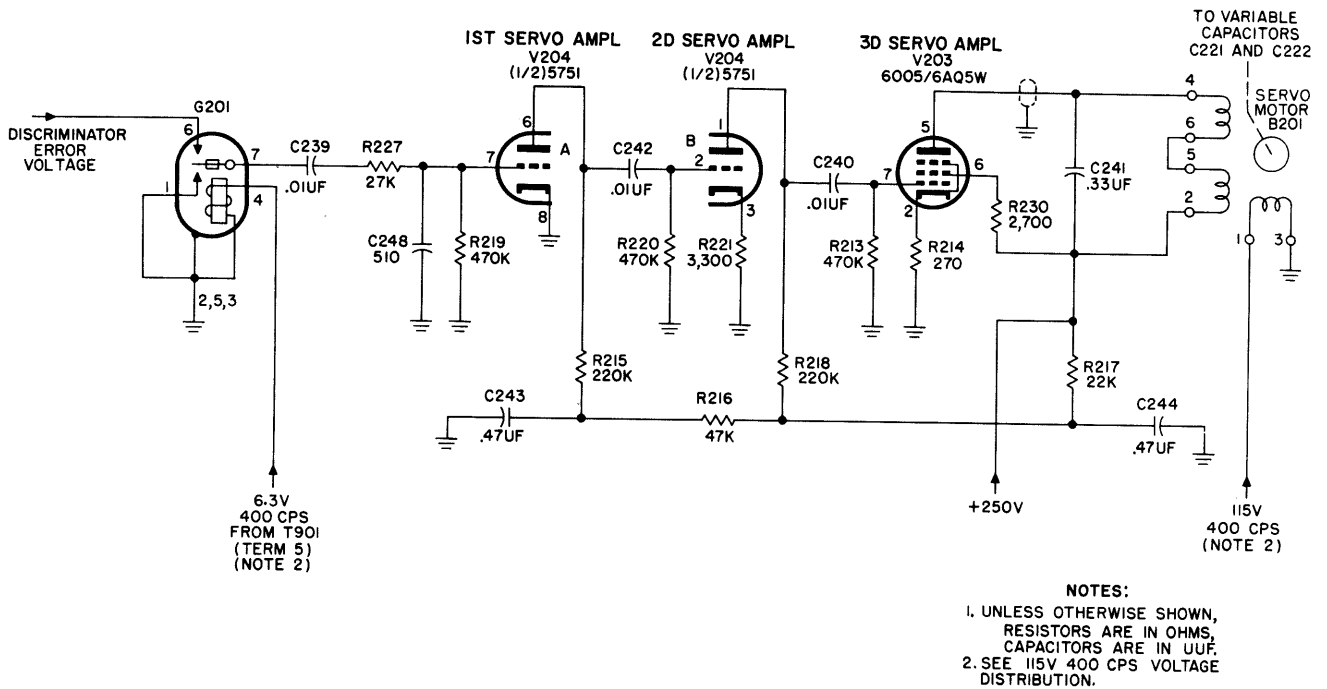

TM 806-34

Figure 1-20. Power-amplifier chopper and servo amplifier stages, functional diagram.

## Section VI. THEORY OF MODULATOR

### 1-19. Block Diagram (fig. 1-21)

The modulator provides the proper audio power to modulate the power amplifier, and furnishes sidetone for monitoring the transmitter.

a. An af signal is fed to preamplifier tube V401A, which amplifies the signal.

b. The af output of V401A is applied to limiter V402. This stage limits, or clips, the negative and positive peaks of the audio signal before the signal is applied to the first audio amplifier.

c. A portion of the audio output of V401A is applied to sidetone amplifier V403A, which furnishes an audio signal to the headset for monitoring purposes. During cw transmission, when the audio circuits of the modulator are disabled, a 400-cycle voltage is fed to V403A through voice relay K402 to monitor the keyed signal of the transmitter.

d. The audio output of the limiter is fed to the first and second audio amplifiers, V401B and V404A, which further amplifies the signal. The output of second audio amplifier V404A is applied to modulator tube V407 and to phase inverter V404B. The phase inverter provides a 180° phase shift in the audio signal applied to modulator tube V406 so that the modulator tubes are operated in push-pull.

e. The push-pull audio output of the modulator tubes is applied to transformer T402, which delivers the af power to modulate the power amplifier.

f. The modulator subchassis contains the antenna delay tube, V403B, but this stage performs no function in the audio circuits (para 1-35).

### 1-20. Preamplifier V401A (fig. 1-22)

The preamplifier stage utilizes one-half of a miniature dual-triode tube, type 12AT7

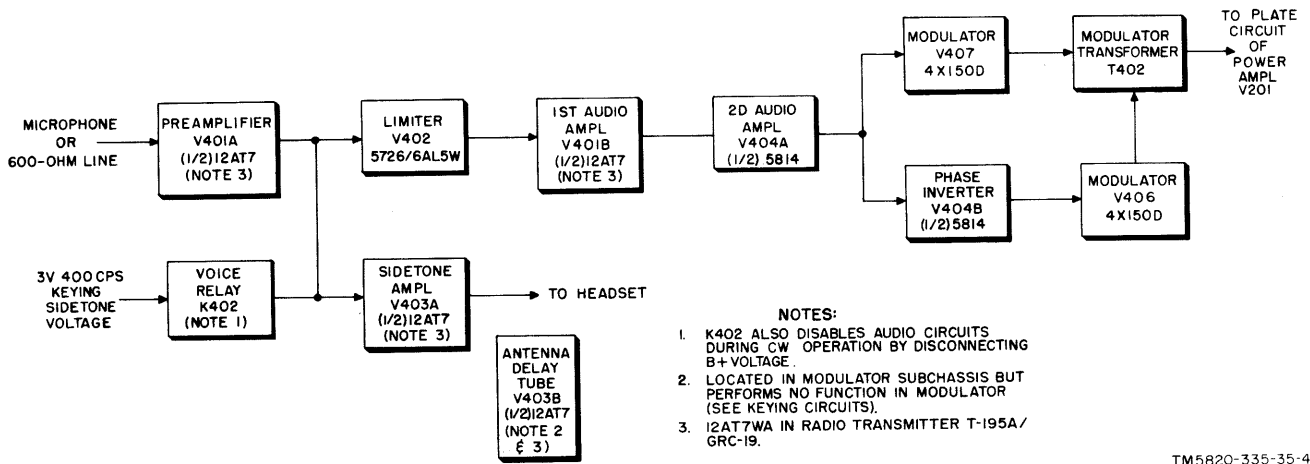

TM5820-335-35-4

Figure 1-21. Modulator, block diagram.

(12AT7WA in Radio Transmitter T-195A/GRC-19) to amplify the audio signals from the microphone or 600-ohm line before they are supplied to the following stages.

a. Audio signals are fed to the preamplifier stage through AUDIO receptacle J603-C, REMOTE CONT receptacle P601-J, or RECEIVER CONT receptacle J604-C. Capacitors C664 and C605 of Z601 filter rf voltages, and the af signals are fed through coupling capacitor C406 and R403 to high pass filter Z401. Resistor R403 and the LINE LEVEL control form a voltage divider for the microphone-output voltage to reduce it to the same level as the 600-ohm line signals. R432, R401, R402, C423, and C402 constitute an RC (resistance-capacitance) filter to remove ripple voltages from the 24-volt power source for application to the microphone line.

b. An audio signal from a 600-ohm line is applied, for relay operation, through AUDIO receptacle J603-A, REMOTE CONT receptacle J601-B, or RECEIVER CONT receptacle J604-H to S602. Capacitors C629 and C613 of Z601 provide rf filtering for the input circuit. When S602 is in the RELAY position, the audio signals are applied through contacts 1 and 2 to the attenuating circuit composed of R604, R602, and R603. Potentiometers R602A and R602B, in conjunction with R603 and R604, provide for adjustment of the audio-input voltage level without changing the impedance of the input circuit.

c. Both the 600-ohm audio-input line and the microphone output are applied to the input terminal of high pass filter Z401. The filter cuts off frequencies below 300 cps; R404 is of the correct resistance to terminate this filter for

proper impedance matching. The audio voltage from the high pass filter is fed through C403 to the grid of preamplifier V401A. Contact potential develops negative grid bias for the control grid of the preamplifier tube across R405. R410 and C407 serve as an rf filter. Plate voltage is fed through R408 and R407 to V401, and C405 serves as an rf bypass. When K605 is de-energized, a negative bias is applied through R119, R405, and R410 to the grid of V401A. This drives V401A to cutoff between transmissions. When the transmitter is keyed, K605 is energized and the negative bias is grounded through contacts 6 and 7. The tube will then operate in a normal manner and amplify the audio signals.

d. The amplified audio signals are fed through coupling capacitor C401 to limiter V402, and through C417 to the sidetone amplifier circuit of V403A.

### 1-21. Limiter V402 (fig. 1-23)

A dual-diode tube, type 5726/6AL5W, is used for the limiter stage, which removes positive and negative peaks of the audio signal.

a. Coupling capacitor C401 feeds audio voltage into MODULATION gain control R419. Audio voltage is connected from the slider of R419 to pin 1 of the limiter, V402. R411 and R416 serve as limiter input and output resistors, respectively. R413 is the common plate resistor. Resistor R414 establishes the level at which clipping starts.

(1) A dc voltage is taken from voltage divider R414 and is applied through R413 to both

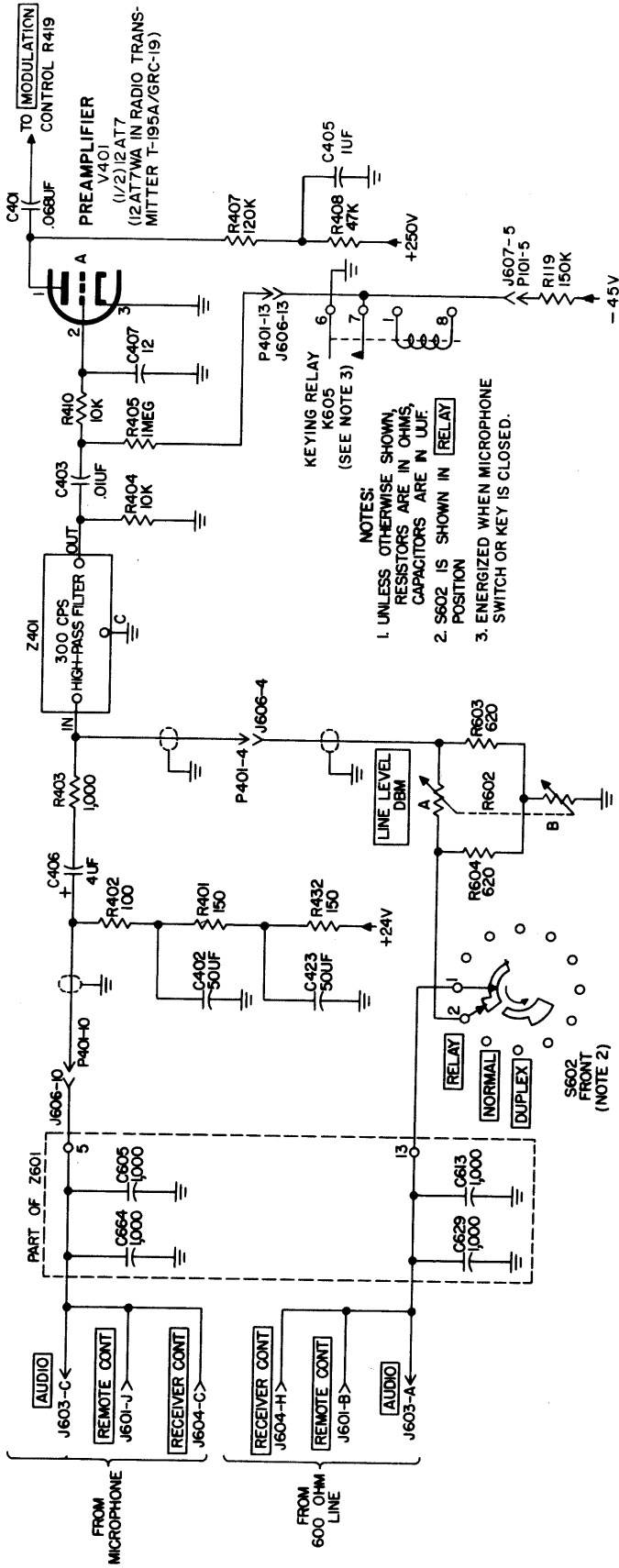

TM5820-335-35-5

Figure 1-22. Preamplifier stage, functional diagram.

plates of V402. Current flows through the voltage divider composed of R421, R409, R414, and R413, and divides through the diode sections of V402 and their load resistors, R411 and R416. The dc voltage drop under static conditions maintains all parts of the circuit as a positive potential above ground. The voltage drop between the plate and cathode of each diode section of V402 is very small compared with the drop across resistor R413.

(2) Limiting does not occur until the peak audio input voltage reaches a value greater than the static voltage at the plates of the diodes. Assume that R414 has been set to a point that will give 1 volt at the plates of V402.

(3) As long as the audio input through C401 is of a magnitude that will not drive the first cathode (pin 1 of V402) more than 1 volt above ground, the plate will at all times be more positive than this cathode, and the tube will conduct. The radio signal developed across R411 will then also appear across R413 and a portion of R414.

(4) Should this input voltage be increased to a value exceeding 1-volt peak, the cathode will become positive with respect to the plate and conduction will stop. The audio voltage developed across R413 will display the original full negative swing, but will be clipped at the arbitrary 1-volt positive level.

(5) The audio voltage developed across R413 is superimposed on a 1-volt dc potential; therefore, only on negative portions in excess of 1-volt peak value will the plate of V402 reach a negative potential with respect to ground. The second cathode (pin 5 of V402), which is at ground potential, will then permit conduction for all signal levels except those which drive the plate of V402 negative. When this occurs, clipping of the negative portion will take place.

(6) The end result of this process is that clipping of the positive half of each cycle takes place in the first diode of V407, and clipping of the negative half cycle takes place in the second diode. In either direction, the voltage may not exceed the clipping level set by adjustment of R414. The clipped voltage will then be developed across R416.

b. The output of the limiter is fed through coupling capacitor C421, which removes the dc component from the audio voltage applied to low-pass filter Z402. The audio output voltage from the filter is within a narrow pass band, with the low frequencies attenuated by Z401

(fig. 1-22) and the high frequencies attenuated by Z402.

### 1-22. First Audio Amplifier V401B (fig. 1-24)

One-half of a type 12AT7 (12AT7WA in Radio Transmitter T-195/GRC-19) dual-triode, V401B, is used to amplify the output signals from the limiter stage.

a. The output signals from the low-pass filter are applied to the junction of resistors R418 and R452. Resistor R452 is the grid resistor. Cathode bias for the first audio amplifier is developed across R420. During voice/frequency-shift keyed operation, voice relay K402 is energized, and +250 volts is fed to the voltage divider composed of R409 and R421. Plate voltage is taken from the junction of R409 and R421 and is applied to the plate of V401B through R422. Capacitor C409 prevents audio voltages from feeding back into the power supply.

b. The amplified af signals are fed to the grid of the second audio amplifier through coupling capacitor C408.

### 1-23. Second Audio Amplifier V404A (fig. 1-25)

One-half of a type 5814 dual-triode, V404A, is used for this stage which further amplifies the audio signals.

a. The output signals from the first audio amplifier are applied to the control grid of V404A. Grid resistor R423 and cathode resistor R424 establish the operating level of the tube, and plate voltage is supplied through R428. Cathode resistor R424 is bypassed to ground by filter capacitor C427.

b. The amplified output signals at the plate of V404A are fed simultaneously to the control grid of modulator tube V407 through coupling capacitor C411, and to the control grid of the phase inverter through coupling capacitor C410, and the voltage divider composed of resistors R427 and R426.

### 1-24. Phase Inverter V404B (fig. 1-25)

The phase inverter, V404B, is used to produce an audio signal of the same amplitude as that of V404A, but 180° out of phase, to provide push-pull audio voltages to the modulator tubes. The phase inversion is accomplished by the additional stage of amplification.

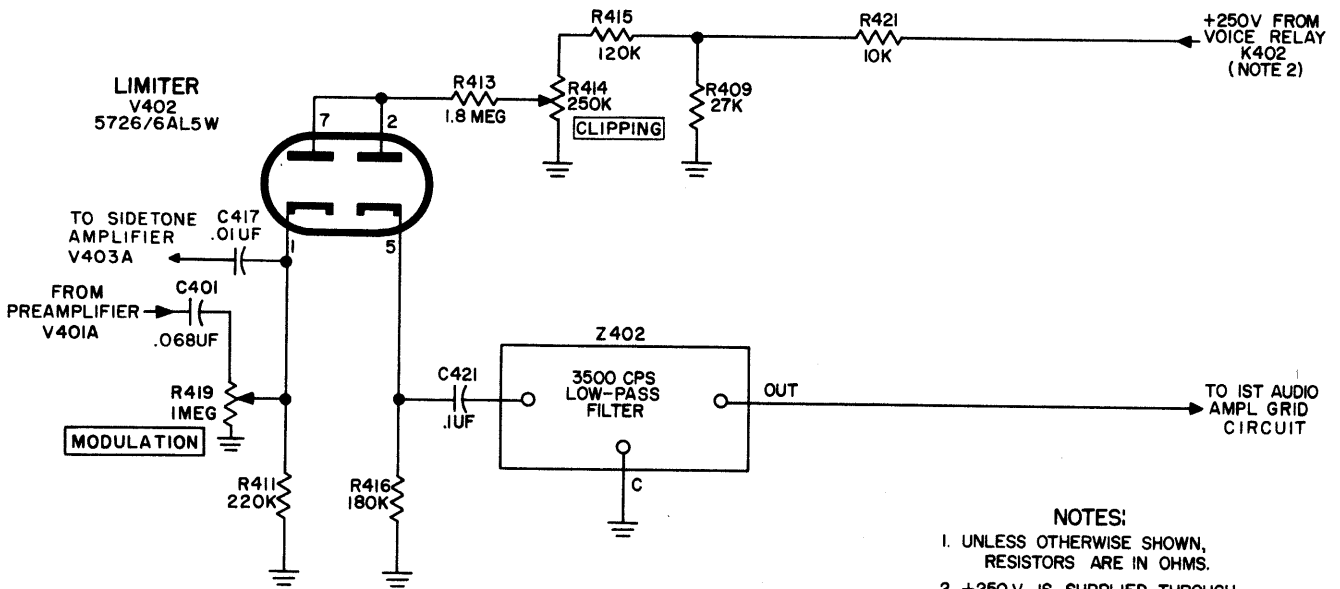

TM 806-37

Figure 1-23. Limiter stage, functional diagram.

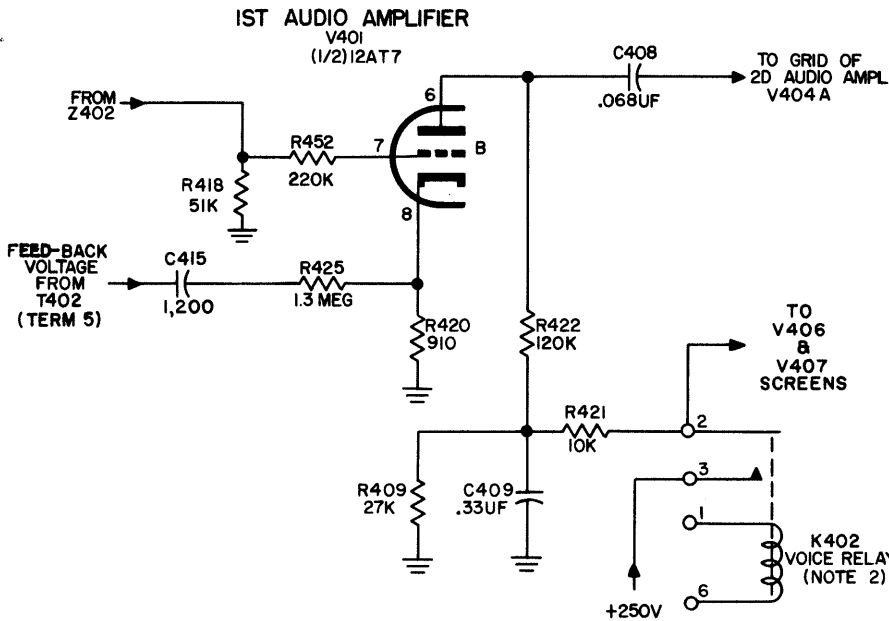

TM 806-38

Figure 1-24. First audio amplifier, functional diagram.

a. The output voltage from V404A is coupled to the grid of V404B at the proper level through C410, R426, and R427. Plate voltage for V404B is supplied through plate resistor R429, and

cathode bias is developed across R424 (common to V404A and V404B).

b. The phase inverter output signals are connected to the control grid of modulator tube V406 through coupling capacitor C412.



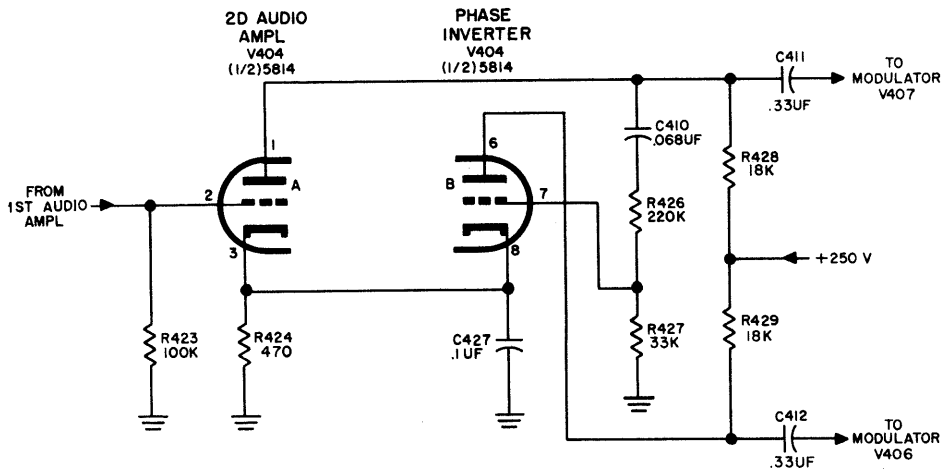

TM 806-39

Figure 1-25. Second audio amplifier and phase inverter, functional diagram.

**1-25. Modulator Tubes V406 and V407**  
(fig. 1-26)

The output signals of V404A and V404B are applied to V407 and V406, respectively. Two tetrodes, type 4X150D, are operated in push-pull for this stage.

a. Audio voltage from the audio amplifier and phase inverter is coupled to the modulator grid circuits through C411 and C412. Negative 45 volts is applied to the modulator grids through R430 and R431 to establish the proper operating point for class AB modulator operation. The primary winding of output transformer T402 is center-tapped to +1,000 volts, which is supplied also to the secondary winding. C659 serves as a filter for this voltage. The +1,000 volts is applied through T402 to the plates of V406 and 407 in parallel, and the cathodes of both tubes are at ground potential. Screen voltage for both tubes is applied directly from the +250-volt power source through contacts 2 and 3 of relay K402 when K402 is energized in the VOICE/FSK position.

b. To secure low distortion, a feedback circuit, consisting of R425 and C415, couples a small audio voltage back to the cathode of the first audio amplifier. This reduces the distortion so that the modulator faithfully reproduces the audio wave applied to the first audio amplifier. The output terminal of modulation transformer T402 is connected to a resistive voltage divider, R439, R440, and R441, to supply voltage to audio level meter M603. Capacitor C601 couples this voltage to M603 through current-limiting resistor R607. The meter indicates audio level in

volume units. To decrease the sensitivity of the phasing amplifier in the antenna servo amplifier, the modulator cathode voltage developed across R433 is connected to the cathode return of the second phasing amplifier, V201.

c. The push-pull audio voltage output of the modulator tubes is applied to the primary winding of T402, and the secondary winding provides af power to modulate power amplifier V201.

**1-26. Sidetone Amplifier V403A**  
(fig. 1-27)

The sidetone amplifier amplifies the audio signals for voice operation and the keyed tone for cw operation.

a. Part of the audio output of the preamplifier is fed to the sidetone adjustment, R436, through coupling capacitor C417, when the transmitter is set up for voice or frequency-shift keyed or voice operation. When the transmitter is set up for cw or frequency-shift keyed operation, voice relay K402 is not energized, and a 400-cycle voltage is fed from the antenna and network servo amplifier through R914, K402, and C420 to R436. The signal is fed to the control grid of V403A at the proper level, as determined by R436.

b. Bias voltage for the grid of the tube is derived from the -45-volt source, which is fed through resistors R119 and R406 to the grid circuit. This negative bias keeps the tube at the cutoff point. When keying relay K605 is energized, the junction of R406 and R119 is grounded; this removes the negative bias and allows V403A to conduct. Additional bias volt-

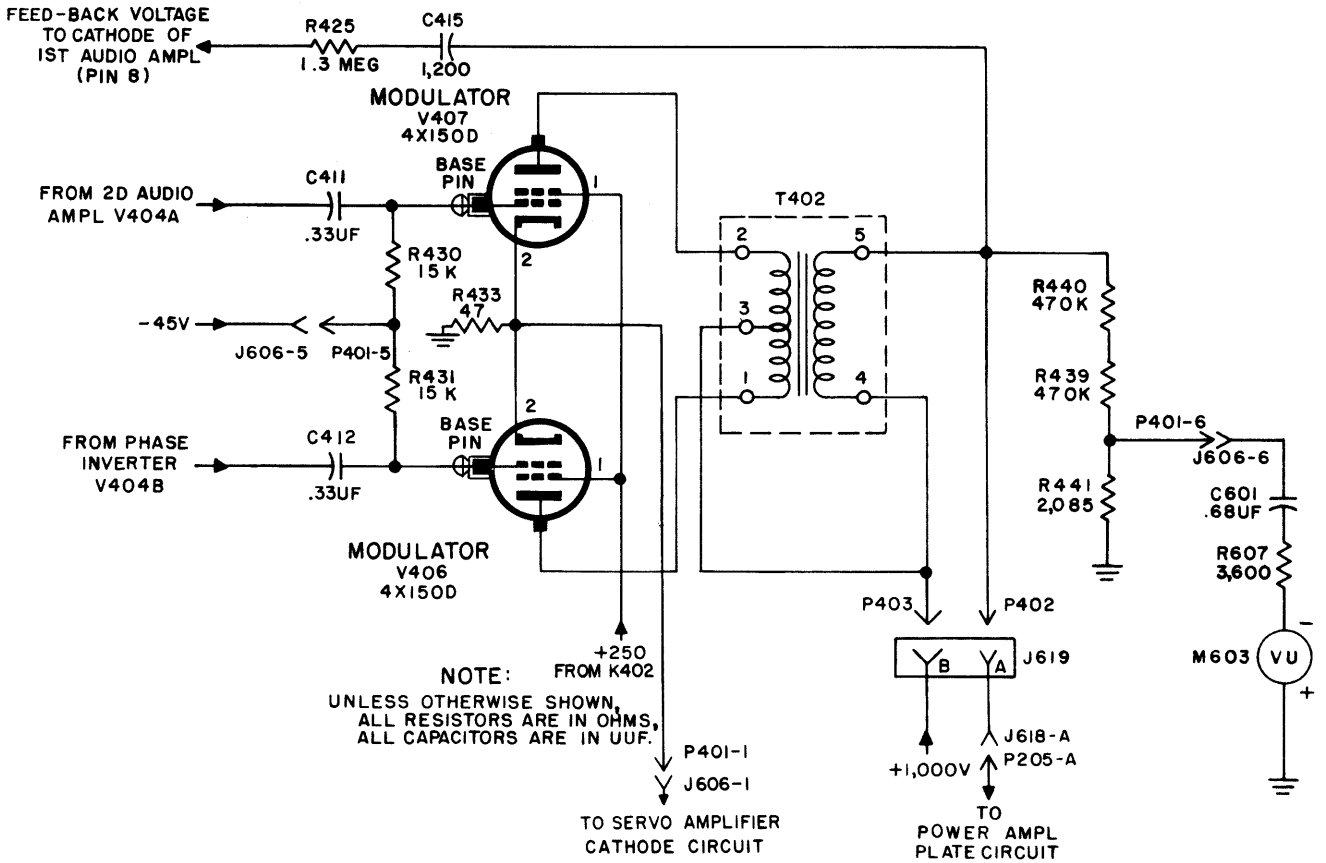

TM 806-40

Figure 1-26. Modulator stage, functional diagram.

age is developed across R437, connected between cathode and ground. Plate voltage for the tube is supplied from +250 volts through the primary winding of T401.

c. When V403A conducts, the audio signal, or 400-cycle voltage, is amplified and applied from

the plate to output transformer T401. When S602 is in NORMAL position, the sidetone voltage is fed through contacts 3 and 1 of the switch to the rf filter circuit composed of C613 and C629, and to the output receptacles to the 600-ohm line for monitoring purposes.

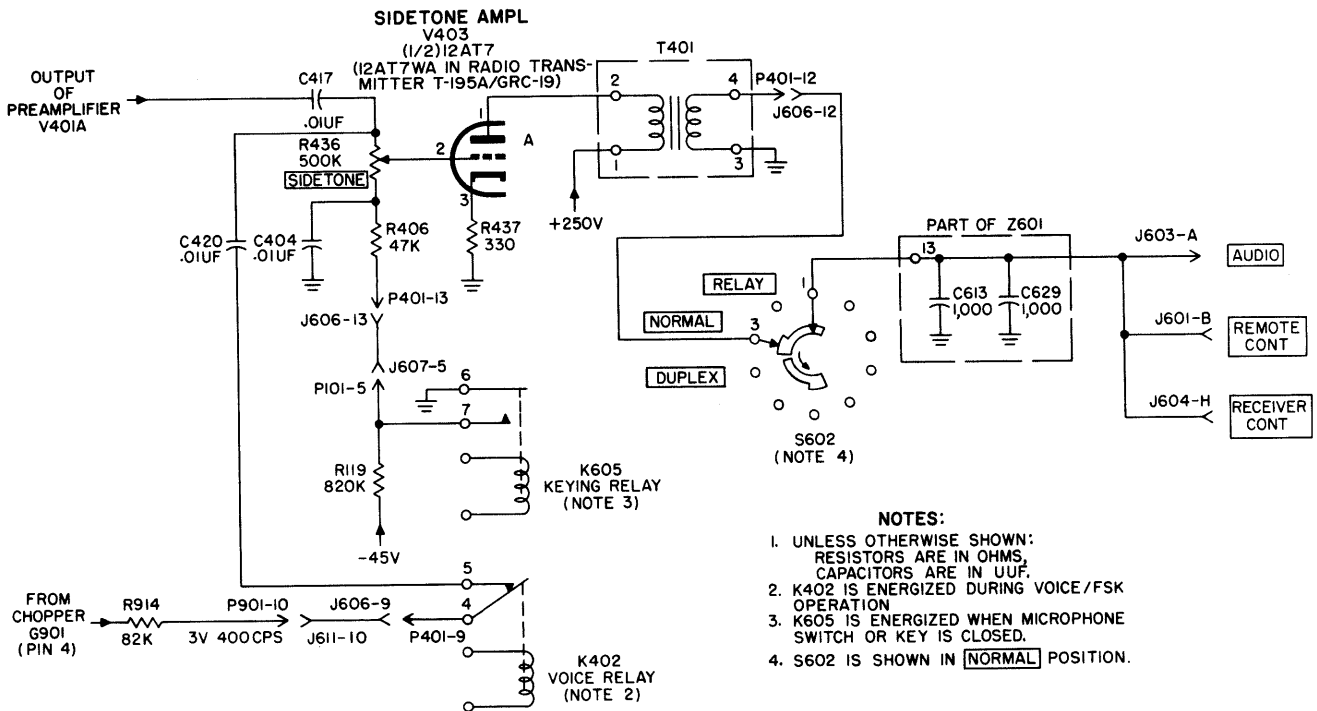

TM 5820-335-35-6

Figure 1-27. Sidetone amplifier stage, functional diagram.

## Section VII. FUNCTIONING OF ANTENNA TUNING SYSTEM

### 1-27. General

a. The antenna tuning system is used to provide proper loading for the pa, to provide an antenna impedance of 73 ohms, and to match the antenna impedance to the pa plate load, so that maximum rf power is radiated.

b. As shown in figure 1-28, the antenna tuning system can be divided into the following three sections:

(1) The pa tuning circuits that provide the plate load for the pa tube.

(2) The antenna, which will present an impedance to the antenna matching network.

(3) The antenna matching network which will match the pa plate load to the 73 ohms impedance of the antenna.

c. The pa tuning circuit consists of an output capacitor (C1), an inductor (L204), and an output capacitor (C2). These components are shown in equivalent form in figure 1-28; for schematic diagram see figure 1-17. If the pa plate circuit is not properly tuned, capacitive or inductive reactance will cause the phase shift between the pa grid voltage and the pa plate voltage to vary from 180°. This phase shift is interpreted by the pa discriminator as an error voltage that is used

to control the amount of capacitance of C1 and C2. Refer to paragraph 1-18b.

d. When the output circuits are properly tuned for a given frequency, they are in a resonant condition and the current and voltage are *in phase*. A change in frequency will result in a nonresonant condition in the output circuits of the transmitter will result in an *out-of-phase* condition of current and voltage in the antenna matching network. The output circuits then become either inductive or capacitive, and the current in the antenna matching network leads or lags the voltage. Because of this out-of-phase condition, the phasing discriminator functions to restore the *in-phase* condition of the antenna and output circuits by increasing or decreasing the capacitance of the antenna tuning capacitor. Refer to paragraph 1-30.

e. With a change in frequency, the output impedance of the antenna matching network also changes. A change in impedance causes a change in the relative amplitudes of voltage and current in the antenna matching network. These amplitudes normally have a ratio of 73 to 1. Any deviation from this ratio will cause the loading discriminator to produce an error voltage (para 1-

30). The error voltage causes the variable inductor to be changed in value until the proper ratio and, therefore, the proper output impedance is obtained (para 1-30). At the same time, the antenna tuning capacitor is adjusted by the phasing discriminator until the antenna matching network is in a resonant condition with an output impedance of 73 ohms.

*f.* The output capacitors are connected in parallel with the antenna at the low end of the transmitter frequency range, in series with it at the middle frequencies, and in series and in parallel with it at the high end of the range. They decrease the tuning range that the matching network must cover in the following manner:

(1) From 1.5 to 3 mc, the antenna has a high capacitive reactance. The antenna tuning capacitor and the variable inductor do not vary over a range wide enough to compensate for this high capacitive reactance. By adding shunt capacitance, the high capacitance reactance is decreased enough, so that the range of the antenna tuning capacitor and the range of the variable inductor are sufficient to tune the circuit.

(2) From 3 to 9 mc, the antenna has a lower capacitive reactance. The tuning range of the antenna tuning capacitor and the variable inductor are sufficient to tune the circuit; therefore, no output capacitors are necessary.

(3) From 9 to 12 mc, the antenna becomes inductive. The output capacitors are placed in series with the antenna. Their reactance is sufficient to cancel the inductive reactance of the antenna and make the antenna slightly capacitive. When the antenna is capacitive, the antenna matching network can tune it.

(4) From 12 to 20 mc, the antenna is inductive and its impedance is much higher than 73 ohms. The output capacitors are added in series and in parallel to provide an antenna circuit which is slightly capacitive with an impedance of 73 ohms. Then the antenna matching will have sufficient tuning range to tune the circuit.

## 1-28. Block Diagram (fig. 1-29)

*a.* The antenna tuning capacitor, the variable inductor, and the antenna output capacitor comprise a tuned circuit. The antenna tuning capacitor and the variable inductor are controlled by the homing circuits and the discriminator. The output capacitor, controlled by motor switch relay K613, is energized when the BAND SELECTOR control is moved to a new position.

*b.* The complete tuning cycle for the antenna output network can be divided into two parts as follows:

(1) The homing cycle places the antenna capacitors in the position for minimum capacitance, and, at the same time, positions the variable inductor to an approximate setting, corresponding to the operating band selected. Homing is initiated by rotation of the BAND SELECTOR control, which also causes motor switch relay K613 to become energized, causing a proper value of output capacitance to be selected by S612. Plate voltage to the power-amplifier tube is cut off during the homing cycle, and no signal is transmitted. When the homing cycle is completed, plate voltage is applied to the power amplifier again, and the second portion of the antenna tuning cycle starts.

(2) The application of high voltage to the plate of the power-amplifier tube initiates the second portion of the tuning cycle. This accurately positions the antenna tuning capacitors and the variable inductor so that the power amplifier operates into a purely resistive load of 73 ohms. The discriminator output signals control the final positioning of the variables in the tuned circuit.

*c.* When the BAND SELECTOR control is moved to a new position, the following actions occur (fig. 1-29).

(1) Relay K613 becomes energized, which, in turn, energizes motor B603. This motor controls S612, which selects the proper combination of capacitors for the selected operating band.

(2) After the output capacitor selection has been completed, a positive voltage is applied by the homing circuits to the phasing portion of the servo amplifier. This positive voltage is converted to a square wave by chopper G901 and is then amplified by tubes V901 and V902. The output of V902 is applied to motor B1001, which rotates in a direction to reduce capacitance. Variable capacitors C1003 and C1002 are controlled by the motor and S1002 is controlled by a lost motion drive. C1003 and C1002 rotate in the homing direction and continue to rotate until S1002 is driven to a position of selecting minimum capacitance and operates S1003.

(3) At the same time that the antenna tuning capacitor is being positioned, a voltage is applied through the homing circuits to dc motor B1102. The motor then rotates to adjust variable inductor L1101, so that an approximate value of inductance is obtained for the band selected.

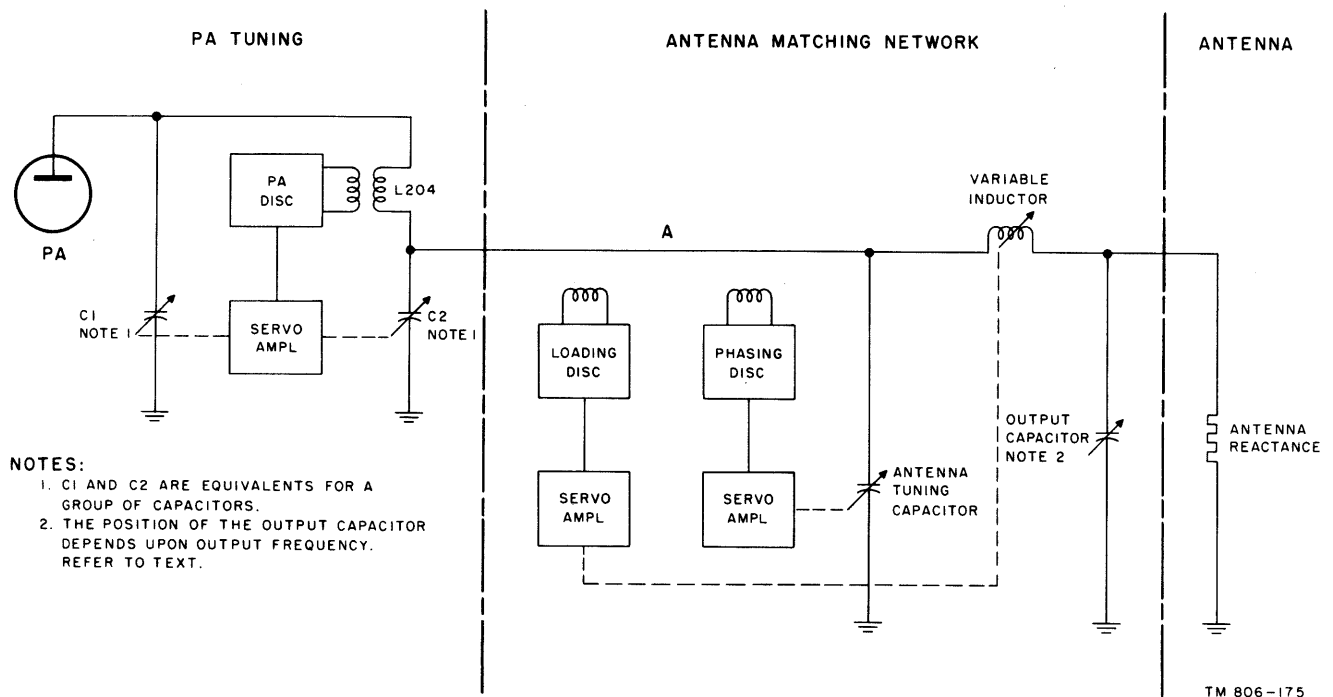

Figure 1-28. Antenna tuning system, simplified schematic.

Motor B1101 is disabled during the homing cycle.

(4) When the variable capacitor and the variable inductor reach their *home* positions, the homing circuits are disabled, and high voltage is applied to the plate of the power-amplifier tube. Rf energy is applied to the phasing and loading discriminator, which applies error voltages to the phasing and loading sections respectively of the antenna network servo amplifier.

(5) Chopper G901 converts the dc error voltages from the discriminator to the square wave voltages before they are applied to the amplifier sections. The phasing amplifier supplies voltage to motor B1001 in the antenna tuning capacitor. The loading amplifier supplies power to motor B1101 in the variable inductor.

(6) The antenna tuning capacitor motor rotates in a direction depending on the polarity of the error voltage from the discriminator. During homing, the output of the phasing discriminator is negative and the capacitance is reduced to a minimum. Then, the motor rotates to add capacitance to the transmitter output circuit. Variable capacitors C1003 and C1002 move through their range toward maximum capacitance, and the lost motion drive rotates to engage switch S1002. When capacitors C1003 and C1002 have completed 360° of rotation, S1002

finally becomes engaged and begins to move to add capacitance to the output circuit until slightly more than required capacitance is obtained. At this point, the polarity of the phasing discriminator error voltages reverses, causing motor B1001 to reverse. This leaves S1002 stationary, because of the lost motion drive, and C1003 and C1002 move in a direction to reduce capacitance, until the proper amount of capacitance is obtained. At this point, the phasing discriminator error voltage is zero, and the motor stops.

(7) During the sequence of operation described in (6) above, the loading section of the antenna network servo amplifier has a large bias imposed upon it, which reduces the sensitivity of the amplifier. As the phasing discriminator error voltage approaches zero, the bias is reduced, and full amplification of the loading discriminator error voltage occurs. The amplified signal is applied to motor B1101 and homing motor B1102 is disabled. B1101 rotates in a direction to add or remove inductance from L1101 (depending on polarity or error signal) until the inductor is properly positioned, and the error voltage is zero.

### 1-29. Homing Circuits

(figs. 1-30 and 1-31)

The homing circuits are shown in figure 1-31, with the SERVICE SELECTOR switch set to the

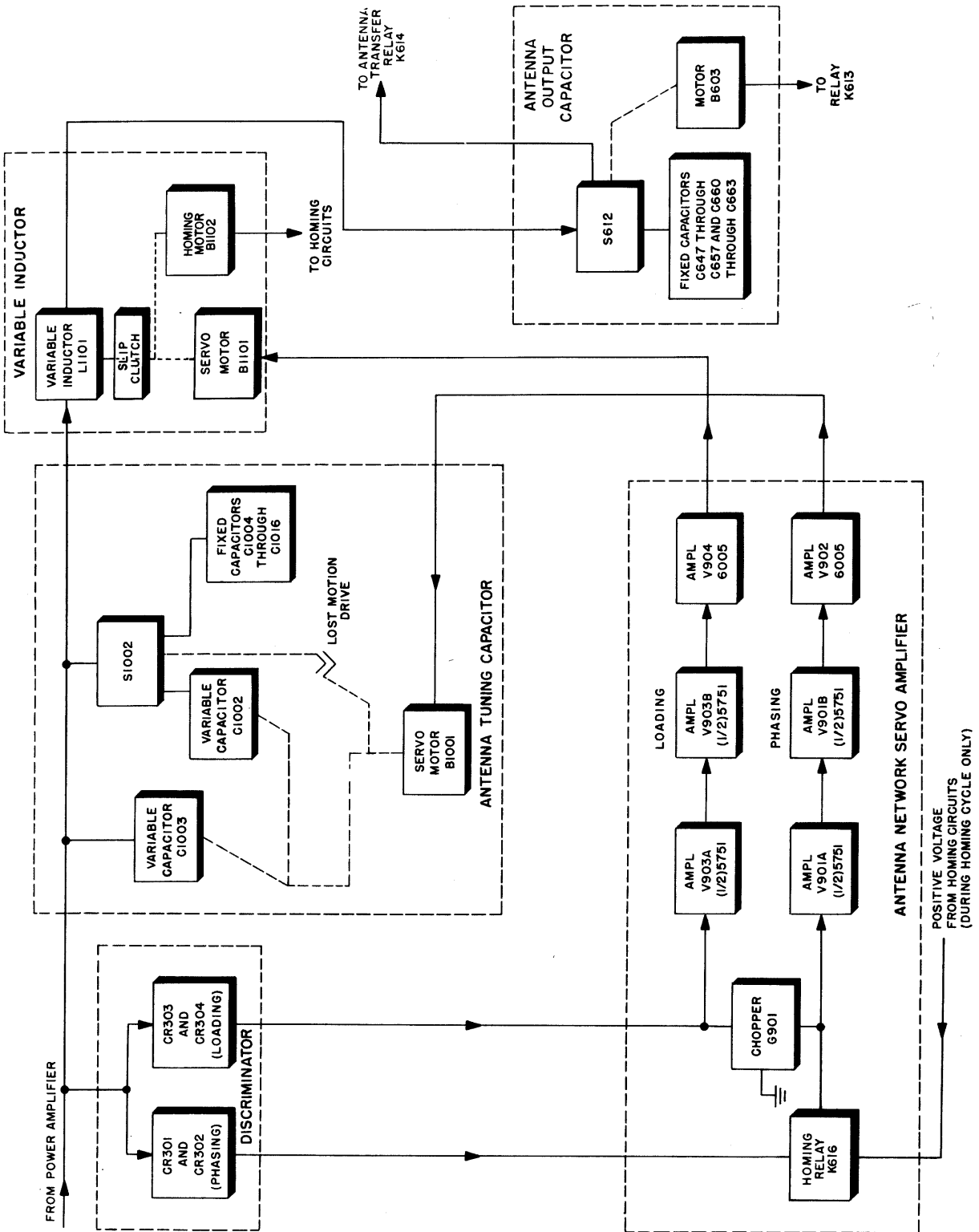

Figure 1-29. Antenna tuning system, block diagram.

VOICE/FSK position and with the antenna tuning capacitors and variable inductor L1101 properly homed for operation in the 1.5- to 1.7-mc band. The positions of the BAND SELECTOR and homing switches for this band are indicated by the solid lines. For the following discussion, it will be assumed that the BAND SELECTOR switch is moved to a new position, for operation in the 4- to 6-mc band. Final switch positions for this band are indicated by dotted lines.

*a. Initiation of Homing Cycle.* When the BAND SELECTOR control is moved to the 4- to 6-mc band, switch S101E is moved to the position indicated by the dotted lines, and the normally open contacts of cam-operated switch S203 close momentarily. This results in the following:

(1) Terminal 10 of homing relay K616 is now connected to ground through S203, contacts 4 and 7 of S1101B (front), and contacts 10 and 8 of S101E (front). S1003 presents a path to ground, through its contacts 2 and 3, when S1002 is not in its position of minimum capacitance. When terminal 10 of K616 is grounded, the relay coil is energized, and although the momentary connection to ground through S203 is broken, a new ground path is established through holding contacts 5 and 6 of K616, and the switches mentioned above. The homing relay remains energized until the ground path to contact 5 is broken. This occurs only when the antenna tuning capacitors are positioned for minimum capacitance and the variable inductor is in one of four preset positions, depending on the position of S101E (front).

(2) If the Autotune cycle has been completed, thus deenergizing relay K609, and the output capacitor circuit has completed its cycle (after which relay K613 is deenergized), 24 volts are applied through contacts 2 and 3 of K609 and contacts 4 and 3 of K613, to contact 3 of homing relay K616. With K616 energized, this voltage is fed through contact 4 to motor reversing relay K617 (contacts 2, 7, and 10). K617, when deenergized, applies 24 volts to homing motor B1102 through contacts 2 and 3. The homing motor is not energized, however, because in the VOICE/FSK position, the SERVICE SELECTOR switch does not furnish a ground for the motor until TEST KEY S603 is closed.

(3) Contact 7 of relay K616 is connected to contact 3 through voltage-dropping resistor R620. A positive voltage is applied through contact 8 (with K616 energized) to the phasing

servo-amplifier input circuit. (Contacts 8 and 9 normally feed the output of the phasing discriminator to the phasing servo amplifier.) The output of the phasing servo amplifier is applied to antenna tuning capacitor motor B1001. This servo motor does not operate at this time, since low-voltage (power control relay K602 is not energized with S606 in the VOICE position, and operating voltages for the motor are not supplied by the low-voltage dynamotor or low-voltage transistor-type power supply.

#### NOTE

The antenna tuning capacitors are shown in figure 1-31 in their home position. Normally, before homing, S1002 is at some position away from S1003, and contacts 2 and 3 of S1003 are closed.

*b. Completion of Homing Cycle.* TEST KEY S603 must be held closed by the operator to complete the homing cycle when the SERVICE SELECTOR switch is set to the VOICE/FSK position.

#### NOTE

When S606 is set to the CW position, the TEST KEY need not be pressed to complete the homing cycle.

(1) As shown in figure 1-31 if the TEST KEY is closed, contacts 1, 2, 10, and 11 of S606A, (front) are connected to ground through contact 9 of S606A (front) and contacts 10 and 9 of S603. When the SERVICE SELECTOR switch is set to CW position, contacts 1 and 11 of S606 are grounded through contact 12. This completes the circuit of homing motor B1102, through contacts 9 and 8 of reversing relay K617, and the motor rotates to position variable inductor L1101. The lv relay, K602, is also energized, and lv dynamotor D601 or low-voltage transistor-type power supply supplies operating voltages to antenna tuning capacitor motor B1001. Since a positive voltage is applied to the phasing servo amplifier (*a*(3) above), this motor rotates in a direction to decrease the capacitance of the antenna tuning capacitors.

(2) Variable inductor L1101 and switch S1101 are ganged to the shaft of homing motor B1102 through a slip clutch. Assuming that K617 is deenergized (as shown), B1102 rotates S1101 in a counterclockwise direction (toward minimum inductance) until S1101B (front) opens the ground path for contact 5 of K616 (*a*(1) above), through contact 7 of S1101B (front) and contacts 10 and 8 of S101E (front).

(a) If the antenna tuning capacitors are positioned for minimum capacitance (homed) by this time, thus opening the ground path through contacts 2 and 3 of S1003, the ground connection through the holding contacts (5 and 6) to the coil of K616 is lost. The relay then becomes deenergized, and voltage to motors B1001 and B1102 is removed. Capacitor C644 prevents arcing between contacts 3 and 4 of K616 when power is applied or removed from homing motor B1102.

(b) If the antenna tuning capacitors are not homed by this time, the ground connection to the coil of homing relay K616 is maintained through S1001 and S1003. Motor B1102 rotates S1101 past its *home* position, re-establishing the ground path to K616 through S1101B (front) and S101E. Homing motor B1102 continues to rotate S1101 in a counterclockwise direction until contacts 12 and 2 of S1101A (front) close, to provide a momentary ground path through S1101A (rear) to the coil (terminal 1) of reversing relay K617. Terminal 10 of K617 is connected to 24 volts through contacts 3 and 4 of K616, and the coil of the reversing relay is energized. This connects contact 3 of K617 to ground instead of to 24 volts, and contact 8 connects to 24 volts instead of to ground, thus reversing the polarity of the voltage applied to B1102. The motor now reverses, and S1101 rotates in a clockwise direction (toward maximum inductance). The ground path for the coil of K617 through S1101A (front) is now broken, but the holding contacts (6 and 5) of K617 maintain a path to ground through S1101A (rear). This connection is maintained until S1101 is rotated to its clockwise limit (maximum inductance), at which point the connection between contacts 2 and 4 of S1101A (rear) is broken, and the ground path to K617 is opened. K617 becomes deenergized, and the polarity of the voltage to motor B1102 is again reversed. This action continues until the antenna tuning capacitors are *homed*. Refer to (2) and (2)(a) above.

(3) During homing, variable capacitors C1002 and C1003 rotate in the *home* direction, and the lost motion drive engages S1002. Variable capacitors C1002 and C1003 continue to rotate and S1002 disconnects fixed capacitors one at a time in detent steps until the last detent position is reached and the motor stalls. At this point, contacts 2 and 3 of S1003 open, thus removing the ground path to relay K616 through the antenna tuning-capacitor switches. Motor

B1001, which is designed for *stalled operation*, remains stalled until variable inductor L1001 *homes* and relay K616 becomes deenergized, removing power from both motors.

c. *Auto Homing*. During discriminator tuning, a fault may occur which would position both the antenna tuning capacitors and the variable inductor to their minimum positions. The auto homing switch, S1101B (rear), serves to initiate a new homing cycle by making a ground connection to K616 (terminal 10) through contacts 4 and 5 of S1003 and contacts 5 and 1 of S1101B (rear).

d. *Additional Information*.

(1) Motors B1101 and B1102 are coupled through a slip clutch to the variable inductor at all times; but because of the action of the motor disabling relay, only a very little frictional drag is introduced by the servo motor (B1101) during homing. This relay, K604, removes 115-volt, 400 cps current from B1101 when the homing motor is energized. The ship clutch is adjusted to a preset torque so that the dc motor will continue to rotate when the end stop has been reached.

(2) During homing, the hv dynamotor or high-voltage transistor-type power supply is disabled by removing 24 volts from terminal 1 of the coil of hv relay K603; this deenergizes the relay. Contact 2 of the homing relay normally connects one side of the coil of K603 to 24 volts. When the homing relay is energized, contact 2 is disconnected from 24 volts.

### 1-30. Phasing and Loading Discriminator

The phasing and loading discriminator is composed of two separate circuits; the phasing discriminator, and the loading discriminator. These circuits provide a means of readjusting the capacitance and inductance of the transmitter output circuit (when a new operating frequency is selected), so that the transmitter operates into a properly match (resistive) load of 73 ohms.

a. *Phasing Discriminator* (figs. 1-28, 1-32, and 1-33). The phasing discriminator produces an error signal, the amplitude of which is proportional to the phase angle existing between the rf output voltage and current. This error signal is used to adjust the antenna tuning capacitor, to increase or decrease capacitance as required. The operation of the phasing discriminator circuit is as follows:

(1) A toroidal coil, L304B, couples a portion of the rf output  $E_p$  to the discriminator. R309 acts as a load resistor for the coil. A refer-



ence voltage  $E_c$ , is coupled to the center tap of L304B through a voltage divider composed of C306 and C302. No phase shift takes place across the voltage divider. The reference voltage,  $E_c$ , appears across R302 in parallel with R301.

(2) In a properly terminated circuit, the output of the pa is applied to a resistive circuit, consisting of the antenna tuning capacitor, the antenna output capacitor, the variable inductor, and the antenna (fig. 1-28). Therefore at resonance, the line voltage  $E_p$ , and the line rf current,  $I_p$ , at A, figure 1-28, are in phase with each other.  $I_p$  induces a secondary voltage,  $E_s$ , which lags  $I_p$  by  $90^\circ$  (A, fig. 1-33).

(3) Using the midpoint of L304B as a reference, one-half of the total voltage,  $1/2E_s$ , across L304B, is applied to crystal diode CR301 in series with the reference voltage,  $E_c$ , across R301. The other half is applied to crystal diode CR302 in series with the voltage,  $E_c$ , across R302. The addition of the voltages applied across CR301 and CR302 is shown in B, figure 1-33. Rectified voltage  $E_{R301}$  developed across R301 will be proportional to  $E_{CR301}$ . Rectified voltage  $E_{R302}$  developed across R302 will be proportional to  $E_{CR302}$ . The direction of current flow and the polarity of the developed voltages across R301 and R302 is indicated in figure 1-32. At resonance, the voltages applied to CR301 and CR302 are equal. Therefore, the rectified voltages across R301 and R302 are equal and opposite in polarity. The net result is that no error voltage is developed by the discriminator.

(4) When a mismatch occurs by switching to a lower frequency, the rf voltage and current are no longer in phase. The antenna circuit is capacitive at the lower frequency, and the rf current  $I_p$  will lead the rf voltage  $E_p$  (C, fig. 1-33). The shift in the phase of  $I_p$  causes the voltage  $E_s$  developed in L304B also to be advanced (C, fig. 1-33). The addition of the voltages applied across CR301 and CR302 is shown in figure 1-33.  $E_{CR302}$  will be larger than  $E_{CR301}$ ; therefore the rectified voltage developed across R302 is larger than the voltage developed across R301. The net result is a positive voltage developed by the discriminator.

(5) The voltage relationships developed by an inductive circuit in which the rf current,  $I_p$ , lags the voltage  $E_p$ , are shown in E and F, figure 1-33. The addition of the voltages indicates the development of a negative voltage by the discriminator.

(6) The dc output voltage of the phasing discriminator is fed through the rf filter circuit composed of C301 and R307, to an attenuating

circuit which varies the amplitude of the voltage with respect to frequency. This is necessary because the output of the discriminator varies approximately 16 db over the entire frequency range of the transmitter. Switch S614B (front) is controlled by output capacitor motor B603, so that when output capacitance selection is made for a particular operating frequency, the attenuating circuit is also adjusted. In figure 1-32, the switch is shown positioned for transmitter band 1 (1.5 to 1.7 mc). For bands 1, 2, and 3 (1.5 to 2.4 mc), the discriminator output is fed, without attenuation, through contacts 1 and 8 of S614B (front) and the normally closed contacts of homing relay K616, to the antenna network servo amplifier. For band 4 (2.4 to 3 mc), the voltage is fed through contacts 1 and 4 of the switch, and no attenuation takes place. For bands 5, 6, 7, 8, and 9 (3 to 16 mc), the discriminator voltage is fed through voltage dropping resistor R606, and through contacts 5 and 4 of the switch, to the contacts of the homing relay. For band 10 (16 to 20 mc), the voltage is fed through R606 and contacts 5 and 8 of the switch to relay K616. Capacitor C621 is connected across R606 to remove ripple from the dc voltage.

(7) The error voltage is used then to drive the servo which varies the antenna tuning capacitor until  $I_p$  and  $E_p$  are in phase (para 1-31).

*b. Loading Discriminator* (figs. 1-28 and 1-34). The relationship between voltage and current amplitudes of the transmitter output signal can be expressed by the ratio of  $Z = E/I$ . From this formula, if the load impedance  $Z$  increases, the load current  $I$  decreases, and therefore the rf plate output voltage  $E$  must increase. Physically, an increase in the load impedance  $Z$  causes a decrease in  $I$ . This results in a smaller  $I_r$  drop across the internal plate resistance of the power amplifier, and this increases the amplitude of the rf output. Similarly, if the load impedance decreases, the current will increase, the  $IR$  internal plate resistance drop will increase, and the rf output voltage will decrease. The loading discriminator interprets these relative changes in rf voltage and current as dc voltages, the polarities of which are determined by the direction of the change.

(1) L304A is a coil wound on the same iron toroid form used for the phasing discriminator. The coil is inductively coupled to the rf output circuit. The voltage induced across L304A is proportional in amplitude to the rf line current. This induced voltage is applied to crystal rectifier CR 304 through current limiting resis-

tors R308 and R310. The rectifier causes a dc potential to appear across R304, which is proportional to the voltage across L304A (electron-current flow is indicated by the arrows in figure 1-34). C307 is a compensating capacitor that permits the voltage developed across R304 to remain constant regardless of frequency. At the low frequencies, C307 acts as open circuit and has little effect. At the higher frequencies it draws sufficient current so that the voltage across R304 remains almost constant as the frequency changes. C305 and R303 form an RC voltage divider, wherein the reactance of C305 is always at least 10 times the resistance of R303. This produces an rf voltage across R303 and C308 which is directly proportional to frequency. This rf voltage is impressed upon rectifier CR303, which, in turn, causes a dc potential to appear across R305. Since C305 is variable, it can be adjusted to produce a dc voltage across R305 exactly equal in amplitude and opposite in polarity to the dc voltage across R304 when the load impedance is 73 ohms. When this adjustment has been made, there will be no dc potential present at the discriminator output. C308 is a frequency compensating capacitor which permits the voltage developed across R305 to remain constant. At the lower frequencies C308 has little effect. At the higher frequencies, C308 reduces the voltage applied across R303 and thereby reduces the voltage developed across R305.

(2) When the magnitude of the load impedance is changed from 73 ohms, a dc potential will be present at the discriminator output. If the impedance is raised, the line voltage will increase and the line current will decrease. This results in an increase in the voltage across R305 and a decrease in the voltage across R304. Since these voltages are added back to back, the net output voltage is negative. If the load impedance is reduced below 73 ohms, the line current will increase and the line voltage will decrease; this results in a larger dc potential across R304 than that across R305, and the net output voltage is positive. In this manner, the dc output voltage of the loading discriminator indicates whether the magnitude of the rf impedance is above or below 73 ohms. This error voltage is then used to adjust the variable inductor until the rf impedance is 73 ohms.

(3) The dc output voltage of the loading discriminator is fed through an rf filter circuit composed of C303, C304, and R306 to an attenuating circuit. This circuit is necessary be-

cause the amplitude of the error voltage varies with frequency. For the first six transmitter bands (1.5 to 9 mc), the error voltage is fed through contacts 6 and 3 (or 7) of switch S614B (rear) to the antenna network servo amplifier, without attenuation. For the last three bands (9 to 20 mc), the voltage is fed through the voltage divider composed of R608 and R609 and contacts 6 and 2 (and 7 or 3) of the switch to the antenna network servo amplifier.

(4) By using a variable capacitor for C305, compensation for variation in circuit constants can be provided. However, under no circumstances should C305 be adjusted in the field. The adjustment of C305 can be done only at depots where sufficient test equipment is available.

### 1-31. Antenna Network Servo Amplifier

#### a. Input Circuits (fig. 1-35).

(1) *Phasing section.* The output of the phasing discriminator is applied to the input circuit of the phasing servo amplifier. The filter composed of C901, R901, and C902 removes audio-frequency components which may be present in the error signal when the transmitter is modulated. The RC network composed of C903, R902, and R903 serves to stabilize the operation of the servo amplifier.

(2) *Loading section.* The output of the loading discriminator is applied to the input circuit of the loading servo amplifier. The filter circuit of this section is composed of C911, R915 and C912. The stabilizing RC circuit consists of C914 and R916.

(3) *Chopper G901.* Exciting voltage for the chopper is obtained from the 115-volt, 400-cps dynamotor. C921, C922, and C923 compensate for the slightly inductive loads presented to the 400-cps generator. R929 and C924 provide a 25° phase shift in voltage, which, added to the 65° phase shift obtained in the chopper, provides the 90° phase shift necessary for rotation of the servo motors (para 1-48). Stepdown transformer T901 furnished 6.3 volts ac to the coil of G901, which causes the grid input circuits of the phasing and loading amplifiers to be grounded alternately at a rate of 400 cps. This results in a 400-cps, squarewave voltage, proportional in amplitude to the dc error voltages applied to the input of each amplifier. Transformer T901 also furnishes 400-cps exciting voltage to power-amplifier chopper G201, and side-tone voltage to

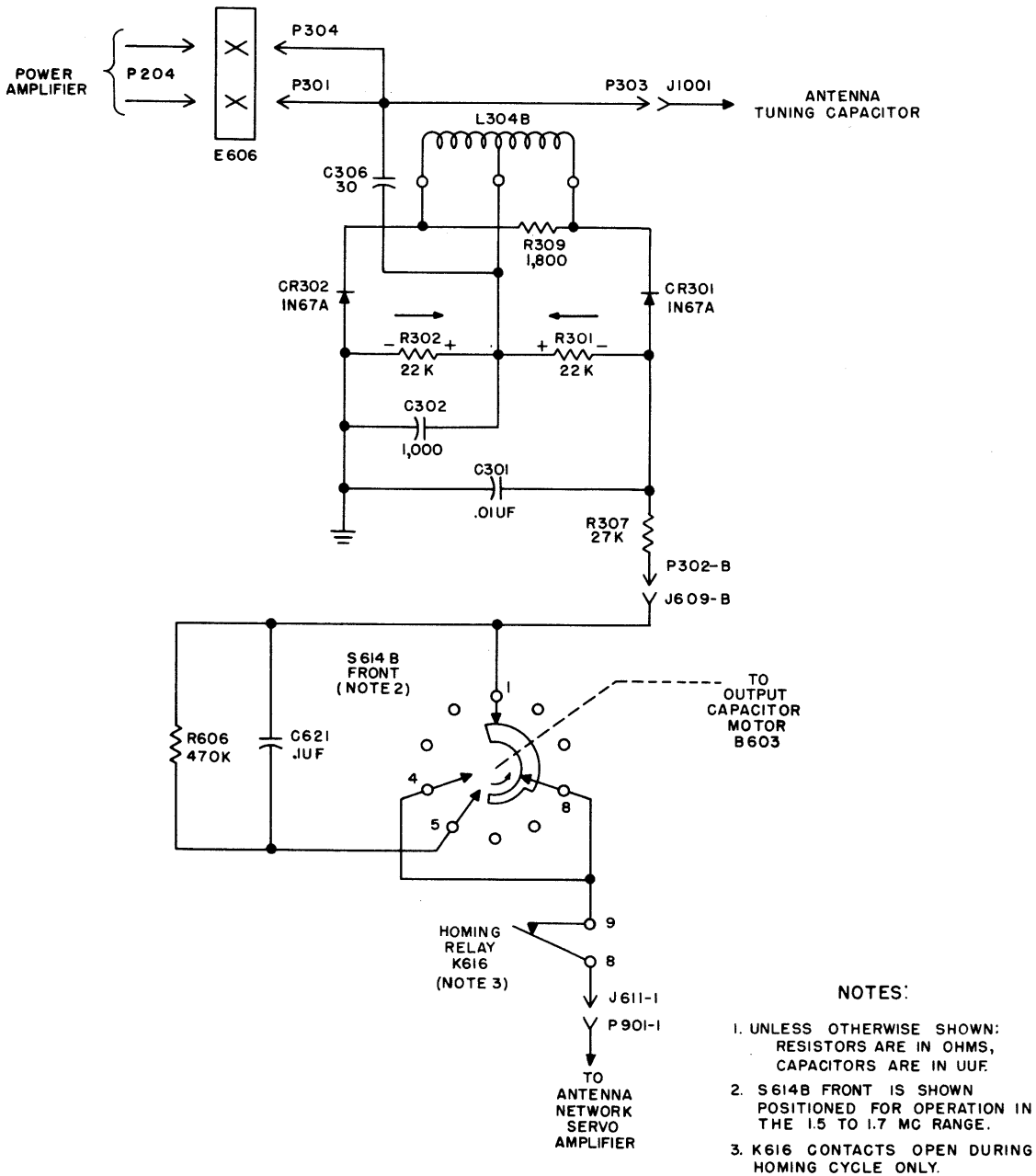

- NOTES:
1. UNLESS OTHERWISE SHOWN:  
RESISTORS ARE IN OHMS,  
CAPACITORS ARE IN UUF.
  2. S614B FRONT IS SHOWN  
POSITIONED FOR OPERATION IN  
THE 1.5 TO 1.7 MC RANGE.
  3. K616 CONTACTS OPEN DURING  
HOMING CYCLE ONLY.

TM 806-44

Figure 1-32. Phasing discriminator, functional diagram.

modulator sidetone amplifier V403A (para 1-26).

(4) *Transistorized chopper G901* (fig. 1-36). In Radio Transmitter T-195A/GRC-19, a transistorized chopper replaces mechanical chopper G901. Transistorized chopper G901 consists of a PNP type transistor (2N1024), a NPN type transistor (2N470), resistor R937 and R938, and capacitor C925. The transistorized chopper is directly interchangeable with mechanical chopper G901.

(5) *Transistorized chopper circuit analysis* (fig. 1-36). The phasing-error voltage (from C903, R902, R903) is applied through pin 6 to the emitter (e) of PNP transistor Q900. The collector is connected through pin 7 to ground. Emitter-to-collector resistance is alternately reduced and increased by the changing polarity of 400-cps switching voltage (from T901-5) applied to the base (b<sub>1</sub>) of the transistor through resistors R937 and R938. Resistance is decreased by the negative alternation and increased by the

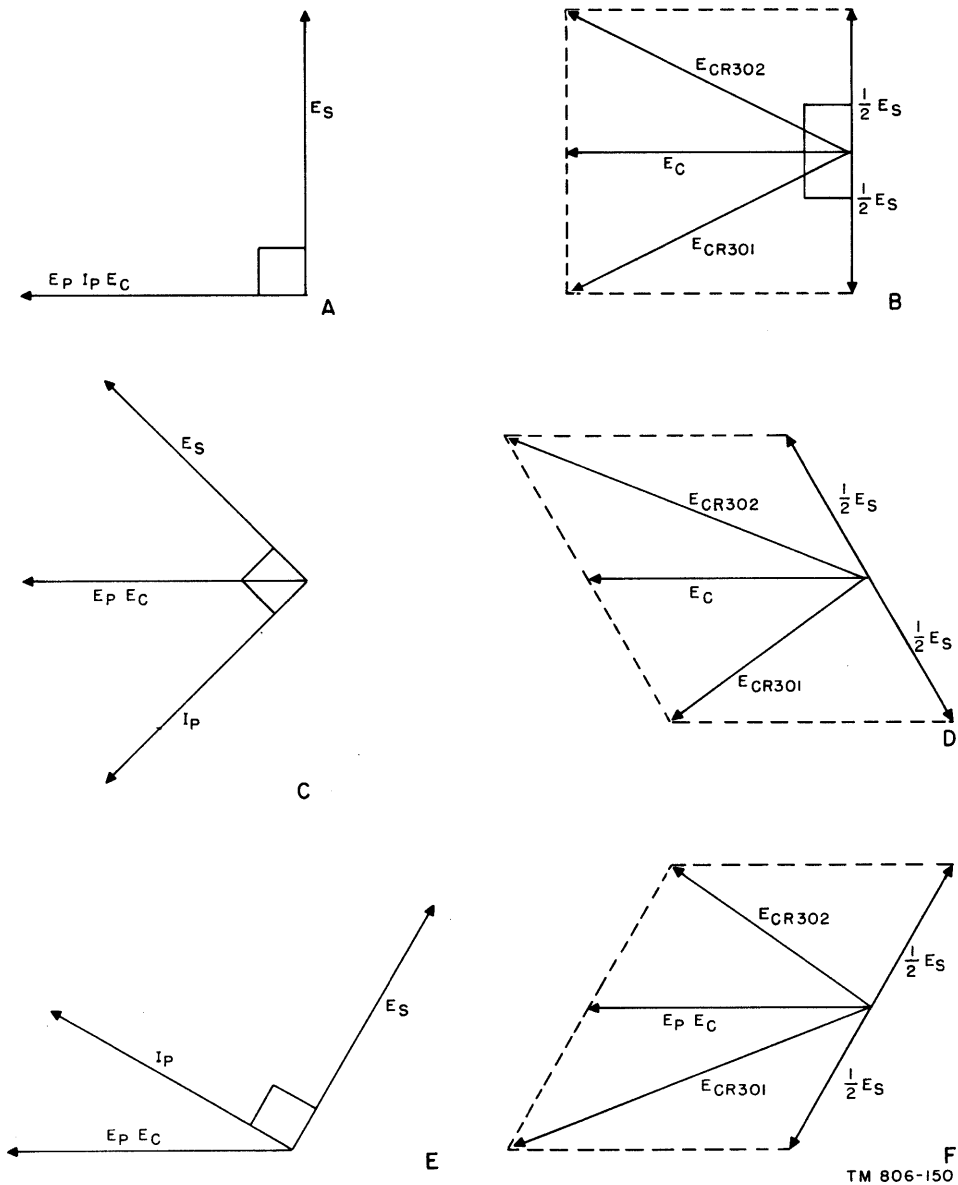

Figure 1-33. Phasing discriminator, voltage relationships.

positive alternation. This switching action of the transistor simulates the switching action of the contact points on the vibrator type chopper.

(a) Resistor R938 and capacitor C925 shifts the phase of the 400-cps voltage applied to the bases of the transistors by approximately  $65^\circ$ . Isolating resistor R937 prevents loading of the phase-shift circuit. Negative alternations of the 400-cycle switching voltage applied to the base of the transistors cause the transistors to alternately provide a low resistance path to ground for the dc phasing-error voltage.

(b) The loading-error voltage (from C914, R916) is applied through pin 1 to the collector (c<sub>1</sub>) of NPN transistor Q901 and appears

across collector and emitter of the transistor. The emitter (e<sub>1</sub>) is connected to ground through pins 2, 3, and 5. The switching voltage, applied to the base (b<sub>1</sub>) of NPN transistor Q901, alternately changes the resistance between the collector and the emitter of the transistor from low to high values. The positive alternations of the switching voltage cause the transistor to short the loading-error voltage. Transistor Q900 provides a low resistance path during the positive alternation. This switching action is similar to the switching action of the vibrator type chopper.

b. *Amplifying Circuits* (fig. 1-37). Because the phasing and loading amplifying circuits are

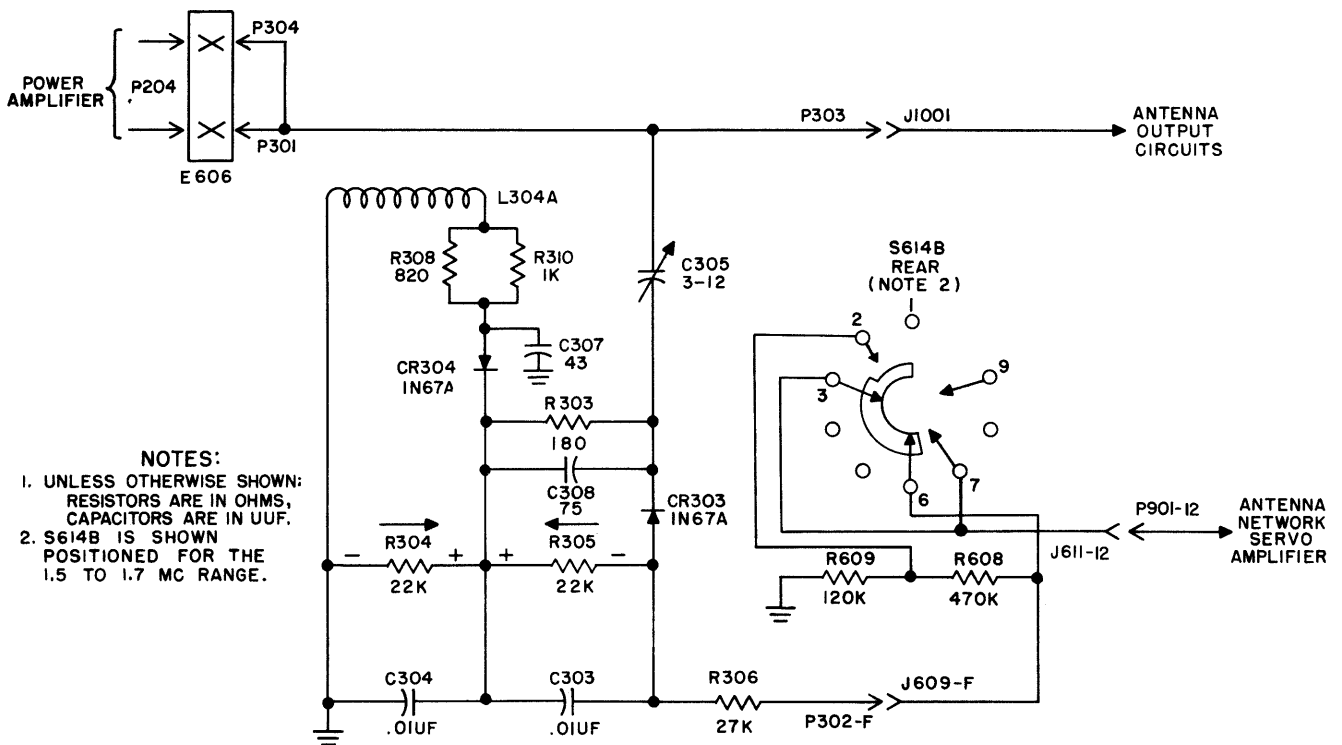

TM 806-45

Figure 1-34. Loading discriminator, functional diagram.

almost identical, the following description applies to both circuits. Each circuit converts the 400-cps square wave voltage to 400-cps sine wave voltage, of the proper phase and amplitude, for application to its associated servo motor.

(1) The 400-cps square wave voltage, proportional in amplitude to the dc error signal, is coupled by dc blocking capacitor C904 to the input grid of phasing amplifier V901A. This stage utilizes one-half of a miniature dual-triode tube, type 5751. An rf filter, consisting of R904 and C905, reduces the magnitude of the high frequency components of the square wave voltages which would upset the operation of the servo amplifier if applied to the control grid of V901A. Bias voltage for the tube is developed across grid resistor R905.

(2) V901A amplifies the modified square wave voltage from the chopper and applies this amplified voltage to plate load resistor R906. Plate supply voltage is decoupled by R908 and C918. Blocking capacitor C909 couples the audio output of V901A to the control grid of second phasing amplifier V901B. R907 and R909 serve as grid leak and cathode bias resistors, respectively, for this tube. The decoupling network consists of R913 and C908. R910 is the plate

load resistor for V901B. Coupling capacitor C907 and grid resistor R911 comprise the input circuit of third phasing amplifier V902. This tube is a miniature pentode, type 600/6AQ5W. Cathode bias is generated across R912 to establish the proper operating point for the tube. A potential of +250 volts is applied to R930, which feeds voltage to the screen grid of V902.

**NOTE**

In the following explanation, it is assumed that grid resistor R923 of loading amplifier V903B is not connected to ground.

*c. Output Circuits (fig. 1-38).*

(1) The phasing and loading discriminators operate the antenna tuning capacitor and the variable inductor until the desired output conditions are obtained. Since adjustment of either the variable inductor or the antenna tuning capacitor will require a change in the other, some means must be found to prevent the possibility of constant adjustment and readjustment during the antenna tuning process. To do this, the sensitivity of the loading amplifier is reduced while the phasing amplifier adjusts the antenna tuning capacitor.

(2) A portion of the phasing amplifier output is coupled through C915 to the junction of C915 and R920. Positive portions of the ac signal are bypassed to ground through CR901 and R917. Negative portions of the ac signal are applied across K901, CR902, and R917. As a result of this action, a pulsating negative voltage appears at the junction of R920, CR901, and C915. The filtering action of C920 and R922 converts this voltage into a negative dc voltage which is applied to the grid of V903. This increased negative bias reduces the sensitivity of the loading amplifier. Unless a large error is present in the loading amplifier, the adjustment of the variable inductor will not be changed. When the phasing amplifier has completed the adjustment of the antenna tuning capacitor, the phasing error voltage is reduced to zero, the negative bias is removed from V903, and the loading amplifier is free to act.

(3) When the antenna tuning capacitor is at its maximum or minimum position, the loading amplifier functions normally. This is accomplished by grounding the bias voltage through S1003 or S001.

(4) Voltage from the phasing and loading amplifier is applied to the coil of K901 through C915 and C913. Rectification of the signals is accomplished through CR901 and CR902. The result of this rectification is that only a pulsating dc flows through the coil of K901, and, because of the polarization of CR901 and CR902, this current will flow in only one direction. Therefore, an error voltage appearing in the phasing or loading amplifier will open the contacts of K901 and prevent the TUNING INDICATOR from lighting. Whenever the key is depressed (activating K601) and no error voltage appears in the servos (indicating correct antenna tuning), the contacts of K901 will close and the TUNING INDICATOR will light.

**1-32. Output Capacitor**  
(fig. 1-39)

The purpose of the output capacitor is to decrease the high capacitive reactance of the antenna at the lower operating frequencies of the transmitter, and to increase the capacitive reactance of the antenna at the higher frequencies.

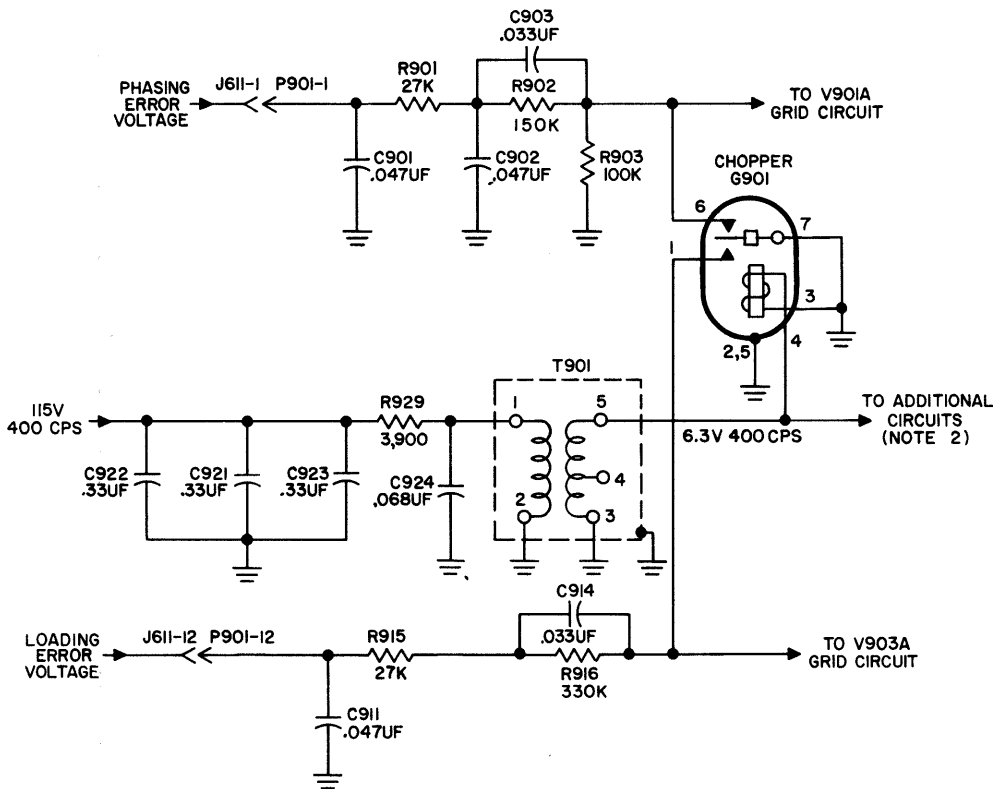

- NOTES:**
1. UNLESS OTHERWISE SHOWN: RESISTORS ARE IN OHMS.
  2. SEE 115V 400 CPS VOLTAGE DISTRIBUTION.
  3. FOR MODELS OF SERVO AMPLIFIER SUB-CHASSIS LABELED MOD 6A AND HIGHER, THE VALUE OF R916 IS 560K.

Figure 1-35. Antenna network servo amplifier input circuits, functional diagram.

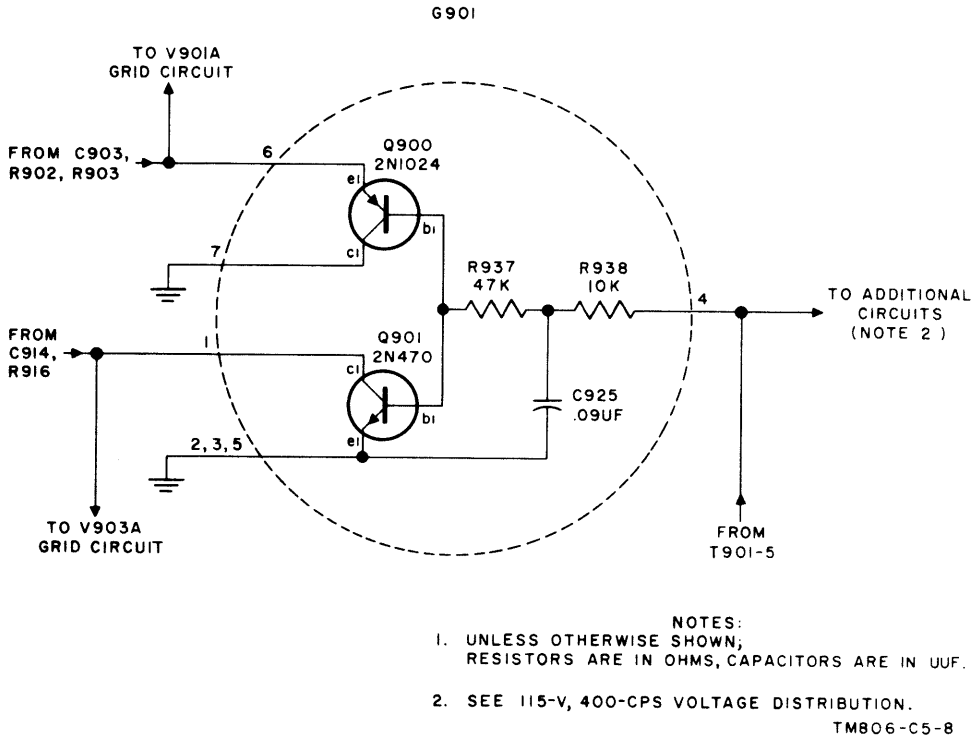

Figure 1-36. Antenna network servo amplifier transistorized chopper, schematic diagram.

At the center frequencies, the antenna tuning capacitor and the variable inductor are sufficient for phasing and loading of the antenna.

a. The proper output capacitor circuit is selected by S612A and S612B. These switch sections are controlled by output capacitor motor B603, which, in turn, is controlled by open-circuit seeking switches S' 14A (front and rear) and S101C (front and rear).

b. When the BAND SELECTOR is moved to a new band setting, a ground connection is established through S101C and S614A to the coil of motor switch relay K613. This energizes the relay that connects R605 through contacts 2 and 3 to contacts 2 and 11 of the SERVICE SELECTOR switch (S606A front). If S606 is in the CW position, contact 11 is connected to ground. If S606 is in the VOICE/FSK position, TEST KEY S603 must be closed to ground the circuit. Twenty-four volts is applied through contacts 2 and 3 of Autotune muting relay K609 to the positive side of B603, so that during the Autotune cycle, the circuit of B603 is disabled. If the Autotune cycle has been completed and the

ground connection through S606 has been made, the motor will rotate, and thus cause the rotation of S612 and S614A.

c. Switches S612 and S614A each have 10 positions. When S612 is rotated, it selects the proper output circuit, depending on the position of the switch when the motor rotation is stopped. When S614A is rotated, it seeks to break the ground path present between S101C and terminal 5 of K613. The ground path can be broken in only one position of S614A for a given position of S101C. In figure 49, S101C is set to the 1.5- to 1.7-mc range, and S614A is shown properly positioned to break the ground path to K613. In all other positions of S614A the ground path is maintained. If S101C were moved, motor B603 would be energized and S614A would be rotated until the ground path was again broken. When the ground path to K613 is broken, the relay is deenergized, and contact 3 is connected to the 24-volt supply, through contact 4, instead of to ground. This short circuits the motor terminals to the 24-volt supply and provides a dynamic brake on motor B603 to prevent overtravel.

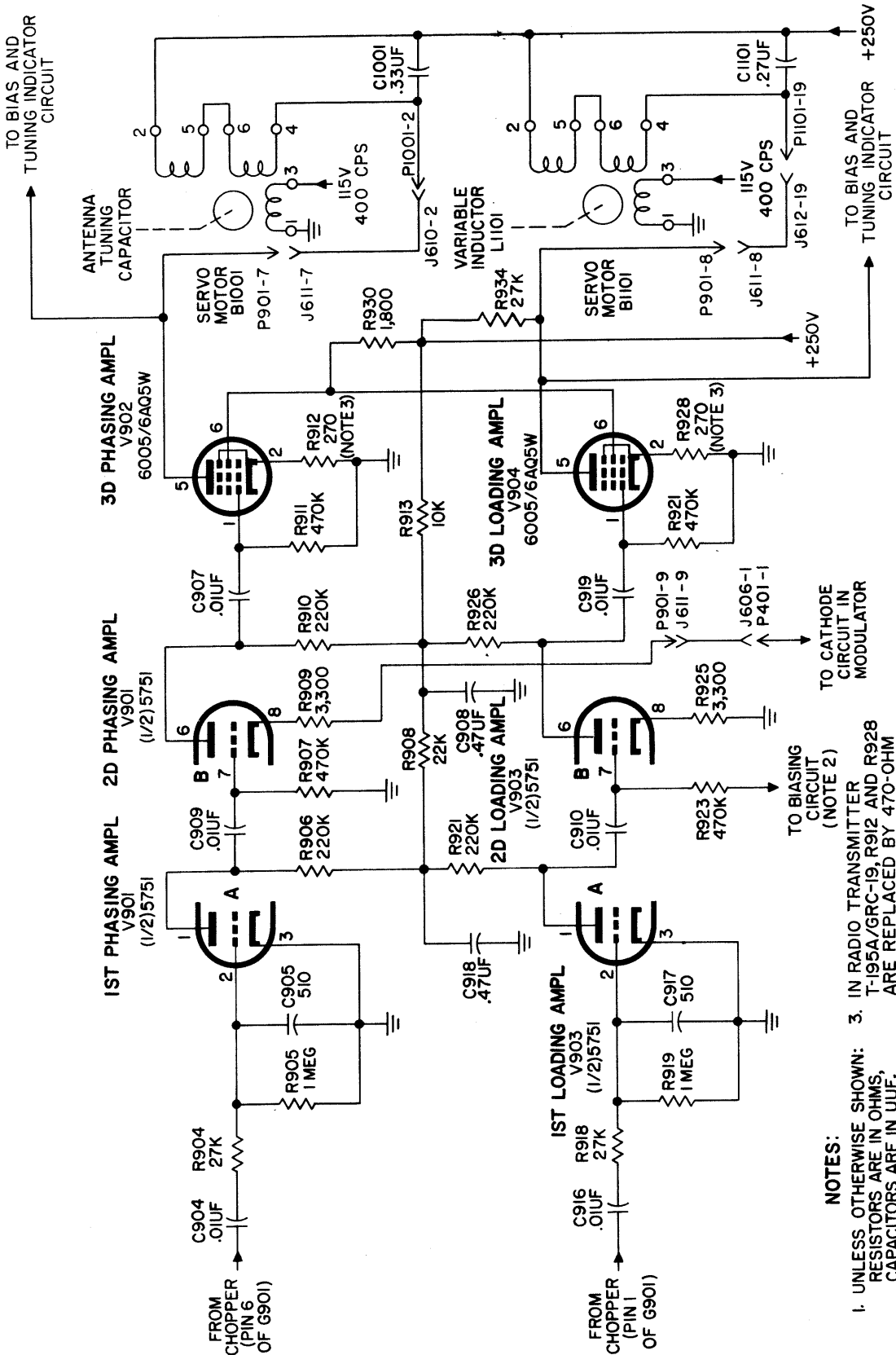

**NOTES:**

1. UNLESS OTHERWISE SHOWN: RESISTORS ARE IN OHMS, CAPACITORS ARE IN UUF.
2. SEE ANTENNA NETWORK SERVO AMPL BIAS AND TUNING INDICATOR CIRCUIT.
3. IN RADIO TRANSMITTER T-195A/GRC-19, R912 AND R928 ARE REPLACED BY 470-OHM RESISTORS; R930 IS REPLACED WITH A JUMPER WIRE.

Figure 1-37. Antenna network servo amplifier, amplifying circuits functional diagram.



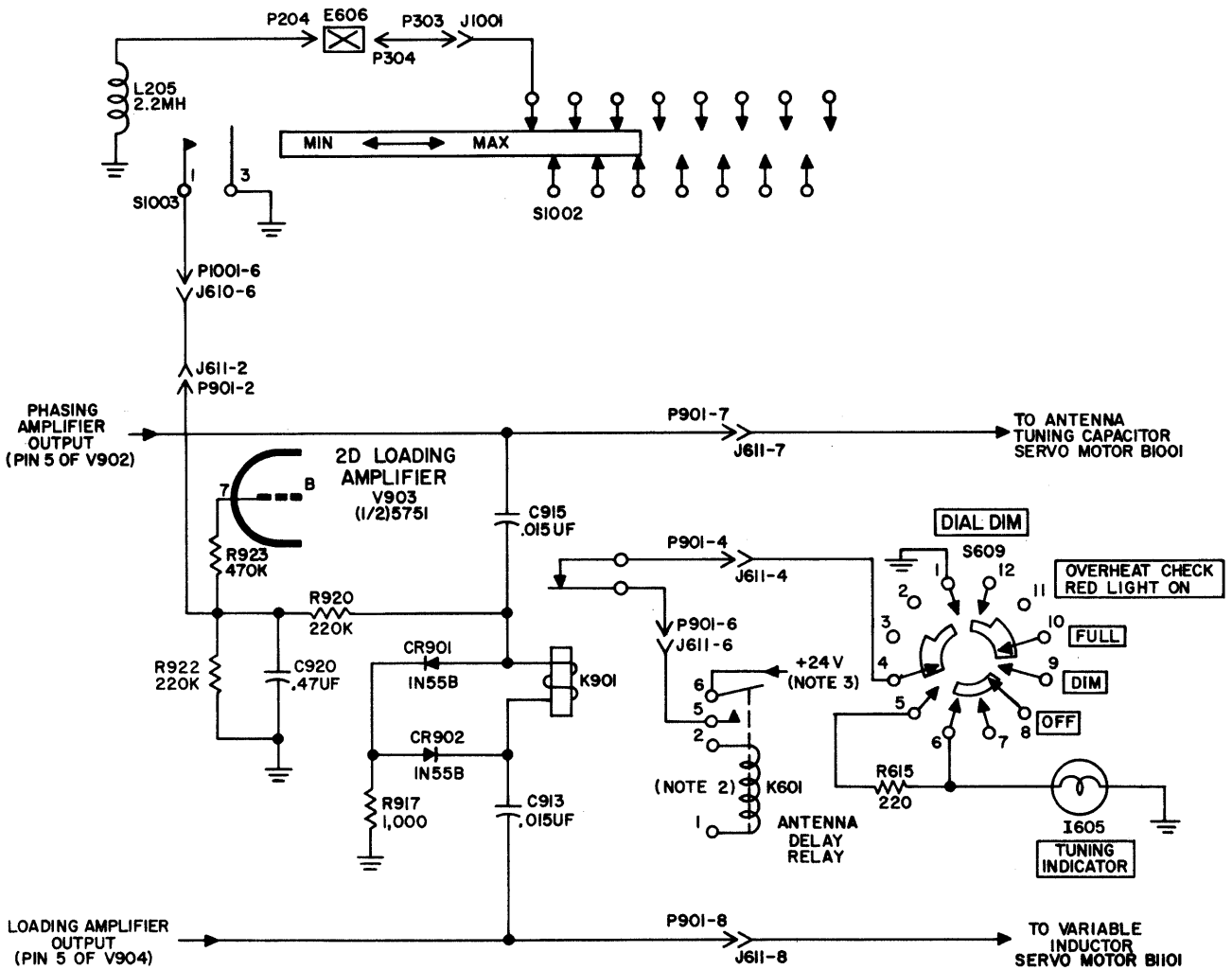

**NOTES:**

1. UNLESS OTHERWISE SHOWN:  
RESISTORS ARE IN OHMS,  
CAPACITORS ARE IN UUF.
2. K601 IS ENERGIZED BY KEYING RELAY K605.
3. +24V IS SUPPLIED WHEN HV RELAY IS ENERGIZED.

TM 806-48

Figure 1-38. Antenna network servo amplifier, output circuits, functional diagram.



**Section VIII. ANTENNA SWITCHING AND KEYING CIRCUITS**

**1-33. General**

The antenna switching and keying circuits are closely related and comprise one functional circuit. The purpose of this functional circuit is to provide the following effects:

- a. Blocked-grid keying for cw transmission.
- b. Power-amplifier protection between transmissions.
- c. Antenna switching between transmitter and receiver.
- d. Receiver disabling during transmission.
- e. Keying control.
  - (1) In normal and duplex operation, by an external key or microphone.
  - (2) In relay operation, by the receiver control circuits.
- f. A means of monitoring the transmitted signals.
- g. Continuous connection of transmitter to antenna during continuous keying, thus preventing distortion of keying waveform and damage to relays because of excessive operation.

**1-34. Flow Chart**  
(fig. 1-40)

The flow chart of figure 1-40 shows the sequence of events when the key or microphone switch is closed. When the key or microphone switch is opened, an opposite set of conditions is set up in each block of the flow chart, with one exception: antenna delay tube V403 continues to conduct for a short period of time after the keying relay is deenergized. Therefore, during continuous keying, the circuits that are actuated by the conduction of V403, remain in a steady state of operation. The transmitted carrier signal is interrupted, however, since rf excitation is removed and the keying relay interrupts the negative bias applied to V202. This tube then conducts and drops the screen voltage on V201 (para 1-17).

**1-35. Circuit Analysis**  
(fig. 1-41)

**NOTE**

In Radio Transmitter T-194B/GRC-19 on Order No. 4096-PP-60, unsealed receiver antenna relay K615 (used in the T-195/GRC-19, T-195A/GRC-19, and early T-195B/GRC-19) is replaced with hermetically sealed relay K615. Termi-

nal numbers of the sealed relay corresponding to the contact numbers of the unsealed relay are given in the chart below.

<i>Radio Transmitter T-195/GRC-19 T-195A/GRC-19, and early T-195B/GRC-19 K615 contact No.</i>	<i>Radio Transmitter T-195B/GRC-19 (Order No. 4096-PP- 60) K615 terminal No.</i>
1	1
2	10
3	3
4	2
5	5
6	4
7	7
8	8
9	9

In the following discussion, the application and removal of operating voltages during keying is not included (para 1-42).

a. *Keying Relay Control.* The coil of keying relay K605 is energized by connecting one side of its coil to ground. This can be accomplished by the following circuits:

(1) When TEST KEY S603 is operated, it connects K605 to ground through contacts 10 and 9 of S603 and current-limiting resistor R621.

(2) When the microphone switch at the transmitter, receiver, or remote location is closed, it connects K605 to ground through R621, Z601, and one of the receptacles mounted on the front panel of the transmitter.

(3) When S602 is in the RELAY position, K605 is connected to ground through R621; contacts 5 and 6 of S602; the rf filter composed of C612, L621, and C639; one of the receptacles mounted on the front panel of the transmitter; and the keying circuit located in the receiver.

b. *Sidetone Control.* The sidetone amplifier, V403A, is normally biased to the cutoff point by a negative voltage which is applied through R119, R406, and R436 to its control grid. When relay K605 is energized, the biasing voltage is grounded through R119 and contacts 7 and 6 of the relay. This removes the negative bias and allows the sidetone amplifier to operate (para 1-26). Capacitor C404 provides rf filtering for the grid circuit of V403A.

c. *Blocked-Grid Keying.* The first multiplier tube, V101, the driver tube, V104, and the pre-amplifier tube, V401A, are normally biased to the cutoff point by the negative voltage applied to their respective grid circuits through R119. Capacitor C134 serves as an rf filter for this

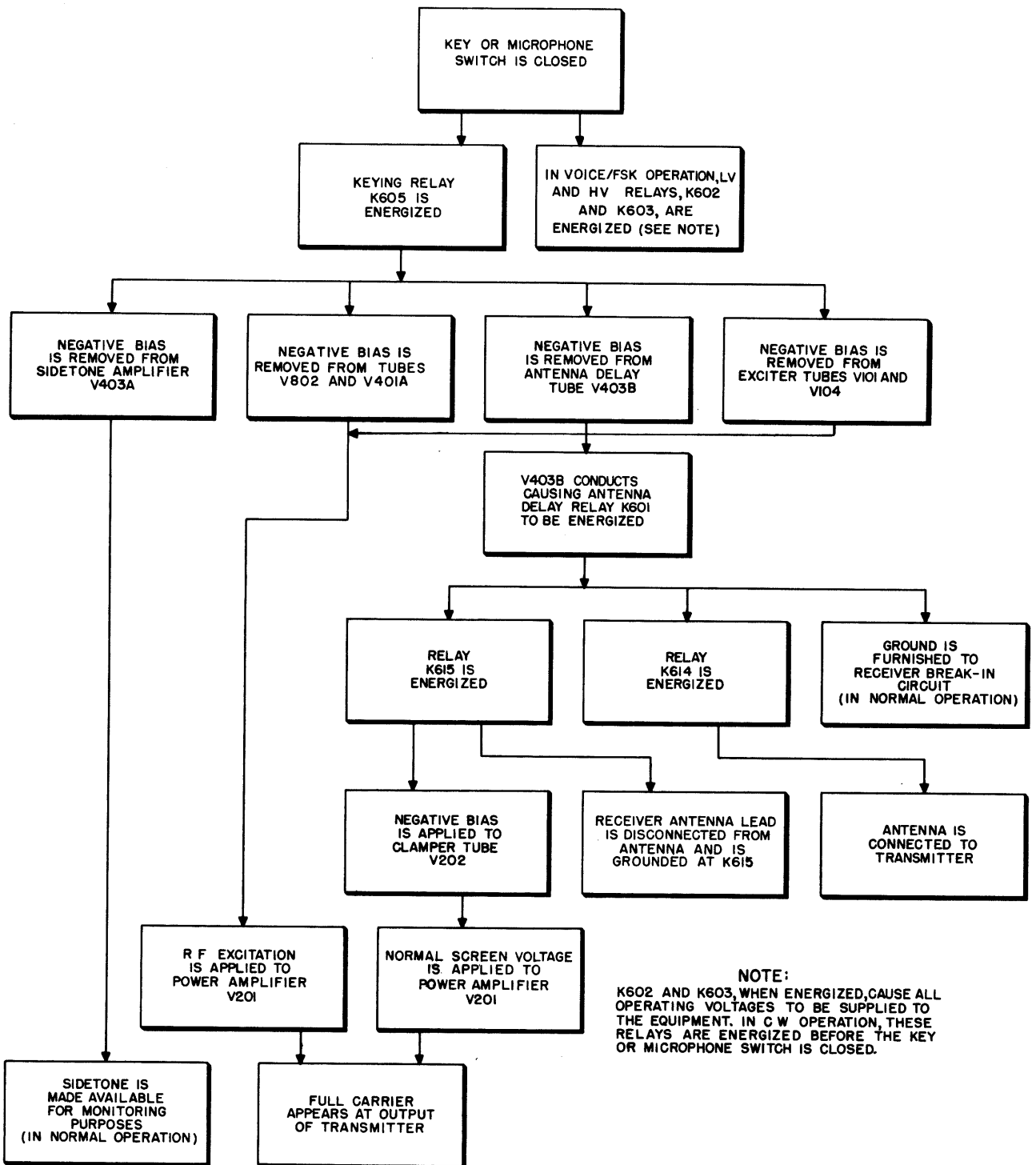

TM 806-50

Figure 1-40. Antenna switching and keying, flow chart.

voltage, which is fed to the control grid of V101 through R120 and R101, to the control grid of V104 through R114, and to the control grid of V401A through R405 and R410. Capacitor C102 serves as an rf filter for the grid circuit of V101. When the keying relay is energized, the biasing

voltage is grounded through R119 and contacts 7 and 6 of the relay. This removes the negative bias from V101, V104, and V401A; the exciter then functions to provide rf excitation to the grid of power amplifier V201, and the modulator supplies audio signals to the plate circuit of

V201. (See para 1-10, 1-11, and 1-22 for complete tube circuits). The buffer amplifier, V802, is also biased to cutoff between transmissions, by the suppressor grid connection to the biasing circuit of V403 (below). (See para 1-7 for complete tube circuit.)

*d. Antenna Delay.*

(1) A negative bias is normally applied to the control grid of antenna delay tube V403B through the large resistance of R448, and the tube does not conduct. When the keying relay is energized, the control grid of V403B is connected to ground through current-limiting resistor R453 and contacts 4 and 5 of K605. This causes the grid to become less negative, and the tube conducts through plate resistor R626 and the coil of antenna delay relay K601 to the +250-volt supply. Current flow through the coil of K601 energizes the relay, and the following occurs:

(a) If S602 is set to the NORMAL position, the receiver break-in circuit is connected to ground through contacts 9 and 10 of S602 and contacts 4 and 3 of K601.

(b) A potential of +24 volts is applied through contacts 5 and 6 of K601 to R610 and the coil of K615, and through contacts 4 and 5 of K615 to K614. When K615 operates, the high starting current to K614 is broken, and the voltage is fed to K614 through R610 only. This prevents too high a current flow through the coil of K614. At this time, both relays are energized.

1. When K614 is energized, WHIP ANTENNA receptacle J615 or 50 OHMS OUTPUT receptacle J614 is connected to the transmitter output circuits, and RECEIVER ANTENNA receptacle J616 is disconnected.

2. When K615 is energized, RECEIVER ANTENNA receptacle J616 is grounded.

3. A negative bias is applied through K615, S203, and K202 to the control grid of clamper tube V202. Cam switch S203 prevents application of negative bias to the clamper during band switching, and K202 removes the bias when current through the power-amplifier tube becomes too great (para 1-17b). The bias voltage drives the clamper tube to cutoff, which increases the screen voltage applied to the pa tube (para 1-17). Resistor R229 is the grid resistor

and, with C208, controls waveshaping (para 1-17b).

(2) When the key or microphone switch is closed and antenna delay tube V403B is conducting, C424 charges to the value of voltage applied to the control grid. When the key or microphone switch is opened, thus deenergizing K605, R453 is no longer connected to ground, and the voltage applied to the grid of V403B becomes more negative. Capacitor C424, however, requires time to charge through R448 and draws current until fully charged. This means that the grid bias does not cut off V403B immediately after K605 is deenergized; the tube will continue to conduct for the amount of time C424 requires to become fully charged. Relays K601, K614, and K615 remain energized while the tube is conducting, and if the keying relay is energized again before C424 becomes fully charged, the relays will remain energized.

*e. Power-Amplifier Protection.* When keying relay K605 is deenergized, negative bias is removed from the control grid of clamper tube V202. The tube then operates to reduce the screen voltage to power-amplifier tube V201. This prevents excessive current from being drawn through V201 which would damage the tube or its associated circuits (para 1-17).

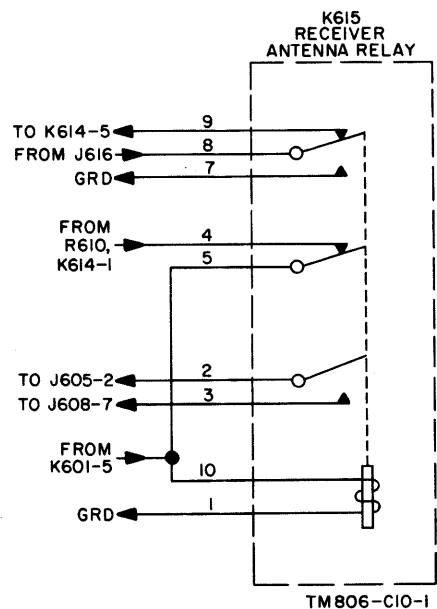

Figure 1-42. Hermetically sealed receiver antenna relay K615 (used in T-195B/GRC-19 on Order No. 4096-PP-60) schematic diagram.

**Section IX. AUTOTUNE SYSTEM**

**1-36. General**

The operating frequencies of Radio Transmitter T-195/GRC-19 are determined by the position of tuning cores and band switches. These tuning devices are controlled by an electromechanical system which provides for both automatic and manual tuning. Eight automatically tuned channels are available, each of which is preset manually to a desired channel frequency. When a preset channel is selected, the Autotune system adjusts the tuning cores and band switches to provide the desired operating frequency. One of the eight Autotune channels is designated for manual tuning, but may be preset for automatic tuning.

<i>Radio Transmitter T-195/GRC-19 K610 contact No.</i>	<i>Radio transmitters T-195A/GRC-19 and early T-195B/GRC-19 K610 terminal No.</i>	<i>Radio Transmitter T-195B/GRC-19 (Order No. 4096 PP 60) K610 terminal No.</i>
1	1	1
2	10	10
3	5	5
4	10	10
5	6	8
6	7	9
7	9	8
8	8	6
9	5	5
10	4	4
11	3	3
12	3	3
13	2	2
14	5	5

**NOTE**

For manual tuning or presetting, the Autotune positioning heads are unlocked. The Autotune system must not be operated while in this condition, since channel settings for all channels will probably be lost. Tighten the locking key before Autotune operation.

The Autotune control circuits, which form the electrical part of the system, are used to control the multiturn and single turn positioning heads that comprise the mechanical part of the system. A schematic diagram of the Autotune control circuits, mechanical representation illustrations of the single turn and multiturn positioning heads, and a flow chart, (fig. 1-43) which shows the sequence of events during Autotune operation is provided for use with the following paragraphs.

**1-37. Autotune Control Circuit**  
(fig. 1-44)

**NOTE**

In Radio Transmitter T-195B/GRC-19 on Order No. 4096-PP-60, hermetically sealed autotune relay K610 (used in the T-195A/GRC-19 and early T-195B/GRC-19) and unsealed autotune relay K610 (used in the T-195/GRC-19) are replaced with an equivalent hermetically sealed relay K610. Terminal numbers of the sealed relay corresponding to the contact numbers of the unsealed relay are given in the chart below.

The Autotune control circuits properly position the multiturn and single turn positioning heads, so that the desired set of operating conditions are set up in the transmitter. The positioning heads are initially adjusted to provide eight sets of conditions (frequency settings), each of which corresponds to one of the eight positions of PRESET CHANNELS switch S604. The Autotune control circuits perform a complete cycle of operation each time the Autotune cycle is initiated, regardless of the frequency channel selected. The operation is as follows:

a. Switches S604 and S605 are connected so that when S604 is in any position, S605 must be in a corresponding position to break a ground path through their connecting leads. Because during a previous Autotune cycle, S605 has been adjusted to S604 so that the ground path through the switches is broken, the rotation of S604 to a new channel position will re-establish the ground path. This ground path is maintained in any one of seven positions of S605, through switches S604, and S606, and through S605 to limit switch S617. Switch S606 connects S605 to a channel switch in Transmitter Control C-822/GRC-19 when S606 is in the REMOTE position. The ground connection to S617 initiates the Autotune cycle; to complete the cycle S605 must be finally rotated to the one position which breaks the ground path to S617.

b. Limit switch S617 is composed of two microswitches which are operated by an actuating arm, the movement of which is controlled through a slip clutch and lost motion drive by Autotune motor B601. Figure 1-44 shows the limit switch

when the Autotune cycle has been completed. When a ground connection is supplied to S617, contacts 3 and 4 connect the ground to terminal 1 of Autotune relay K610, 24 volts are connected to terminal 2 of K610, and the relay is energized.

c. When K610 is energized, the following occur:

(1) Alternate ground connections are provided for terminal 1 of K610 through contacts 7 and 8 of K610, contacts 6 and 5 of S617, contacts 5 and 6 of K610, and open-circuit seeking switches S604 and S605.

(2) A potential of 24 volts is applied to terminal F1 of B601 through contacts 4 and 3 of K610, and to terminal A1 of B601 through contacts 4, 3, 9, and 10 of K610.

(3) A ground connection is made through contacts 12 and 13 of K610 to terminal A2 of B601.

(4) Autotune muting relay K609 is energized; this disables the output capacitor selection circuit, the homing circuits, and the high-voltage circuits until after the Autotune cycle is completed (fig. 1-51).

d. The voltage and ground connections to Autotune motor B601 (c(2) and (3) above) energize the motor, the rotation of which provides the occurrences listed in (1) through (3) below.

#### NOTE

During the Autotune cycle, the motor rotation is in either of two directions. For explanation purposes, they will be referred to as the first and the second directions.

(1) S605 is mechanically connected to B601 through a ratchet drive that rotates S605 when the motor rotates in the first direction. (S605 has no stops, and rotates continuously in one direction.)

(2) B601 drives the actuating arm of S617 through a lost motion drive and slip clutch. The lost motion drive permits 1 complete revolution of S605 before it engages the switch (S617) side of the drive, so that contacts 5 and 6 of S617 maintain a ground connection to the coil of K610 when S605 passes the one position that breaks the ground path through S605 and S604. When the lost motion drive is engaged, the actuating arm of S617 is driven so that contacts 3 and 4 are opened, and 1 and 2 are closed (because of a spring-return mechanism). The motor continues to rotate in the first direction until con-

tacts 5 and 6 of the limit switch S617 are opened. This breaks the ground path through S617 to the coil of K610, and leaves one remaining ground path through S604, S605, and contacts 6 and 5 of K610 to the coil. At this time the clutch slips and the motor continues to rotate in the first direction.

(3) The motor continues to rotate until S605 is at the position that breaks the ground path to relay K610. When this occurs, relay K610 becomes deenergized. Cam switch S616 is synchronized with S605 so that a ground connection is maintained to K610 until S605 is in the exact center of its open position. This ensures precision control of the Autotune positioning heads.

e. When relay K610 is deenergized, the polarity of the voltage applied to terminals A1 and A2 of motor B601 is reversed. Twenty-four volts are applied to terminal A2 through contacts 2 and 1 of S617, and through contacts 14 and 13 of K610; terminal F1 receives 24 volts through contacts 2 and 1 of S617. The reversal of voltage polarities at terminals A1 and A2 reverses the direction of rotation of the motor, and the motor then rotates in the second direction. This produces the following effects:

(1) S605 remains stationary because of the ratchet drive, and the lost motion drive rotates in the second direction. The lost motion drive must make a complete revolution before the switch (S617) side of the drive is engaged and the actuating arm is moved in the second direction.

(2) When the actuating arm of S617 is moved, contacts 5 and 6 close, but this has no effect on the circuits because contacts 8 and 7 of K610 are not connected.

(3) The motor continues to rotate until the actuating arm of S617 opens the connection between contacts 1 and 2, and connects contacts 3 and 4 of the switch together. This removes the 24 volts from the Autotune motor, and the Autotune control circuits are again in their original state, except that S605 and S604 are positioned at the new preset channel.

#### NOTE

The sequence of events described above provides for the proper adjustment of the positioning heads. When B601 rotates in the first direction, the positioning heads are prepared for final adjustment, which is performed when B601 rotates in the second direction.

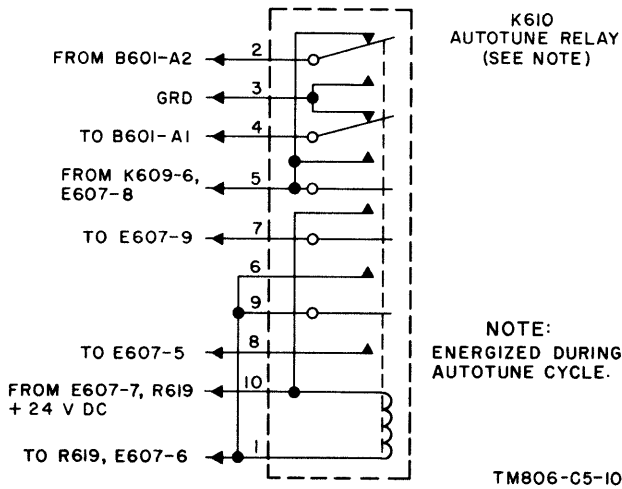

Figure 1-45. Hermetically sealed autotune relay K601, schematic diagram.

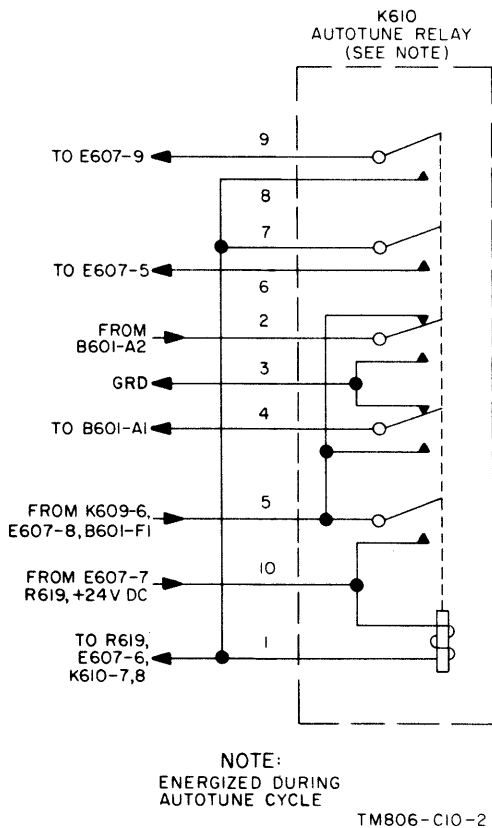

Figure 1-46. Hermetically sealed autotune relay K610, (used in T-195B/GRC-19 on order No. 4096-PP-60), schematic diagram.

**1-38. Single Turn Positioning Head**  
(fig. 1-47)

The first and second directions of rotation mentioned in *a* through *f* below correspond in time and direction to those mentioned in paragraph

1-37. Figure 1-47 is a simplified diagram of the single turn positioning head, the operation of which is as follows:

*a.* Autotune control motor B601 drives worm gear 1 in the first direction so that gear 2 rotates in the direction indicated by the solid arrow (fig. 1-47). Gears 2 and 3 are fastened together, and rotation of gear 2 causes rotation of cam drum 7 through gears 3, 5, and 6, and ratchet drive 8.

*b.* A clutch action exists between gear 2 (and 3) and shaft 4. Stop-ring drum 9 rotates in the first direction until rotation stop 10 halts the shaft rotation, and the clutch slips. Cam drum 7 continues to rotate until the Autotune motor reverses direction (para 1-37).

*c.* Cam drum 7 is composed of eight slotted rings, the slots of which are evenly spaced around the drum so that each slot corresponds to a position of switch S605 in the Autotune control circuits; ring 1 is synchronized with the first position of S605, etc. Pawl stack 11 is composed of eight pawls, each of which has a heel and a toe. The pawl heels ride on their corresponding cam drum rings; this keeps the pawl toes in a back position and does not allow the toes to fall into the slots on stop-ring drum 9. The pawl heels are tapered, so that when the cam drum rotates in the first direction, the heels fall partly into their respective slots, but ride out of the slot as the drum continues to rotate. If, in the first direction, a pawl toe falls into its slot on the stop-ring drum, the cam drum rotation will cause the pawl heel to ride out of the cam drum slot and thus raise the heel and disengage the toe from the stop ring. At the beginning of the Autotune cycle, one of the pawl toes is engaged in its respective stop ring, and during the first half-cycle of Autotune operation, the stop ring becomes disengaged, or cleared, in preparation for the second half-cycle.

*d.* The position of S605 in the Autotune control circuit, when it causes Autotune motor B601 to reverse direction, determines which cam drum ring is positioned, so that its slot is directly beneath its respective pawl heel.

**NOTE**

The rotation of the cam drum is identical with that of S605. The cam drum rotates continuously in the first direction only, in a manner similar to that of S605. When B601 reverses to rotate in the second direction, the cam drum remains stationary because of ratchet drive 8.



e. Shaft 4 can rotate in the second direction until rotation stop 10 is engaged; this limits the rotation of shaft 4 and stop ring drum 9 to approximately three-fourths of a turn. This means that when the stop ring drum is rotated, three-fourths of its circumference will pass the pawl toes. The stop rings are preadjusted so that during the rotation all of the stop ring slots pass beneath the toes. When a stop ring slot moves under the pawl toe which has been released by its corresponding pawl heel, the toe will fall into the slot, and the stop ring drum and shaft 4 will be held stationary. Because band switches S101 and S201 are mechanically linked to shaft 4, they will be positioned according to the setting of the stop ring slot which has engaged its pawl toe. Autotune motor B601 will continue to rotate (in the second direction), but the clutch will slip, and shaft 4 will not be moved.

f. For the initial channel frequency setting, a key on the BAND SELECTOR knob is loosened, which allows an engaged stop ring to slip on shaft 4. The other seven stop rings maintain their relative position to each other and the shaft, so that when the BAND SELECTOR knob is rotated (manually), seven stop rings, the shaft, and the band switches are rotated. The engaged stop ring is held stationary, and the frequency band setting at which the BAND SELECTOR is set becomes the new band setting for that stop ring. When the key is locked, all stop rings are fastened securely to each other and the shaft.

### 1-39. Multiturn Positioning Head (fig. 1-48)

The multiturn positioning head is controlled simultaneously with the single turn head, so that the directions of rotation (first and second) correspond to those in paragraphs 1-37 and 1-38. The principles of operation are basically the same as those for the single turn head, in that the cam drum is rotated to disengage the stop-ring drum, which is then rotated during the first half-cycle to a *home* or starting position. The cam drum in the multiturn head is synchronized with S605 and the single turn head cam drum, so that it is properly positioned when S605 causes a reversal of the Autotune motor rotation. The multiturn head, however, differs from the single turn head in that it must control tuning devices which require several rotations. For this reason, an additional drum (known as the counter drum), which permits the controlling shaft to rotate several times before the stop ring drum is

engaged by its pawl toe, is used. The operation of the multiturn positioning head is as follows:

a. Autotune control motor B601 drives worm gear 1 in the first direction, which causes cam drum 2, mounted on shaft 3, to be rotated through the action of gears 4, 5, 6, 7, and 8, and ratchet drive 9 in the direction indicated by the solid arrow (fig. 1-48). The pins of gear 6 pull pawl-lifter lever 10 back, thus rotating pawl-lifter arm 11, which in turn rotates pawl-lifter shaft 12. The rotation of shaft 12 lifts all pawls of pawl stacks 13 and 14 away from the drums, allowing the drums to rotate. Cam drum 2 rotates continuously until the Autotune motor reverses direction, leaving the drum positioned so that the cam drum slot corresponding to the channel selected is directly beneath its respective pawl heel.

b. Stop-ring drum 18, mounted on shaft 17, is driven by the action of gears 1, 4, 15, and 16. Slip clutch action exists between shaft 17 and gear 16. Counter drum 19 is rotated by gear 20, mounted on shaft 17, through the action of gears 21, 22, 23, sun gear 24, and planetary gear 25, which is attached to the counter drum. Small planetary gear 25 rides between sun gear 24 and ring gear 26. This arrangement results in the counter drum rotating 10 times more slowly than the stop ring drum. Gear 27 is coupled to sun gear 24, and drives gear 28 at approximately the same speed as the counter drum. The pins on gear 28 limit the rotation of shaft 17 to 10 turns. During the rotation in the first direction, one of the pins eventually pushes stop anchor assembly 29 to draw rod 30 backward, and rotates home-stop pawl 31, so that home stop 32 becomes engaged. This stops the rotation of shaft 17, thereby stopping the rotation of the stop-ring drum and the counter drum. When this occurs, clutch 3 slips until the motor reverses its direction.

c. When S605, in the Autotune control circuits, causes the Autotune motor to reverse direction, cam drum 2 is left stationary because of the action of ratchet drive 9. The pins of gear 6 now push pawl-lifter lever 10 forward, which rotates pawl-lifter arm 11 so that the flat surface of shaft 12 is turned up, thereby releasing the pawls so that they can operate normally. The pawl heel corresponding to the channel selected enters the cam drum slot, allowing the pawl toe to ride against the corresponding counter drum ring. Gear 34 is friction-coupled to the counter drum, and is driven through gears 20, 21, and 35. Normally, gear 34 slips against the counter

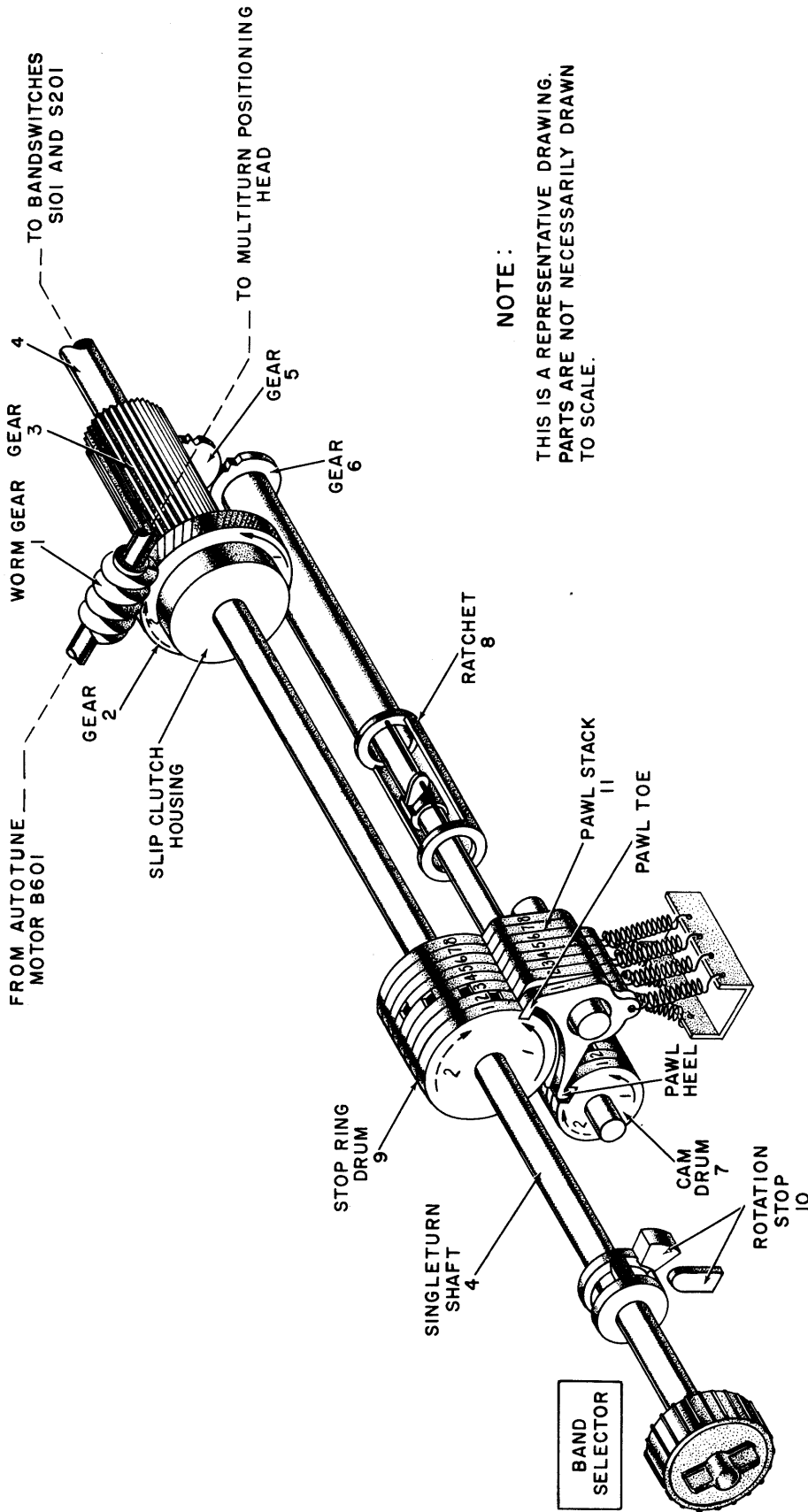

NOTE:  
THIS IS A REPRESENTATIVE DRAWING.  
PARTS ARE NOT NECESSARILY DRAWN  
TO SCALE.

TM 806-53

Figure 1-47. Single turn positioning head, simplified drawing.

drum, except during the short interval that the pin on ring gear 26 is free to travel between the arms of stop 36. During this short interval, gear 34 rotates the counter drum at an increased rate of speed until stop 36 halts the rotation of gear 26, and gears 24 and 25 again control the rotation of the counter drum. When rotation is reversed in either direction, this arrangement advances the counter drum slot slightly ahead of the stop ring drum to allow the pawl toe of the counter drum to enter its slot just before the pawl toe of the stop ring drum passes over the slot. This permits manual tuning in either direction.

*d.* When the Autotune motor rotates in the second direction, the pawl toe of pawl stack 14 rides against its counter drum ring until the slot in the ring passes under it. Because the counter drum rotates at one-tenth of the speed of shaft 17, the stop-ring drum may rotate several times before the counter drum is engaged by the pawl toe. The counter drum slots are longer than those of the stop-ring drum, and when the pawl toe enters the slot in the counter drum ring, the rotation continues for a short time. During this time, the pawl toe of pawl stack 13 rides against its ring on the stop drum until the toe enters its slot. When this happens, rotation of shaft 17 is stopped and the tuning cores of the master oscillator and exciter subchassis are positioned accordingly.

*e.* A key on the TUNING CONTROL knob is loosened for initial frequency setting, allowing the engaged stop ring to slip on the shaft (para 1-38). During manual tuning the second direction, a limit rotation is established by a pin on gear 28, which operates the stop mechanism to push rod 30 forward. This rotates home stop pawl 31 so that home stop 32 is engaged, stopping the rotation of shaft 17.

## 1-40. Summary of Transmitter Tuning

(fig. 1-49)

*a.* The flow chart of figure 1-49 gives the sequence of events when a new operating channel

is selected by the operator. When the PRESET CHANNELS switch is moved to a new position, and the SERVICE SELECTOR switch is in any position other than OFF, the Autotune system will function. If the SERVICE SELECTOR switch is in CALIB or STAND BY position, the output capacitor selection and homing circuits will not function. If the SERVICE SELECTOR switch is in CW or VOICE/FSK position, the circuits will function as described in the flow chart. It can be seen from the chart, that each tuning operation must be completed before the succeeding circuits can function. When the TUNING INDICATOR lamp is lit, the transmitter is completely tuned, and is transmitting rf energy.

*b.* The following information summarizes the action resulting from the movement of the frequency controls in the VOICE/FSK position with the microphone button depressed.

(1) Move BAND SELECTOR from (1.7-2.0) to (3.0-4.0).

(a) Exciter band switch is rotated.

1. Selects output capacitor position.

2. Selects variable inductor homing position.

(b) Pa band switch is rotated.

(c) Selects proper BAND SELECTOR dial position.

(d) Selects proper counter mask position.

(e) Momentarily closes S-203. Homing relay K616 is operated.

(2) Move TUNING CONTROL from 1.790 to 3.800.

(a) Rotates mo shaft.

(b) Rotates frequency counter.

(c) Positions exciter slug rack.

(d) Transmitter automatically tunes and loads.

(e) TUNING INDICATOR lights.

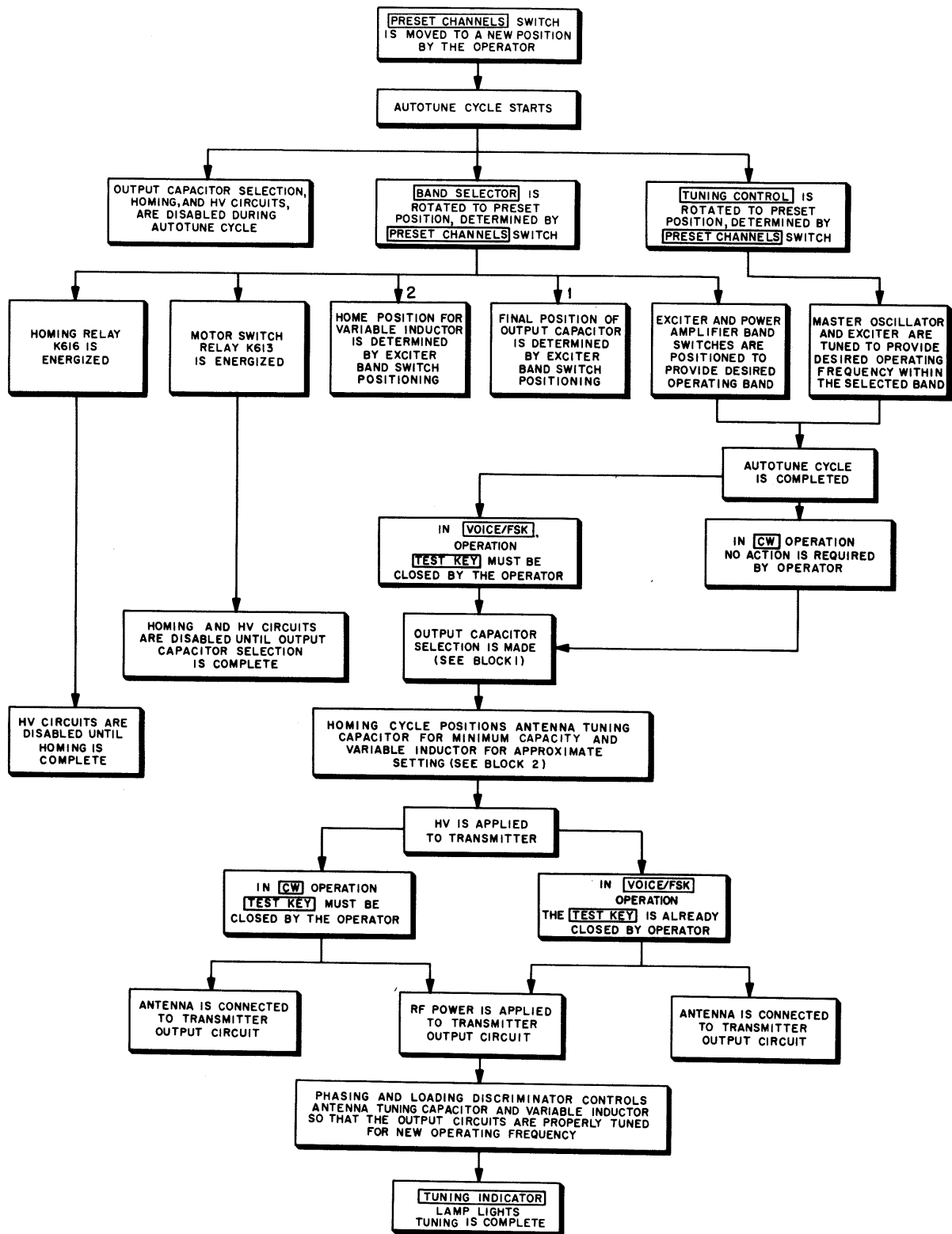

TM 806-122

Figure 1-49. Complete tuning cycle, flow chart.

**Section X. POWER CIRCUITS AND SERVO MOTORS**

**1-41. General**

Primary power for Radio Transmitter T-195/GRC-19 is supplied from a 24-volt source which is capable of delivering at least 44 amperes of current. Operating voltages for the transmitter are supplied by two dynamotors or transistor-type power supplies which are mounted in the transmitter. In Radio Transmitter T-195A/GRC-19, operating voltages are supplied by a low-voltage dynamotor and a high-voltage power supply both mounted in the transmitter. The flow chart (fig. 1-50) shows the general relationship of the main parts of the power circuits, and paragraphs 1-42 through 1-48, and figures 1-50 through 1-59 give more detailed information on these circuits.

**1-42. Distribution, 24-Volt**  
(fig. 1-51)

**NOTE 1**

In Radio Transmitter T-195B/GRC-19 on Order No. 4096-PP-60, unsealed autotune relay K608 (used in the T-195/GRC-19) and hermetically sealed autotune relay K608 (used in the T-195A/GRC-19 and early T-195B/GRC-19) is replaced with an equivalent hermetically sealed relay K608. Terminal numbers of the sealed relay corresponding to the contact numbers of the unsealed relay are given in the chart below.

<i>Radio Transmitter T-195/GRC-19 K608 contact No.</i>	<i>Radio Transmitter T-195A/GRC-19 and early T-195B/GRC-19 K608 terminal No.</i>	<i>Radio Transmitter T-195B/GRC-19 (Order No. 4096 PP 60) K608 terminal No.</i>
1	4	4
2	7	7
3	2	2
4	3	3
5	7	5
6	5	7
7	7	7
8	6	1
9	7	7
10	1	6

**NOTE 2**

In Radio Transmitter T-195B/GRC-19 on Order No. 4096-PP-60, unsealed LV relay K602 (used in the T-195/GRC-19, T-195A/GRC-19, and early T-195B/GRC-19) is replaced with hermetically sealed relay K602. Terminal designations of the sealed relay corresponding to the contact numbers of the unsealed relay are given in the chart below.

*Radio Transmitter T-195/  
GRC-19, T-195A/GRC-19,  
and early T-195B/GRC-19  
K602 contact No.*

*Radio Transmitter T-195B/  
GRC-19 (Order No. 4096-  
PP-60) K602 terminal*

1	+ light duty terminal.
2	unmarked light duty terminal.
3	+ heavy duty terminal.
4	unmarked heavy duty terminal.
5	-----

The primary power of Radio Transmitter T-195/GRC-19 is 24 volts dc. The positive line is connected to the transmitter through pins A and B of the 24 VOLTS DC receptacle, J605; the negative line is connected through common pins C and D of J605 to chassis ground. Pin A of J605 is connected to pin D of the RECEIVER CONT receptacle, J604, to furnish primary power for Radio Receiver R-392/URR. The 24-volt input to the transmitter is fed through the capacitor-input-filter circuits of Z601 to fuses F601, F602, and F603.

*a. Filament Start Relay.* Twenty-four volts are applied through 15-ampere fuse F601 to terminal 2 of relay K608. The other side of the relay coil (terminal 1) is connected through CR602 to contact 3 on K608, contact 11 on S606A (rear), and contact 8 on S606C (front). Contact 4 of K608 is connected to terminal 2 S606A (rear) through cabinet thermostat S608. Contact 4 of S606A (rear) connects to ground through the plugs and receptacles of the antenna-tuning capacitor subchassis, the variable inductor subchassis, and the power amplifier subchassis, blower thermostat S610, and blower thermostat S202. This arrangement prevents operation of the equipment with any one of the three subchassis disconnected. When SERVICE SELECTOR switch S606 is rotated from the OFF position, relay K608 is energized and voltage is applied through contacts 2 and 8, and contacts 9 and 10 of K608 to the following circuits:

(1) *Blowers.* Twenty-four volts are applied to exhaust blower B602 through contacts 9 and 10 of K608 and the line-filter circuit composed of C622 and L614. Twenty-four volts are also applied through contacts 7 and 8 of K608 and through J608-13 and P201-13 to power-amplifier blower B202. If B202 should become defective, or if insufficient cooling air is delivered to the plate of V201, blower thermostat S202 deenergizes K608 and removes all power from the transmitter. When K608 is deenergized, 24-v dc is applied through normally closed contacts 5 and 6 of K608, through S60C (rear) contacts 10 and 11, through S609 contacts 5 and 7, and through

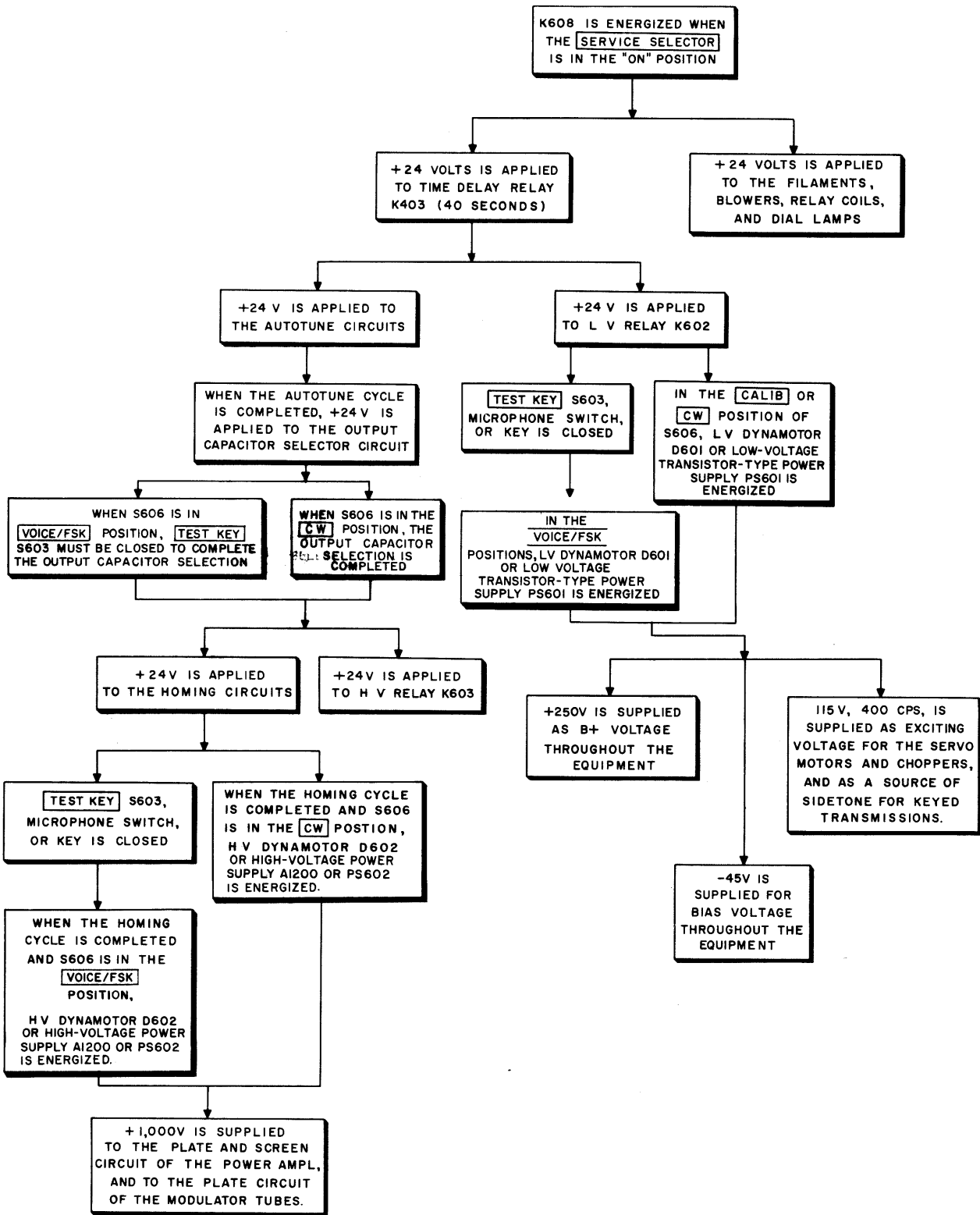

TM5820-335-35-13

Figure 1-50. Power circuits, flow chart.

R615 to the tuning indicator I 605. When S609 is operated to the OVERHEAT CHECK RED LIGHT ON position after thermal overload, tuning indicator I 605 will light. Capacitors C249, C209, C210, L206, and R239 serve as a line filter B202.

## (2) Filaments.

(a) Filament power is supplied through contacts 7 and 8 of K608 to V801, V802, V203, V204, V901, V903, V904, V902, V404, V401, V403, and V402. Twenty-four volts from contacts 7 and 8 of K608 are connected through R611, J617-C to P802-C to filaments of V802 and V801 in series. Capacitor C632 is an rf filter for this 24-volt circuit. On main frame MOD 5A and higher, capacitor C668 is added as a filter in parallel with capacitor C632, and capacitor C669 is added as a filter preceding resistor R611 in the circuit. Twenty-four volts are connected through J608-13 and P201-13 to the filament of V203, V204, and R235 in series. Shunt current resistor R234 is connected in parallel with R235 and V204. Twenty-four volts are connected through J611-15 and P901-15 to V901, V903, and R931 in series. Twenty-four volts are connected through J611-15 and P901-15 to V904, V902, and R932 in series. Twenty-four volts are connected through J606-18 and P401-1, through R412, V404, V402, V401, and V403 to ground. Shunt current resistor R417 is connected in parallel with V402, V401, and V403. Thermostat S801 provides compensation whenever the surrounding temperature falls below 0° C. At this time, the thermostat contacts close, and 24 volts are applied to the heater element. Heat resulting from the current flow through the element raises the surrounding temperature, and the contacts open. Capacitor C812 serves as a spark suppressor for the contacts of S801.

(b) Filament power is supplied through contacts 9 and 10 of K608 to V202, V101, V102, V103, and V104. Twenty-four volts from contacts 9 and 10 of K608 are connected through J607-11, P101-11 to V101, V102, V103, and R123 in series. Shunt current resistor R121 is connected with V102, V103, and R123. Twenty-four volts from contacts 9 and 10 of K608 are connected through J607-11 and P101-11 to V104, through P101-14, J607-14, R617, R616, J608-8, P201-8, and V202 in series.

(c) Filament voltage is supplied to V201, V406, and V407 from two separate sources. During periods of standby, twenty-four volts from contacts 9 and 10 of K608 are connected to

R623, R622, J608-2, P201-2, and V201. A parallel connection is made from J608-2 to J606-20, P401-20, and to V406 and V407 in parallel. This places all three tubes in parallel with their total filament current drawn through the voltage dropping resistors R623 and R622. This arrangement provides approximately 20 percent reduction of filament voltage for the power amplifier tube and the two modulator tubes. During periods of operation, twenty-four volts are supplied through contacts 4 and 5 of 1v relay K602, F602, CR601 (a high current silicon diode) to the filaments of V201, V406, and V407 in parallel. This arrangement allows full filament voltage to be applied to all three tubes during operation and reduced voltage to be applied to these tubes during standby. Back resistance of CR601 isolates the 24-volt filament voltage from the dynamotor during standby.

(3) *Discriminator relay K201.* When the BAND SELECTOR control is set for operation in the 1.5- to 6-mc range, this relay is energized by completing the coil circuit to ground through S101D (front).

(4) *Transformer shorting relay K203.* When the SERVICE SELECTOR switch is set to the VOICE/FSK position, this relay is energized by completing the coil circuit to ground through contacts 4 and 5 of S606B (rear).

(5) *Test meter M602.* Twenty-four volts are applied to current-limiting resistor R614, and when TEST METER switch S607 is set to the BATT position, the voltage is applied to the meter through contacts 10 and 8 of the switch. The negative side of M602 is connected to ground through contacts 2 and 4. The meter then indicates the value of input voltage to the transmitter.

(6) *Frequency dial lamps.* Twenty-four volts are fed to contact 8 of DIAL DIM switch S609. When this switch is rotated to the DIM position, connection is made between contacts 8 and 9; and lamps I 602, I 603, and I 601 are connected in a series arrangement, each lamp receiving 8 volts. When S609 is set to the FULL position, connection is made between contacts 1 and 12; and contacts 8, 9, and 10 are connected together. This connects the lamps in a parallel arrangement, and each lamp receives 24 volts. When a thermal overload occurs, filament start relay K608 is deenergized by operation of one of the protective thermostats S202, S608, or S610. Operating S609 to OVERHEAT CHECK RED LIGHT ON position connects 24 volts through normally closed contacts 5 and 6 on

K608, contacts 10 and 11 on S606C (rear), and contacts 6 and 7 on S609 to tuning indicator I 605.

(7) *Keying relay K605.* Twenty-four volts are applied to terminal 1 of the relay coil, which is energized when the TEST KEY, or an external key or microphone switch, connects terminal 8 of K605 to ground through R621. The relay is also energized when S606 is set to the CALIB position.

(8) *Motor switch relay K613.* Twenty-four volts are applied to terminal 1 of the relay coil, which is energized when terminal 5 finds a path to ground through open-circuit-seeking switches S614A and S101C. This occurs when the BAND SELECTOR control is moved to a new position (para 1-3).

(9) *Homing relay K616.* Twenty-four volts are applied to terminal 1 of the relay coil, which is energized when terminal 10 is connected to ground through the homing circuits. This occurs when the BAND SELECTOR control is moved to a new position.

(10) *Autotune relay K610.* Twenty-four volts are applied to terminal 2 of the relay coil and to the Autotune circuits. Terminal 1 of K610 is grounded through the Autotune circuits.

(11) *Voice relay K402.* Twenty-four volts are applied to terminal 1 of the relay coil, which is energized by connecting terminal 6 to ground through contacts 4 and 5 of S606B (rear) when the SERVICE SELECTOR switch is set to the VOICE/FSK position.

*b. Time-Delay Relay K403.* When contacts 3 and 4 of filament start relay K608 close, 24 volts is applied to thermal time-delay relay K403. This relay delays application of power to the dynamotors or transistor-type power supplies and to certain circuits to allow a warmup period of 40 seconds for tube filaments. In Radio Transmitter T-195A/GRC-19, this relay delays application of power to the low-voltage dynamotor and the high-voltage power supply, and to certain circuits to allow a warmup period of 40 seconds for the tube filaments. When contacts 5 and 7 of relay K403 close, voltage is applied through cabinet interlock S611 to the following circuits.

(1) *Low-voltage relay K602.* Twenty-four volts are applied to terminal 1 of the relay coil, which is energized when terminal 2 is connected to ground through S606A (front). When SERVICE SELECTOR switch S606 is set to the CALIB or CW position, a ground path is provided through contacts 1 and 12 of S606A (front). When S606 is set to the STANDBY position,

K602 cannot be energized. In the VOICE/FSK position of S606, the relay is energized by TEST KEY S603, which provides a ground path to the relay coil through its own contacts (9 and 10), and contacts 9 and 10 of S606A (front).

#### NOTE

The TEST KEY is connected in parallel with the external key or microphone switch; therefore, either the TEST KEY, external key, or microphone switch will control the low-voltage relay. When the low-voltage relay is energized, 24 volts from the power source is applied through J605-A, capacitor-input filter of Z601, the series winding of the relay, contacts 5 and 4 of the relay, and 10 ampere fuse F602 to low-voltage dynamotor D601 or low-voltage transistor-type power supply PS601. The series winding (terminals 3 and 5) of K602 prevents damage to the relay contacts. When the relay contacts close, the high surge current flowing through this series coil keeps the contacts closed until the dynamotor has come up to speed and the input current has dropped to a safe value. When energized, D601 or low-voltage transistor-type power supply PS601 furnishes 115 volts at 400 cps, +250 volts, and -45 volts as operating voltages for the transmitter. Choke L623 is provided in the +250-volt output line of the dynamotor as an rf line filter.

(2) *Output capacitor motor (B603).* Twenty-four volts are applied through the normally closed contacts of Autotune muting relay K609 to B603 and to contact 4 of motor switch relay K613. When relay K613 is energized, the negative side of the motor is connected, through current-limiting resistor R605 and contacts 3 and 2 of K613, to contact 2 and 11 of S606A (front). In the CW position of the SERVICE SELECTOR switch, the motor circuit to ground is completed through contacts 11 and 12 of the switch. In the VOICE/FSK position, contact 11 is connected to contact 9 and 10 so that in this position of S606, the TEST KEY (or external key or microphone switch) must be closed to energize the motor. When the motor rotates open-circuit-seeking switch S614A to a position that will break the ground circuit of K613 (a(8) above), the relay becomes deenergized and the ground circuit to R605 is broken.



(3) *Homing circuits.* Twenty-four volts are applied to contact 3 of homing relay K616 through the normally closed contacts of Autotune muting relay K609 and motor switch relay K613. When homing relay K616 is energized, the voltage is distributed as follows:

(a) Voltage is applied through dropping resistor R620 and contacts 7 and 8 of K616 to the phasing servo amplifier. This voltage is used to rotate the antenna-tuning-capacitor motor during homing.

(b) Voltage is removed from terminal 1 of hv relay K603.

(c) Twenty-four volts are applied through contacts 4 and 3 of K616 to motor reversing relay K617. This relay controls the polarity of the voltage applied to homing motor B1102. Reversing switch S1101B controls the action of K617, and motor disabling relay K604 disables servo motor B1101 during homing (para 1-29). Capacitor C644 prevents arcing between contacts 3 and 4 of K616 when power is applied to or removed from homing motor B1102. R1101 is a current-limiting resistor for motor B1102.

(4) *High-voltage relay K603.* Terminal 2 of K603 is connected to contacts 2 and 11 of S606A (front). In the VOICE/FSK position of S606, terminal 2 of K603 is connected to ground through contacts 11 and 9 of S606A (front) and the test key S603 or external key or microphone switch. When the Autotune cycle has been completed, the antenna-output-capacitor selection has been made, the homing cycle has been completed, and K616 is deenergized, 24 volts is applied to terminal 1 of K603 through contacts 2 and 3 of K609, 4 and 3 of K613, and 3 and 2 of K616. This energizes the high-voltage relay K603. When the switch is set to the CALIB or STANDBY position, the ground connection cannot be made, and high voltage cannot be applied to the equipment. When the coil of K603 is energized and thus closes contacts 4 and 5, voltage is applied through the relay contacts, the series winding of the relay, and 30 ampere fuse F603 to high-voltage dynamotor D602 or high-voltage power supply A1200. The series winding of K603 (terminals 3 and 5) acts in the same manner as that of the low-voltage relay to protect the relay contacts from damage caused by arcing ((1) above). The hv dynamotor or high-voltage power supply A1200 supplies +1,000 volts to the plates of the type 4X150D tubes in the modulator and the power amplifier subchassis. In

Radio Transmitter T-195A/GRC-19, the high-voltage power supply furnishes +1,000 volts for the plates of the type 4X150D tubes in the modulator and the power amplifier subchassis. The filter circuit composed of C659, C623, L602, and L610 removes ripple voltages from the +1,000-volt output. The input voltage of D602 or A1200 is also applied through the contacts of antenna delay relay K601 (when keying relay K605 is energized) to antenna switching relay K614 and receiver antenna relay K615. To prevent arcing in the relay contacts, a set of contacts (5 and 6) on relay K615 provides a high starting current to the coil of K614. Both relays operate together; when they are energized and the contacts of K615 open, voltage is applied only through current-limiting resistor R610 to the coil of K614.

**1-43. Distribution, 115-Volt, 400 Cps**  
(fig. 1-54)

The low-voltage dynamotor, D601 or low-voltage transistor-type power supply PS601, supplies 115 volts at 400 cps to the circuits shown in the functional diagram (fig. 1-54). The input circuit to D601 or low-voltage transistor-type power supply PS601 is shown in figure 1-51.

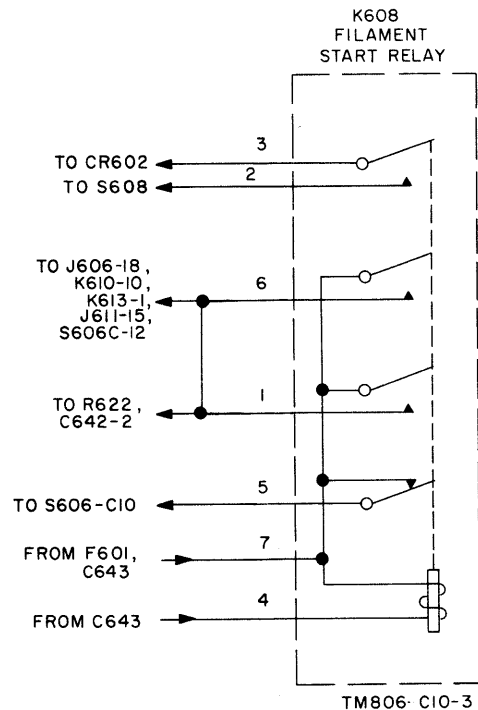

Figure 1-52. Hermetically sealed autotune relay K608 (used in T-195B/GRC-19 on Order No. 4096-PP-60) schematic diagram.

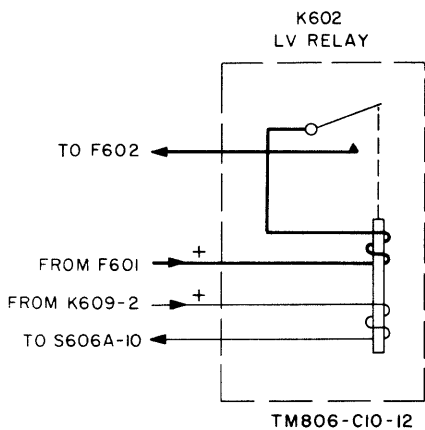

Figure 1-53. Hermetically sealed LV relay K602 (used in T-195B/GRC-19 on Order No. 4096-PP60), schematic diagram.

a. To furnish excitation voltage for the motor windings, 115 volts is fed directly to servo motor B1001 and through the contacts of K604 to servo motor B1001. During homing (fig. 1-30), the motor disabling relay is energized, and excitation voltage is removed from B1101. 115 volts is also applied to servo motor V201 through pin 12 of P201.

b. The 115 volts is also applied to transformer T901 through the RC combination of R929 and C924, which provides a 25° phase shift in the voltage. Compensation for phase shift in the initial voltage due to circuit components is provided by C922, C921, and C923. Transformer T901 reduces the 115-volt input to 6.3 volts, which is used as exciting voltage for choppers G901 and G201. The output of T901 is also fed through voltage-dropping resistor R914 to provide 3 volts at 400 cps to sidetone amplifier V403A.

**1-44. Distribution, +250-Volt**  
(fig. 1-55)

Plate and screen voltages for the tubes of Radio Transmitter T-195/GRC-19 are generally supplied from the +250-volt output of low-voltage dynamotor D601 or low-voltage transistor-type power supply. Input voltage is supplied from a +24-volt source, as shown in figure 1-51. The +250-volt output of D601 is fed through the af choke to the various subchassis (fig. 1-55).

**1-45. Distribution, -45-Volt**

The lv dynamotor or low-voltage transistor-type power transmitter for use in the antenna switching and supply, supplies -45 volts to the keying

circuits (fig. 1-41). In addition, this supply is used as a bias voltage for modulator tubes V406 and V407 (fig. 1-26), and as a source of bias for power amplifier tubes V201 and V202 (fig. 1-16).

**1-46. Distribution, +1,000-Volt**

High-voltage dynamotor D602 or PS602 supplies +1,000 volts for use as plate and screen voltage for the power amplifier tube (fig. 1-16). In addition, +1,000 volts are applied to the center-tapped primary winding of the modulation transformer to provide plate voltage for V406 and V407 (fig. 1-26). The +24-volt input circuit of D602 or high-voltage power supply A1200 or PS602 is shown in figure 1-51.

**1-47. Transistorized High-Voltage Power Supply Operation**

The high-voltage power supply contains eight PNP-type transistors connected in what is popularly known as a common-collector, saturable-core, square-wave oscillator. The significant difference of this circuit, is that four transistors are paralleled on each half of the primary of transformer T1200. This is done to increase the current-handling capabilities of the circuit more than that which is usually encountered in the basic two transistor saturable-core oscillator. For more complete understanding of the circuit operation, a simplified diagram is presented (fig. 1-56) using two transistors Q1203 and Q1207, with only those components necessary for simplified circuit operations. A simplified circuit is described in a above; a description of the actual circuit is described in b below.

a. *Basic Saturable-Core Oscillator.* The oscillatory action for the circuit (fig. 1-56) depends on the unbalance existing between the apparently identical circuits of transistors Q1203 and Q1207. This is due to both external circuitry and transistor unbalance which is brought about by manufacturing tolerances. Assume that because of these unbalances, transistor Q1203 conducts a little heavier than Q1207. With the polarity of the battery (representative of the input voltage source) as shown, electron flow in the external circuit will be from the emitter (e<sub>1</sub>) through resistor R1203 to terminal 1 of transformer T1200, returning to the plus side of the battery through terminal 2 of the primary. The current flow through the primary will induce a voltage in the secondary (terminals 6 and 5) which will aid the bias voltage, developed by the voltage drop

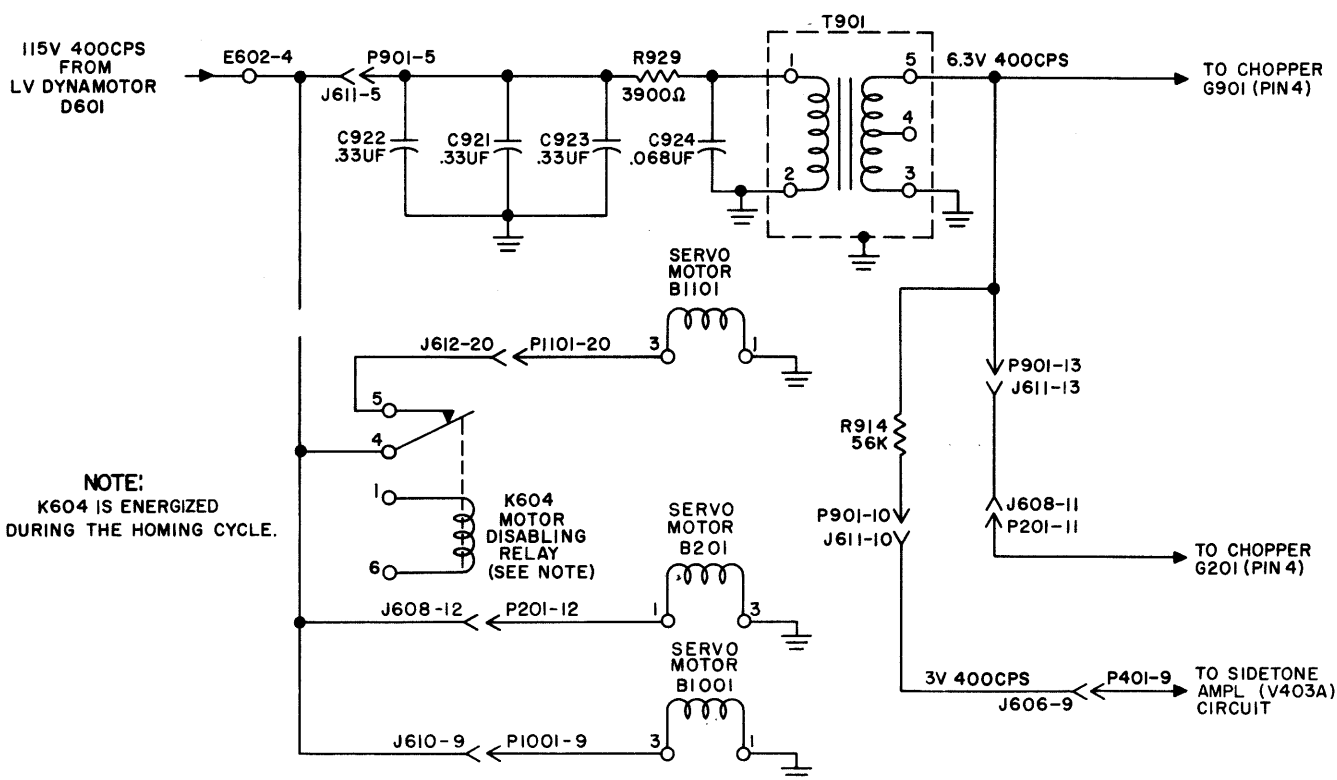

Figure 1-54. 115-volt, 400 cps distribution, functional diagram.

across R1207, (voltage drop across R1213 in power supplies labeled MOD 1), on the base (b) of transistor Q1203, causing an increase in conduction. The increase in conduction will cause a further increase in emitter current ( $I_c$  flowing through the primary of T1200, inducing a greater voltage in the secondary. As is readily apparent, the increase in secondary induced voltage will impress a larger bias-aiding voltage on the base of Q1203, facilitating a still larger increase in conduction. This action is cumulative with Q1203 conduction increasing rapidly. The cessation point for Q1203 conduction is determined by the core saturation of transformer T1200. The core material is such that the hysteresis losses permit a buildup of flux density to a point where any further increase in applied primary current will not permit an increase in the magnetic field strength. When this occurs, the voltage which was being induced in the secondary by the increasing primary current will decrease removing the conduction aiding bias from Q1203. With the reduction of the conduction aiding bias voltage on the base of Q1203, conduction will drop rapidly to the starting point. This will cause the current through the primary of T1200 to

drop and the primary magnetic field will collapse. When the primary field collapses, a voltage will be induced in the secondary which is of opposite polarity to that described above for Q1203 conduction. This voltage, of opposite polarity, will oppose the base bias and cut off Q1203. At the same time, the induced voltage will aid the base bias voltage applied to Q1207, and allow it to conduct. Operation is now switched from Q1203 to Q1207 going through the same cycle of events as described above for Q1203. This action occurs at a rate (frequency) of 1,600 cps with the production of a square-wave type wave form. In summary, Q1203 and Q1207 function as switching transistors and T1200 is the saturable-core transformer which determines the switching rate (frequency of oscillation). Resistors R1203 and R1212 are current-limiting devices, resistor R1207 (R1213-R1214 in power supplies labeled MOD 1) is the base bias voltage-dropping resistor, and the battery (BATT.) is the input voltage source.

b. High-Voltage Power Supply Operation (fig. 1-57).

(1) In the explanation given in a above, only transistors Q1203 and Q1207 were con-

TM 806-58

sidered. With Q1200, Q1201 and Q1202 connected in parallel to Q1203 and Q1204, Q1205 and Q1206 connected in parallel to Q1207, the maximum total emitter current ( $I_e$ ) that could flow through each primary (terminal 1-2 and 2-3) during their respective cycles is now increased four times.

(2) To obtain the required voltage and current from the power supply, three secondaries are used. Each secondary develops approximately one-third of the total output voltage. To combine the secondary outputs, three bridge-type rectifier circuits are connected in series, using R1204 and R1205 as a common lead, across which the output voltage is developed. This voltage represents the sum of the three individual bridge rectifier circuit output voltages.

(3) Silicon diodes CR1200 through CR1203 make up the bridge circuit for the top secondary, terminals 7 and 8. Silicon diodes CR1204 through CR1207 make up the bridge circuit for the middle secondary, terminals 9 and 10. Silicon diodes CR1209 through CR1212 make up the bridge circuit for the bottom secondary winding, terminals 11 and 12. To filter out ac variations in the output, C1201 and C1202 are placed across the lead, R1204 and R1205. Essentially pure dc is applied to terminal board E603, terminal 1, located on the main frame of the transmitter.

(4) As shown in the simplified diagram (fig. 1-56), resistor R1207 is connected from T1200, terminal 5, (effectively the transistor bases), to the positive side of the input voltage source. The voltage drop across R1207 develops the normal base bias voltage during operation. However, during the initial starting period, bias is developed by resistor R1208, connected from relay K1200-5 to ground. Diode CR1214 clamps this initial bias voltage at a negative polarity with respect to the input voltage. Approximately 2.5 milliseconds after starting, relay K1200 energizes and normally closed contacts 5-3 open and contacts 3-6 close. This disconnects R1208, bypasses CR1214, and connects R1207 into the circuit. This circuit is a protective feature. Should a short circuit occur across the output of the secondary, the oscillator will stop and, since the starting bias resistor is out of the circuit it will not restart. If the oscillator were able to restart with a shorted power supply; a runaway condition would occur, damaging the transistors.

(5) In power supplies labeled MOD 1 (fig. 1-58), the voltage drops across R1213 and R1214 that develop during alternate periods of transistor conduction, form the required operating bias voltages.

(6) As explained in *a* above, when the primary current reaches saturation the lack of current change in the primary will cause the magnetic field to collapse. When this field collapses, a voltage of positive polarity will also be induced in the primary, increasing the emitter voltage. To prevent this instantaneous voltage from damaging the emitter junctions of the transistors, two diodes are provided to bypass this voltage. When the instantaneous voltage is developed across the top primary (fig. 1-57), terminals 1-2, the anode of diode CR1203 will become more positive than the cathode and will conduct, thereby bypassing the ac instantaneous voltage through capacitor C1204 to ground. Resistor R1206 decouples the instantaneous voltage from the input source voltage. When the instantaneous voltage is developed across the bottom primary, terminals 2-3, diode CR1213 conducts in the same manner as described for CR1203. In power supplies labeled MOD 1, the circuit composed of CR1208, CR1213, C1204, and R1206 is omitted and inductor L1200 is added between the two groups of parallel connected bases of the transistor switching circuits (fig. 1-58). This change results in a considerable reduction of power dissipated in the emitter junctions, eliminates the possibility of transistor damage by excessive heating of the emitter junctions, and increases the overall efficiency of the power supply. The favorable conditions result because inductor produces a faster rise time during the switching cycle by going into saturation before transformer T1200. This causes T1200 to saturate faster than it would with L1200 out of the circuit. Because of the faster rise time, the voltage induced into the primary of T1200 by a collapsing magnetic field is impressed upon the transistor emitter junctions for a shorter period of time than without the inductor. Capacitor C1203 serves as a filter to smooth out variations in the input source voltage. Resistors R1200 through R1203 and R1209 through R1212 are placed in series with the emitters of Q1200 through Q1203 and Q1204 through Q1207 respectively, serving as current-limiting devices for additional stability.

(7) Cooling and air circulation for the high-voltage power supply is provided by an ac axial fan. The fan, B1200, is a 55-volt ac, 1,600-cycle type, connected directly across the primaries of T1200, terminals 1 and 3. Capacitor C1200 serves as a starting capacitor for B1200. As the current through the primaries periodically changes, these changes are reflected in the field winding of the fan, causing it to rotate. An im-

peller mounted on the fan shaft draws air in through holes on the power supply case. In power supplies labeled MOD 1, a long metal plate is secured to the transistor chassis in contact with the metallic body of each transistor. This plate acts as a heat sink that permits more efficient conduction of heat from the transistors to the outer case of the power supply. The improved head dissipation results in a lower transistor internal temperature.

**1-48. Servo Motor Operation**  
(fig. 1-59)

The servo motors (B201, B1001, and B1101) used in Radio Transmitter T-195/GRC-19 and two phase induction motors. Each motor has two windings; one winding receives voltage from the 115-volt, 400 cps supply, and the other receives voltage from the output circuit of its respective servo amplifier.

**NOTE**

The following discussion is general and does not refer to a particular circuit. The transmitter servo circuits, however, are all basically the same, with minor exceptions.

a. The dc error voltage from a discriminator is applied to the input circuit of a servo amplifier, where a chopper (G201 or G901) converts the dc voltage to a square wave. Because of circuit characteristics in the amplifier, the output of the servo amplifiers will be essentially an ac voltage.

b. The exciting voltage which is applied to the coil of each chopper (or to the circuit of a transistorized chopper) is obtained from the initial 115-volt, 400-cps supply, but is reduced to 6.3 volts and shifted in phase (25°) (para 1-43).

The impedance of the chopper coil is such that an additional 65° phase shift is introduced. In the transistorized choppers, a phase-shift circuit introduces an additional 65° phase shift. The chopper will then convert the dc voltages to a 400-cycle square wave, which will lead or lag the initial 115 volts by 90°, depending on the polarity of the dc error voltages from the discriminator.

c. As shown in A, figure 1-59, the current waveform A is applied to the coil of the chopper. With the transistorized chopper, current wave form A causes the transistors to alternately ground the dc voltage so that a square wave is produced, such as wave form B (if error voltage is positive) or C (if error voltage is negative). Refer to figure 1-36 for the transistorized chopper circuits. This causes the chopper to alternately ground the dc voltage, so that a square wave is produced, such as waveform B (if error voltage is positive) or C (if error voltage is negative). The square wave is then applied to the servo amplifying circuits, the outputs of which will appear as D (for positive square wave) or E (for negative square wave). The servo amplifier output is applied to winding W1, which is arranged so that its fields are perpendicular to those of winding W2. The current waveform F from the initial 115-volt supply is applied to W2, and leads or lags the input to W1 by 90°. This results in an effectively rotating magnetic flux being applied to the rotor of the motor.

d. Because of the currents induced in it, the rotor acts like a magnet which alines itself with the resultant magnetic field generated by the motor windings. As the currents in the field windings vary in direction and magnitude, the resultant magnetic field effectively rotates. The rotor follows this rotating magnetic field. For this discussion, it is assumed that a positive error voltage is generated by the discriminator, and waveform D is applied to W1. Waveform D leads waveform F (the voltage applied to W2) by 90°. Therefore, the magnetic field of W1 leads the magnetic field of W2 by 90°.

e. The direction of the magnetic field created by a positive voltage through W1 is indicated by an arrow pointing to the top of the page. A negative voltage results in a field direction indicated by the broken arrow pointing downward. In W2, the direction of the field caused by a positive voltage is indicated by the arrow pointing to the right. The broken arrow pointing to

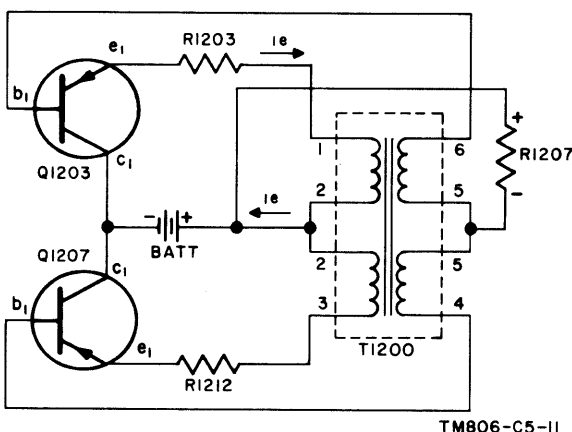

Figure 1-56. Transistorized power supply, schematic diagram.

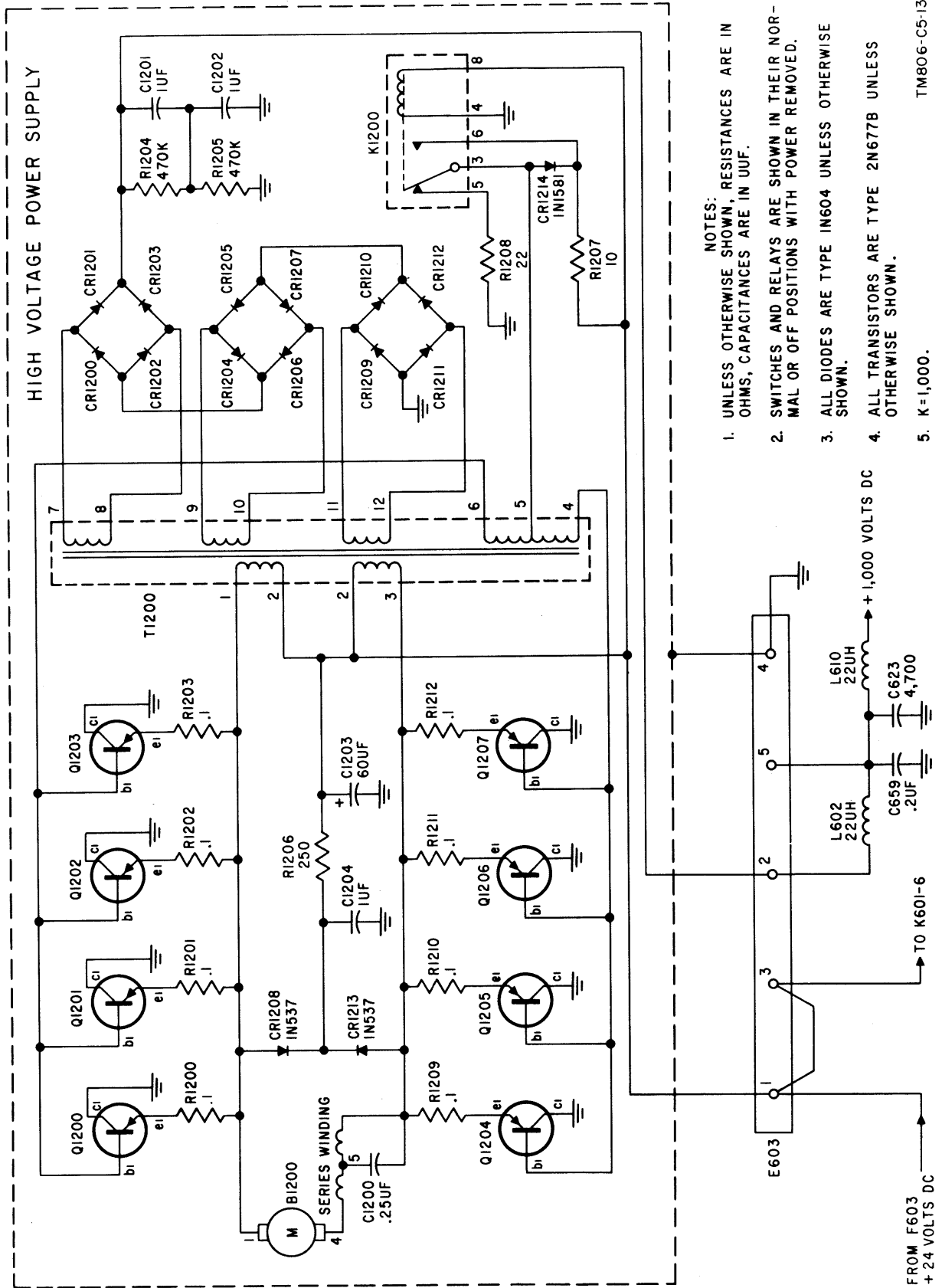

Figure 1-57. High-voltage power supply A1200, schematic diagram.

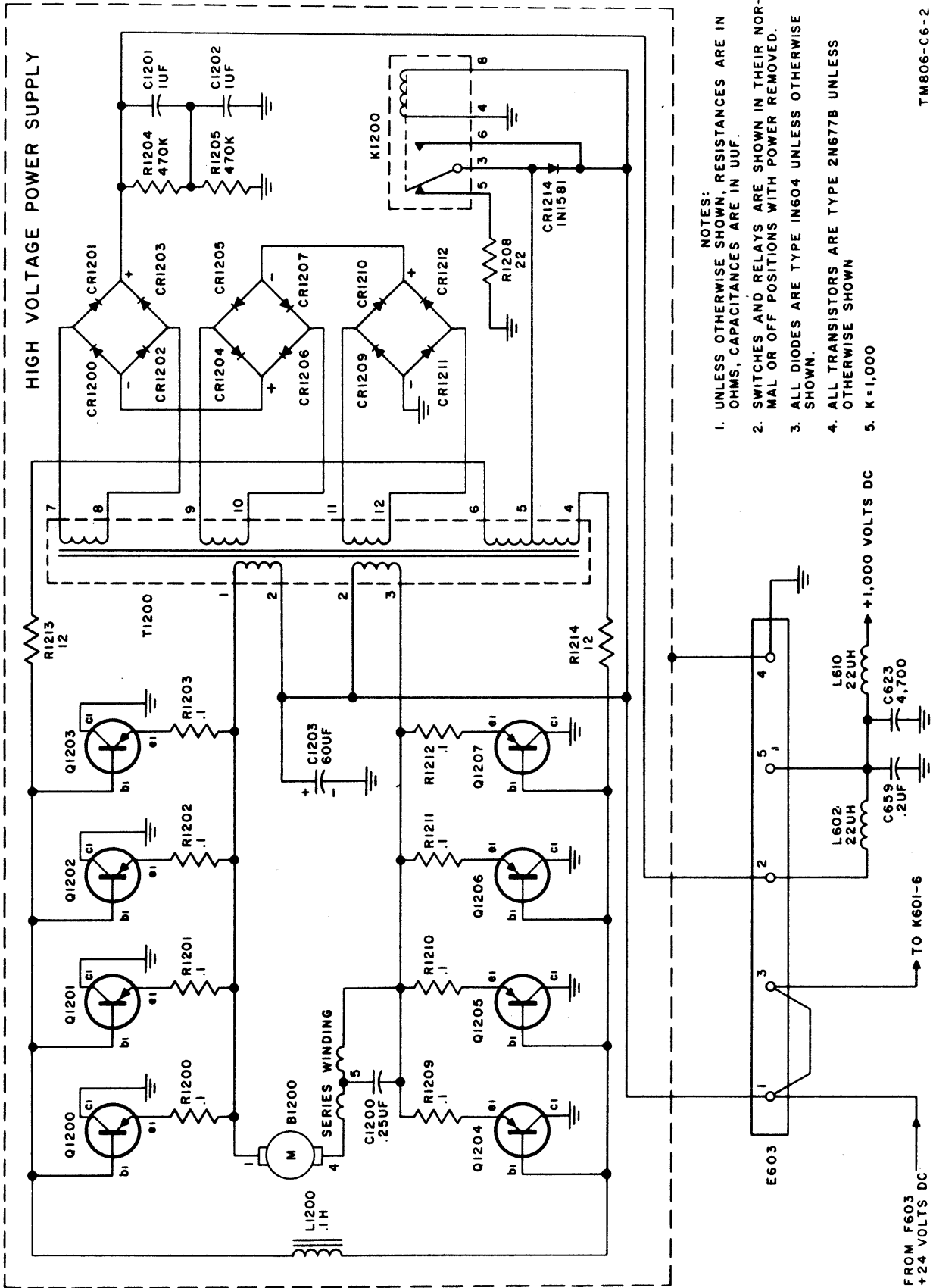

Figure 1-58. High-voltage power supply A1200 (MOD1), schematic diagram.

TM806-C6-2

the left indicates the direction of the field caused by a negative voltage in W2. B, figure 1-59, illustrates the effect of combining the two fields at different times to produce a rotating magnetic field which the rotor follows.

f. If no error voltage is present, a current is not applied to W1 and a flux is induced by W2 which alternates but does not move in a rotary direction. The motor will not rotate under this condition. If a negative voltage is generated by the discriminator, the magnetic field and the rotor will rotate in a counterclockwise direction.

#### 1-49. Transistor-Type Exhaust Blower B602 (fig. 1-60)

In the Radio Transmitter T-195B/GRC-19, the dc motor is replaced with a transistorized dc to ac inverter and ac motor. Two power transistors, Q601 and Q602, are used in a push-pull, grounded collector-type oscillator that provides 400 cycles ac for the operation of motor B604. Toroid-type transformer T601 determines the switching rate (frequency of oscillation) of the two transistors. Resistors R631 and R634 in the base circuits of Q601 and Q602 are current limiting resistors. Resistor R632 is the base bias voltage dropping resistor for Q601, and resistor R633 and capacitor C672 provide a feedback path to sustain oscillations in the stage. Capacitor C671 provides the required phase shift to the field winding of B604 for power motor starting. Capacitor C673 reduces the transient voltage spikes produced in T601 by the switching action of the transistors.

#### 1-50. Transistor-Type Pa Blower B202 (fig. 1-61)

In Radio Transmitter T-195B/GRC-19, an ac drive motor replaces the dc motor used in earlier models of this blower. A separate transistor-type dc to ac inverter provides power for the ac motor. Transistorized blower B202 performs the same function as, and is directly interchangeable with, the dc blower. Two power transistors, Q201 and Q202, with toroid-type transformer, are used to form a 400-cycle push-pull, grounded collector oscillator. Resistors R241 and R242 are base current limiting resistors, and resistor R243 develops the base bias voltage. Capacitor C253 provides a feedback path for the oscillator circuit. Capacitor C252 produces the phase shift to the field winding of B202, necessary for blower motor starting.

#### 1-51. Low-Voltage Transistor-Type Power Supply (fig. 1-62)

a. *General.* In Radio Transmitter T-195B/GRC-19, a low-voltage transistor-type power supply is used instead of the low-voltage dynamotor. The power supply is interchangeable with the dynamotor unit. The power supply consists of an oscillator section, a power amplifier, a rectifier and filter section to produce +250-volt dc output, a regulated 115-volt 400-cps ac output, and a -41-volt dc bias output section.

b. *Voltage Regulator Circuit.* Resistor voltage dividing network R675, R676, and R677 supplies proper operating voltages from the +28-volt input source to dc input regulator Q603. The regulator maintains a constant 7.5-volt input to oscillator transistors Q604 and Q605. Zener diode CR603 is connected across the regulator input circuit and protects the transistors against damage from sharp transients which might appear at the input to the power supply. Should such a spike appear, CR603 will break down and shunt the Q603 input. The large value of capacitor C675 keeps the voltage applied to the transistors constant for the duration of the transient.

c. *Push-Pull Oscillator Circuit Q604 and Q605.* Adjustable resistor R678, series-connected with the emitters of Q604 and Q605, is used to adjust the frequency of the push-pull oscillator circuit. Capacitors C676 and C677 and resistors R679 and R680 form the feedback circuits for the two transistors. The saturable core of T602 helps maintain a uniform square wave output to the power amplifier.

d. *Power Amplifier.* The center-tapped secondary of transformer T602 provides the out-of-phase input signals to push-pull power amplifier transistors Q606 and Q607. Resistors R681 and R682 provide proper bias for the transistors and capacitors C678 is a filter capacitor for the emitters. The center-tapped primary of T603 serves as the load for the collectors.

e. *250-Volt Dc Output Circuit.* The secondary of T603 consists of two windings, one winding applies the 400-cps square wave to bridge rectifier circuit CR604 through CR607. Resistor R683, functions as a current surge limiting resistor during the initial charging period of output filter capacitor C679. Resistor R684 serves as a bleeder for the 250-volt dc output.

f. *115-Volt, 400-Cps Ac Output Circuit.* The other secondary winding of transformer T603 applies the 400-cps square wave voltage through choke coil L625 to saturable reactor voltage reg-



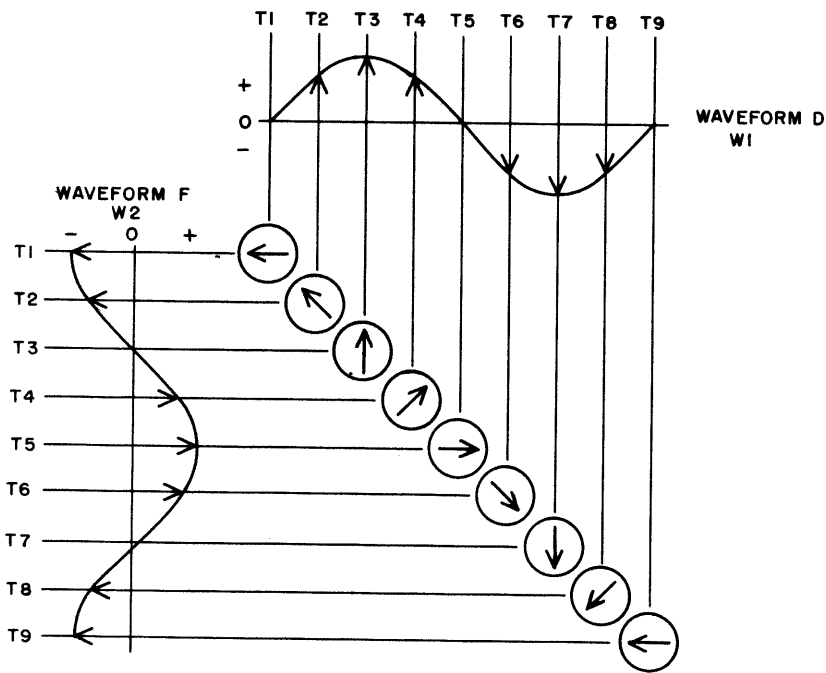
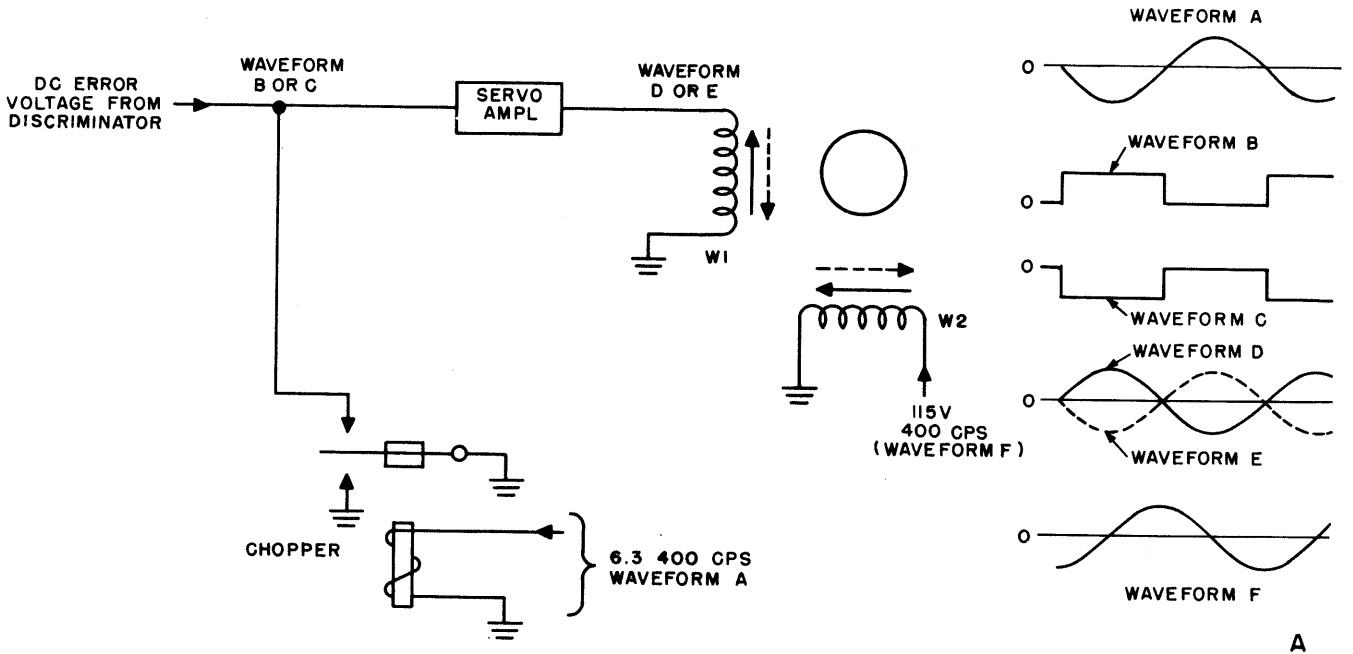

B  
TM 806-9

Figure 1-59. Servo mechanism operation.

ulator L626. Capacitor C681 rounds off the corners of the square wave voltage, and L627 and C682 form a series resonant circuit that shapes the applied voltage into a sinusoidal output. Blower B605 is connected across the 115-volt ac output, and C683 provides the required phase shift for blower motor starting.

g. *-41 Volt Dc Bias Output Circuit.* The tap on the secondary winding of T603 applies a square wave voltage to half wave rectifier CR611. The rectified voltage is filtered by rc filter C685, C686, and R691. Resistor R690 serves as a bleeder across the bias voltage output. Diode CR612, parallel-connected with filter resistor

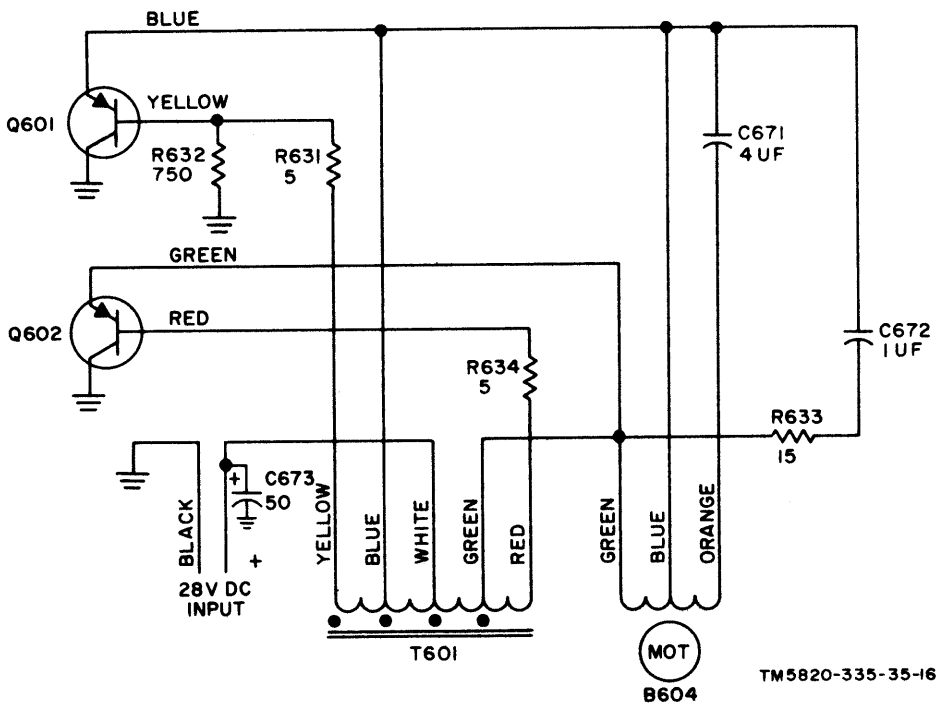

TM5820-335-35-16

Figure 1-60. Exhaust blower B602, transistor type, schematic diagram.

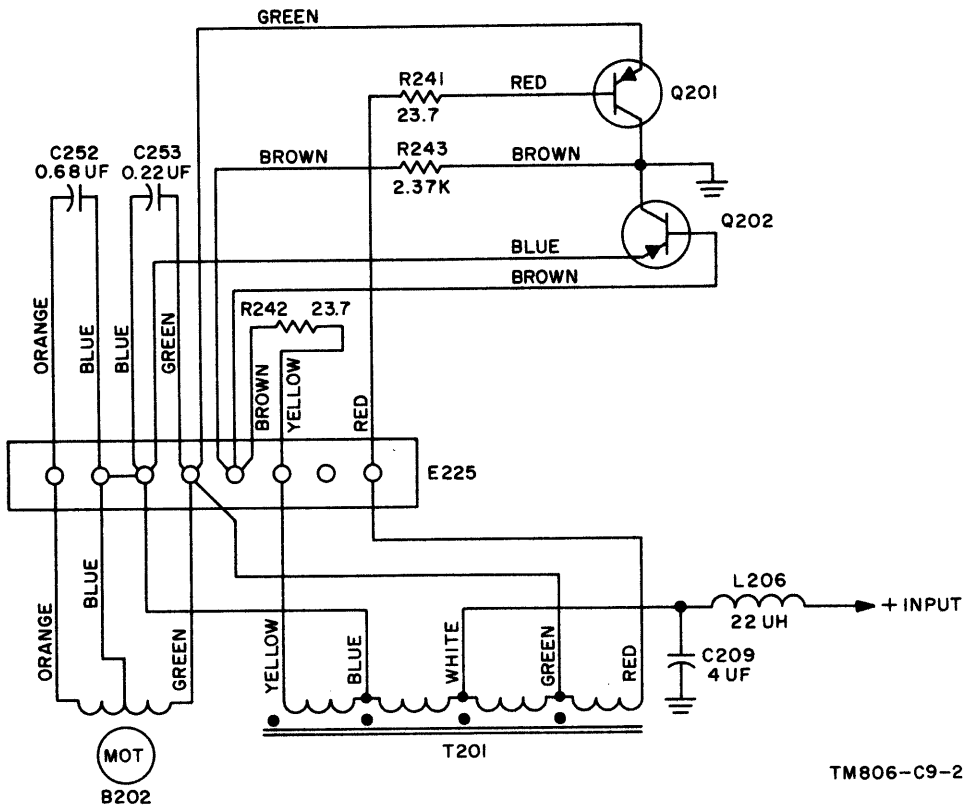

TM806-C9-2

Figure 1-61. Pa blower B202, transistor-type schematic diagram.

R691, provides an access to ground for the control grid of the pa stage in the event there is grid current flow.

*h. Protection Circuit.* Relay K1 protects the 250-volt dc supply and the 115-volt ac supply against an overload.

(1) The 250-volt dc protection circuit consists of R711 and R685 in parallel, CR609, R687, and relay K1. One side of relay K1 solenoid is connected to the +28-volt dc supply voltage and the other side is series-connected with R687 and CR609 to the 250-volt dc output. The polarity of the voltage across CR609 is such that the diode is normally nonconducting. Two normally closed contacts of relay K1 are used to short parallel-connected resistors R711 and R685. A short circuit across the 250-volt output will place the +250-volt dc output terminal at ground potential and CR609 will conduct. This action energizes relay K1 and the normally closed contacts open, placing current limiting resistors R685 and R711 in series with the load.

(2) The 115-volt 400-cps ac output circuit is protected by current limiting resistor R688. This resistor is placed in series with the load when relay K1 is energized. Transistor Q608 is used as a switch to complete the dc path to ground for the solenoid winding of relay K1 in the event of a short circuit in the 115-volt ac load. The base voltage on Q608 is determined by R693, R694, and R692 and, under normal conditions, Q608 is biased to cutoff. Should a short circuit occur across the ac load, the negative voltage on the base is reduced, and Q608 conducts. This action completes the circuit from K1 to ground through Q608 to the +28-volt dc input. When K1 is energized, R686 and CR608 are shunted across the solenoid of K1 to prevent an induced voltage from damaging the transistors when the short circuit has been removed. A diode network, connected between the base and emitter of Q608 reduces the voltage spikes at the base of Q608.

## 1-52. High-Voltage Transistor-Type Power Supply (fig. 1-63)

*a. General.* In Radio Transmitter T-195B/GRC-19, a high-voltage transistor-type power supply is used instead of the high-voltage dynamotor unit. This power supply is interchangeable with the dynamotor unit. The power supply consists of a 1,600-cps multivibrator, a power amplifier, and a rectifier and filter section.

*b. 28-Volt Input and Multivibrator Circuits.* The +28-volt dc input to the power supply is fed through voltage dropping resistors R697 and R698 to provide the proper potential on the emitters of transistors Q609 and Q610. Capacitor C691 filters the input to the power supply. A starting surge protector Zener diode, CR613, is parallel-connected with the emitters of transistors Q609 and Q610 and ground. The Zener diode has a breakdown voltage of 17 volts dc. Any voltage in excess of this value will cause the diode to conduct and thereby protect the transistors. Transistors Q609 and Q610, the center-tapped primary winding of T604, C689 and C690, and R695 and R696 form an oscillatory circuit that produces a 1,600-cps square wave voltage.

*c. Power Amplifier Circuit.* Two secondary windings on T604 apply the operating potentials to amplifier section Q611 through Q618. Each center-tapped secondary feeds four transistors in a push-pull parallel arrangement. The load for the eight power amplifier transistors are four windings on the primary of transformer T605, each winding serving as the load for two push-pull-connected transistors. The four primary windings of T605 are connected in phase.

*d. 1,000-Volt Dc Output Circuit.* Two secondary windings of T605 feed bridge rectifiers Q614 through Q617 and Q618 through Q621. The outputs of the two bridge circuits are series-connected to provide a 1,000-volt dc output from the rectifier. Capacitors C693 and C694 filter the rectifier output, and resistors R709 and R710 function as the bleeder. The third winding on the secondary of T605 provides 230 volts ac for operation of a built-in power supply blower, with capacitor C695 providing the phase shift required for blower motor starting. Relay K626 protects the 1,000-volt dc power supply in the event of a short circuit across the load. This protective circuit consists of resistors R707, R708, diodes CR622 and CR623, and relay K626. One side of the K626 solenoid winding is connected to the +28-volt dc input. The other side of the solenoid winding is series-connected with CR628 and CR622 and the normally closed contacts of K626 to the 1,000-volt dc output. The normally closed contacts short circuit R707 and R708. Under normal conditions, the voltage across CR622 and CR623 prevents the diodes from conducting, and K626 remains deenergized. A short circuit across the 1,000-volt dc output causes the diodes to conduct and K626 becomes energized. The normally closed contacts are opened and the

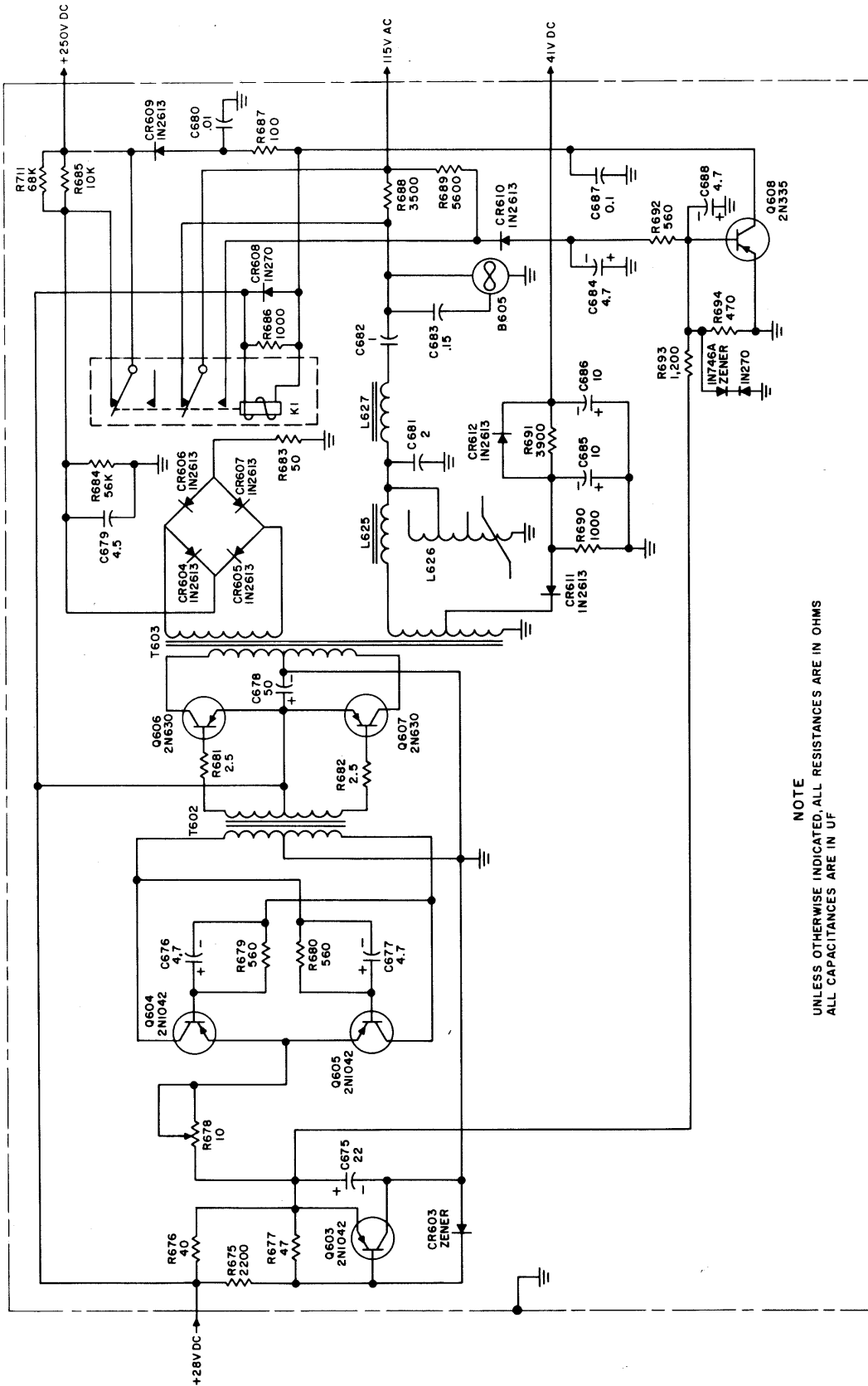

NOTE  
UNLESS OTHERWISE INDICATED, ALL RESISTANCES ARE IN OHMS  
ALL CAPACITANCES ARE IN UF

TM 5820-335-35-17

Figure 1-62. Transistor-type low voltage power supply, complete schematic diagram.

short circuit is removed from R707 and R708, placing a high value of resistance in series with the 1,000-volt dc load.

### 1-53. High-Voltage Transistor-Type Power Supply PS602 Operation (fig. 1-64)

*a. General.* In Radio Transmitter T-195B/GRC-19 on Order No. 4096-PP-60, a transistor-type high-voltage power supply is used in place of the high-voltage dynamotor unit and other transistor-type high-voltage power supplies. This power supply is interchangeable with the dynamotor and previous high-voltage power supplies. The power supply consists of a 540-cps multivibrator oscillator, a starting trigger circuit, a rectifier circuit, a filter circuit, and a cooling fan circuit. These circuits have been molded into four modules; start module Z1, control module Z2, 1,000-volt output module Z3, and fan module Z4, to which are added the other components required to make the unit operational.

#### *b. Simplified Operation.*

(1) The 27.5-volt dc input voltage is applied to start module Z1 and to the power oscillator circuit consisting of transformer T1, control module Z2, transistors Q1 and Q2, diodes CR1 and CR2, and resistors R1 and R2. Capacitors C301 and C302 filter the input to the power supply. Oscillations are started in the power oscillator circuit by a pulse from start module Z1. After an initial starting pulse is generated, start module Z1 is disabled until the power supply is overloaded or turned off. During oscillation, transistors Q1 and Q2 conduct alternately, as determined by control module Z2, and generate a square-wave alternating current in the primary windings of transformer T1. Diodes CR1 and CR2 prevent the emitter-to-base voltage on transistors Q1 and Q2 from rising to an excessive value. Resistors R1 and R2 limit the current to the base terminals of the transistors.

(2) The secondary windings of transformer T1 are connected to three full-wave bridge rectifier circuit CR301 through CR312. The three rectifier circuits are series-connected to produce the required 1,000-volt dc output; each circuit contributes one-third of the output voltage. The 1,000-volt output is applied to filter capacitor C3 and a series bleeder resistor combination consisting of resistors R301, R302, and R305. The negative output is connected to the common ground lead (black), and the positive output is connected to the 1,000-volt output lead (red)

through resistor R306; resistor R306 limits the output current from the power supply in the event of a short circuit.

(3) One of the secondary windings of transformer T1 is tapped to provide excitation voltage for fan module Z4. The module consists of two-phase fan motor B401 and phase shifter capacitor C401. The fan module provides an axial flow of air through the power supply for cooling the components.

#### *c. Detailed Operation.*

(1) For this discussion, it is assumed that the power supply is operating and that transistor Q1 is in a conductive state. A discussion of the initiation of oscillation by start module Z1 is given in (3) below.

(2) Transistor Q1 is saturated in the conductive state by a forward biasing voltage induced into T1 primary winding, terminals 5 and 6 (in parallel with terminals 19 and 20), from primary winding, terminals 2 and 15, when Q1 conduction is initiated by the starting pulse from start module Z1 ((3) below). A small current also flows from the input power source through saturable inductor L201, diode CR201, and the base and collector of transistor Q1 to ground. After a time determined by the characteristics of inductor L201, the inductor core saturates, and the current through the inductor rises sharply. This raises the potential on the base of transistor Q1 until the base becomes positive with respect to the emitter, and Q1 is cut off. The current through T1 primary winding, terminals 2 and 15, drops sharply and induces a forward-biasing voltage in primary winding, terminals 7 and 8 (in parallel with terminals 17 and 18), which drives transistor Q2 into conduction. The same sequence of events is repeated for transistor Q1 again conducts completing a cycle. The 540-cps switching rate is controlled by L201.

(3) In normal operation, start module Z1 supplies only the one pulse require to initiate oscillation in the power oscillator circuit. Thereafter, the start module circuits are normally disabled. When transistor Q1 (Q2 in PS601) is conducting, its base voltage is close to ground potential. Since this voltage is applied through resistor R105 to the collector of transistor Q102, no pulses are generated because of the low collector voltage. When transistor Q1 (Q2 in PS601) is cut off, the base voltage is approximately twice the input voltage (+60 volts). This voltage is applied through resistor R104 to base b2 of transistor Q101. Diode CR101 limits the

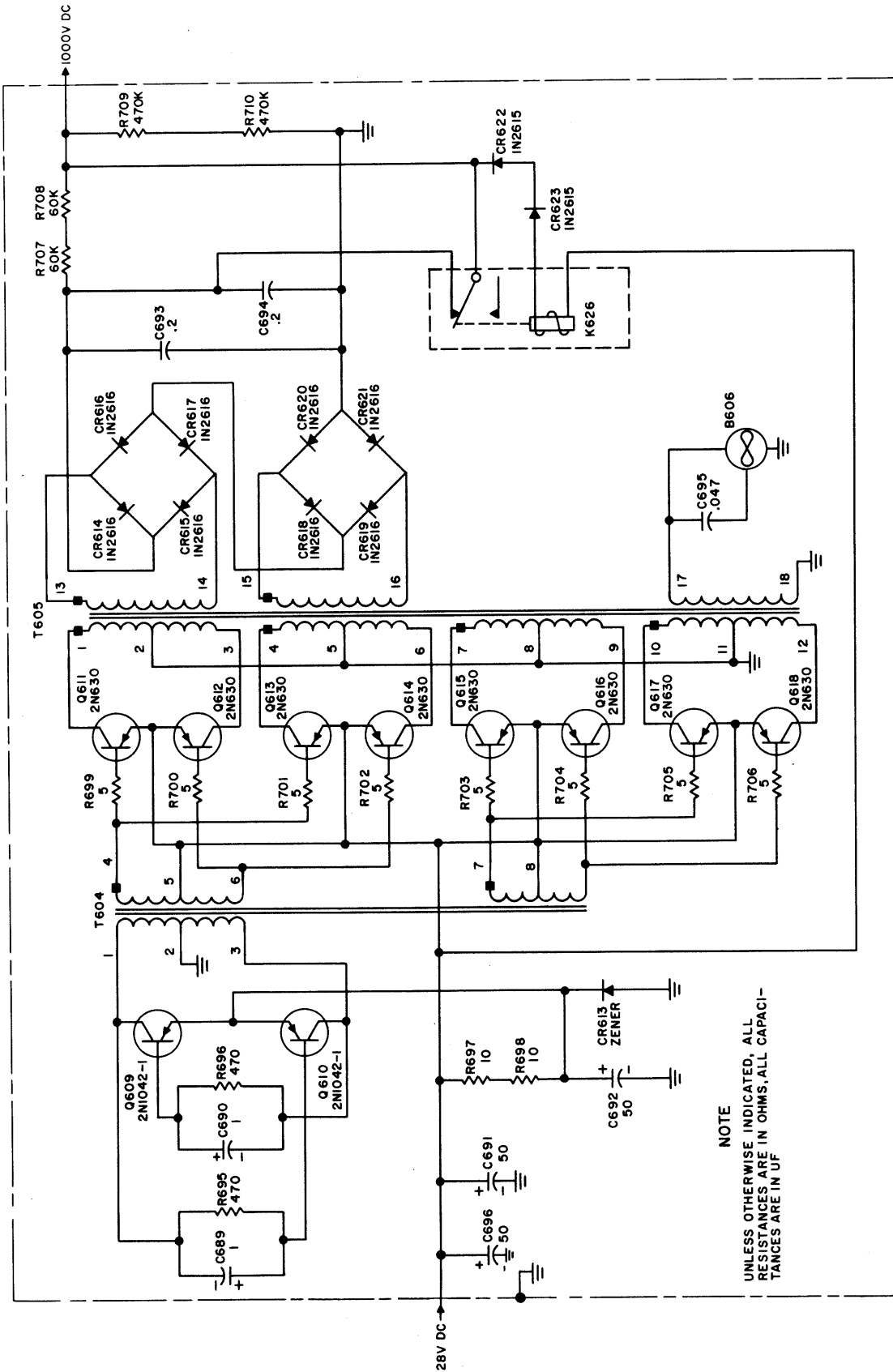

TM5820-335-35-18

Figure 1-63. Transistor-type, high-voltage power supply, complete schematic diagram.

voltage at base b2 to the supply voltage (+27.5 volts). Since the emitter voltage of transistor Q101 is nearer the voltage of base b1 than that of base b2, transistor Q101 cannot conduct, and capacitor C101 slowly discharges through resistor R101. Normally, the discharge will not progress to the point where transistor Q101 can conduct, because the voltage at the base of transistor Q1 (Q2 in PS601) drops to a low value during each conducting period. However, if an overload occurs, oscillations in the power oscillator circuit stop, and capacitor C101 continues to discharge until the voltage between emitter and base b1 of transistor Q101 increases to the point where transistor Q101 conducts (about 2 seconds), and the start module generates another pulse. Starting pulses continue to be generated until the overload condition is relieved and normal oscillations resume.

#### 1-54. Low-Voltage Transistor-Type Power Supply PS601 Operation (fig. 1-65)

*a. General.* In Radio Transmitter T-195B/GRC-19 on Order No. 4096-PP-60, a low-voltage transistor-type power supply is used in place of the low-voltage dynamotor unit and other low-voltage transistor-type power supplies. This power supply is interchangeable with the dynamotor and previous transistor power supplies. The PS601 consists of a 400-cps multivibrator oscillator, a frequency control circuit, two rectifier and filter circuits, and a cooling fan circuit. These circuits have been molded into six modules; start module Z1, frequency control module Z2, transformer module Z3, fan module Z4, 45-volt output module Z5, and 250-volt output module Z6, to which are added the other components required to make the unit operational.

##### *b. Simplified Operation.*

(1) The 27.5-volt dc input voltage is applied to start module Z1, frequency control module Z2, and the power oscillator circuit consisting of transformer T301, transistors Q1 and Q2, and resistors R1 and R2. Capacitor C201 filters the input voltage to the power supply. Oscillations are started by a pulse from start module Z1; the frequency of oscillations is controlled by frequency control module Z2. During oscillation, transistors Q1 and Q2 conduct alternately, and generate a square-wave alternating current in the primary windings of transformer T301. Resistors R1 and R2 limit current to the base terminals of transistors Q1 and Q2. The secondary

windings of transformer T301 are connected to various circuits to develop the required output voltages of the power supply and to supply excitation for motor B401 in fan module Z4.

(2) Voltage (400-cps square-wave) from T301 secondary winding, terminals 4 and 5, is applied to fan module Z4. This module contains split-phase blower motor B401 and phase shifter capacitor C401. The fan module provides an axial flow of cooling air through the power supply to cool the components. The output of the same winding of T301 is also applied to a filter network consisting of inductors L301 and L302 and capacitors C502 and C503. The network removes the harmonic content of the square-wave voltage and develops a sine-wave, 115-volt, 400-cps ac output. One side of the ac output is connected to the common ground lead of the power supply (black), and the other side is connected to the 115V AC output lead (green).

(3) The 250-volt dc voltage is developed in 250-volt output module Z6. This module contains full-wave bridge rectifier CR601 through CR604, filter capacitor C601, and bleeder resistor R601. The T301 secondary winding, terminals 8 and 9, is connected to the full-wave bridge rectifier. The rectified voltage is filtered by capacitor C601 and applied across bleeder resistor R601. The negative output from the module is connected to the common ground lead of the power supply (black), and the positive output is connected to a +250 VDC output lead (red).

(4) The 45-volt dc voltage is developed in 45-volt output module Z5. This module contains full-wave bridge rectifier CR501 through CR504, output filter capacitor C501, and bleeder resistor R501. The T301 secondary winding, terminals 6 and 7, is connected to the full-wave bridge rectifier. The rectified voltage is filtered by capacitor C501 and applied across bleeder resistor R501. The positive output is connected to the common ground lead of the power supply (black), and the negative output is connected to -45 VDC output lead (blue).

##### *c. Detailed Operation.*

(1) When 27.5 volts dc is applied to the low-voltage power supply circuits, the charging current of capacitor C101 causes unijunction transistor Q101 to conduct heavily from emitter to base b1. This current flows into the base of transistor Q102, causing Q102 to conduct. A large pulse is thus developed at the base of transistor Q2, driving transistor Q2 into conduction and initiating oscillation in the power oscillator circuit.

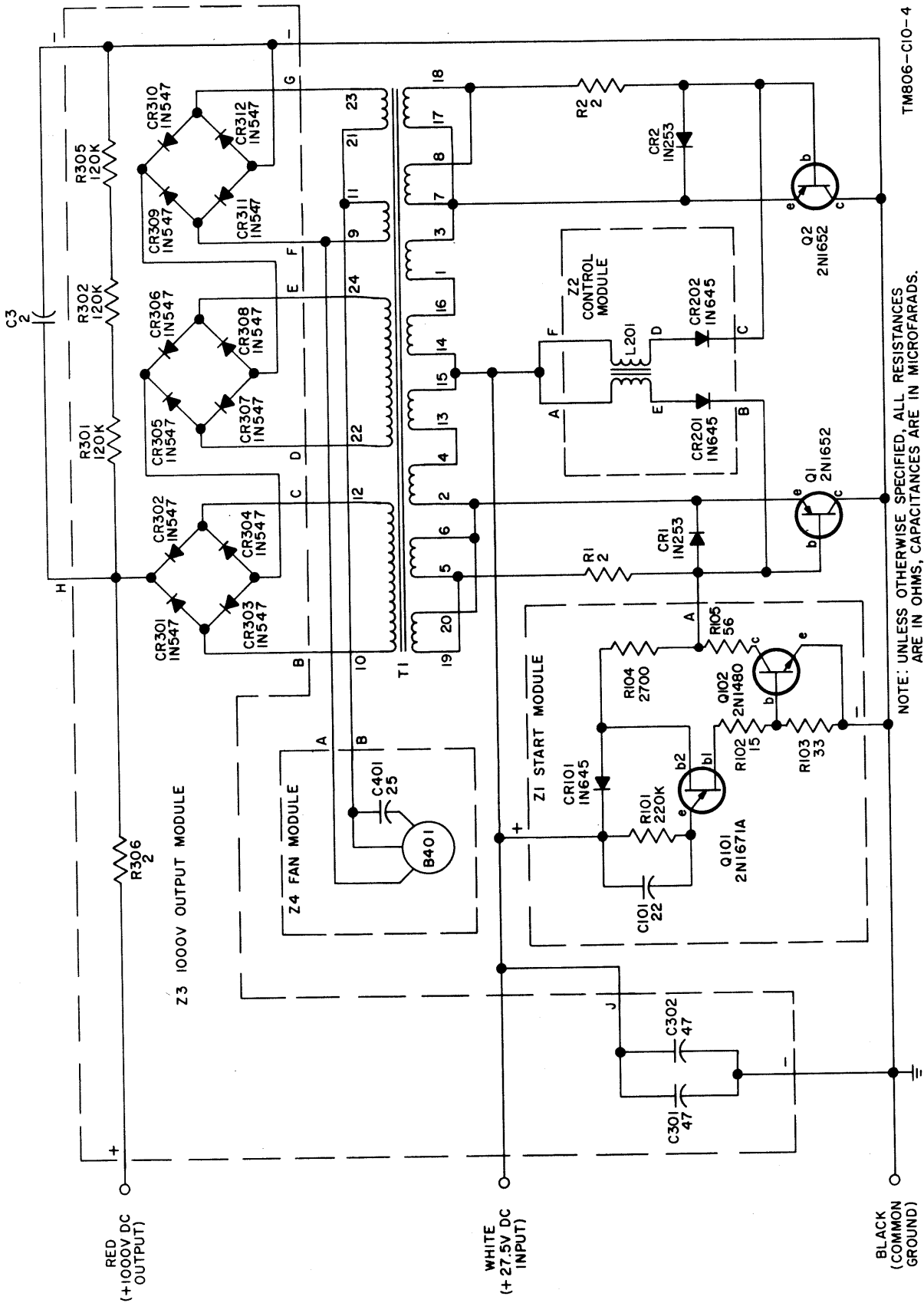

Figure 1-64. High-voltage power supply PS602, schematic diagram.



(2) The power oscillator circuit, consisting of transistors Q1 and Q2, current-limiting resistors R1 and R2, and transformer T301, is essentially a 400-cps multivibrator. Application of a pulse from start module Z1 causes transistor Q2 to conduct; the emitter current of transistor Q2 flows through the T301 primary winding, terminals 14 and 15, and induces voltages in all other windings of the transformer. The voltage induced in the primary winding, terminals 16 and 17, connected between base and emitter of transistor Q2 is regenerative, and transistor Q2 is driven sharply into saturation. During this period, transistor Q1 is maintained at cutoff because of the polarity of the induced voltage in the T301 primary winding, terminals 10 and 11, applied between its base and emitter. This condition is maintained for approximately 1.25 milliseconds (the period of one-half cycle at 400 cps). The switching action of the power oscillator circuit is controlled by frequency control module Z2.

(3) The 27.5-volt dc input voltage to frequency control module Z2 is filtered, reduced in value, and regulated by the circuit composed of resistor R201, capacitor C201, and Zener diode CR201. The regulated dc voltage is applied by a resistor-capacitor network composed of resistors R203 and R204, and capacitor C202. Capacitor C202 charges through the resistors and, after approximately 1.25 milliseconds, the voltage across C202 reaches the level required to drive unijunction transistor Q202 into conduction. Capacitor C202 partly discharges through transistor Q202, and develops a pulse at base b1 of transistor Q202 that is applied through diode CR205 to the base of transistor Q204, causing transistor Q204 to conduct. Capacitor C206, which had initially charged through diode CR207 to 5 volts, discharges through transistor Q204, resistor R2, and the T301 primary winding, terminals 16 and 17, driving transistor Q2 into cutoff. The rapid fall in Q2 emitter current through the T301 primary winding, terminals 14 and 15, induces a forward-biasing voltage in the T301 primary winding, terminals 10 and 11, connected be-

tween base and emitter of transistor Q1, and Q1 conducts. The flow of emitter current through T301 primary winding, terminals 12 and 13, induces a regenerative voltage in the winding connected between emitter and base of transistor Q1, and Q1 is driven sharply into saturation.

(4) When transistor Q1 is saturated, its base-emitter voltage drops rapidly toward zero. As the voltage falls, current flows through capacitor C203 and diode CR202 from the base of transistor Q201, which is driven into conduction. When transistor Q201 conducts, it completely discharges capacitor C202, and transistor Q202 is cut off. Again capacitor C202 begins to charge through resistors R203 and R204 and, after approximately 1.25 milliseconds, the charge of capacitor C202 is sufficient to drive unijunction transistor Q202 into conduction. The pulse developed at base b1 of transistor Q202 is applied through diode CR204 to the base of transistor Q203, driving Q203 into conduction. Capacitor C205, which had initially charged through diode CR206 to 5 volts discharges through transistor Q203, resistor R1, and the T301 primary winding, terminals 10 and 11, driving transistor Q1 into cutoff. The rapid fall of Q1 emitter current through the T301 primary winding, terminals 12 and 13, induces a forward-biasing voltage in the T301 primary winding, terminals 16 and 17, causing transistor Q2 to conduct again, and completing one cycle of operation in the power oscillator circuit. The switching action in the oscillator circuit is repeated at a rate determined by the time constant of resistors R203 and R204 and capacitor C202 in frequency control module Z2, and a 400-cps square wave is developed in the secondary windings of transformer T301. Frequency control module Z2 prevents oscillation in the power oscillator circuit at frequencies appreciably above 400 cps.

(5) Operation of start module Z1 is identical with the operation of start module Z1 in high-voltage power supply PS602. For detailed operation theory, refer to paragraph 1-53 c (3). The theory is the same except that Q2 is the pulsed oscillator transistor instead of Q1.



## CHAPTER 2

### TROUBLESHOOTING

---

#### Section I. GENERAL TROUBLESHOOTING INFORMATION

##### WARNING

When servicing the transmitter, avoid contact with the power supply and plate circuits. The high voltages present in these circuits can cause injury or death.

#### 2-1. General Instructions

The direct support, general support and depot maintenance procedures in this manual *supplement* the procedures described in the organizational maintenance manual. The systematic troubleshooting procedure, which begins with the operational and sectionalization checks that can be performed at an organizational level, is carried to a higher level in this manual. Sectionalization, localizing, and isolating techniques used in the troubleshooting procedures are much more advanced. Section II provides interunit troubleshooting procedures to be performed by direct support maintenance facilities; sections III through chapter 3, section I describes *intra-unit* (within the unit) organizational maintenance localizing and isolating procedures.

#### 2-2. Organization of Troubleshooting Procedures

*a. General.* The first step in servicing a defective transmitter is to sectionalize the fault. Sectionalization means tracing the fault to a major component responsible for the malfunction of the transmitter. The second step is to localize the fault. Localization means tracing the fault to a defective part responsible for the abnormal condition. Some faults, such as burned-out resistors, arcing and shorted transformers can often be located by sight, smell and hearing. Loose connections or broken terminals are also often found by visual inspection. The majority of faults, however, must be located by checking voltages and resistances.

*b. Sectionalization.* Listed below is a group of tests arranged to reduce unnecessary work and to aid in tracing trouble in a defective transmit-

ter. To be effective, the procedure should be followed in the order given. *Remember that the servicing procedures should cause no further damage to the transmitter.* The first step is to locate the unit or units of fault by the following methods:

(1) *Visual inspection.* The purpose of visual inspection is to locate faults without testing or measuring circuits. It is often possible to locate troubles within an equipment by inspecting the condition of the wiring and parts for visible evidence of failure. Meter readings or other visual signs should be observed and an attempt made to sectionalize the fault to a particular unit. Visual inspection avoids additional damage to the transmitter by preventing improper servicing methods. This inspection can be carried out quickly and simply and can yield rapid results; therefore, it is the first to be applied in the troubleshooting procedure.

(2) *Operational tests.* Operational tests frequently indicate the general location of trouble. In many instances, the tests will help in determining the exact extent of the fault. The operational check list (TM 11-5820-335-10) is a good operational test. By using the information gained from observing the symptoms of faulty operation, it is sometimes possible to determine the exact nature of the fault.

*c. Localization.* After the trouble has been sectionalized (*b* above), the methods listed in (1) and (2) below will aid in localizing the trouble to a stage or module in the suspected unit.

(1) *Troubleshooting chart.* The meter indications, or lack of meter indications, and operational checks provide a systematic method of localizing trouble to a stage or module. The trouble symptoms listed in the troubleshooting

chart (para 2-3) provide additional information for localizing troubles.

(2) *Intermittents*. In all these tests, the possibility of intermittents should not be overlooked. If present, this type of trouble may be discovered by tapping or jarring the subchassis or parts under test. It is possible that the trouble is not in the transistor itself, but in the installation (mounting, antenna, ground auxiliary equipment, or vehicle), or the trouble may be due to external conditions; therefore, test the installation if possible.

d. *Isolation*. After the trouble has been localized (c above), the methods in (1) and (2) below will help in isolating the trouble to defective circuit elements.

(1) *Voltage measurements*. When measuring voltages of transistorize circuits, use tape

or sleeving (spaghetti) to insulate the entire test prod except for the extreme tip. A momentary short circuit can ruin the transistor. Use the same or equivalent electronic multimeter (VTVM) specified on the voltage and resistance diagram (para 2-10).

(2) *Resistance measurements*. Make resistance measurements in this equipment only as directed on voltage and resistance diagrams or charts, otherwise the indication obtained will be inaccurate.

### 2-3. Troubleshooting Data

Take advantage of the material supplied in this manual. It will help in the rapid location of faults. Consult the following troubleshooting data:

Fig. No. Para No.	Description
Fig. 7. TM 11-5820-335-20	Radio Transmitter T-195/GRC-19, filament circuit block diagram. Radio Transmitter T-195/GRC-19, tube location.
1-42	Hermetically sealed receiver antenna relay K615 (used in T-195B/GRC-19 on Order No. 4096-PP-60), schematic diagram.
1-46	Hermetically sealed autotune relay K610 (used in T-195B/GRC-19 on Order No. 4096-PP-60), schematic diagram.
1-52	Hermetically sealed autotune relay K608 (used in T-195B/GRC-19 on Order No. 4096-PP-60), schematic diagram.
1-53	Hermetically sealed lv relay K602 (used in T-195B/GRC-19 on Order No. 4096-PP-60), schematic.
1-57	High-voltage power supply A1200, schematic diagram.
1-58	High-voltage power supply A1200 (MOD 1), schematic diagram.
1-64	High-voltage power supply PS602, schematic diagram.
1-65	Low-voltage power supply PS601, schematic diagram.
2-1	Fabrication of test cables.
2-11	DC resistances of transformers, coils, and motors.
2-12	DC resistance of receptacles and connectors.
2-3 through 2-48	Views of transmitter subchassis, showing locations of parts.
1-60	Exhaust blower B602, transistor type, schematic diagram.
1-61	PA Blower B202, transistor type, schematic diagram.
1-62	Low voltage power supply, transistor type, schematic diagram.
1-63	High voltage power supply, transistor type, schematic diagram.
2-33	High-voltage power supply PS602, terminal board measurements.
2-34	Low-voltage power supply PS601, terminal board measurements.
2-35	Master oscillator subchassis, schematic diagram.
2-36	Exciter subchassis, schematic diagram.
2-37	Power amplifier subchassis, schematic diagram.
2-45	Modulator subchassis, schematic diagram.
2-46	Discriminator subchassis, schematic diagram.
2-47	Antenna network servo amplifier subchassis, schematic diagram.
2-48	Antenna tuning capacitor subchassis, schematic diagram.
2-49 through 2-56	Variable inductor subchassis, schematic diagram.
2-57 and 2-58	Main frame, schematic diagram.
2-59 through 2-63	Subchassis interconnection cabling diagram.
2-2	

Fig. No. Para No.	Description
2-64	Radio Transmitter T-195/GRC-19, schematic diagram.
2-83	High-voltage power supply A1200, top view.
2-65	High-voltage power supply A1200, side view.
2-66	Transistor-type pa blower B202, terminal board measurements.
2-67	Transistor-type exhaust blower B602, terminal board measurements.
2-68	Transistor-type low voltage power supply, terminal board measurements.
2-69	Transistor-type high voltage power supply, terminal board measurements.
2-70	High-voltage power supply A1200, bottom view.
2-71	High-voltage power supply A1200 (MOD 1), side view.
2-72	High-voltage power supply A1200 (MOD 1), bottom view.
2-73	High-voltage power supply PS602, top view, cover removed.
2-74	High-voltage power supply PS602, bottom view, cover removed.
2-75	Low-voltage power supply PS601, top view, cover removed.
2-76	Low-voltage power supply PS601, bottom view, cover removed.
2-77	Views of main frame showing location of parts.
2-78	Tube-socket voltage and resistance diagrams.
2-79	Terminal board voltage and resistance readings.
2-80	High-voltage power supply, voltage and resistance diagram.
2-81	High-voltage power supply (MOD 1), voltage and resistance diagram.
2-82	Terminal board voltage and resistance measurements.

## 2-4. Test Equipment Required

a. The following chart lists test equipment for troubleshooting Radio Transmitter T-195/GRC-19. The technical manuals associated with the test equipment are also listed.

### CAUTION

The power supply circuit is transistorized. If any equipment item does not have an isolation transformer in its power supply circuit, connect one in the power input circuit. A suitable transformer is identified by FSN 5950-356-1779.

(1) Never connect test equipment (other than multimeters and VTVM'S) outputs directly to a transistor circuit; use a coupling capacitor.

(2) Make test equipment connections with care so that shorts will not be caused by exposed test equipment connectors. Tape or sleeve (spaghetti) test prods or clips to leave as little exposed as needed to make contact to the circuit under test.

(3) The equipment battery (or its equivalent) normally used is recommended as the

source of power when servicing transistorized equipment. *Observe battery polarity.* Polarity reversals may damage the transistors or electrolytic capacitors in the circuit. If a battery eliminator is used in place of the battery normally used with the equipment, it must have good voltage regulation and low a-c ripple. Good regulation is important because the output voltage of the battery eliminator (which has poor regulation) may exceed the maximum voltage rating of the transistors in the equipment being tested. A battery eliminator that has poor a-c filtering will create a false indication of poor filtering in the equipment being tested.

(4) The transistorized equipment must be turned off before switching the battery eliminator on or off. The transient voltages, created by switching the battery eliminator on and off, may exceed the "punch-through" rating of the transistors. Also, make sure that a normal load (such as a speaker for a receiver) is connected to the transistorized equipment before applying power.

b. A list of the nomenclature for test equipment is given below. A common name is indicated after each item.

Test Equipment	Technical Manual	Common Name
Electron Tube Test Set TV-7/U, or equal	TM 11-6625-274-12	Tube Tester
Audio Oscillator TS-382/U, or equal	TM 11-6625-261-12	Audio Oscillator
Electronic Multimeter TS-505/U, or equal	TM 11-5511	VTVM
Multimeter TS-352B/U	TM 11-6625-366-15	Multimeter
Oscilloscope OS-8A/U	TM 11-1214	Oscilloscope

## Section II. INTERUNIT TROUBLESHOOTING

## 2-5. Procedures

a. When a cause of equipment failure has been sectionalized to a subchassis, a bench test of the faulty subchassis may be required to locate the trouble through voltage readings. The undersides of the subchassis are not accessible for troubleshooting when the subchassis are mounted in the transmitter; therefore it may be necessary to remove the subchassis under test and connect it to the transmitter circuits by the use of extension cables. Directions for the fabrication of the extension cables are given in figure 2-1. The type of extension needed can be determined from the chart in *b* below.

b. To prepare a subchassis for bench testing, remove the subchassis from the transmitter according to the instructions contained in paragraph 3-1. *Be careful to avoid the possibility of disturbing the synchronization of the gear train with the master-oscillator subchassis, exciter subchassis, and power-amplifier subchassis.* Connect the extension cables between the transmitter and subchassis according to the chart below.

## CAUTION

When the subchassis are operated outside the transmitter, dangerous voltages are exposed at the tube-socket pins and other points on the underside of the chassis. Observe the rules for servicing in the presence of high voltage to prevent possible injury.

Subchassis	Cable No.	Connect between
Master oscillator -----	4	P802—J617
Exciter -----	2	P101—J607
Power amplifier -----	2	P201—J608
Discriminator -----	4	P302—J609
Antenna tuning capacitor -----	1	P1001—J610
Variable inductor -----	3	P1101—J612
Modulator -----	3	P401—J606
Antenna-network servo-amplifier -	2	P901—J611

## c. General Precautions.

When a transmitter is to be serviced, observe the following precautions very carefully:

(1) When the transmitter is removed from the case, cabinet, or rack for servicing, connect an adequate ground to the main frame and to any subchassis operated outside the main frame before connecting the power cord.

(2) Make certain that the transmitter is disconnected from the power source or is turned off before contacting high-voltage circuits, changing connections or removing fuses.

(3) After disconnecting tuning shafts for removal of a subchassis, avoid turning the shafts or tuning controls unless necessary for troubleshooting or adjustment. Careful handling may eliminate the need for synchronization. It will be helpful to make a note of the positions of the front-panel controls because a control may be disturbed during servicing.

(4) Careless replacement of parts often makes new faults inevitable. Note the following points:

(a) Before unsoldering a part, note the position of the leads. If the part has a number of connections, tag each lead.

(b) Be careful not to damage other leads while pulling or pushing them out of the way.

(c) Do not allow drops of solder to fall into the transmitter. They may cause short circuits.

(d) A carelessly soldered connection may create a new fault. It is very important to make well-soldered joints. A poorly soldered joint is one of the most difficult faults to find.

(e) When a part is replaced in the rf circuit, it must be placed in the exact position of the original part. A part that has the same electrical value but different physical size may cause trouble in high frequency circuits. Give particular attention to proper grounding when replacing a part. Use the same ground as in the original wiring. Failure to observe these precautions may result in oscillation of the circuit or other erratic symptoms.

(5) Before taking voltage measurements or performing circuit alignments, always check the value of the input dc voltage source. The input dc voltage should be approximately 28.5 volts.

## d. Troubleshooting Notes

(1) To avoid the necessity for removing a subchassis when voltage is to be measured at a tube-socket pin, remove the tube, insert a short length of thin insulated wire having both ends bared into the desired contact, and replace the tube. Connection to the test equipment then can be made through the exposed end of the wire.

(2) Before attempting to do any kind of work on the circuits, be sure that all power to the transmitter has been turned off and that no danger from charged capacitors in the high-voltage circuits exists. Use a grounding stick, such as a metallic rod having an insulated handle, for shorting circuits to ground. The rod of the grounding stick should be attached to a copper-

braid strap with a strong alligator clip to ensure good ground contact.

(3) Before attempting to turn on the transmitter for troubleshooting, alignment, or test purposes, be sure that no violation of security or frequency assignments will occur. A dummy antenna such as shown in figure 2-2 will prevent rf radiation. The dummy antenna uses a 150-watt incandescent lamp in a porcelain-type screw receptacle. The lamp is connected in series with an 80- $\mu$ f capacitor which is rated at 15 kilovolts, dc. The dummy antenna is connected between the WHIP ANTENNA receptacle and ground.

*e. Visual Inspection*

When a transmitter is brought in from the field for checking or repair, remove its case and inspect it as follows:

**WARNING**

When servicing Radio Transmitter T-195/GRC-19, be extremely careful of exposed circuits carrying high voltages. When power to the transmitter is disconnected, some capacitors still may retain voltages of dangerous potential. Before touching exposed electrical parts after the voltage has been shut off, short-circuit the part to ground with a grounding stick having an insulated handle. **WHEN POWER TO THE TRANSMITTER IS ON, VOLTAGE AS**

**HIGH AS 1,000 VOLTS DC OR 10,000 VOLTS RF IS PRESENT IN THE CIRCUITS OF THE TRANSMITTER.**

(1) Inspect all cables, plugs, and receptacles. *Check to see that all connectors are seated properly.* This is important, because improperly seated connectors are a frequent cause of abnormal operation in equipment. Repair or replace any connectors or cables that are broken or otherwise defective.

(2) Inspect for burned insulation and for resistors that show signs of overheating. Look for wax leakage and for any discoloration.

(3) Inspect for broken connections to tube sockets, plugs, and other apparatus, as well as for defective soldered connections. Look for bare wires touching the chassis or adjoining wires.

(4) Make certain that all tubes are in their correct sockets. Inspect for loose tube pins. Replace defective tubes.

(5) Inspect fuses for correct rating and type. Check carefully for short circuits (para 2-6) whenever a blown fuse is found.

(6) Operate the tuning mechanism both manually and with the Autotune system. See that the BAND SELECTOR and TUNING CONTROL knobs turn freely. Rough operation or binding indicates a damaged tuning system or need for cleaning and lubrication (para 3-3).

(7) Check all switches and controls for ease of operation.

1. THE MULTI-CONDUCTOR EXTENSION CABLES ARE TO BE FABRICATED OF NO. 18 TO 22 GAUGE STRANDED WIRE. INSULATION MUST BE RATED AT 600V.
2. CONNECTORS SHOWN VIEWED FROM REAR.
3. CABLES TO BE LACED WITH NO.6 VINYLITE LACING CORD AS SHOWN IN INSERT.
4. MAXIMUM LENGTH OF ALL CABLES IS 24 IN.
5. CHECK CONTINUITY AFTER COMPLETING FABRICATION.
6. LABEL EXTENSION CABLES FOR IDENTIFICATION.

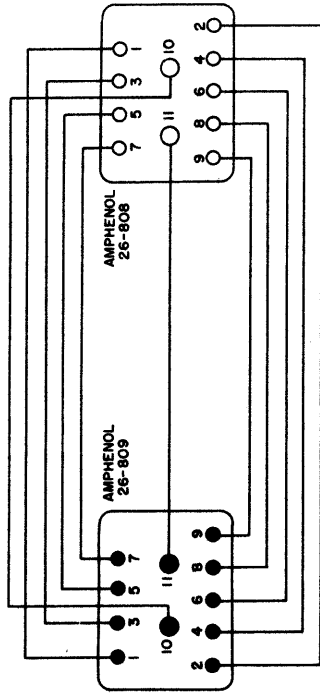
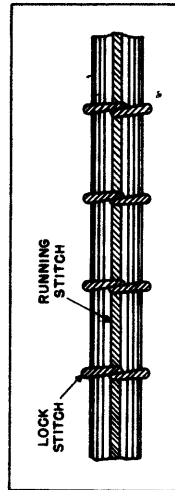

CABLE NO. 1

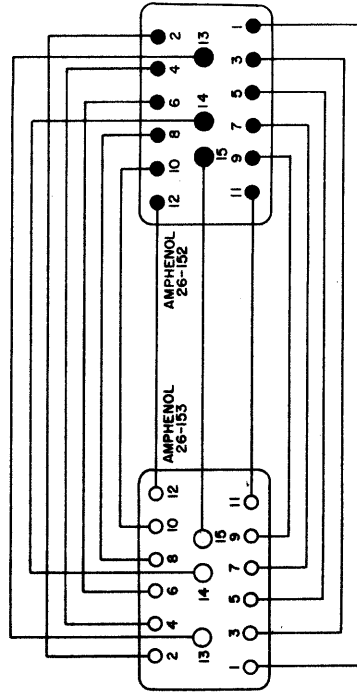

CABLE NO. 2

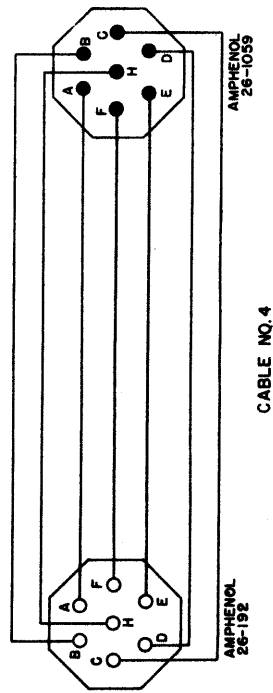

CABLE NO. 4

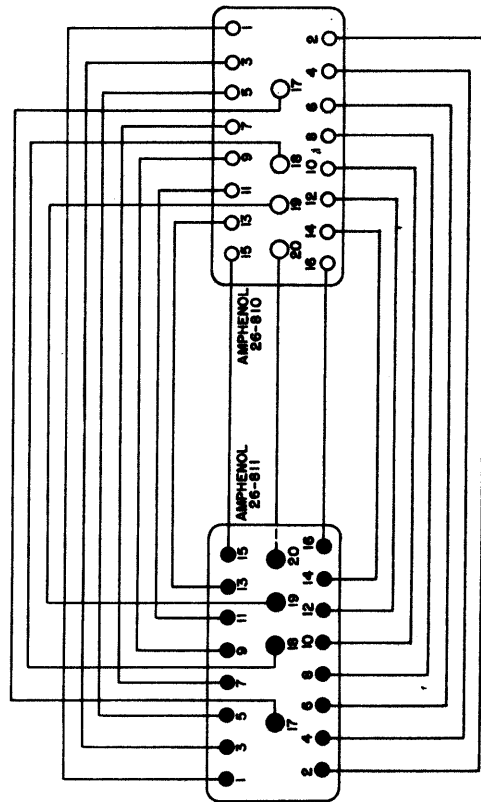

CABLE NO. 3

Figure 2-1. Fabrication of test cables.



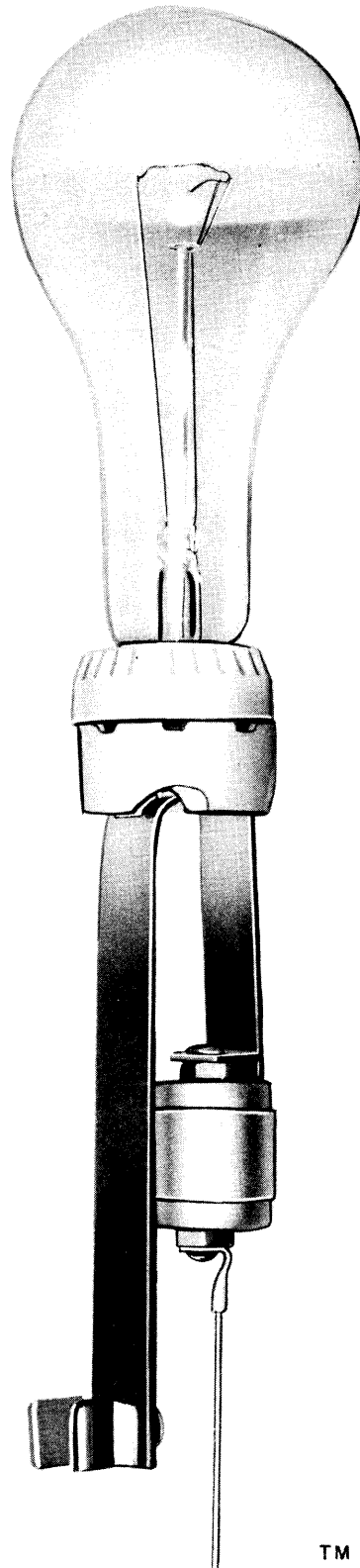

TM 806-104

*Figure 2-2. Dummy antenna.*

### Section III. UNIT TROUBLESHOOTING

#### 2-6. Checking Filament and B+ circuits for Shorts

The dc circuits of the transmitter are protected by three fuses (F601, F602, and F603). A short in the dc circuits usually will cause one of the three fuses to blow out. The three tables below give short-locating procedures for each fused circuit. When checking for shorts, use the table which corresponds to the blown fuse.

##### a. General.

(1) Use a 20,000 ohms-per-volt meter for making resistance measurements. Calibrate the meter carefully; readings should not vary more than 10 percent from the readings given in the charts.

(2) Measurements are made between the check point and ground, unless otherwise stated.

(3) Return the equipment to its original condition after each check. In the *Additional checks* column, return the equipment to the condition stated in the first column.

(4) If an abnormal reading is obtained, and the parts listed under *probable trouble* are not defective, consult the schematic diagrams to locate the trouble in the circuit in which the abnormal reading was obtained.

b. *Preparatory Procedures.* Make the following preparations before checking.

(1) Remove all external connections from the transmitter.

(2) Remove the transmitter from its case.

(3) Calibrate the test meter carefully, by means of the *zero adjust* control.

c. Checks for F601 (fig. 1-51).

Equipment conditions	Check point	Normal resistance (in ohms)	Probable trouble	Additional checks	Normal resistance (in ohms)	Probable trouble
F601 removed. S606 to OFF	Xmtr side of XF601	Infinity	K608, S606 or S608 defective. Line short, F601 to K608-2.			
Any condition	Term. F1 of B601	2	B601 defective.			
Disconnect P201, P101, P1001, P401, P802; S606 to OFF. DIAL DIM to OFF. TEST METER to PA GRID.	J607-11	0.5	B602, S610, K605, K607 or C622 defective.			
	J608-18	2.1	K616, K613, C632, K610, or C658.			
	J607-1, 2, 3, and 4	200 at one or more term.	K613 defective.			
	J610-3	200	K616 defective.			
	Term. 1 of K610	.55	K610 or R619 defective.			
	J617-C	.55	R611 defective.			
	P802-C	6	Short in no filament circuit.			
	P201-13	14	B202, C249, C209, C210 or S202 defective.			
	Connect between P201-13 and P201-1.	280	K203 defective.	P201-13. Connect P101.	13	K201 defective
	P101-14	58	Short in exciter filament circuit.	Note. If BAND indicator reads in 6 to 20 mc range, disconnect P101 and read resistance between P201-6 and P201-13 to check K201. Resistance should be 700 ohms.		
	P401-14	400	K403 or K402 defective.			
	J601-F	Infinity	S603, S606, Z601 or K605 defective.			
	Connect between P401-18 and P401-20.	26, 26	Short in modulator filament circuit. (V401, V402, V403, V404, V406 or V407.)			
	J606-8	Infinity	B603 short to ground	S606 to CALIB S606 to CW	250 100	K602 defective. C644 or K603 defective.
Disconnect P401. Close cabinet interlock S611. S606 to OFF.	Connect test leads between J606-8 and junction of R605 and B603.	4	R605 or B603 defective.			

Note. If F601 blows during homing cycle, check K604.

d. Checks for F602 (fig. 1-51 and 2-72)

Equipment conditions	Check point	Normal resistance (in ohms)	Probable trouble	Additional checks	Normal resistance (in ohms)	Probable trouble
Disconnect P901, P1101, ICE SELECTOR S606 to CW.	J612-11 Connect test leads between P1101-14 and P1101-15.	200 15	K617 defective. B1102 or R1101 defective.			
Remove F602	P1101-15 E602-1	Infinity 0.3*	B1102 short to ground. D601 or low-voltage transistor-type power supply is defective.			
Disconnect P601, P1101, P1001, and P201.	J611-5  Connect between P1101-20 and P1101-18. P1001-9 P201-12 P901-5	12  160 160 160 4.4K	D601 or low-voltage transistor-type power supply is defective. B1101 is defective. B1001 is defective. B201 is defective. Defect in T901 primary circuit (fig. ).			
Disconnect P101	J607-6	55	D601 or low-voltage transistor-type power supply is defective.			
Disconnect P101, P201, P401, P901 and P820.	Connect test leads between P101-6 and P101-5. J606-11  Connect test leads between J606-7 and J606-11. P901-11 J611-8 J611-7 V401-6 (pull tube) P401-11 P802-A P101-13 P201-9	150K 90  50K Infinity 250 250 150 K Infinity Infinity 370K+ 1.1 meg	R119 defective. D601 or low-voltage transistor-type power supply is defective. R626 defective. C908, C918 defective. B1101 defective. B1001 defective. C409, R409, R415 or R414 defective. C405 defective. C810 defective. C146, C135, C128 or C143 defective. C243, C244, R204 or B201 defective.			

\* Resistance varies with the position of the dynamotor armature.

e. Checks for F603 (figs. 1-16, 1-26, 1-41 and 1-51).

Equipment conditions	Check point	Normal resistance (in ohms)	Probable trouble	Additional checks	Normal resistance (in ohms)	Probable trouble
Remove F603	E603-1	0.3 4 in A model.	D602 or high-voltage power supply A1200 or PS602 defective.			
Disconnect P205, P206, and P201.	P205	Infinity	C203, C202, C250, or C251 defective.			
	J618-B	180* 40K in A model.	D602 or high-voltage power supply A1200 or PS602 or C659 defective.			
	Connect between P201-5 and P205.	Infinity	C204 defective.			

\* Resistance varies with the position of the dynamotor armature.

**2-7. Operational Test**

Operate the equipment as described in the operational checklist (para 27 TM 11-5820-335-10). This checklist is important because it frequently aids in sectionalizing the trouble without the need for further testing. Check for overheated parts, faulty controls, and intermittent operation. Observe closely the readings of the test and audio level meters.

**2-8. Localizing and Isolating Troubles**

The following chart is supplied as an aid in locating trouble in the radio transmitter. It lists the symptoms that the repairman observes, either visually or audibly. The chart also indicates how to localize trouble quickly to the defective stage, and to defective parts within the Autotune and/or automatic tuning system. When the trouble

has been localized to a stage or circuit, a tube check, and voltage and resistance measurements of that stage or circuit, should be sufficient to isolate the defective part.

**CAUTION**

When testing transistorized units in the A model, be very careful in the application of test prods to make voltage measurements. The momentary short circuit caused by the slip of a test prod can permanently damage a transistor. If soldering is done in a transistorized unit, use a heat sink device, such as a long-nosed pliers, to grip the wire between the soldering point and a transistor to conduct excess heat away from the transistor. In all instances, use the lowest wattage soldering iron practicable.

Symptom	Probable cause	Correction
1. Neither blower starts when switching SERVICE SELECTOR switch from OFF to VOICE/FSK.	Filament fuse F601 is defective -----	Replace F601. If replacement fuse burns out, check for a short circuit in the 24-volt line which supplies the transmitter filaments, dial lights, blowers, Autotune motor, ec. Refer to figure 1-51.
	Power cable is defective or has not been properly installed.	Check continuity of power cable. Determine that the power cable plug has been seated adequately to the front panel power receptacle. Check connections of power cable to power source.
	Defective blowers -----	Check B602 and B202 for proper operation.
	Variable inductor plug, P1101, not fully inserted into chassis receptacle, or the interlock connection between pins 3 and 13 of P1101 is open.	Check continuity between pins 3 and 13 of P1101. Fully insert plug into chassis receptacle.
	Antenna tuning capacitor plug P1001 is not fully inserted into chassis receptacle, or the interlock connection between pins 5 and 7 of P1001 is open.	Check continuity between pin 5 P1001 and ground. Fully insert plug into chassis receptacle.
	Power amplifier plug P201 is not fully inserted into chassis receptacle or the interlock connection between pin 14 of P201 and ground through S202 is open.	Check continuity between pin 14 of P201 and ground, check S202, and fully insert the plug into the receptacle.
	Defective filament start relay (K608) -----	Check relay; replace if defective.
2. Test meter does not indicate normal on LINE VOLTAGE scale.	Power source voltage is defective -----	Check supply voltage with another meter. If proper indication is obtained, replace the front panel test meter.
	High-resistance connections between power source and transmitter. R618 or R614 defective -----	Clean and tighten connections. Check resistors, and replace if necessary.
3. Low-voltage dynamotor or low-voltage transistor-type power supply does not	F602 defective -----	Replace F602. If replacement fuse burns out, check for a short circuit in the 24-volt input circuits of the

Symptom	Probable cause	Correction
<p>3. Continued within two minutes after SERVICE SELECTOR switch has been turned from OFF to CALIBRATE.</p>	<p>Cabinet interlock S611 is defective or not closed.</p> <p>K602 is not energized due to defective time delay relay.</p>	<p>dynamotor. D601 or low-voltage transistor-type power supply in accordance with paragraph 2-6.</p> <p>Check continuity of S611. Check panel-to-case fit by means of 16 screws at edges of front panel.</p> <p>Check K602 and K403, and if necessary, replace. Determine that the modulator plug, P401, is secure.</p> <p>Check continuity of connections from P401 to K403 contacts and heater coil.</p>
<p>4. Autotune does not operate when changing channels.</p>	<p>Autotune motor B601 defective-----</p>	<p>Check and replace if defective.</p>
<p>5. BAND SELECTOR and TUNING CONTROL knobs keep reversing after PRESET CHANNELS switch is moved to new position.</p>	<p>The common clip of S604 front (PRESET CHANNELS switch) is not connected to ground when the SERVICE SELECTOR switch is in any position other than OFF due to a broken wire or dirty contacts of the SERVICE SELECTOR switch.</p>	<p>Check and repair or clean, as necessary.</p>
<p>6. BAND SELECTOR and TUNING CONTROL knobs are left unlocked at conclusion of Autotune cycle.</p>	<p>Defective Autotune relay K610-----</p>	<p>Check; replace if defective.</p>
<p>7. Autotune relay K610 energized on all channels due to constant ground at term. 1.</p>	<p>Autotune heads are out of synchronization.</p>	<p>Check open-circuit seeking switches S605 and S604; check S617 and K610.</p> <p>Refer to paragraph 3-6.</p>
<p>8. Antenna output capacitor switch, S612, rotates but does not position correctly to correspond with the setting of the BAND SELECTOR.</p>	<p>Channel-indicating dial hub not properly positioned on the Autotune control head shaft, resulting in momentary grounding of portions of S605, which is mounted to the rear of the hub on the same shaft.</p>	<p>Loosen setscrew which tightens channel-indicating dial hub to Autotune control head shaft and reposition dial hub slightly forward.</p>
<p>9. Antenna output capacitor switch S612 does not rotate, regardless of the position of the BAND SELECTOR.</p>	<p>Autotune system is not properly synchronized.</p> <p>Exciter band switch not correctly synchronized with the BAND SELECTOR.</p>	<p>Synchronize Autotune system as outlined in paragraph 3-6.</p> <p>Refer to paragraph 3-8.</p>
<p>10. Antenna output capacitor switch S612 does not rotate, regardless of the position of the BAND SELECTOR.</p>	<p>Defective wiring between S101C and C614A. Contacts on switches bent or dirty.</p>	<p>Check and repair. Clean or adjust switches if necessary.</p>
<p>10. Antenna tuning capacitor and variable inductor fail to accomplish their homing cycle.</p>	<p>P101 not securely connected to J607 -----</p> <p>K613 does not operate -----</p>	<p>Check and secure properly.</p> <p>Check the energizing circuit of K613. This circuit consists essentially of K613, S614A, and S101C.</p> <p>Check and repair or replace.</p>
<p>10. Antenna tuning capacitor and variable inductor fail to accomplish their homing cycle.</p>	<p>Defective brushes on motor B603 or defective motor.</p> <p>Defective +24-volt supply to motor B603.</p>	<p>Check K609 and replace if defective.</p>
<p>10. Antenna tuning capacitor and variable inductor fail to accomplish their homing cycle.</p>	<p>Ground connection to B603 through K613 and S606A defective.</p>	<p>Check K613 and replace if defective. Check ground path through S606B.</p>
<p>10. Antenna tuning capacitor and variable inductor fail to accomplish their homing cycle.</p>	<p>Pin 4 of power amplifier plug P201 not momentarily grounded between bands of BAND SELECTOR.</p>	<p>Check continuity between pin 4 of P201 and ground while rotating the BAND SELECTOR and determine that this pin is momentarily grounded <i>between</i> bands. If not, check the synchronization of power-amplifier band switch</p>

Symptom	Probable cause	Correction
<p>10. Continued</p> <p>11. The dc motor (B1102) operates the variable inductor, but the homing cycle is never completed. That is, the ribbon continues to wind and unwind from the ceramic coil form.</p> <p>12. The dc motor, B1102, does not operate to start the homing cycle of the variable inductor, regardless of the position of the transmitter BAND SELECTOR.</p> <p>13. The dc motor (B1102) operates the variable inductor, but the motor fails to reverse direction when the ribbon is within about three turns of being completely unwound from the ceramic coil form. This may</p>	<p>The variable capacitors on the antenna tuning capacitor are not at minimum capacitance. This usually is caused by lack of synchronization between the linear switch, S1002, and the variable capacitor.</p> <p>Continuous short circuit between pin 4 of power-amplifier plug P201 and ground regardless of the position of the BAND SELECTOR. This pin should be grounded only between bands on the BAND SELECTOR.</p> <p>K616 remains energized due to the fact that spring contact 3 of S1003 remains grounded even though linear switch S1002 is in its lowest detent position.</p> <p>K616 remains energized due to the fact that pin 6 of variable inductor plug P1101 never finds an open circuit to ground regardless of the position of S1101B front.</p> <p>No dc voltage at pin 1 of the antenna-network servo amplifier plug, P901, when the antenna tuning capacitor should perform its homing cycle.</p> <p>Antenna-network servo amplifier plug P901 not properly inserted.</p> <p>Open circuit between pin 5 of V902 and terminal 4 of B1001.</p> <p>Defective antenna-network servo amplifier due to failure of V901, V902, or G901.</p> <p>Defective servo motor B1001 -----</p> <p>Antenna tuning capacitor plug P1001 not completely inserted.</p> <p>No dc voltage is applied to dc motor B1102 in any position of the BAND SELECTOR.</p> <p>Worn brushes on dc motor B1102 -----</p> <p>Defective dc motor B1102 -----</p> <p>Terminal 1 of K617 is not being grounded through S1101A (front) and S606, when approximately three turns of ribbon remain on the ceramic coil form.</p>	<p>shaft with the BAND SELECTOR. Check operation of the cam-driven contacts which connect to pin 4 of P201 and ground.</p> <p>Synchronize linear switch S1002 with the variable capacitors by rotating the gear of B1001 with a finger until S1002 moves in a direction away from minimum capacitance.</p> <p>Check synchronization between power-amplifier band switch shaft and BAND SELECTOR. Check operation of cam-driven contacts which connect to pin 4 of P201 and ground.</p> <p>Adjust the position of S1003 so that when linear switch S1002 is in its position for minimum capacitance, it operates the switch, thereby removing the ground from spring contact 3 of S1003.</p> <p>Check to determine whether all circuits between S1101B front and S101E front are connected as they should be, and that no inadvertent ground of pin 6 of P1101 exists.</p> <p>The operation of K616 should apply a dc potential through R620 to pin 1 of the antenna-network servo amplifier. Check to determine whether these component parts and circuits are performing this function.</p> <p>Check to determine whether P901 is properly inserted.</p> <p>Check continuity of circuit and repair if necessary.</p> <p>Replace the suspected antenna-network servo-amplifier sub-assembly with one that is known to be operative. If this is not possible, check and/or replace V901, V902, and G901.</p> <p>Replace suspected antenna tuning capacitor subunit with one that is known to be operative.</p> <p>Check to determine whether P1001 is properly inserted.</p> <p>Check continuity of 24-volt line through relays K609, K613, K616, and K617; check operation of relays.</p> <p>Replace brushes if defective.</p> <p>Replace motor.</p> <p>Check S1101A front and rear to determine whether or not they are synchronized properly with respect to the number of turns remaining on the ceramic foil form. Check the grounding circuit through</p>



Symptom	Probable cause	Correction
<p>13. Continued result in breaking the ribbon when the ceramic coil form reaches inductance stop.</p>		<p>S1101A front and rear and S606.</p>
<p>14. The dc motor (B1102) operates the variable inductor, but the motor fails to stop before the ceramic coil is within a few turns of being completely wound. This may result in breaking the ribbon when the ceramic coil form reaches its maximum inductance stop.</p>	<p>Terminal 1 of K617 is not removed from ground by S1101A rear as it should be, just before the ceramic coil form reaches its maximum inductance stop.</p>	<p>Check S1101A rear to determine whether or not it is synchronized properly with respect to the maximum inductance stop of the ceramic coil form.</p>
<p>15. No indication on the test meter on any transmitter band with the TEST METER switch in the PA GRID position.</p>	<p>Filaments of V201 in the power amplifier not on because of failure of the tube filaments themselves, or faulty operation of the power-amplifier blower interlock, S202.</p>	<p>Check the filaments of V201 and replace tube, if necessary. Check to determine whether voltage is present across the pa blower, B202. If the pa blower operates intermittently, the motor brushes should be checked and replaced, if necessary.</p>
	<p>No rf voltage from the master oscillator present at exciter receptacle J101. The magnitude of this voltage should be approximately 5 volts, rms, with the master-oscillator output connected to J101 of the exciter.</p>	<p>Determine whether proper supply voltages are present at the oscillator power plug, P802. Terminal A, +150 v; terminal C, +13 v; terminal D, ground; terminal E, 24 v. If these voltages are not substantially as shown above, check, and if necessary, replace voltage regulator V601, or resistor R601. If supply voltages are as they should be, measure the voltage at pin 1 of V801. No negative voltage at this point indicates that the oscillator is not functioning. If the oscillator is functioning and no output is obtained from the master oscillator, resistance and voltage measurements should be made throughout the master oscillator subchassis to locate a possible component failure. If it becomes necessary to remove the oscillator from its mounting, refer to paragraph 3-1c. At no time should the round shield can which encloses the oscillator-frequency controlling parts be removed or loosened. Should it appear that trouble exists within the sealed portion of the oscillator, the entire master oscillator should be removed from the transmitter and replaced.</p>
	<p>Exciter completely out of alignment</p>	<p>Refer to paragraph 3-10.</p>
	<p>Exciter band switch shaft disengaged from BAND SELECTOR, or exciter band switch coupling clamp not tightened properly.</p>	<p>Refer to paragraph 3-8.</p>
	<p>Exciter camshaft disengaged from the TUNING CONTROL, or cam shaft coupling clamp not tightened properly.</p>	<p>Adjust as required, then refer to paragraph 3-8.</p>

Symptom	Probable cause	Correction
	V101 and/or V104 tubes or associated circuits defective.	Check and replace tubes if defective. Check voltage present between pin 8 of V104 and ground. An incorrect voltage indicates trouble at or before this point in the circuit. The presence of an rf signal at the control grid of V104 develops a negative dc voltage, the value of which is normally between -12 and -30 volts, depending on which exciter band is in use. When the BAND SELECTOR is set to the 1.5- to 6.0-mc range and the negative voltage at pin 8 of V104 is not present, the trouble is probably in the V101 stage (assuming that the master oscillator is delivering voltage to J101 of the exciter), since V102 and V103 are not used in this frequency range.
	No connection between P102 of exciter and P203 of power amplifier.	Check spring contactor E605, and clean, if necessary.
	Control grid of V201 in power amplifier (center pin of V201 socket) grounded.	Check and repair.
	Pa grid metering circuit defective (M602).	Check the following and repair or replace, if necessary; Open circuit at pin 10 of P201. TEST METER switch (S607) contacts damaged or dirty.
	Pin 5 of exciter power plug P101 not grounded by keying relay K605.	Connect pin 5 of P101 to ground to determine whether this causes the test meter to indicate pa grid current. If this proves to be the case, determine whether keying relay K605 is energized by the SERVICE SELECTOR switch in the CALIBRATE position. If the relay is not energized, check R621 and replace, if necessary.
16. Below normal pa grid indication on the meter on all or some transmitter bands.	K201 defective -----	Check the energizing circuit of K201. This circuit consists essentially of K201 and S101D (rear).
	Exciter not properly alined -----	Refer to paragraph 3-10.
	Subnormal tubes in the exciter -----	Check V101, V102, V103, and V104. Replace, if necessary.
17. High-voltage dynamotor. D602 does not start.	F603 defective -----	Replace F603. If replacement fuse burns out, check for a short in the 24-volt and +1,000-volt circuits of D602 or high-voltage power supply A1200 or PS602.
	K603 not energized -----	Check voltage between term. 3 of K616 and ground. Zero volts should be obtained. If 24 volts is obtained, K616 is energized or defective. If energized refer to step 11.
	K603 defective -----	Check contacts of K603. Clean if necessary. Check operation of relay; replace if defective.
	K609 defective -----	Check operation of K609.
18. High-voltage power supply. No output.	No input voltage at E603 -----	Check fuse F603. Check +24-volt source.

Symptom	Probable cause	Correction
18. Continued	No starting and/or operating bias -----	Check C1203 for possible short. Check diode CR1214 and resistors R1208, R1213, and R1214.
	Oscillator inoperative -----	Check R1208 and K1200. Check for short in +1,000-volt output circuit. Check T1200 secondary windings, terminals 4 and 5 and terminals 5 and 6 for opens.
	Oscillator malfunctioning -----	Check transistors Q1200 through Q1207 by substitution. Check resistors R1200 through R1203 and R1209 through R1212. Check L1200.
	Defective rectifier circuit -----	Check diodes CR1200 through CR1212, resistors R1204, R1205, and capacitors C1201 and C1202.
19 Zero indication is not obtained on the test meter when the TEST METER switch is set to the PA CATH position.	Defective clamper tube circuit in the power amplifier.	Check V202 and associated detail parts and potentials to determine source of trouble.
	No fixed bias on the power amplifier. Fixed bias at pin 10 of P201 should be approximately -22 volts when the SERVICE SELECTOR switch is set to the CW position with the key open.	Check circuits from the -45-volt output to D601 or PS601 to pin 10 of P201. Check C201 and replace if defective.
	K605 closed -----	Check K605 circuit.
20. Pa cathode current not in shaded area when key or microphone switch is closed.	Antenna disconnected -----	Check and repair antenna connections.
	V202 not biased to cutoff during keying	Check C208, K202, K615, and K605.
	Tuning system defective -----	Check components in tuning, phasing and loading discriminator circuits. Refer to steps 20, 21, and 22.
	Pa grid drive low -----	Check exciter and oscillator stages.
	Pa stage defective -----	Check tube and components in pa stage.
	Pa band switch not positioned properly	Check and synchronize band switch shaft with BAND SELECTOR.
	No connection between P204 and P301 and P304.	Check connection.
21. Improper operation of the power amplifier servo system.	No torque from B201 due to lack of dc error voltage from the power-amplifier discriminator.	Check at the junction of R222 and R223 to determine whether a short circuit to ground is present at this point. Check C245 and replace, if defective. Check operation of K201. This relay should be energized when the BAND SELECTOR is in the 1.5- to 6.0-mc range.
	No torque from B201 due to failure of the power-amplifier servo amplifier.	Check and replace G201, V204, or V203. Check B201.
	Torque from B201 present in only one direction.	Either CR201 or CR202 is defective. Check and replace, if necessary.
22. The antenna tuning capacitor does not begin its tuning operation.	No dc error voltage present at pin B of P302.	Check connections in the discriminator to pin B of P302 to determine whether an open circuit or short circuit exists.

Symptom	Probable cause	Correction
22. Continued	No dc error voltage present at pin 1 of P901.	Check circuits between pin B of J609 through S614B front and contacts 8 and 9 of K616, to pin 1 of P901.
	No torque from B1001 -----	Check V901, V902, G901, and associated components. Check B1001.
	Torque from B1001 present in one direction only.	Check CR301 and CR203.
23. The variable inductor does not begin its tuning operation.	No dc present at pin F of P302 -----	Check loading discriminator to pin F of P302.
	No dc present at pin 12 of J611 -----	Check connections between pin F of J609 through S614B rear to pin 12 of P901.
	No torque from B1101 -----	Check V903, V904, and associated components. Check B1101 and replace, if defective.
	Pin 2 of P901 not grounded when S1002 is at minimum capacitance position.	Check S1002 and S1003.
24. TUNING INDICATOR does not light when the variable inductor and antenna tuning capacitor have apparently completed the tuning operation.	DIAL DIM switch is in OFF position ----- Defective dial lamp in the TUNING INDICATION.	Turn the DIAL DIM switch to DIM or FULL. Replace lamp if defective.
	Slight residual error in tuning system -----	If sidetone is present in CW position, no correction is necessary. If no sidetone is present, check servo system.
25. TUNING INDICATOR is lighted even though the transmitter has not completed its tuning cycle.	K901 not energized -----	Check CR901, CR902, and associated components.
26. No 400-cycle sidetone heard when transmitter is keyed in CW position.	Sidetone amplifier defective -----	Check V403 and associated components.
27. No indication on VU meter while attempting to operate in VOICE or VOICE/FSK positions.	Defective C420 ----- Defective meter (M603) ----- Defective coupling from modulator to meter M603. Defective components in modulator subchassis.	Check and replace, if necessary. Check and replace, if necessary. Check resistors R439, R440, R441, R607, and capacitor C601. Check modulator subchassis.
28. Dial lights in the BAND SELECTOR and TUNING CONTROL indication windows not lighting in the DIM position of the DIAL DIM switch.	One or more dial lights burned out -----	Turn DIAL DIM switch to FULL and determine which dial light is burned out. Access to lamp is gained by removing window gasket cover.

## 2-9. Voltage and Resistance Checks

Voltage and resistance diagrams for the various subchassis and main frame of the transmitter are shown in figures 2-57 through 2-65. These illustrations show the values that should be obtained

at the tube-socket pins and terminal boards. If a measured value varies more than 10 percent from the given value, closer examination of the involved circuits is necessary.

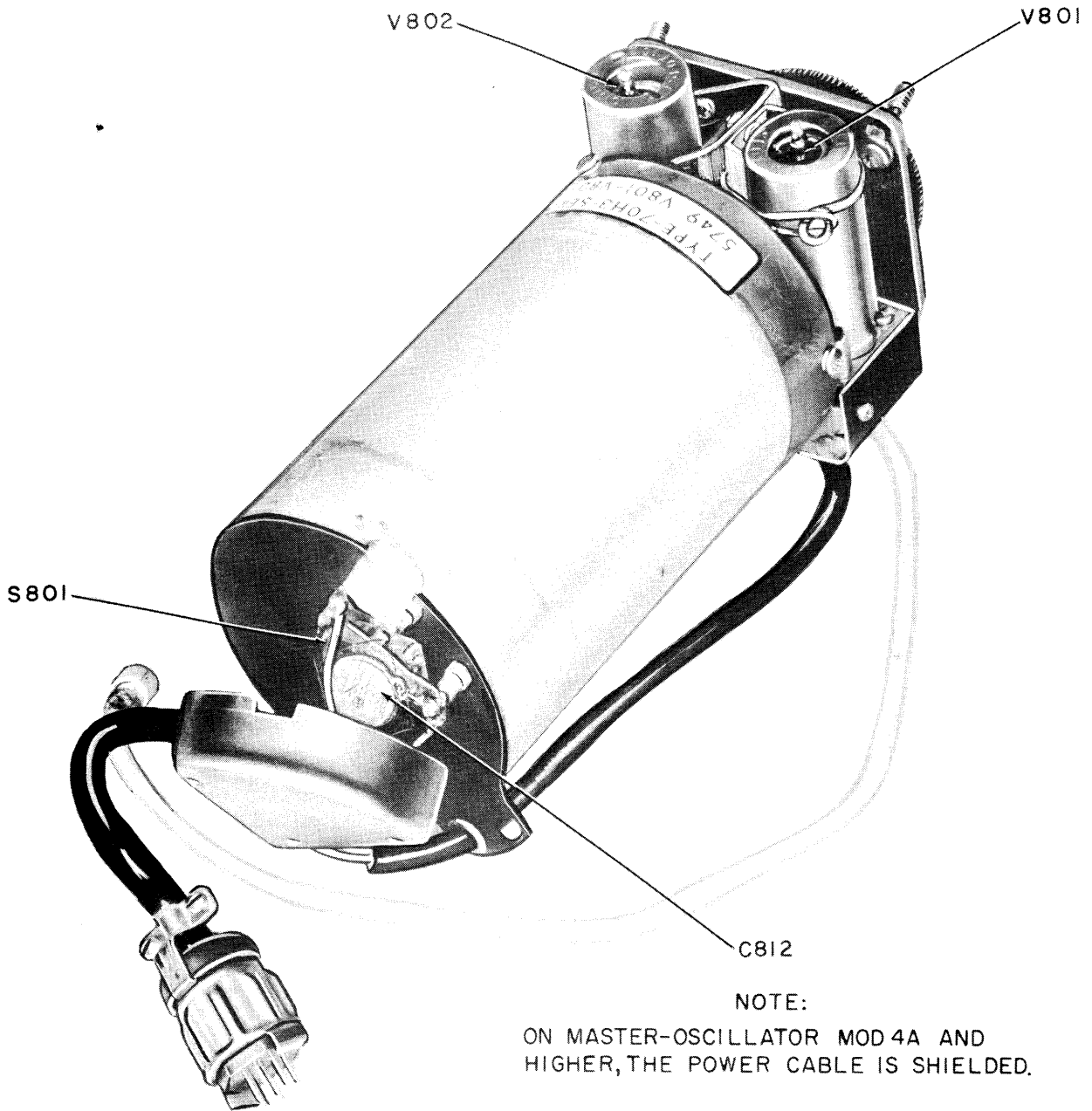

TM 5820-335-35-19

Figure 2-3. Master-oscillator subchassis, top view.

NOTE:  
ON MASTER-OSCILLATOR MOD 4A AND  
HIGHER, THE POWER CABLE IS SHIELDED

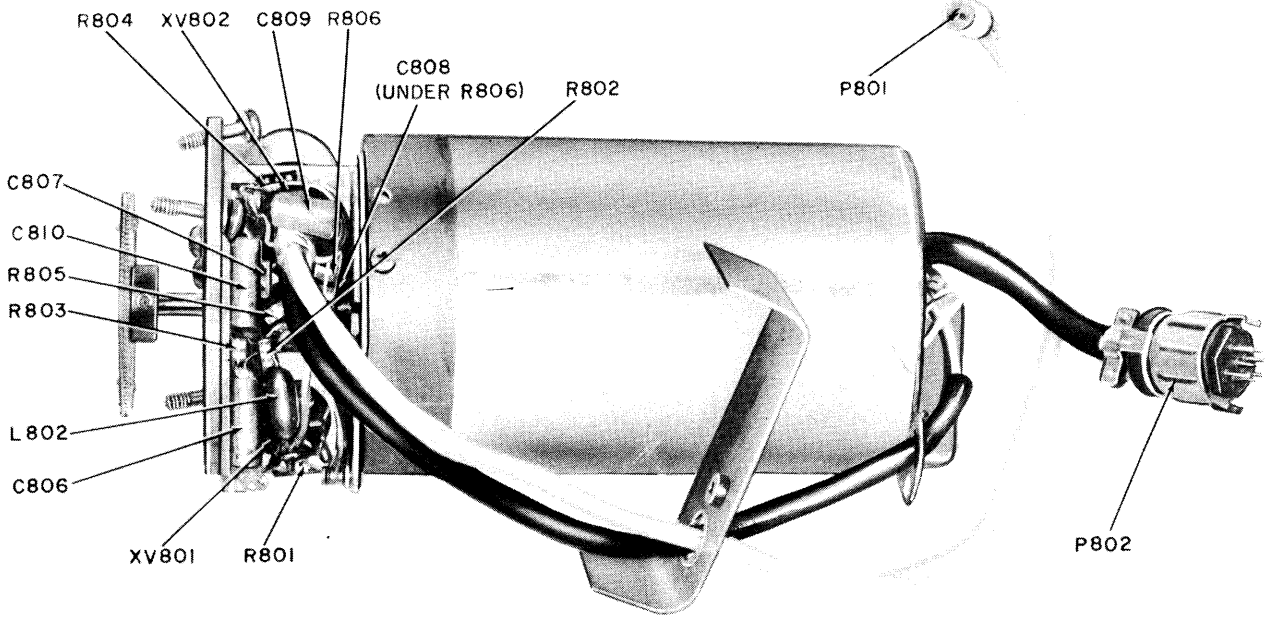

TM5820-335-35-20

Figure 2-4. Master-oscillator subchassis, bottom view.

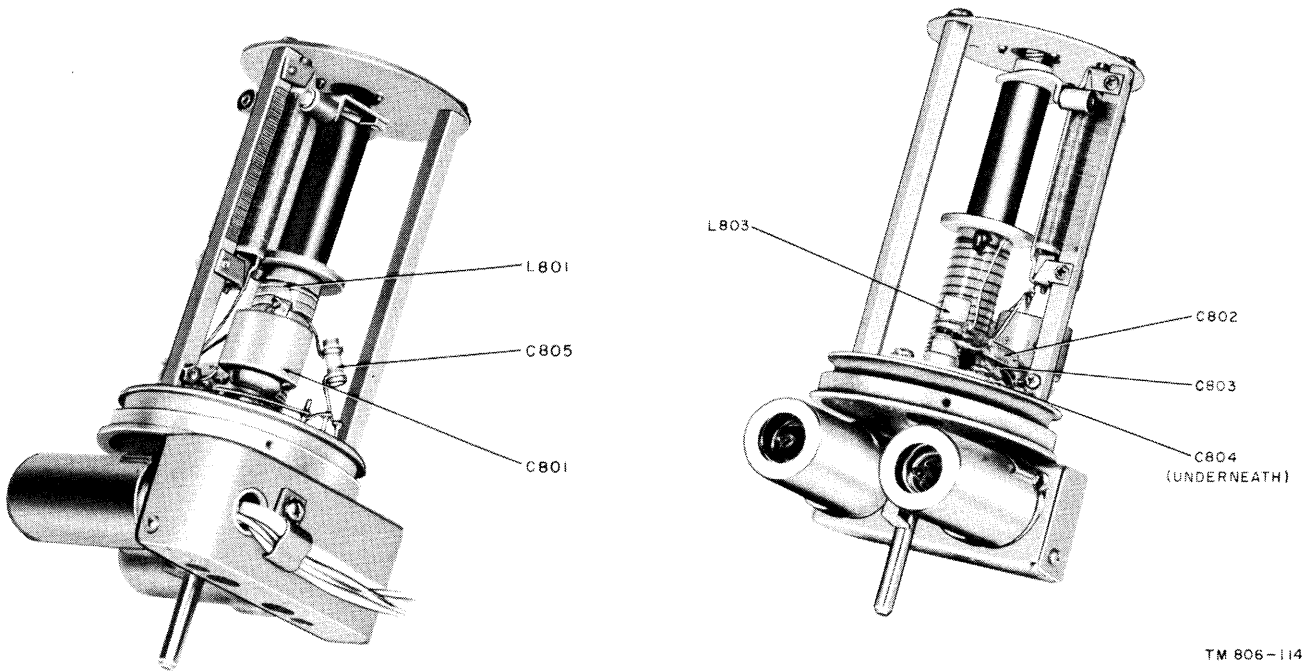

TM 806-113

TM 806-114

Figure 2-5. Master-oscillator subchassis, bottom view, sealed circuit, cover removed.

Figure 2-6. Master-oscillator subchassis, top view, sealed circuit, cover removed.

NOTE:

IN THE T-195A/GRC-19, TWO METAL ANGLE BRACKETS ARE FASTENED ON THE TOP OF THE END PLATES OVER THE CAM FOLLOWER GROOVES TO LIMIT VERTICAL DISPLACEMENT OF THE SLUG RACK.

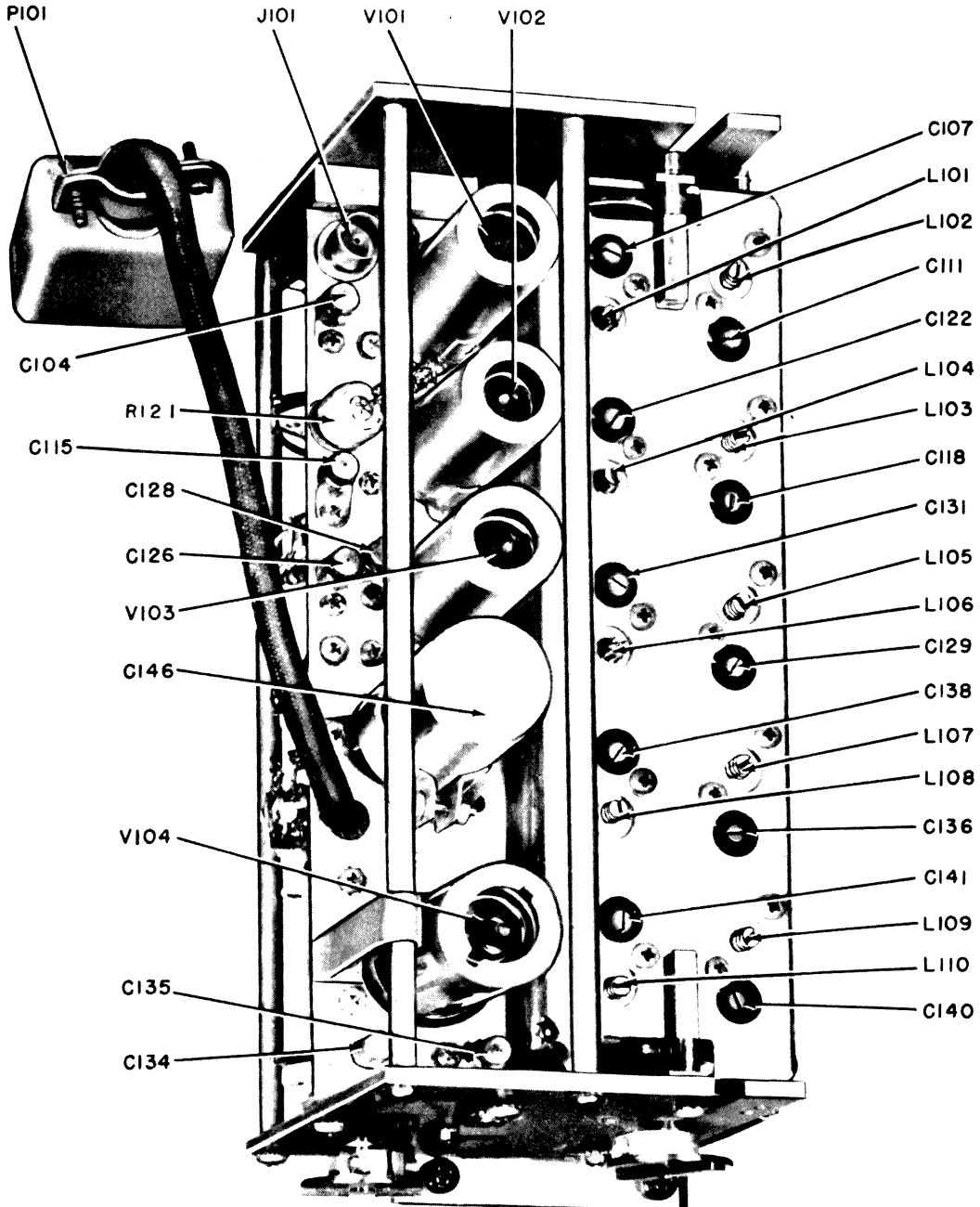

TM 5820-335-35-21.

Figure 2-7. Exciter subchassis, top view.

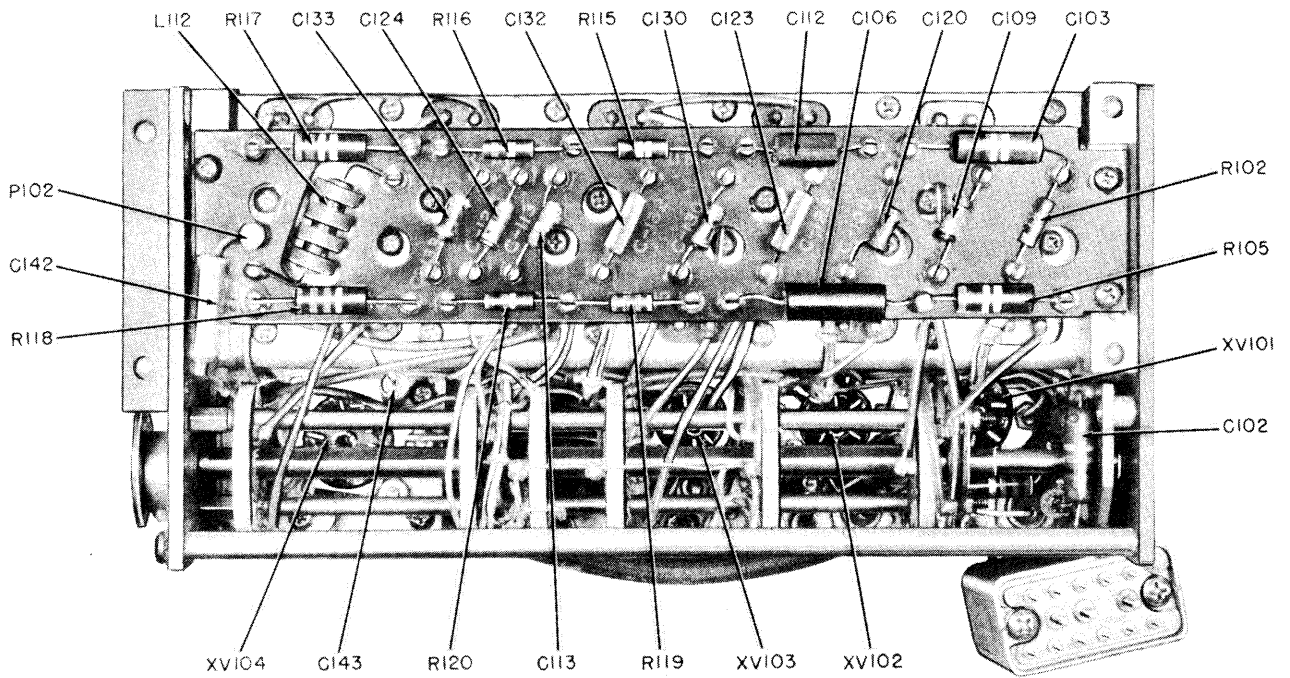

TM 806-79

Figure 2-8. Exciter subchassis, bottom view.



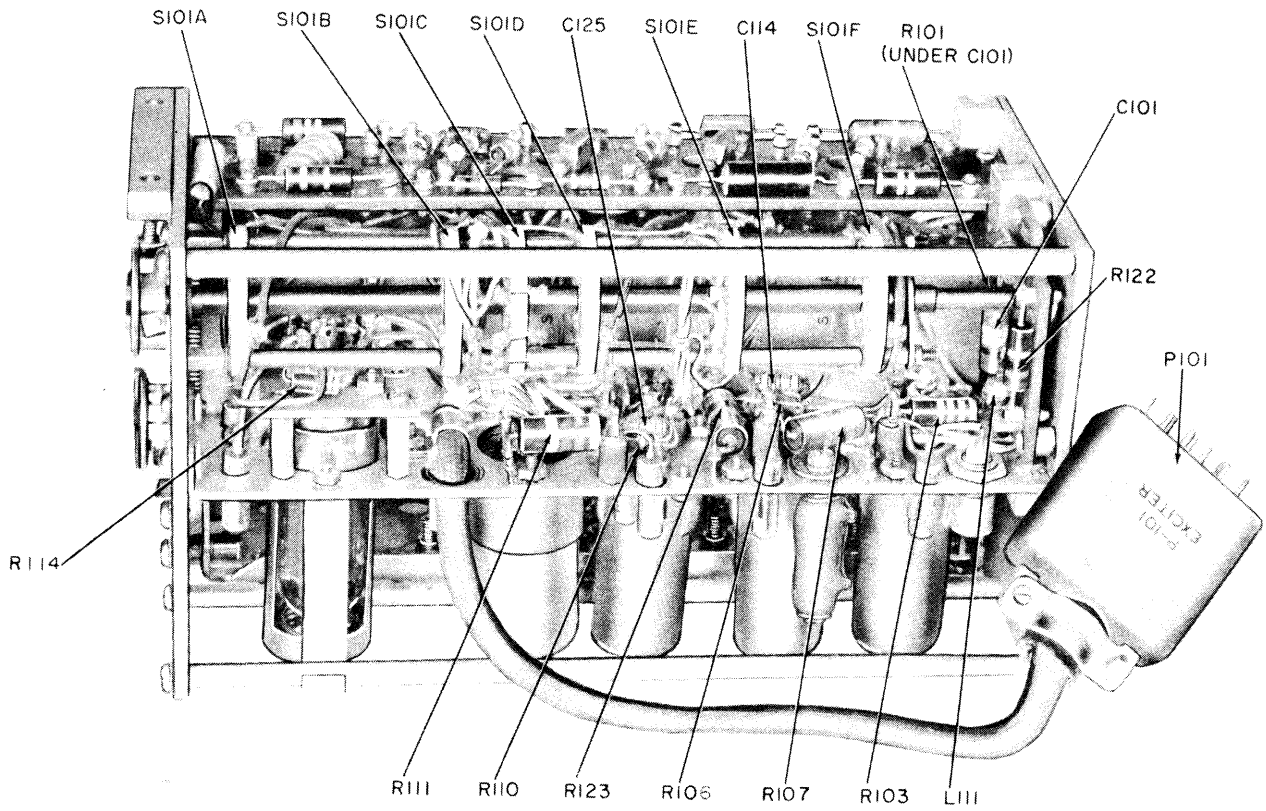

TM 806-80

Figure 2-9. Exciter subchassis, side view.

NOTE:

IN THE T-195A/GRC-19, TWO METAL ANGLE BRACKETS ARE FASTENED ON THE TOP OF THE END PLATES OVER THE CAM FOLLOWER GROOVES TO LIMIT VERTICAL DISPLACEMENT OF THE SLUG RACK.

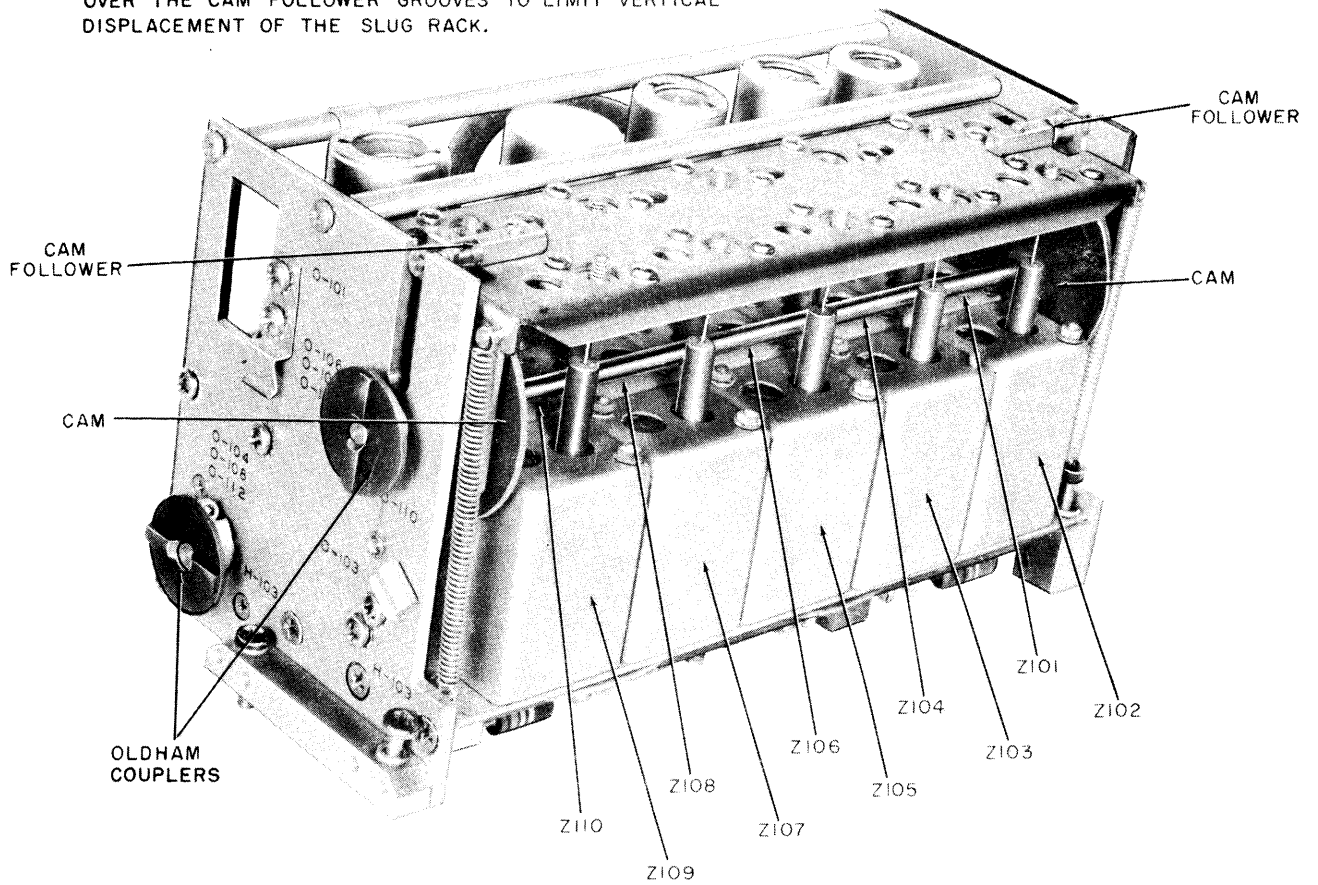

TM 5820-335-35-22

Figure 2-10. Exciter subchassis, front view.

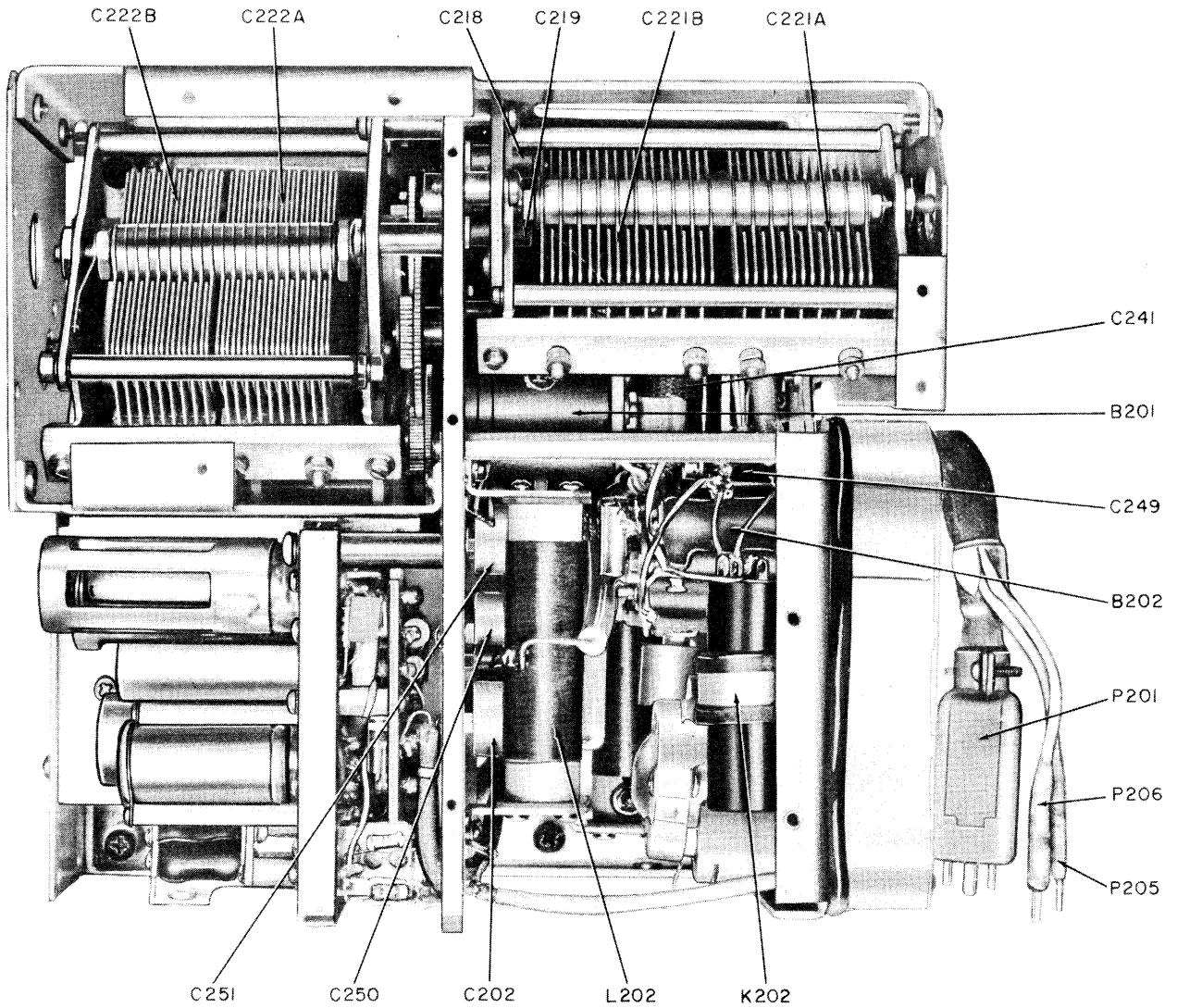

TM 806-83

Figure 2-11. Power-amplifier subchassis, top view.

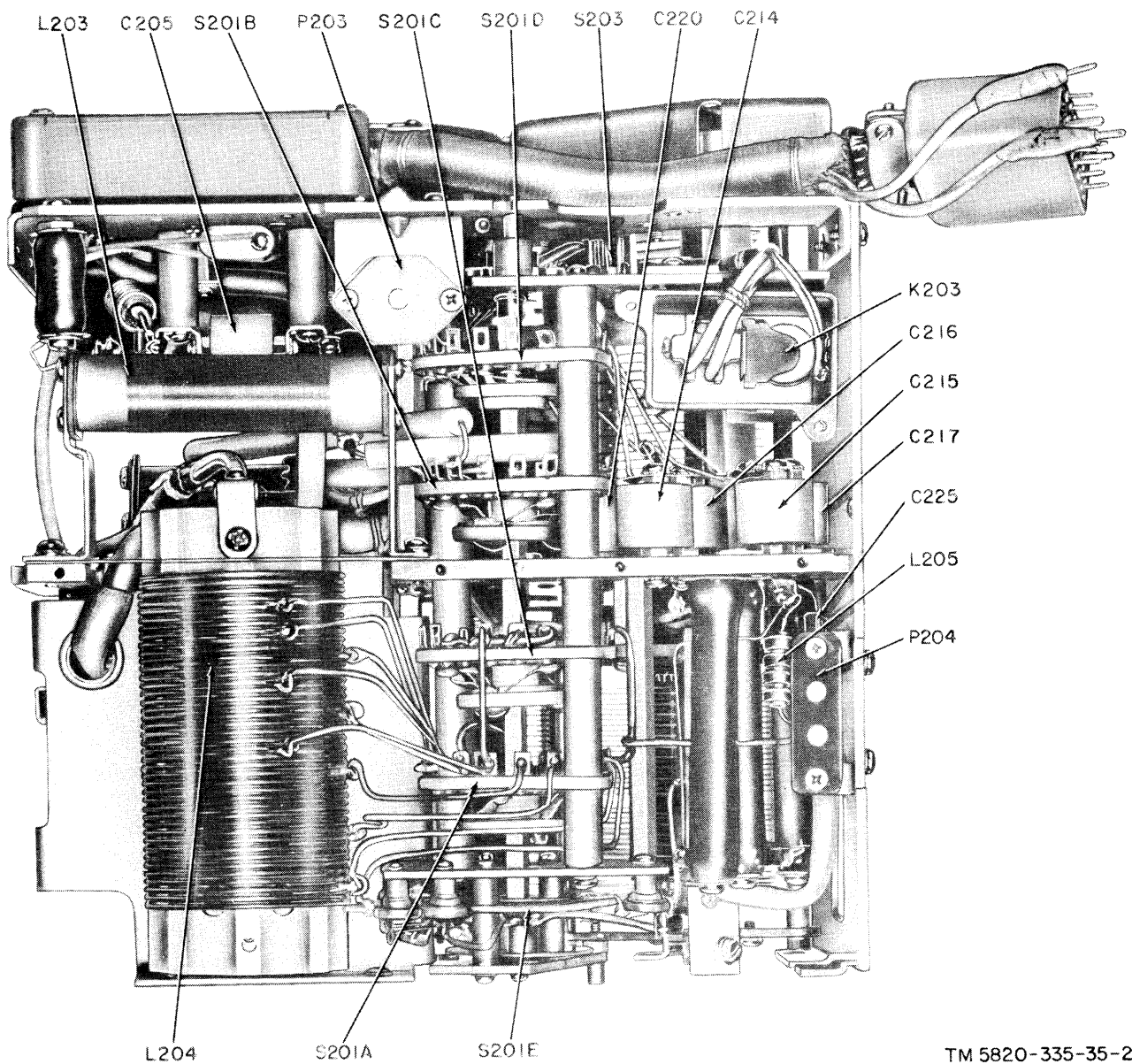

TM 5820-335-35-23

Figure 2-12. Power-amplifier subchassis, bottom view.

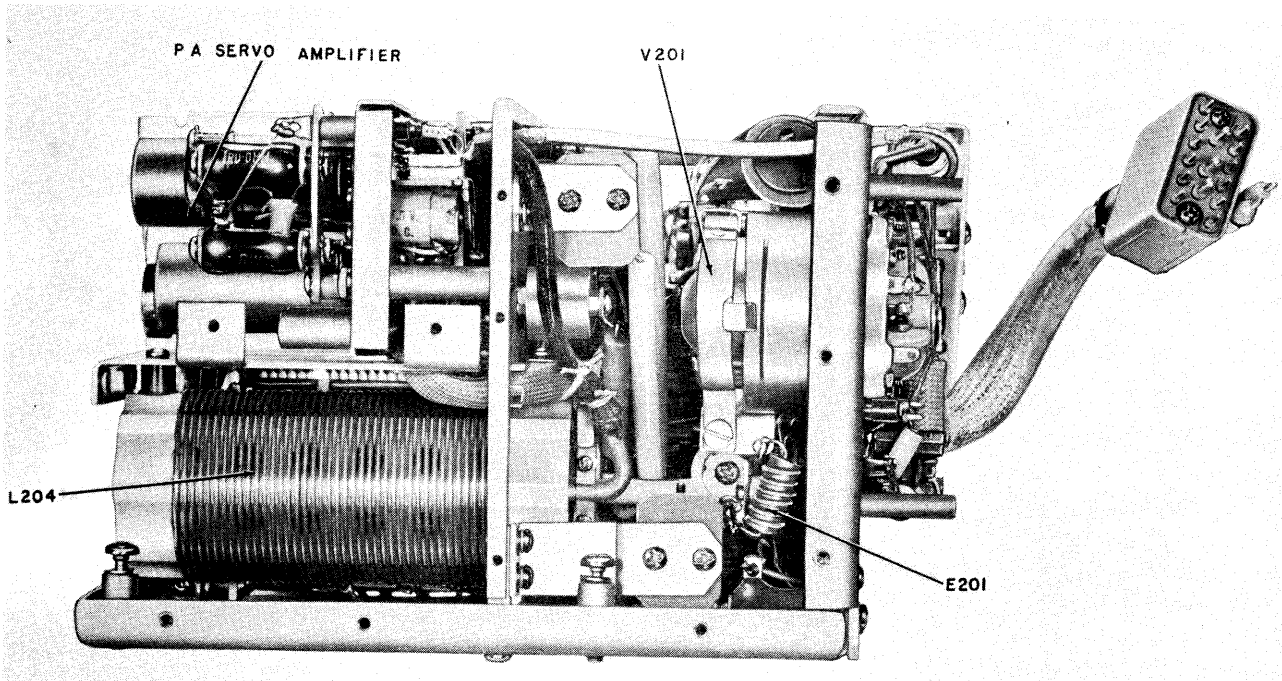

TM 806-85

Figure 2-13. Power-amplifier subchassis, side view.

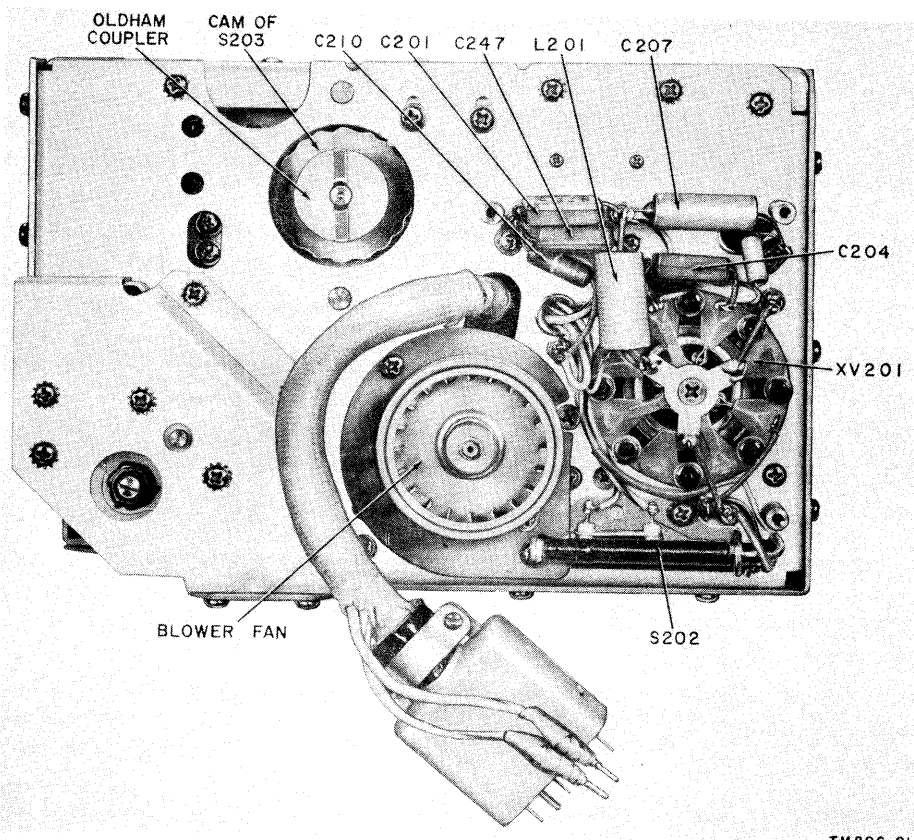

TM 806-81

Figure 2-14. Power-amplifier subchassis, front view.

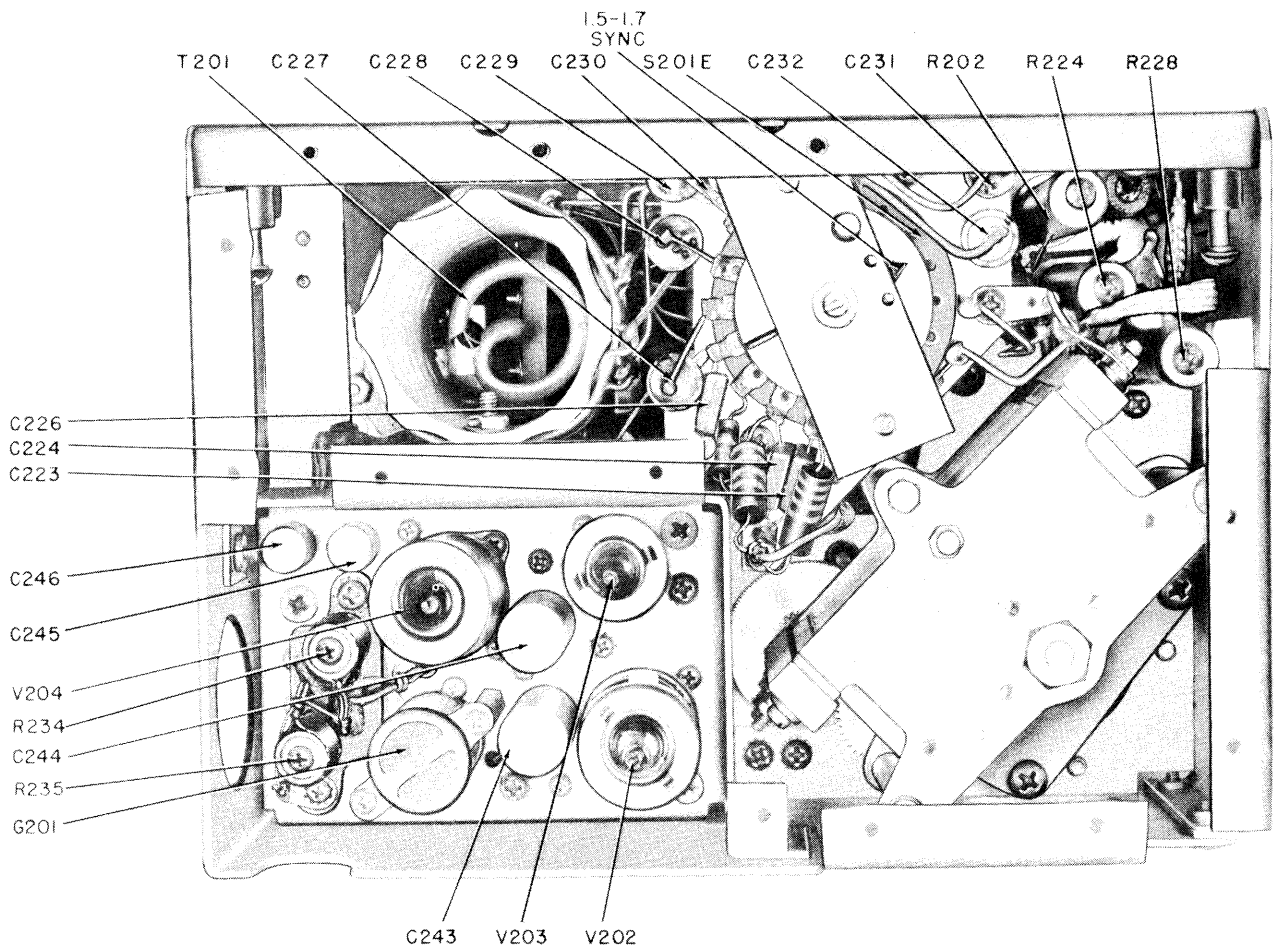

TM 806-82

Figure 2-15. Power-amplifier subchassis, rear view.

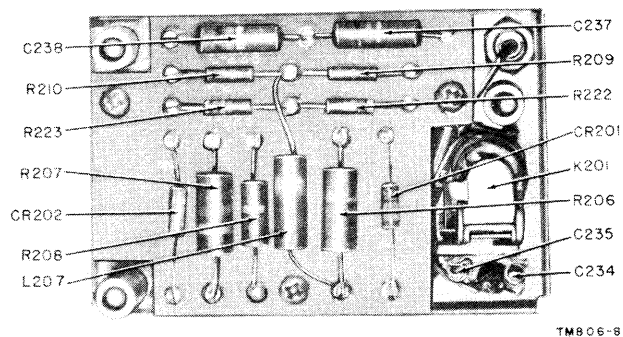
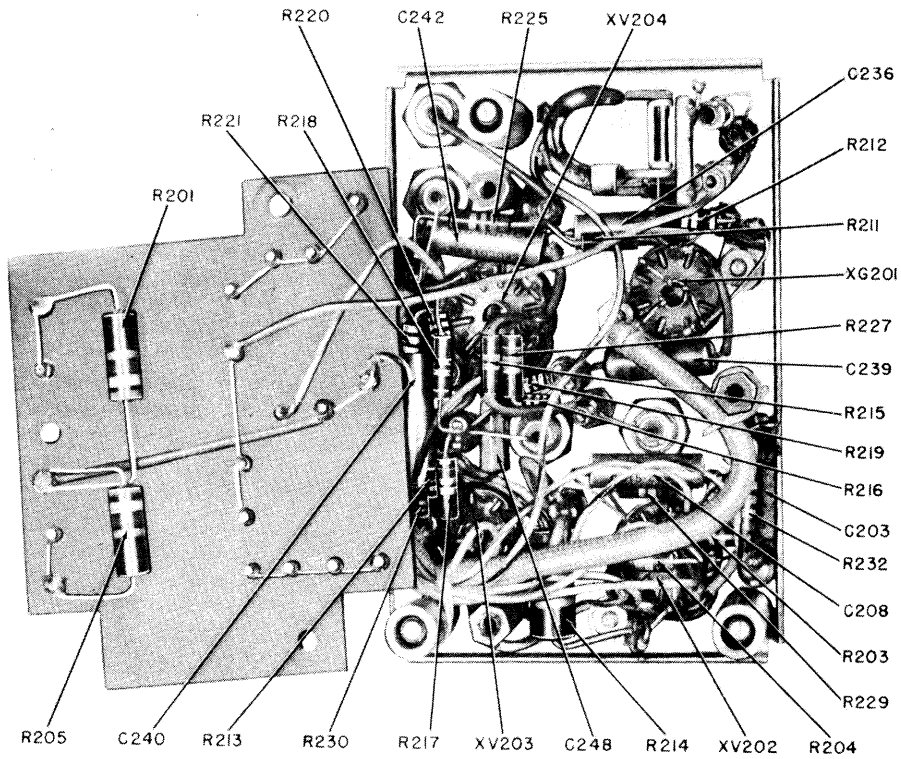

Figure 2-16. Power-amplifier discriminator, bottom view.





TM 806-86

Figure 2-17. Power-amplifier discriminator, terminal board.

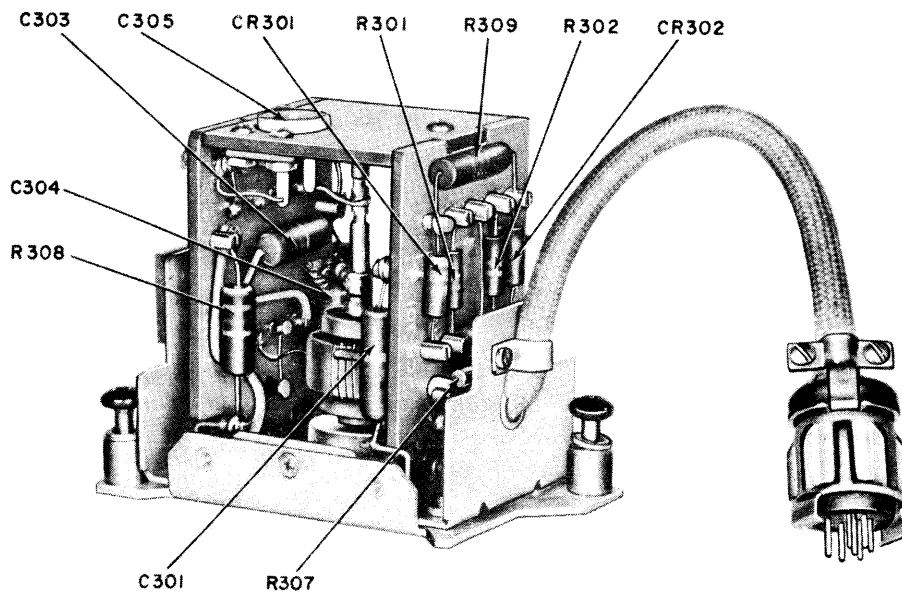

TM 806-64

Figure 2-18. Discriminator subchassis, right view.

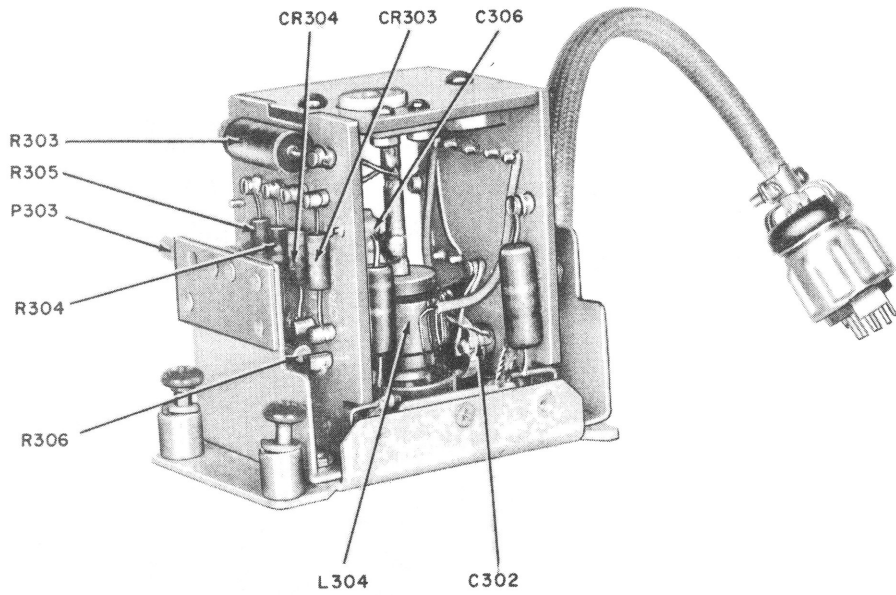

TM 806-65

Figure 2-19. Discriminator subchassis, left view.

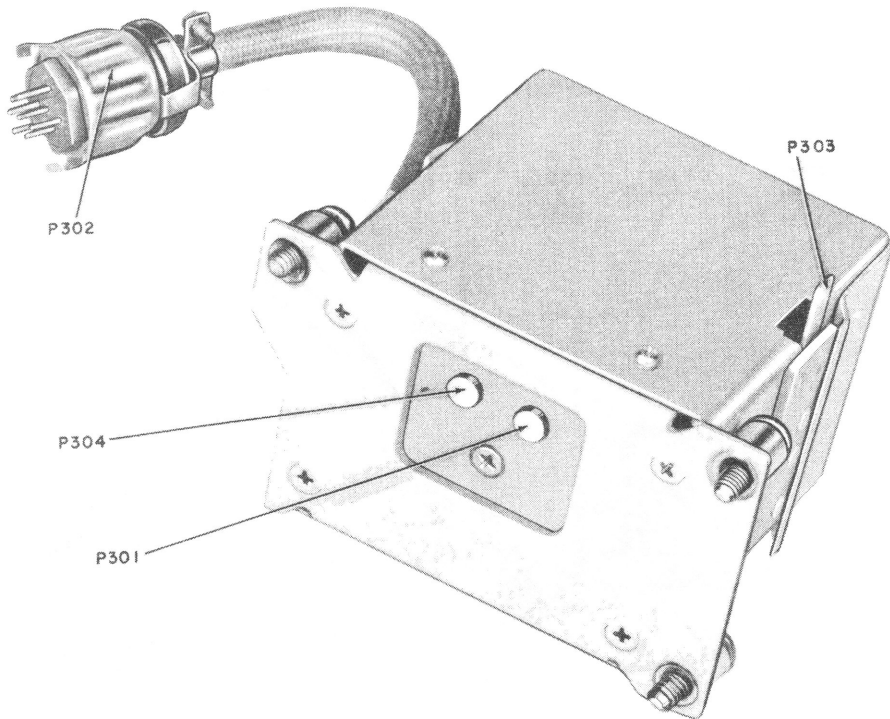

TM 806-66

Figure 2-20. Discriminator subchassis, bottom view.



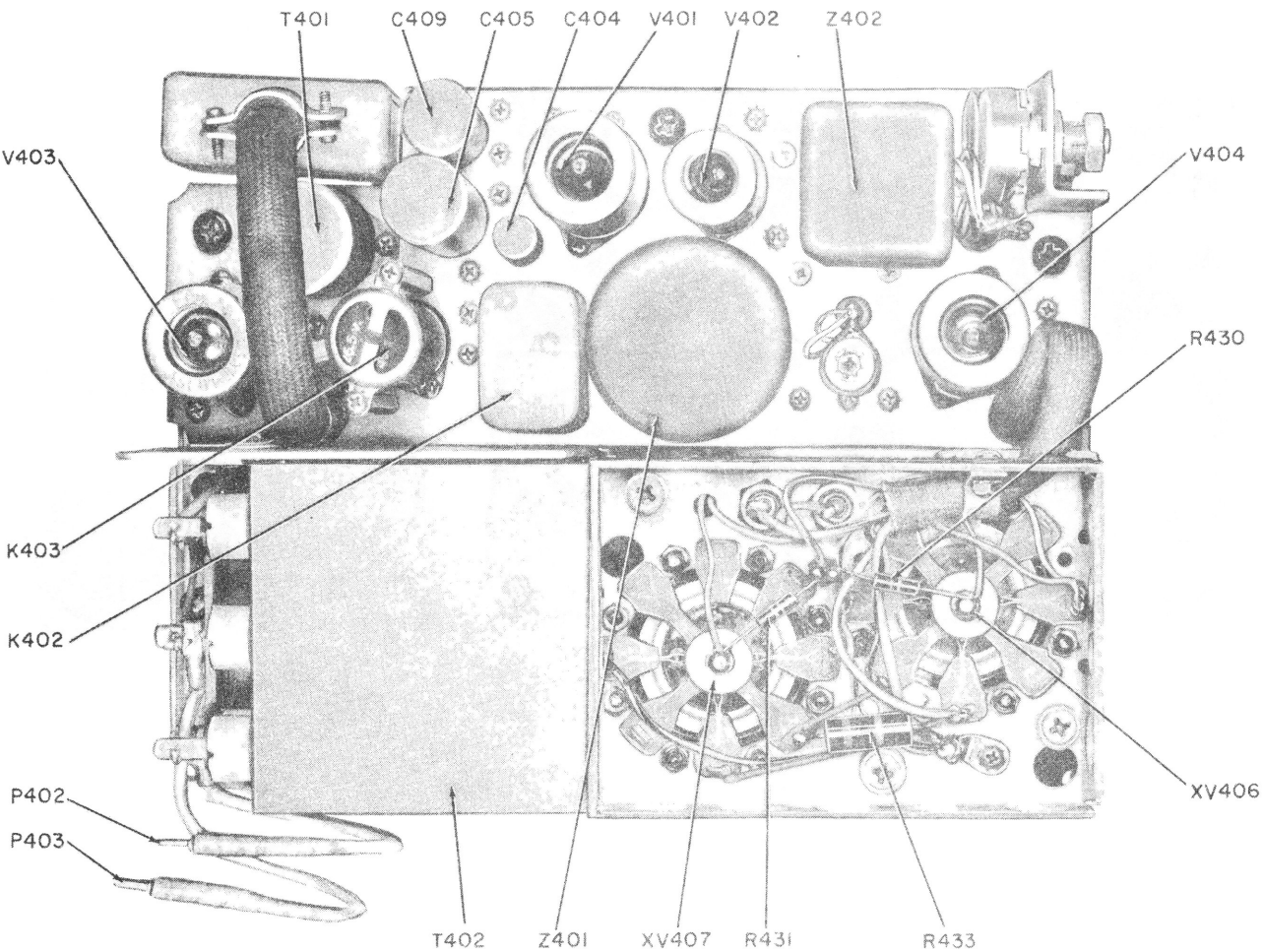

TM 806-68

Figure 2-21. Modulator subchassis, top view.

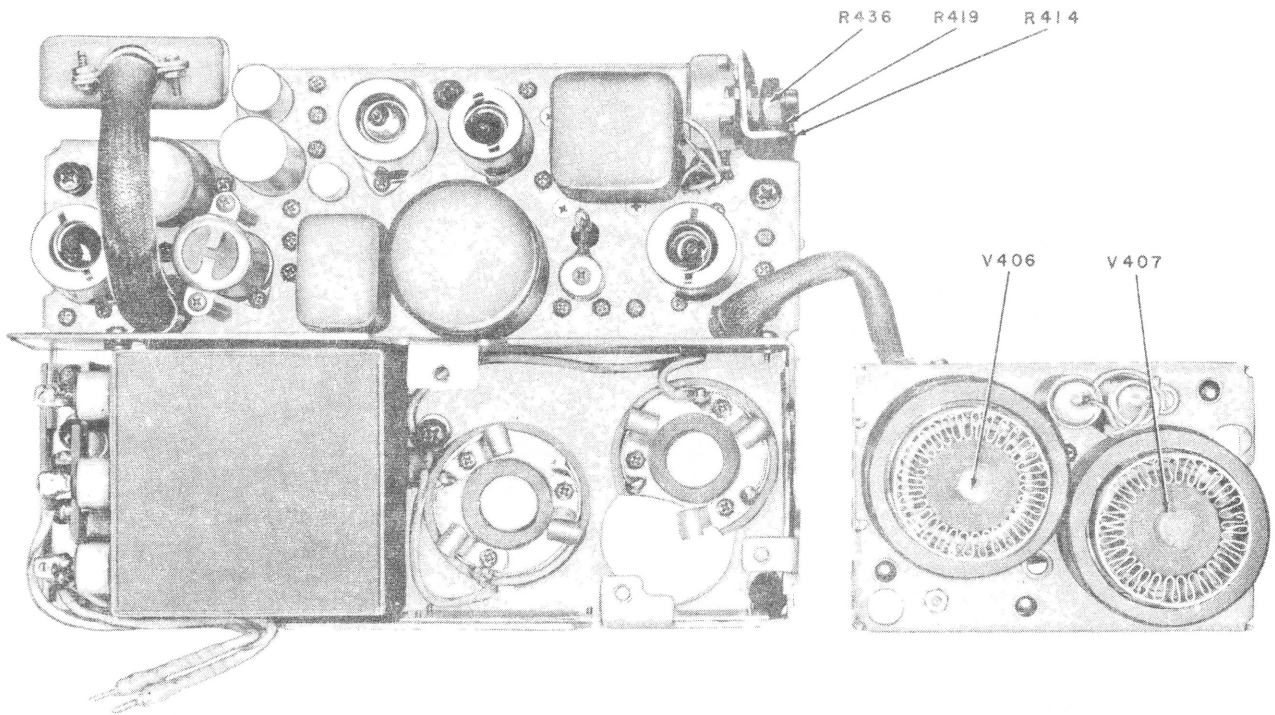

TM 806-69

Figure 2-22. Modulator subchassis with modulator-tube subassembly removed.

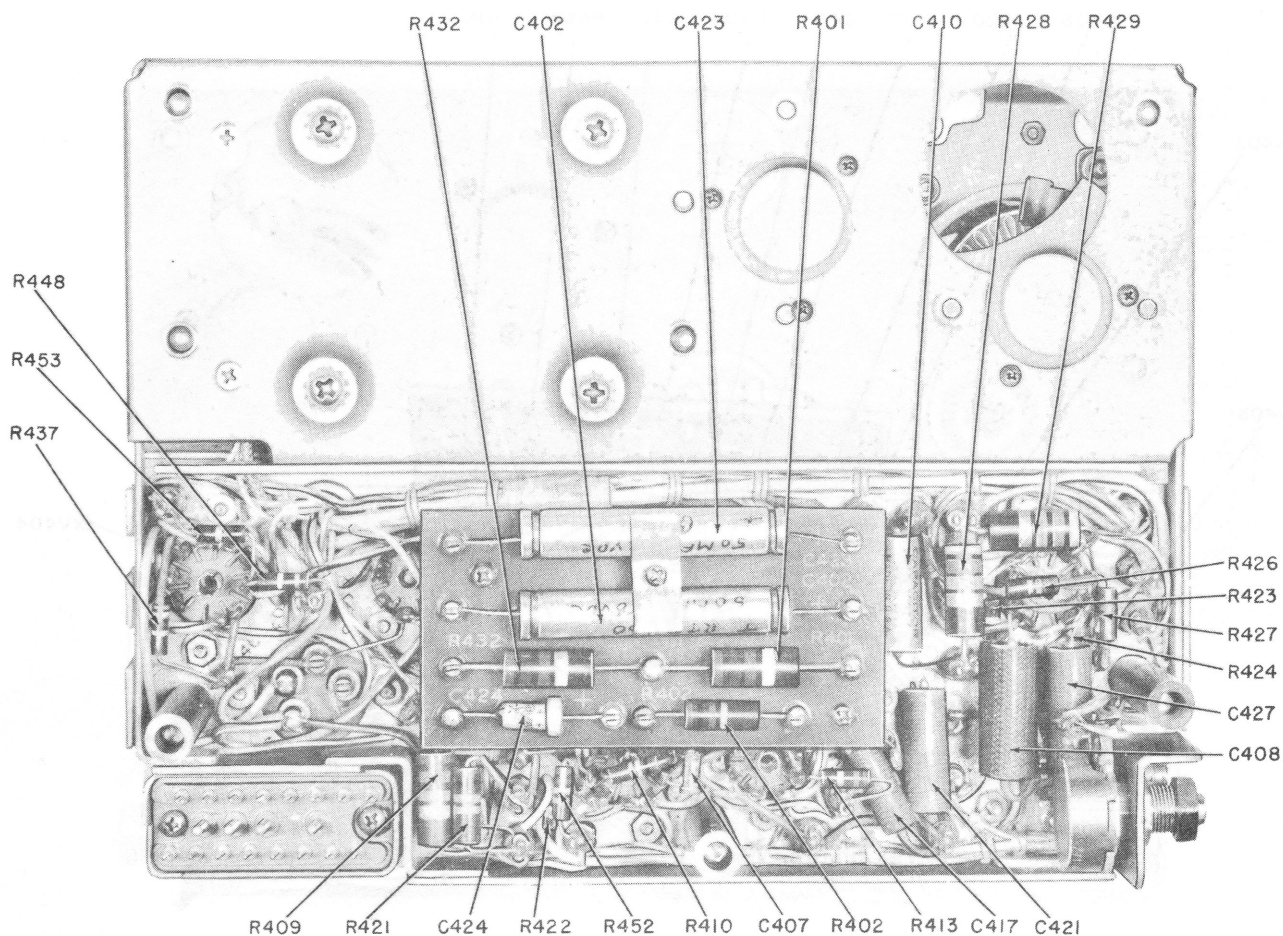

TM 806-70

Figure 2-23. Modulator subchassis, bottom view.

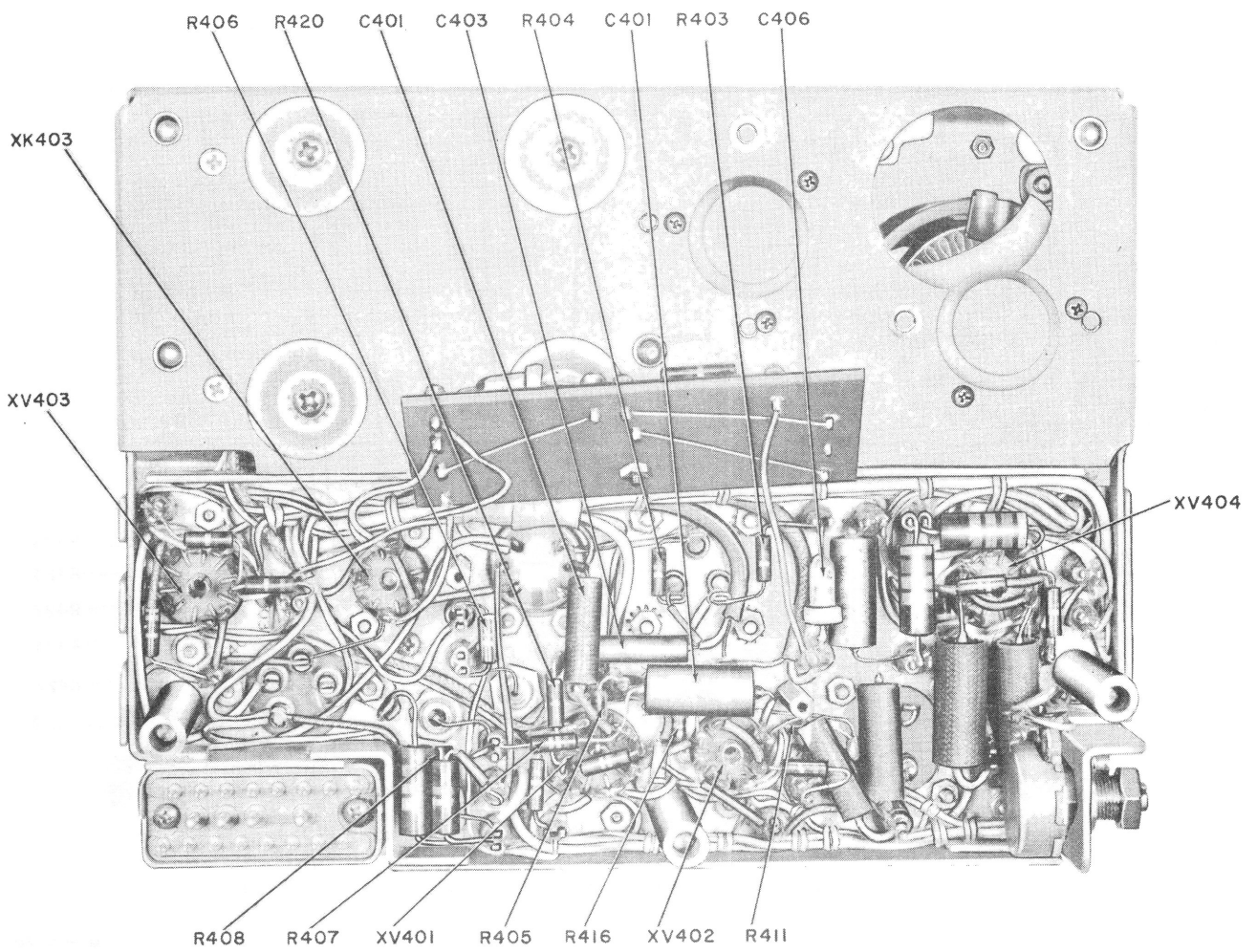

TM 806-71

Figure 2-24. Modulator subchassis, terminal board removed.

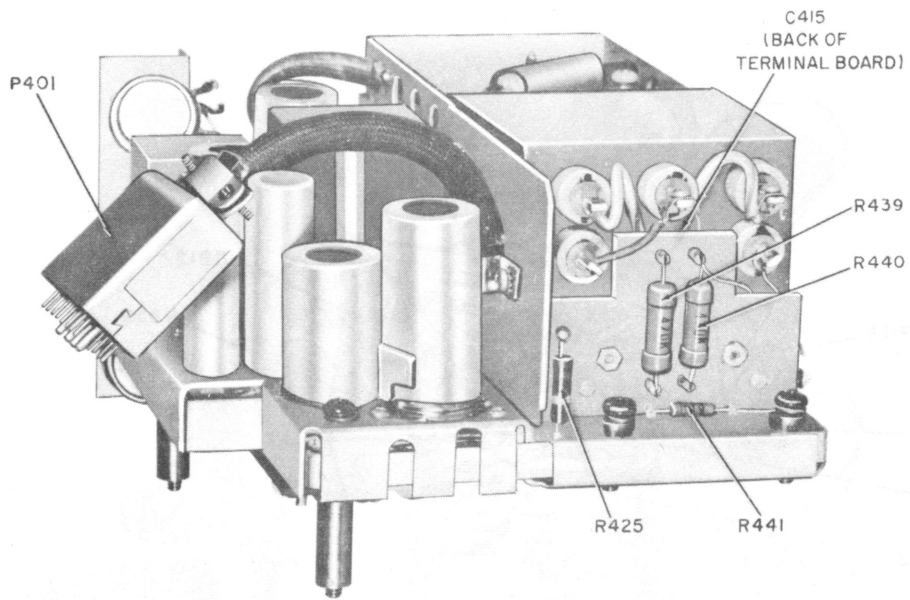

TM 806-67

Figure 2-25. Modulator subchassis, rear view.

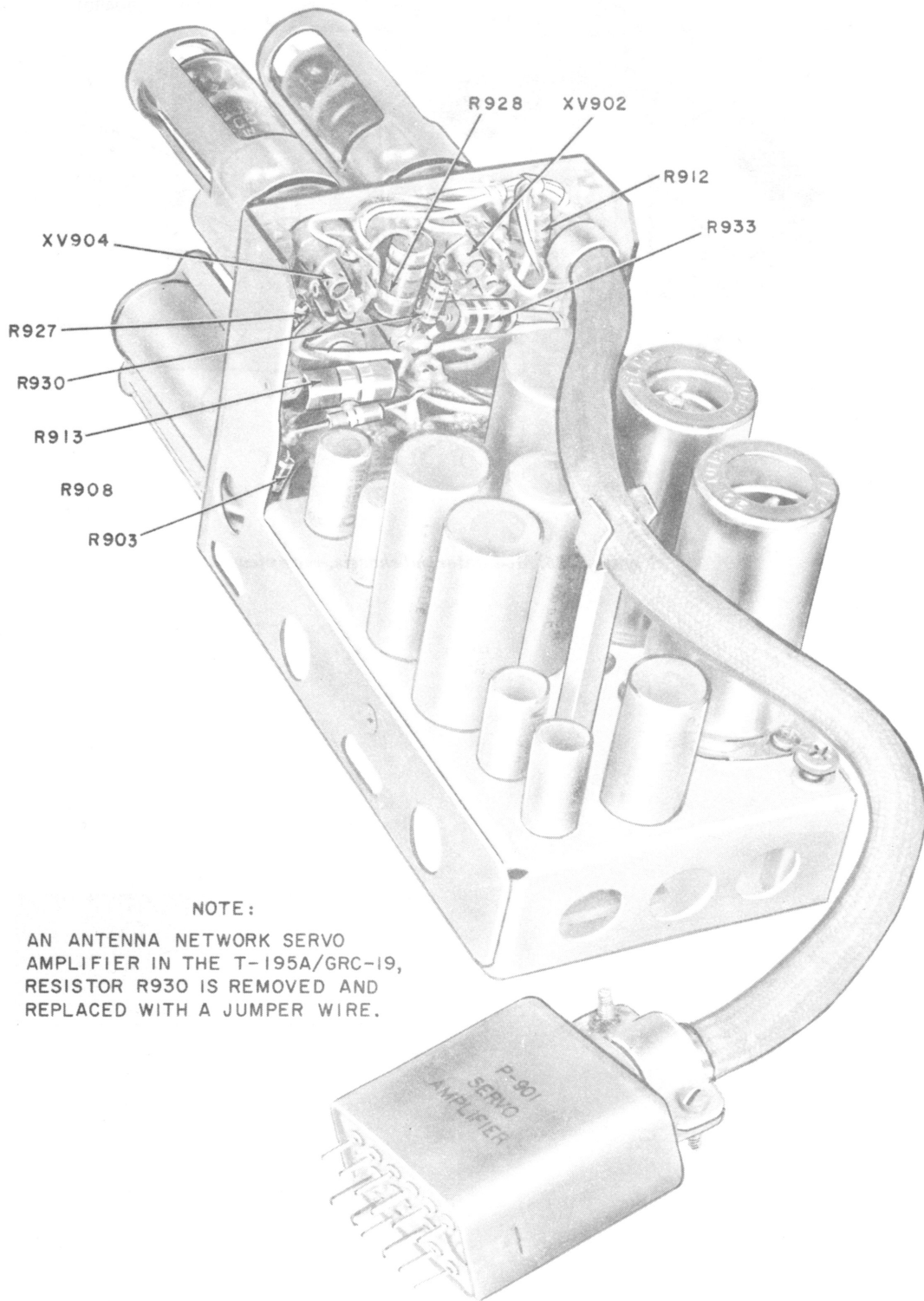

NOTE:

AN ANTENNA NETWORK SERVO AMPLIFIER IN THE T-195A/GRC-19, RESISTOR R930 IS REMOVED AND REPLACED WITH A JUMPER WIRE.

TM 5820-335-35-24

Figure 2-26. Antenna network servo amplifier, cover removed, top view.

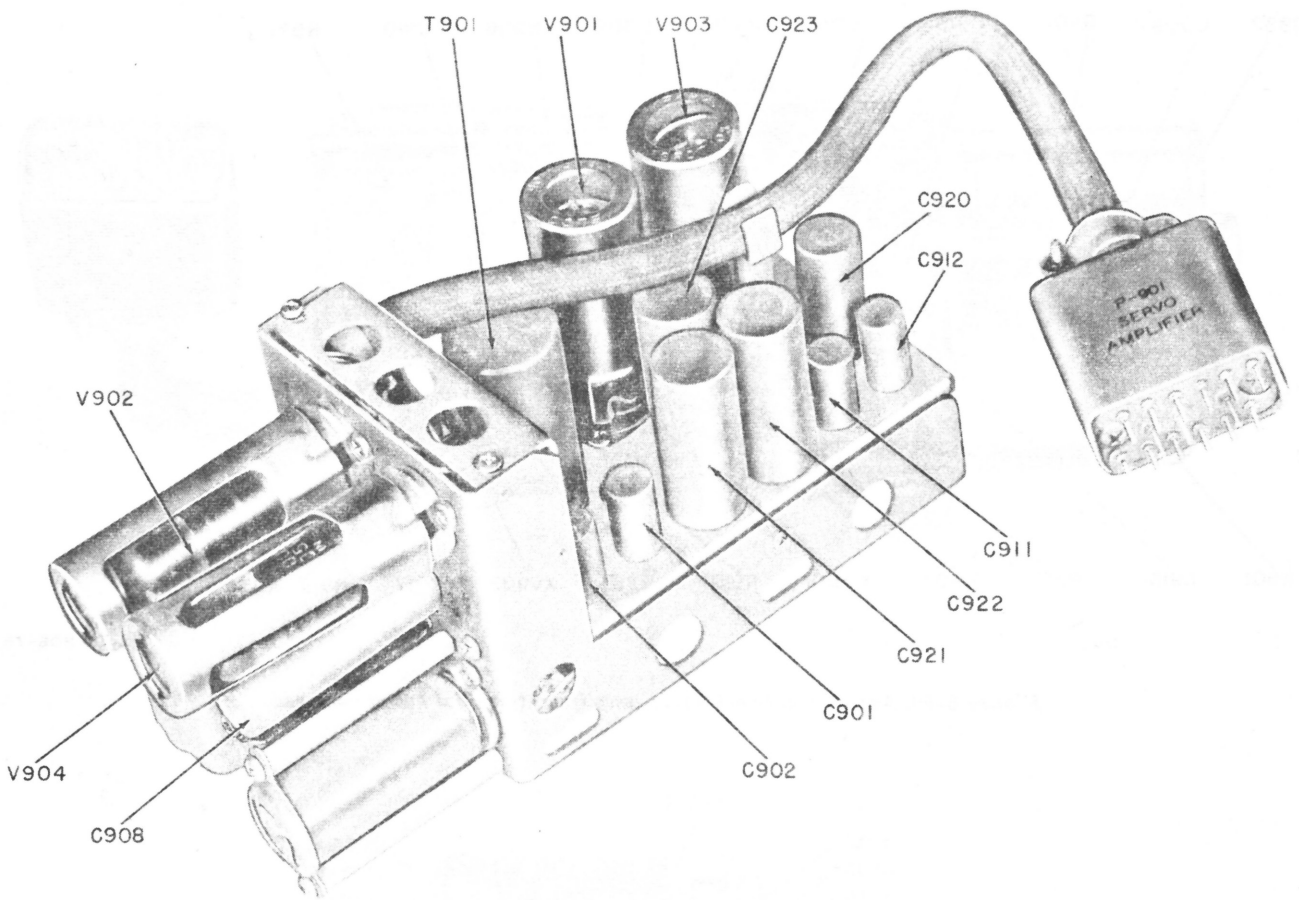

TM 806-76

Figure 2-27. Antenna network servo amplifier, oblique side view.

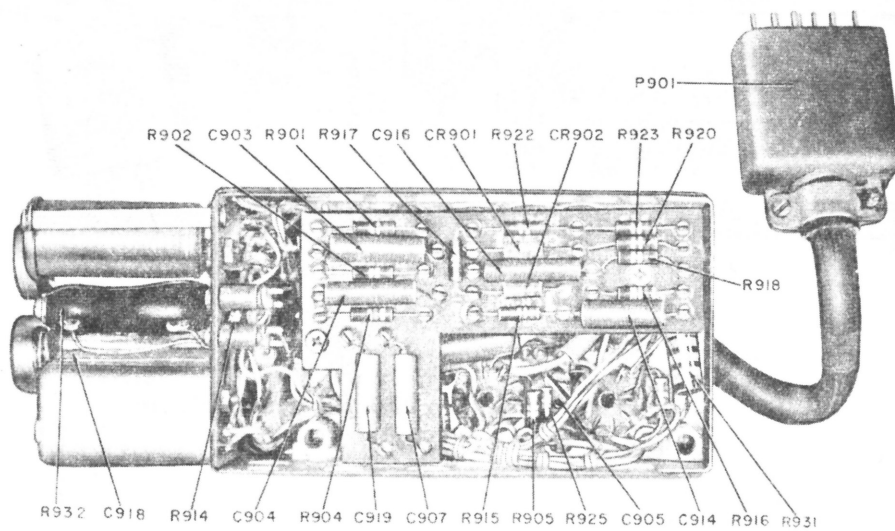

TM 806-74

Figure 2-28. Antenna network servo amplifier, bottom view.



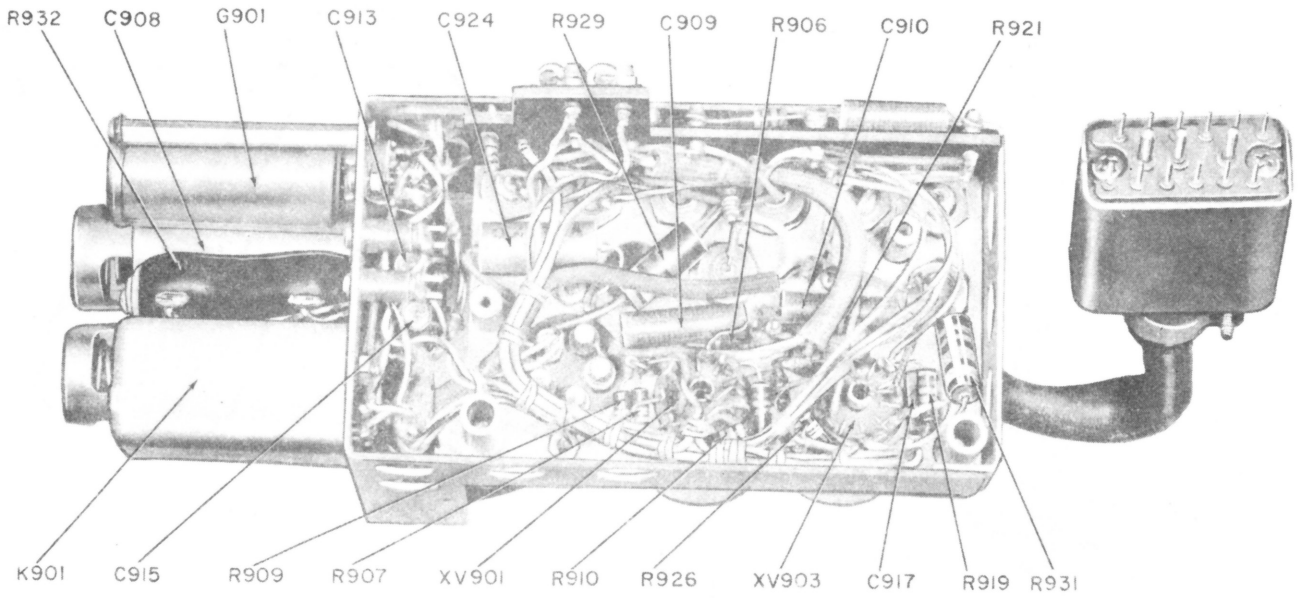

TM 806-75

Figure 2-29. Antenna network servo amplifier, terminal board removed.

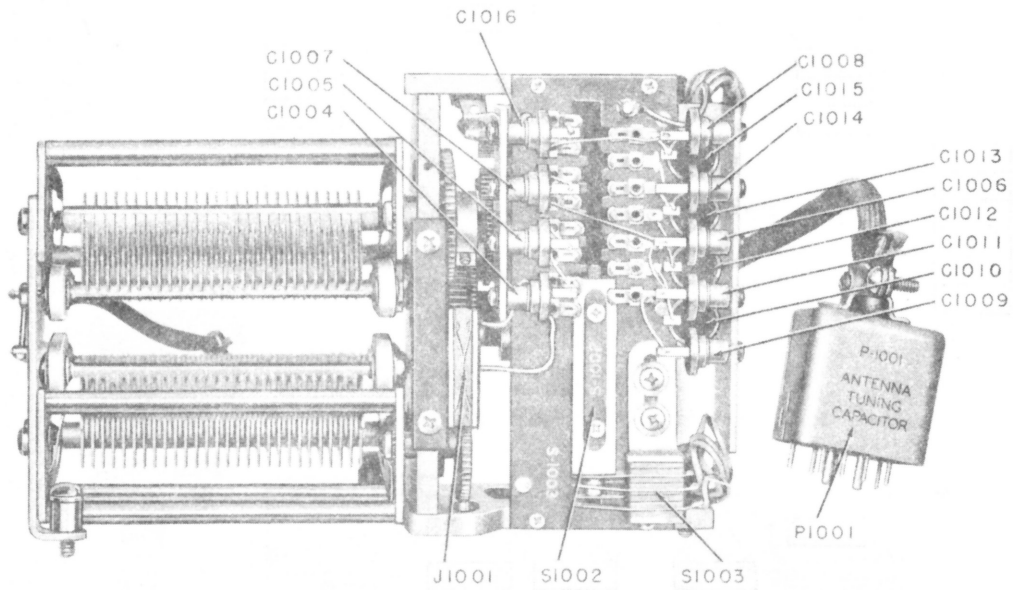

TM 806-63

Figure 2-30. Antenna tuning capacitor subchassis, right view.



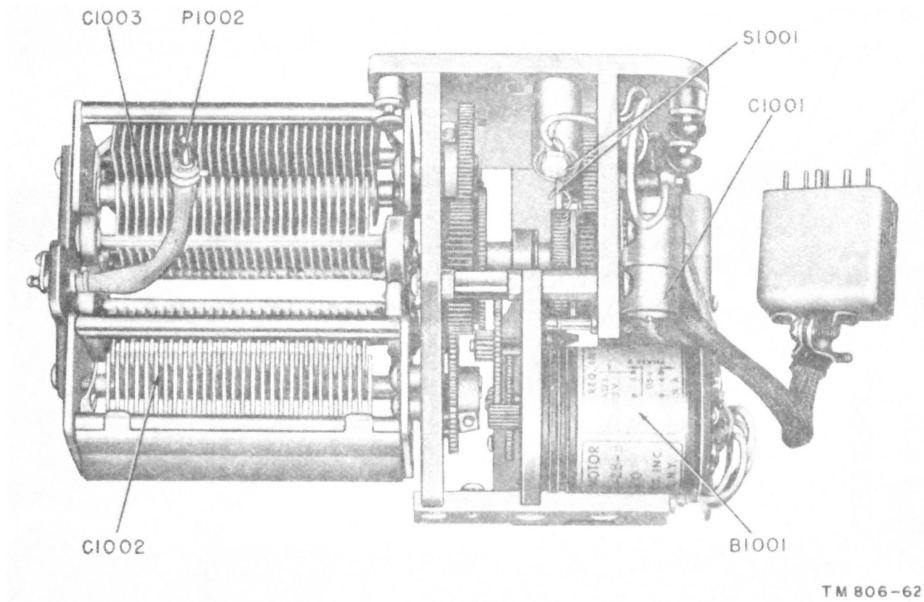

TM 806-62

Figure 2-31. Antenna tuning capacitor subchassis, left view.

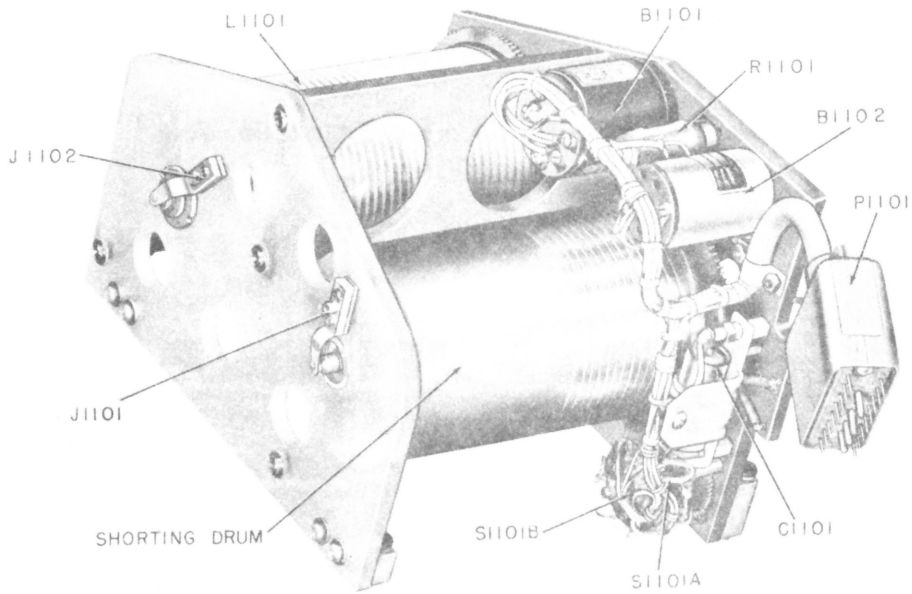

TM 806-61

Figure 2-32. Variable inductor subchassis.

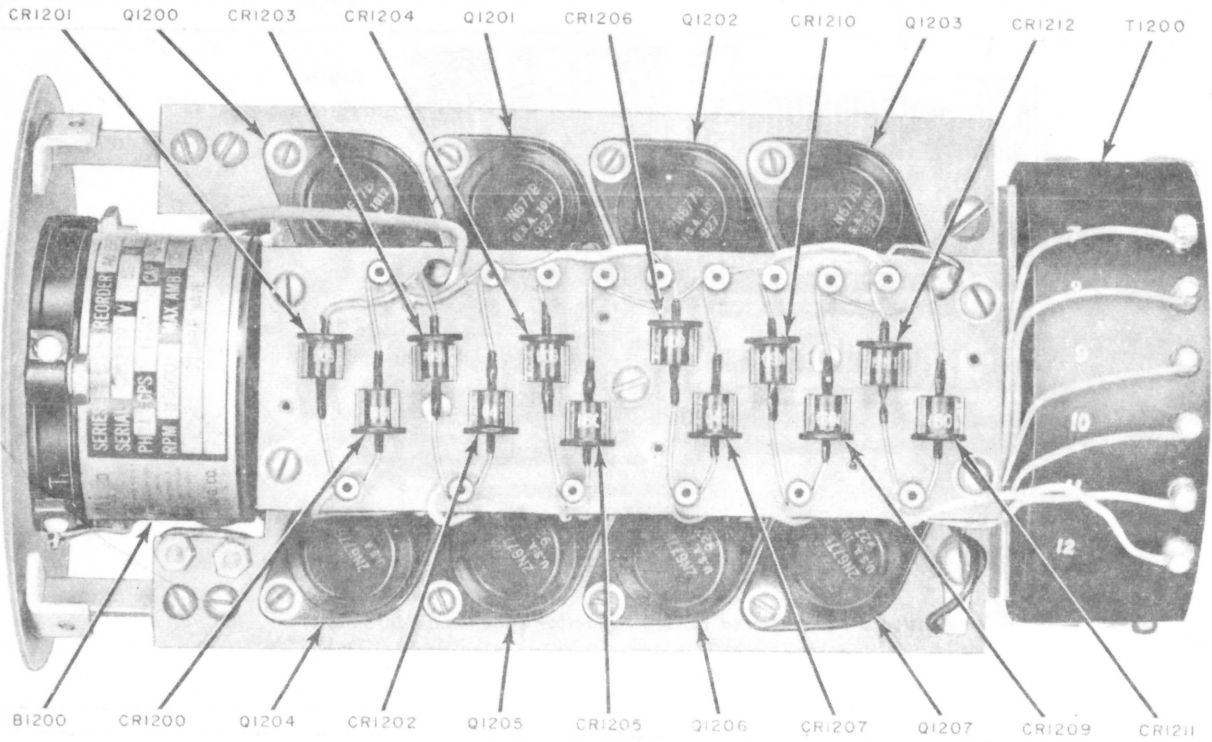

TM806-C5-14

Figure 2-33. High-voltage power supply A1200, top view.

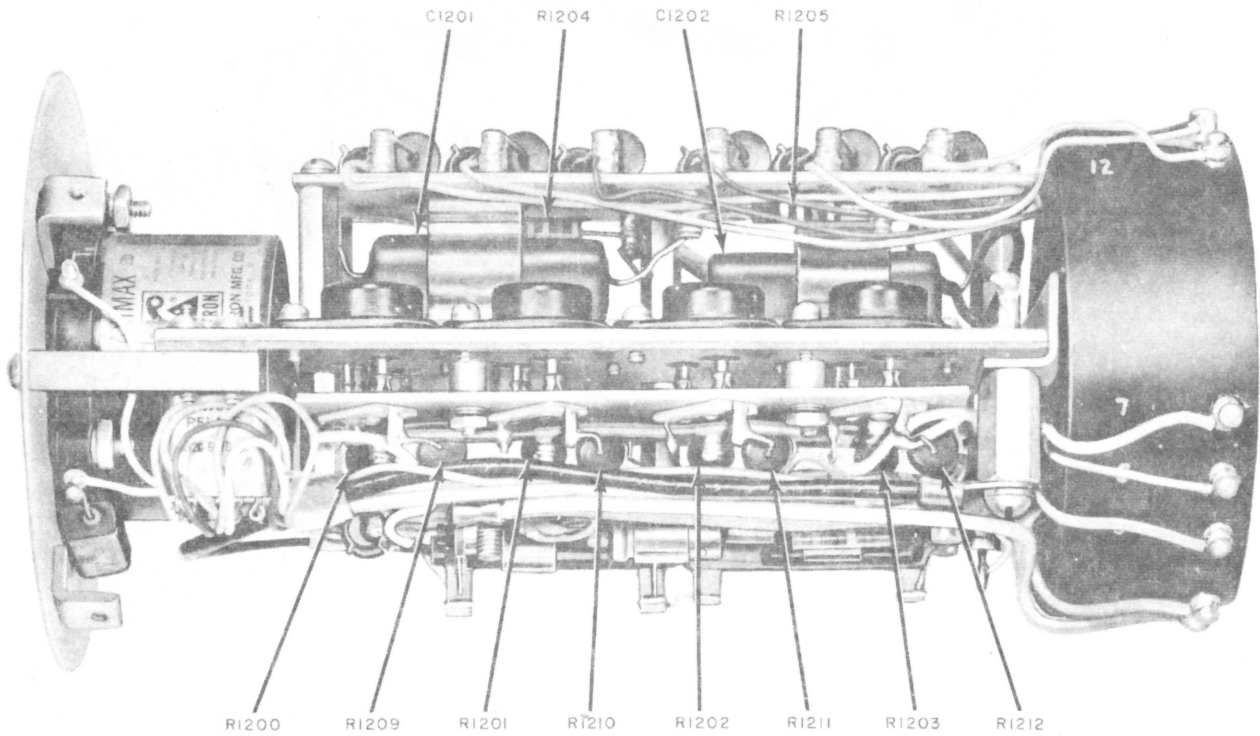

TM806-C5-15

Figure 2-34. High-voltage power supply A1200, side view.

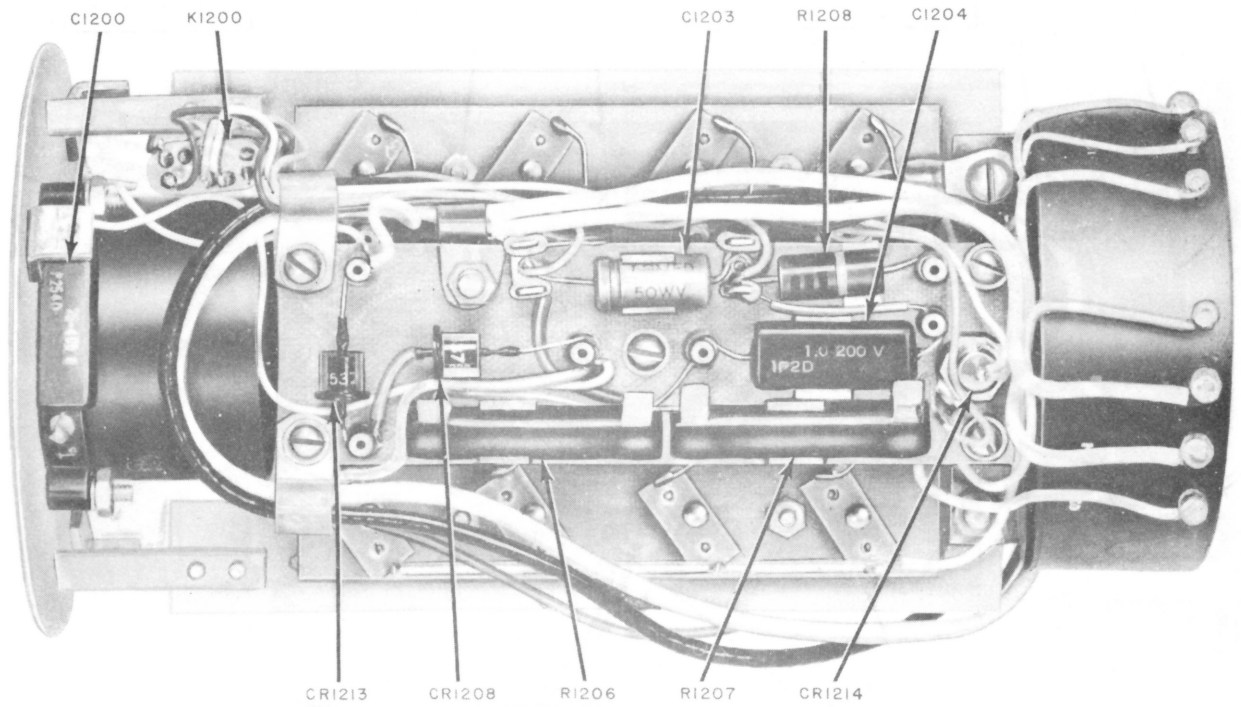

TM806-C5-16

Figure 2-35. High-voltage power supply A1200, bottom view.

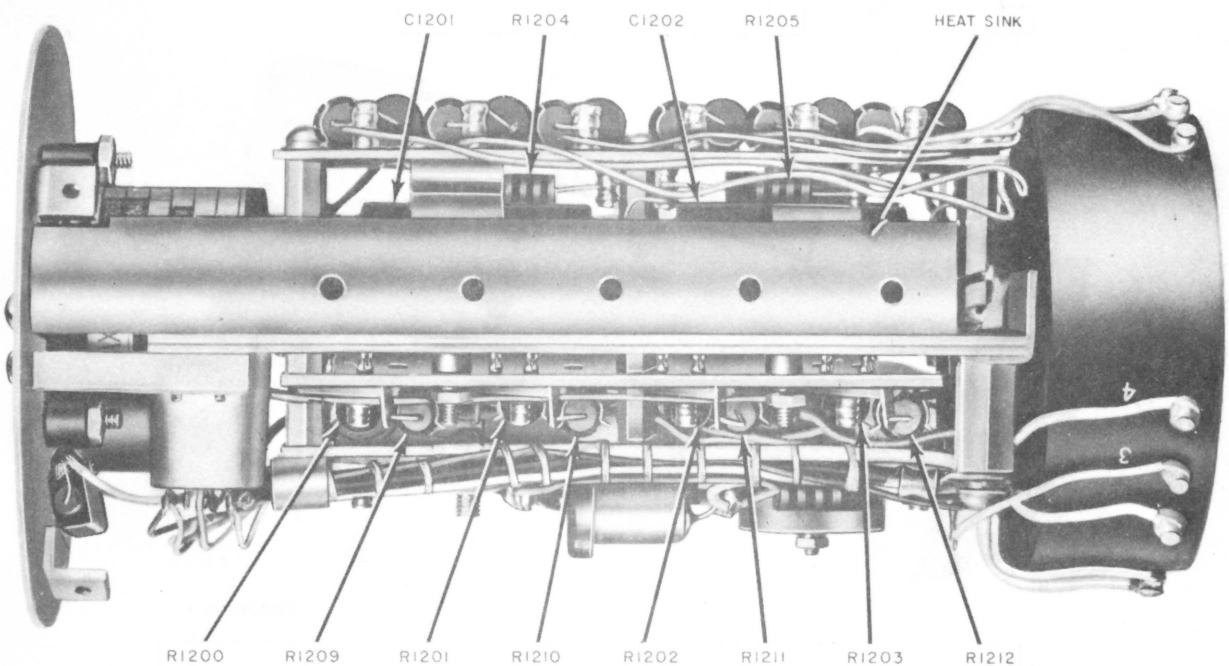

TM806-C6-3

Figure 2-36. High-voltage power supply A1200 (MOD 1), side view.

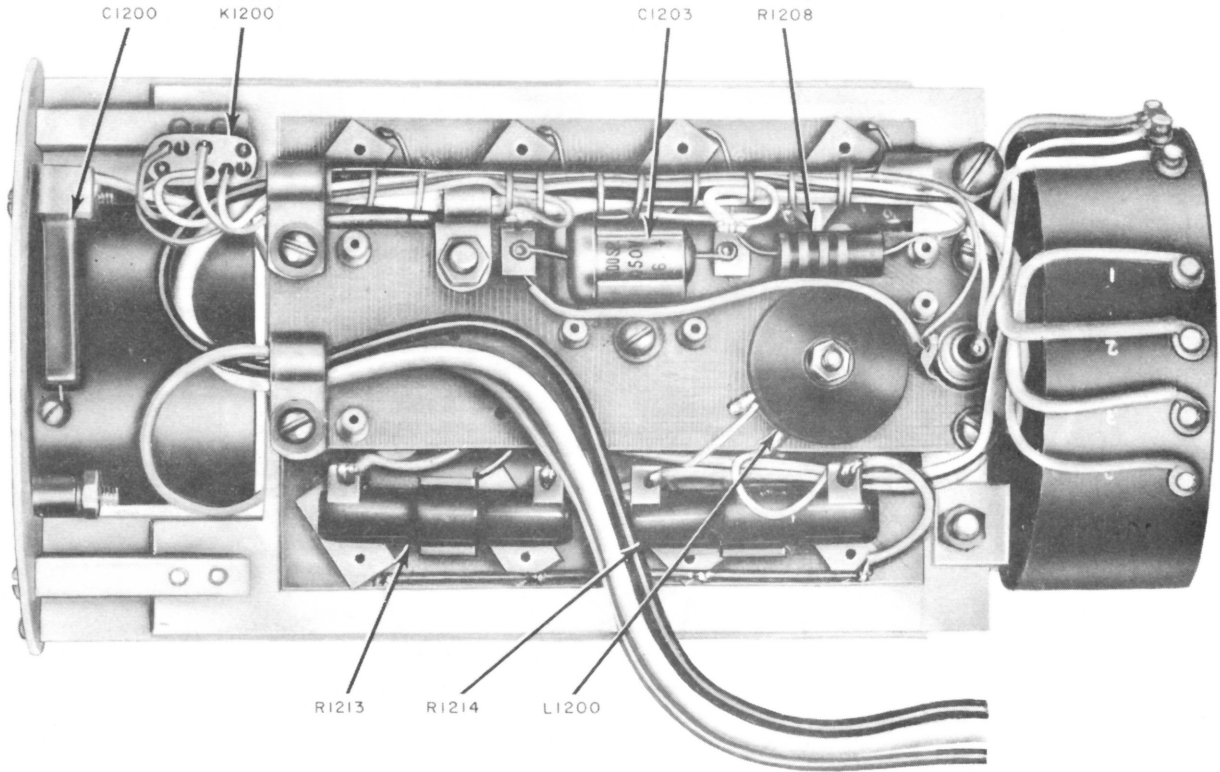

TM806-C6-4

Figure 2-37. High-voltage power supply A1200 (MOD 1), bottom view.

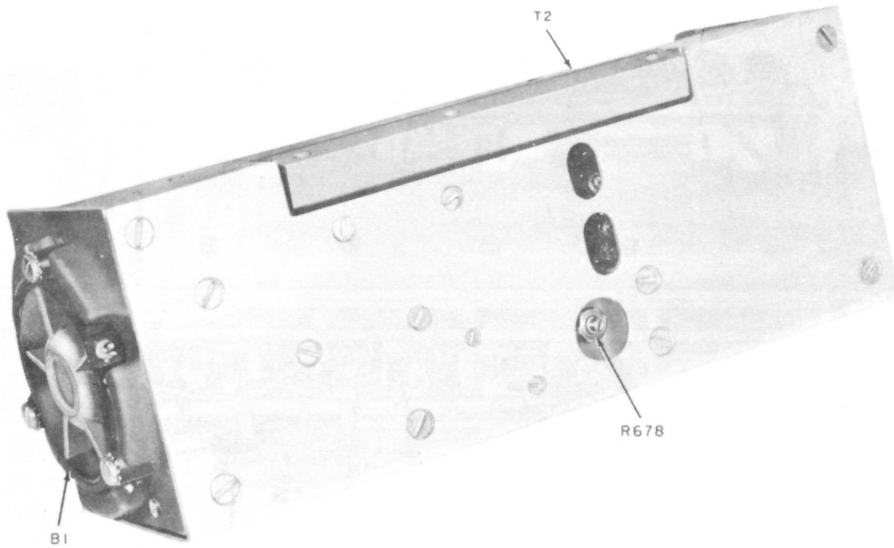

TM806-C9-6

Figure 2-38. Transistor-type low-voltage power supply, location of frequency adjustment control.

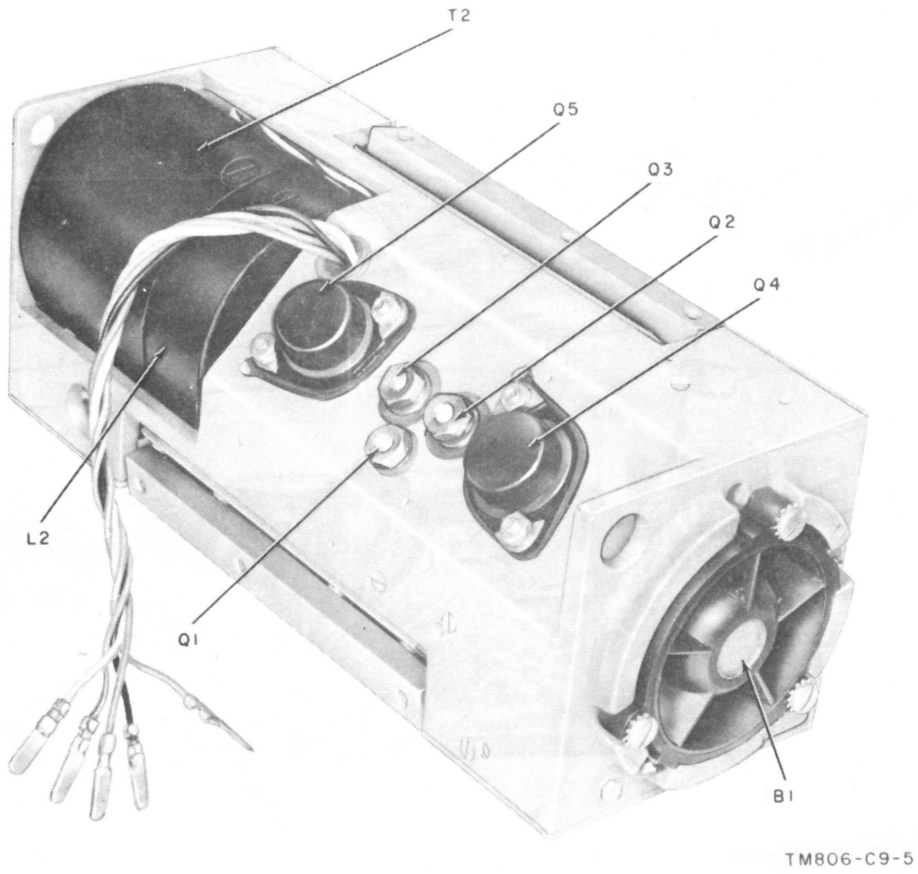
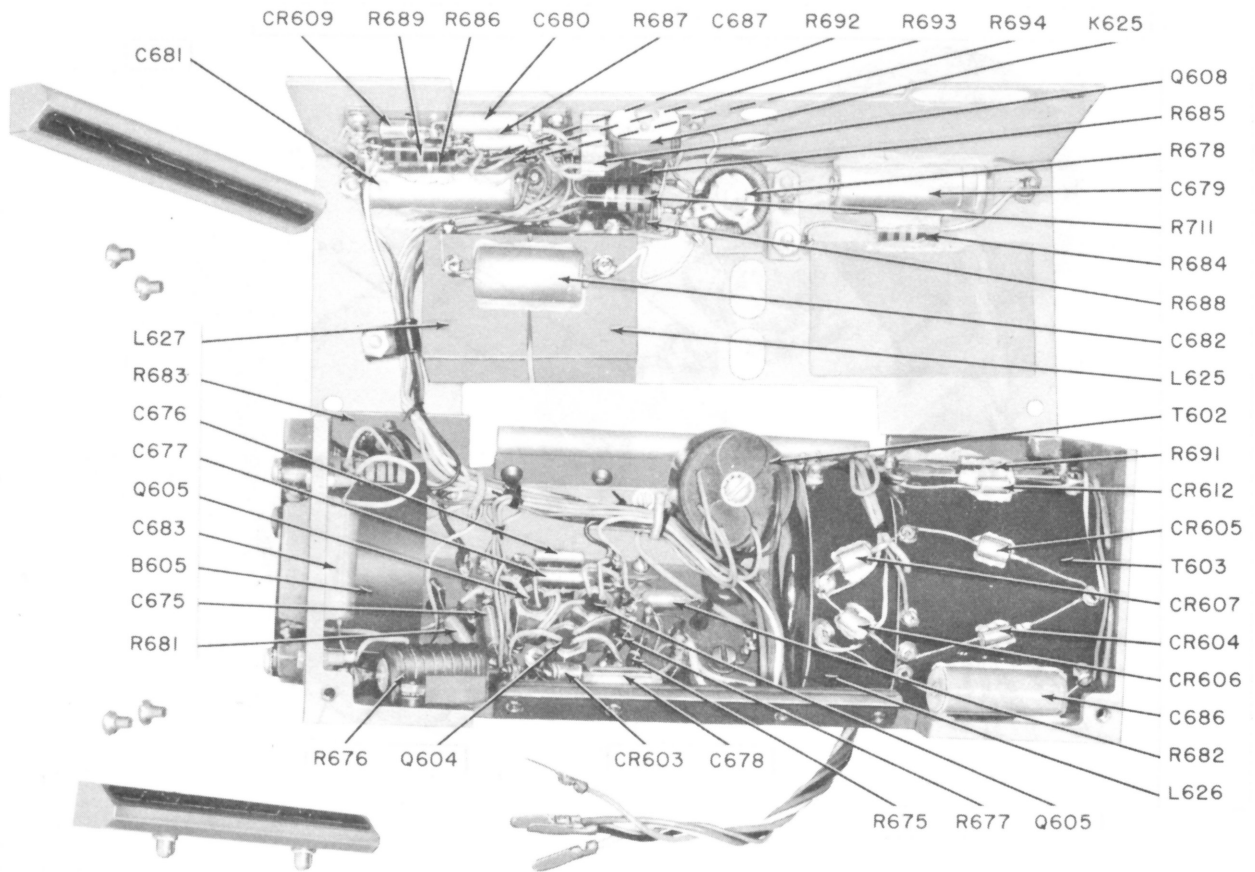
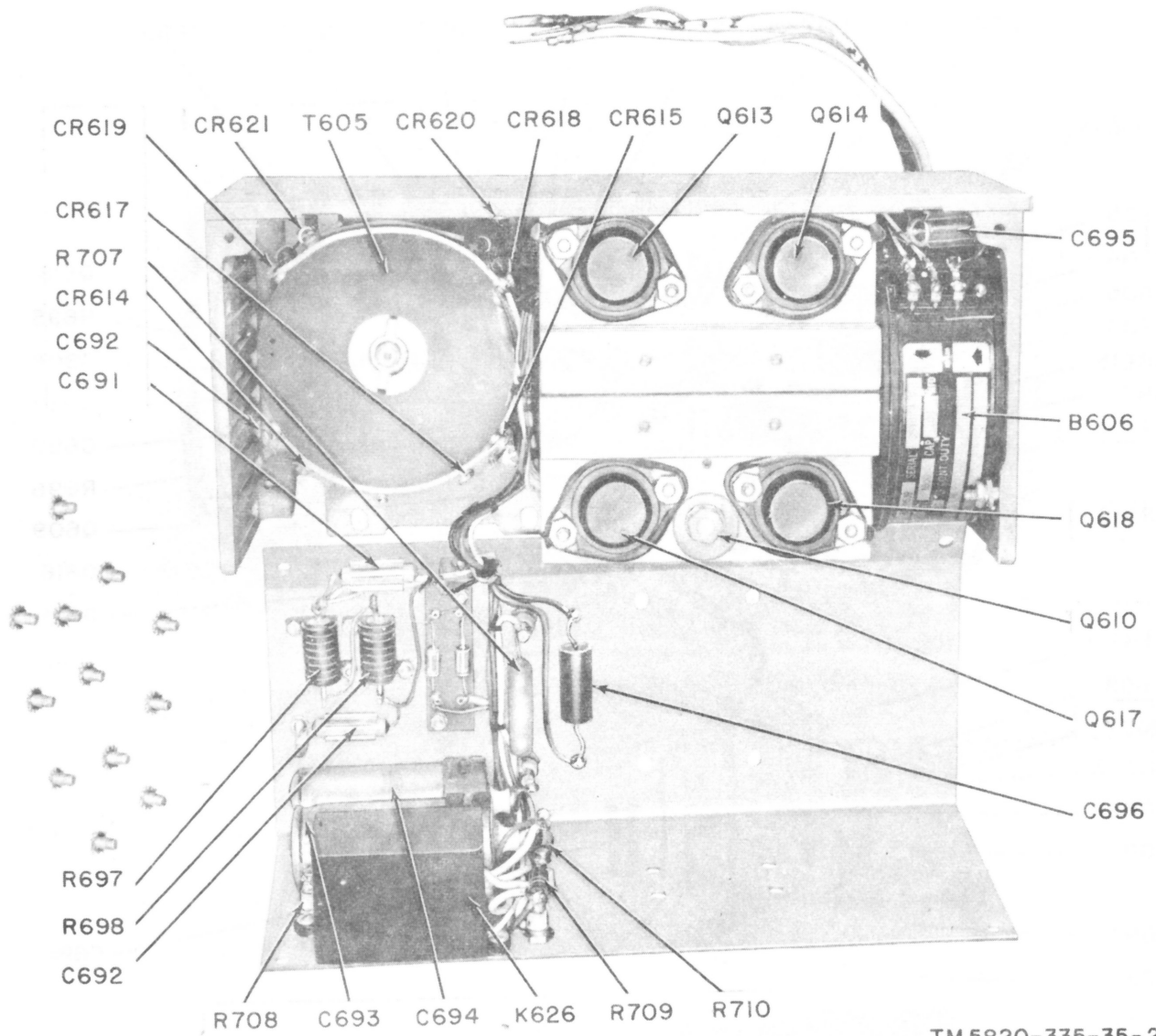

Figure 2-39. Transistor-type low-voltage power supply, bottom view.



TM806-C9-7

Figure 2-40. Transistor-type low-voltage power supply, interior view.



TM 5820-335-35-25

Figure 2-41. Transistor-type high-voltage power supply, top view, interior.



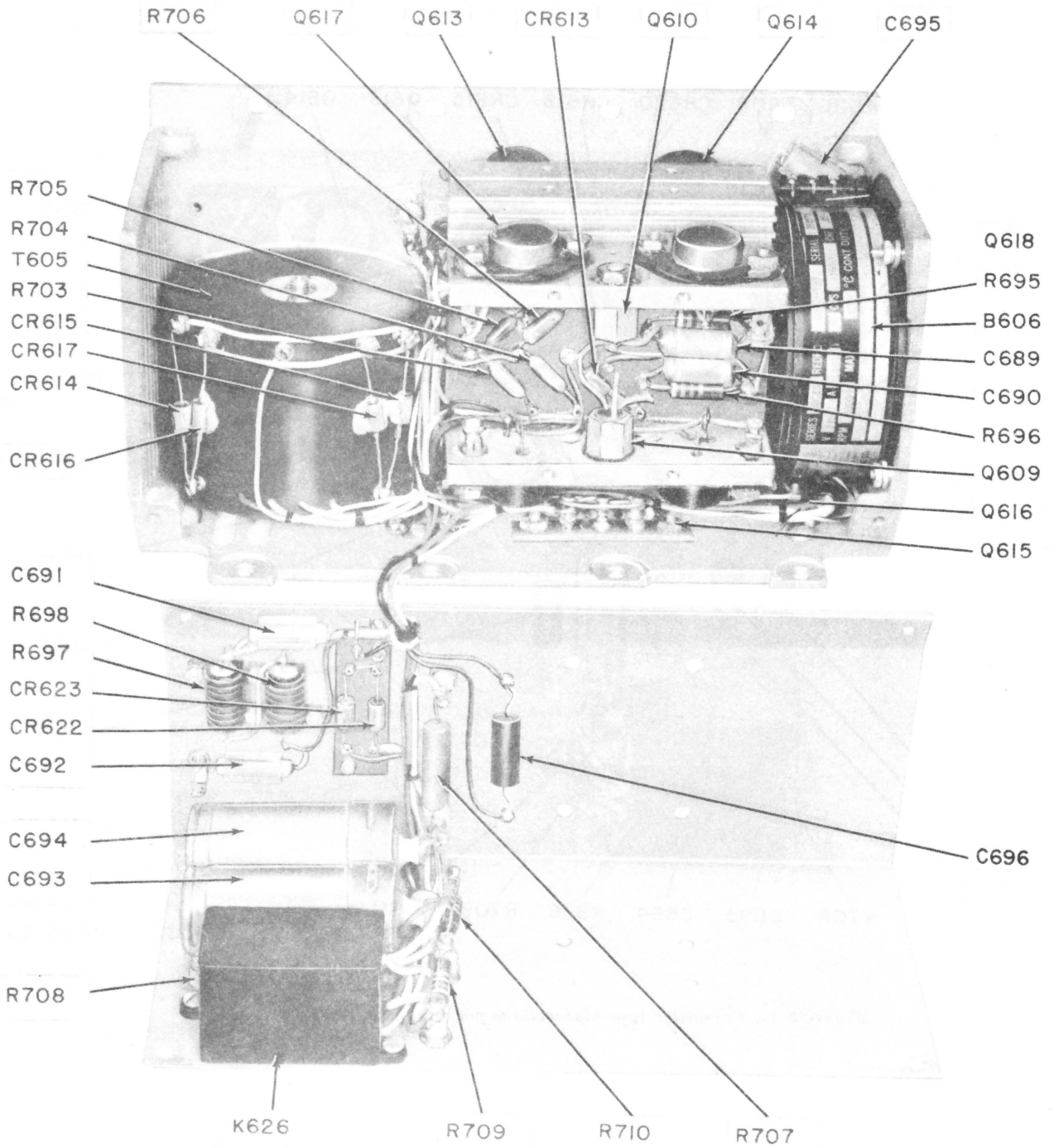

TM5820-335-35-26

Figure 2-42. Transistor-type high-voltage power supply, side view, interior.



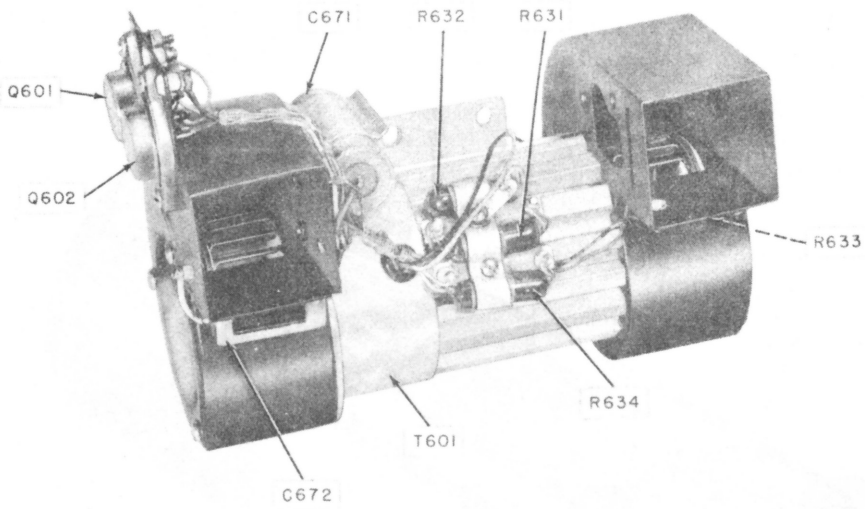

TM806-C9-11

Figure 2-43. Transistor-type exhaust blower B602, side view.

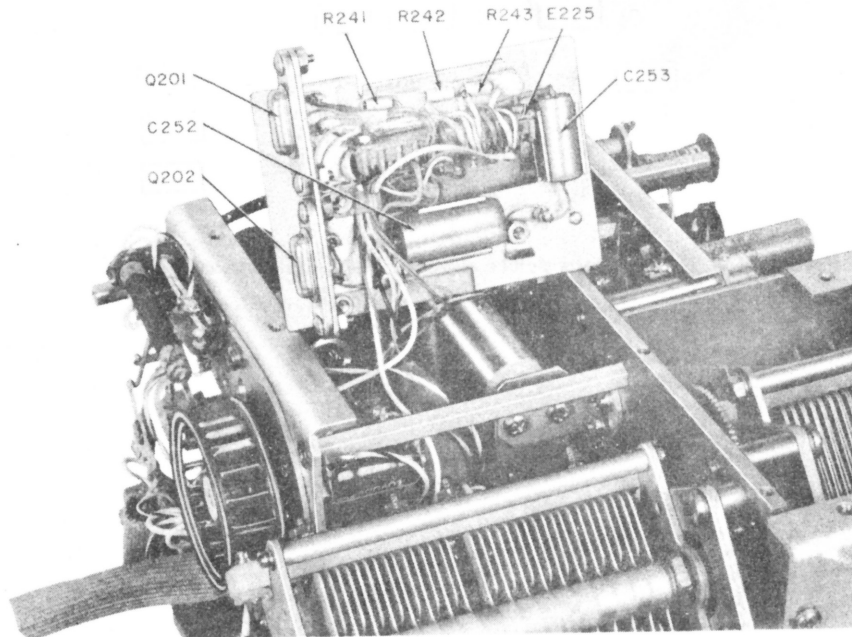

TM806-C9-12

Figure 2-44. Transistor-type pa blower B202, transistor power supply removed.

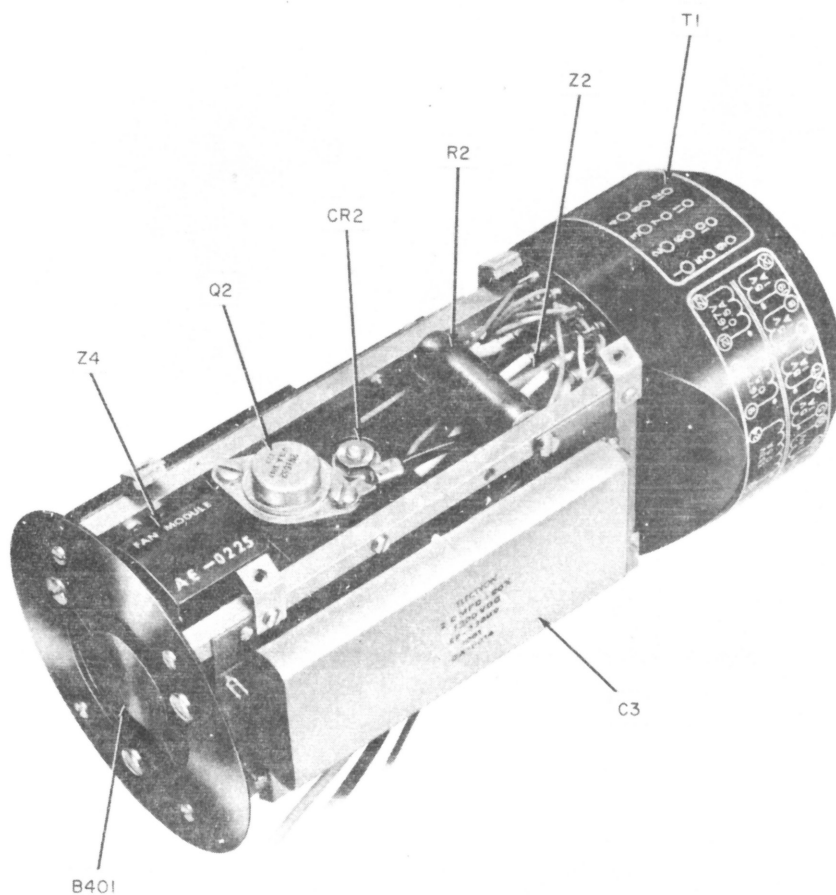

TM806-C10-6

Figure 2-45. High-voltage power supply PS602, top view, cover removed.

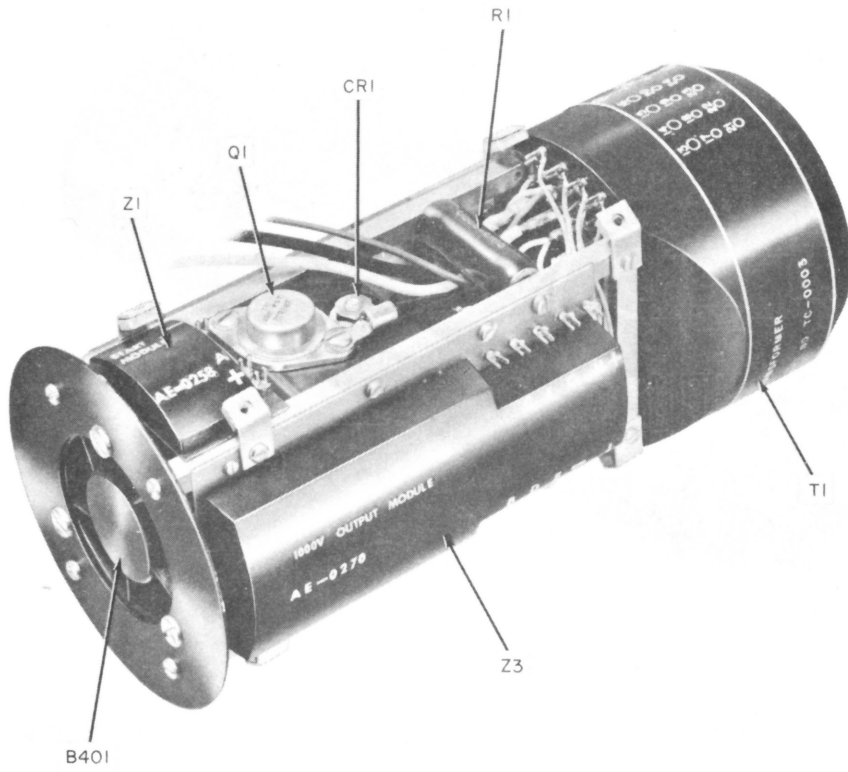

TM806-C10-7

Figure 2-46. High-voltage power supply PS601, bottom view, cover removed.

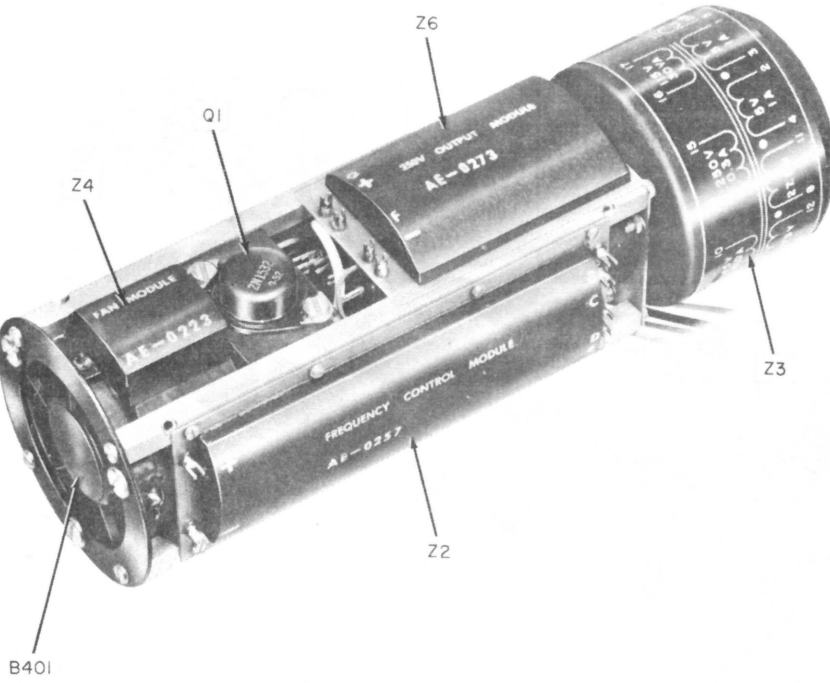

TM806-C10-8

Figure 2-47. Low-voltage power supply PS601, top view, cover removed.

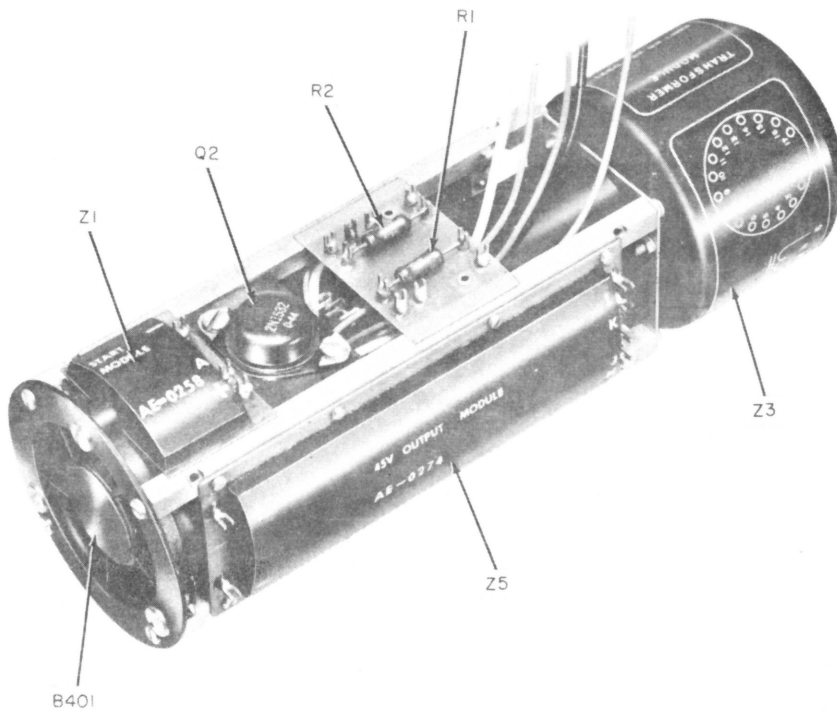

TM806-C10-9

Figure 2-48. Low-voltage power supply PS601, bottom view, cover removed.

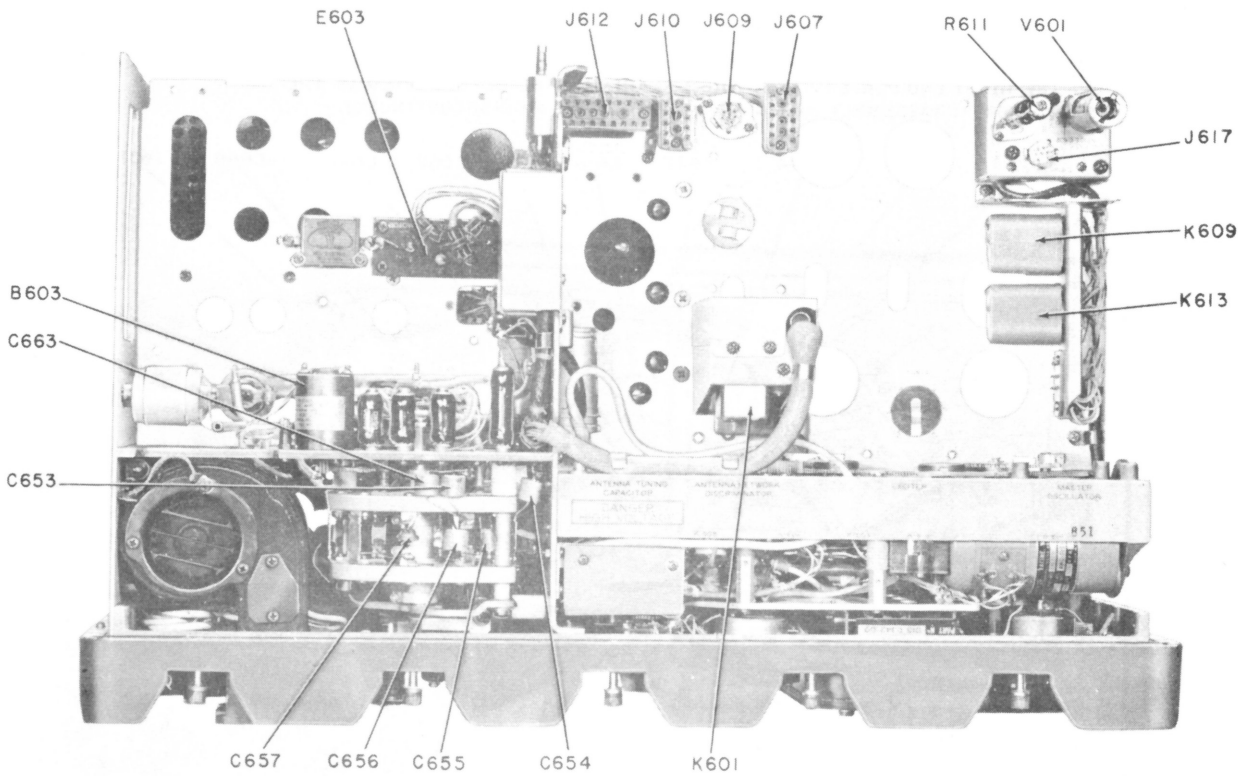

TM 806-99

Figure 2-49. Main frame, top view.

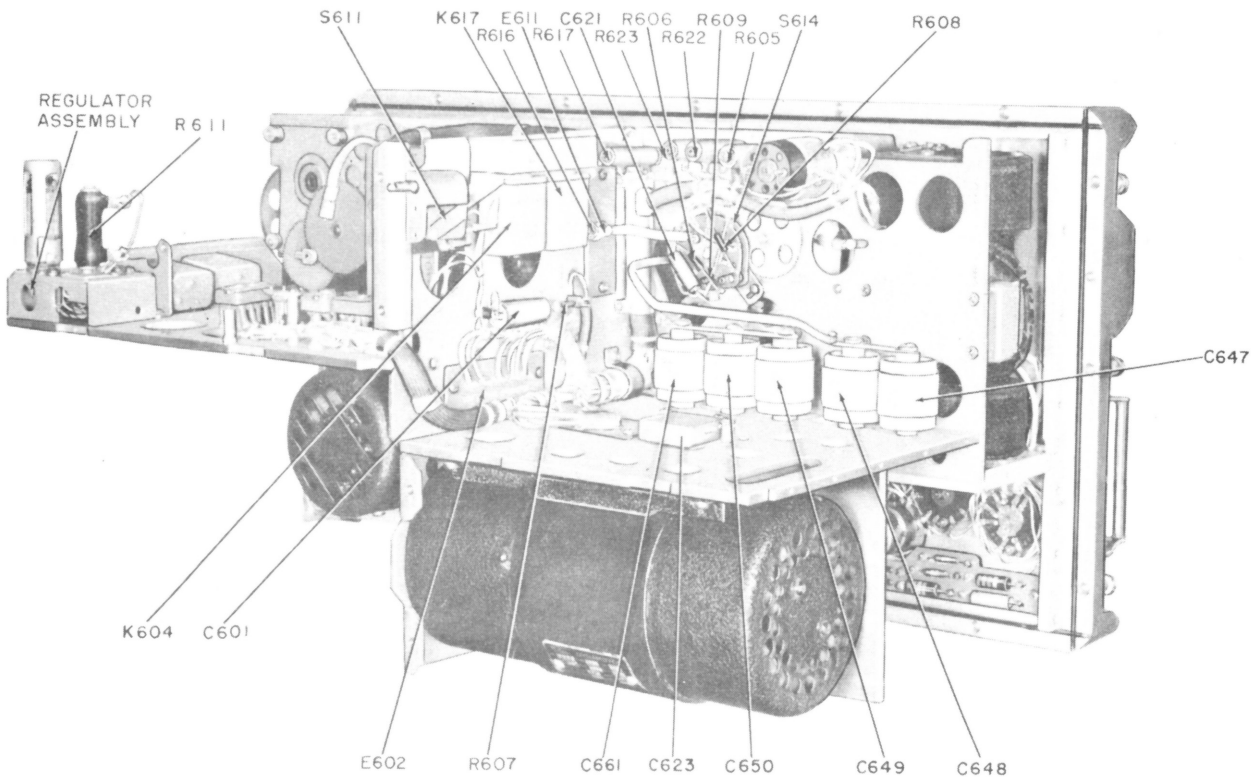

TM 806-100

Figure 2-50. Main frame, rear right view.

NOTE:

ON MAIN FRAME MOD5A AND HIGHER, A PERFORATED METAL, RF SHIELD IS ADDED TO THE RIGHT END PLATE (VIEWED FROM REAR), AND THE BOTTOM VIEW OF THE REGULATOR SUBASSEMBLY APPEARS AS SHOWN IN FIGURE 2-51(CONTINUED).

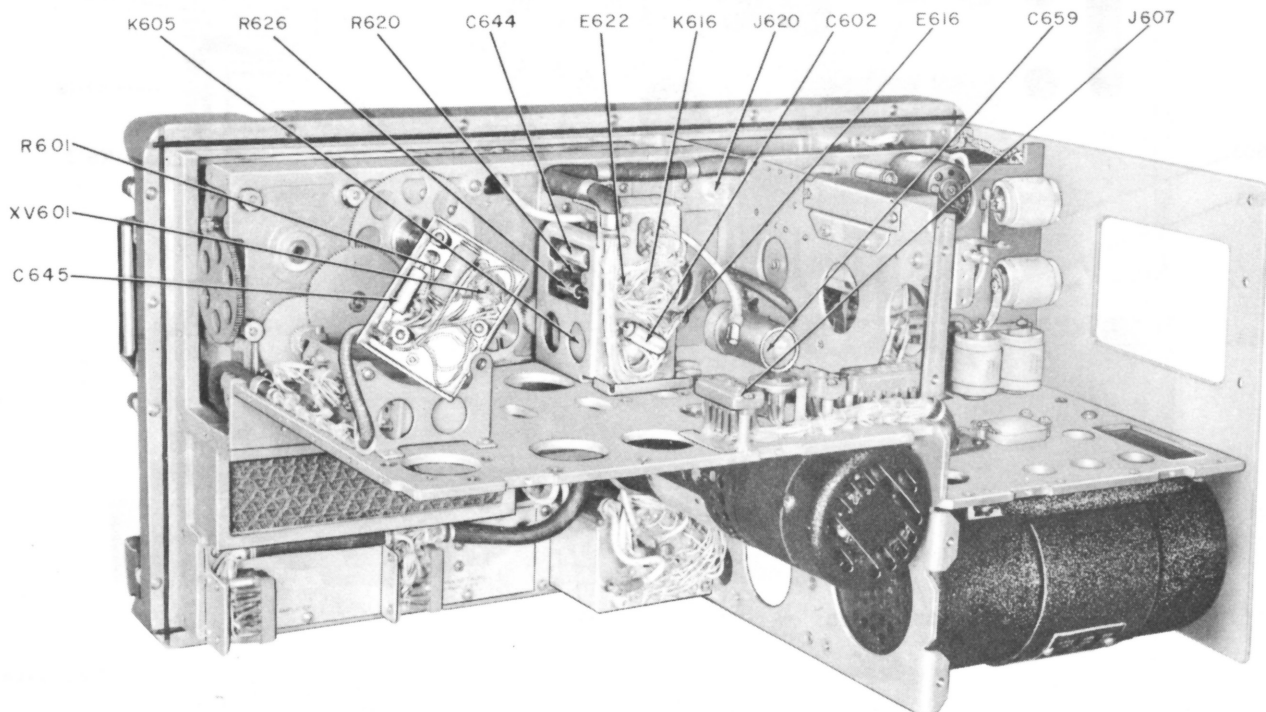

TM 5820-335-35-27

Figure 2-51. Main frame, regulator subassembly removed.

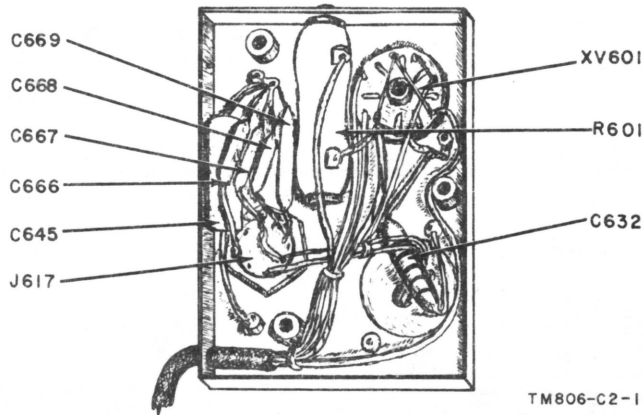

Figure 2-52. Main frame MOD 5A and higher, bottom view of regulator assembly.

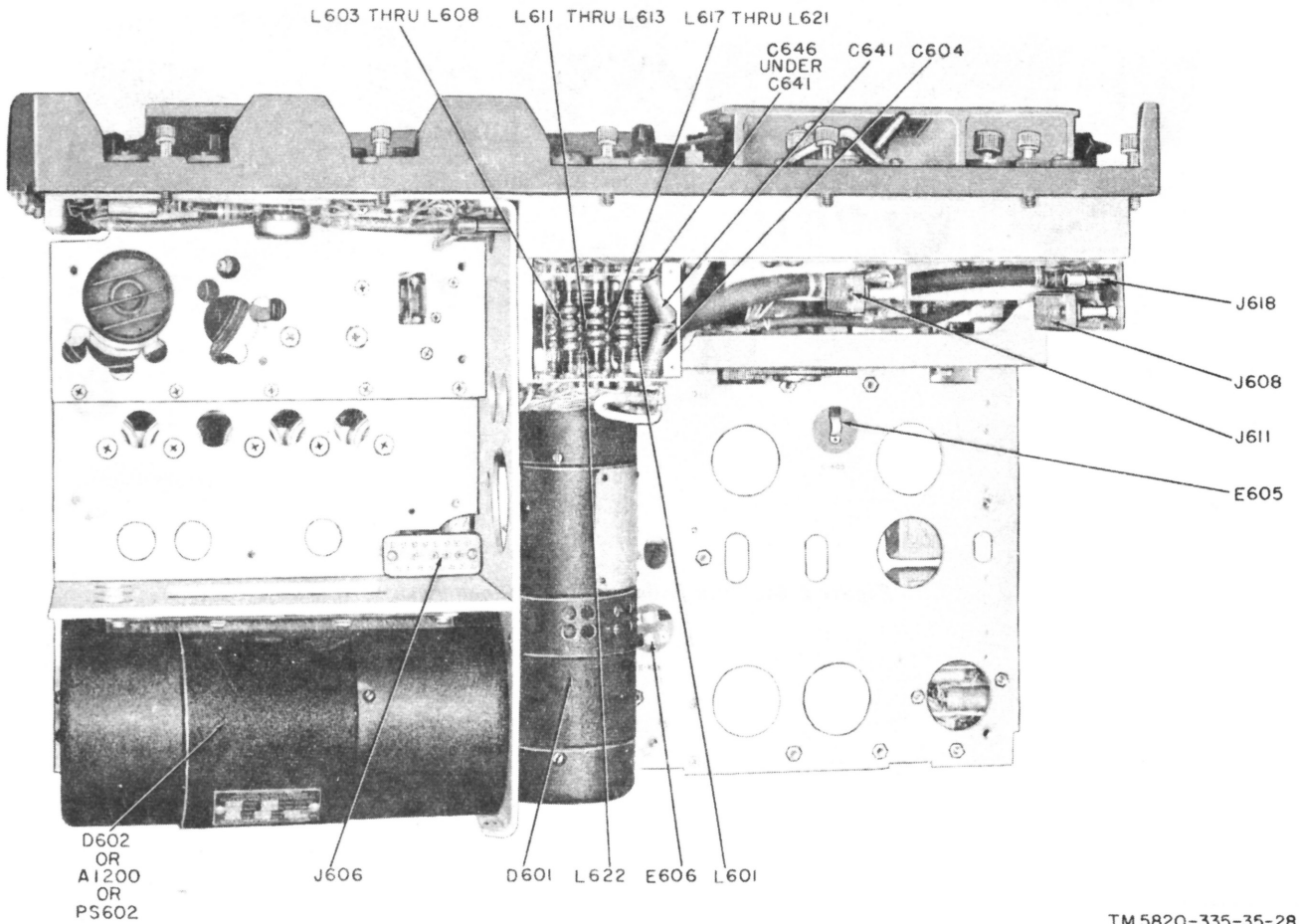
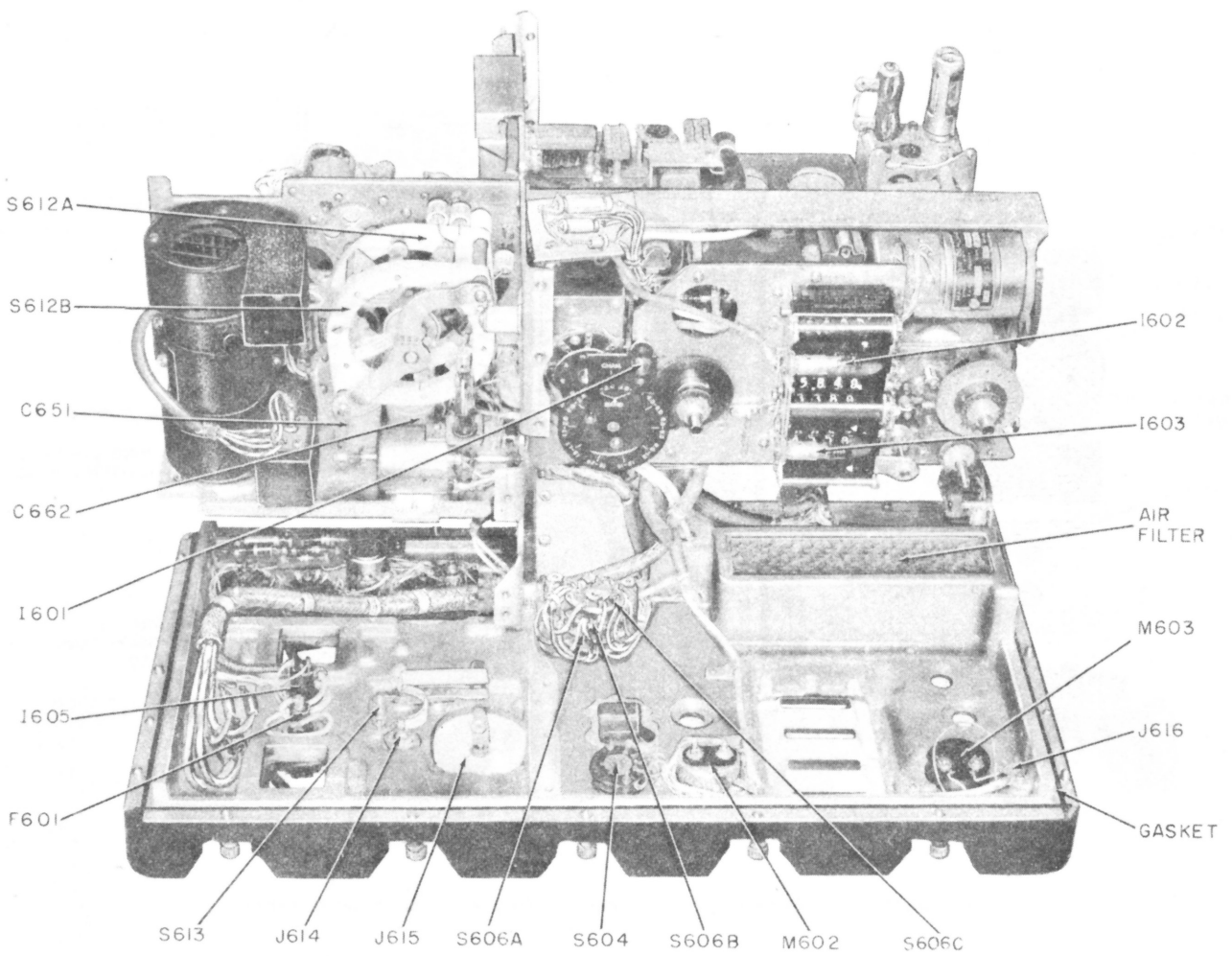

Figure 2-53. Main frame, bottom view.



TM 806-97

Figure 2-55. Main frame, front panel removed.



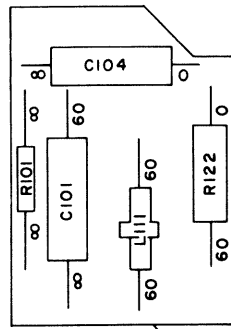

(SEE NOTES)

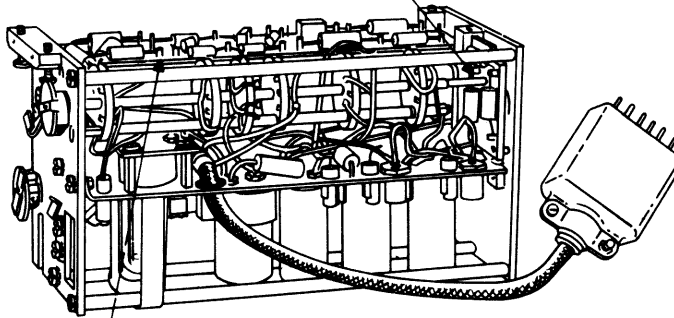

(SEE NOTES)

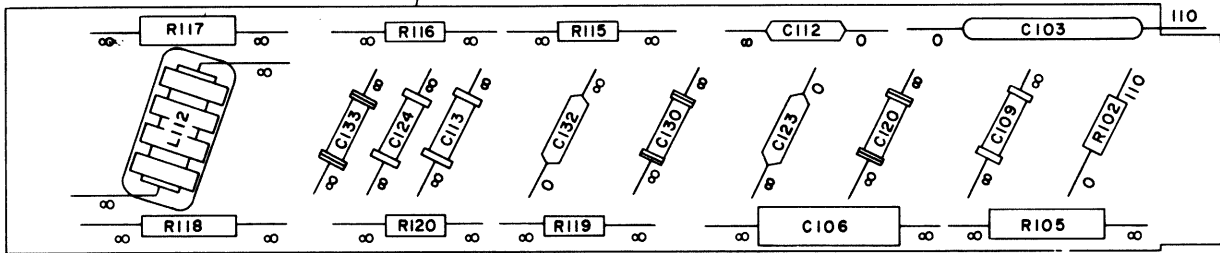

EXCITER SUBCHASSIS

NOTES

1. UNLESS OTHERWISE SHOWN, RESISTANCE IS SHOWN IN OHMS, AND ARE MEASURED FROM BOARD TERMINAL TO GROUND WITH A 20,000 OHMS-PER-VOLT METER
2. RESISTANCE MEASUREMENTS ARE FOR BAND I WITH EXCITER SUBCHASSIS DISCONNECTED.
3. INFINITY READINGS MAY DROP AS LOW AS 560K DEPENDING ON THE CONDITION OF ELECTROLYTIC CAPACITOR C146

TM 806-90

Figure 2-59. Exciter subchassis, terminal board measurements.

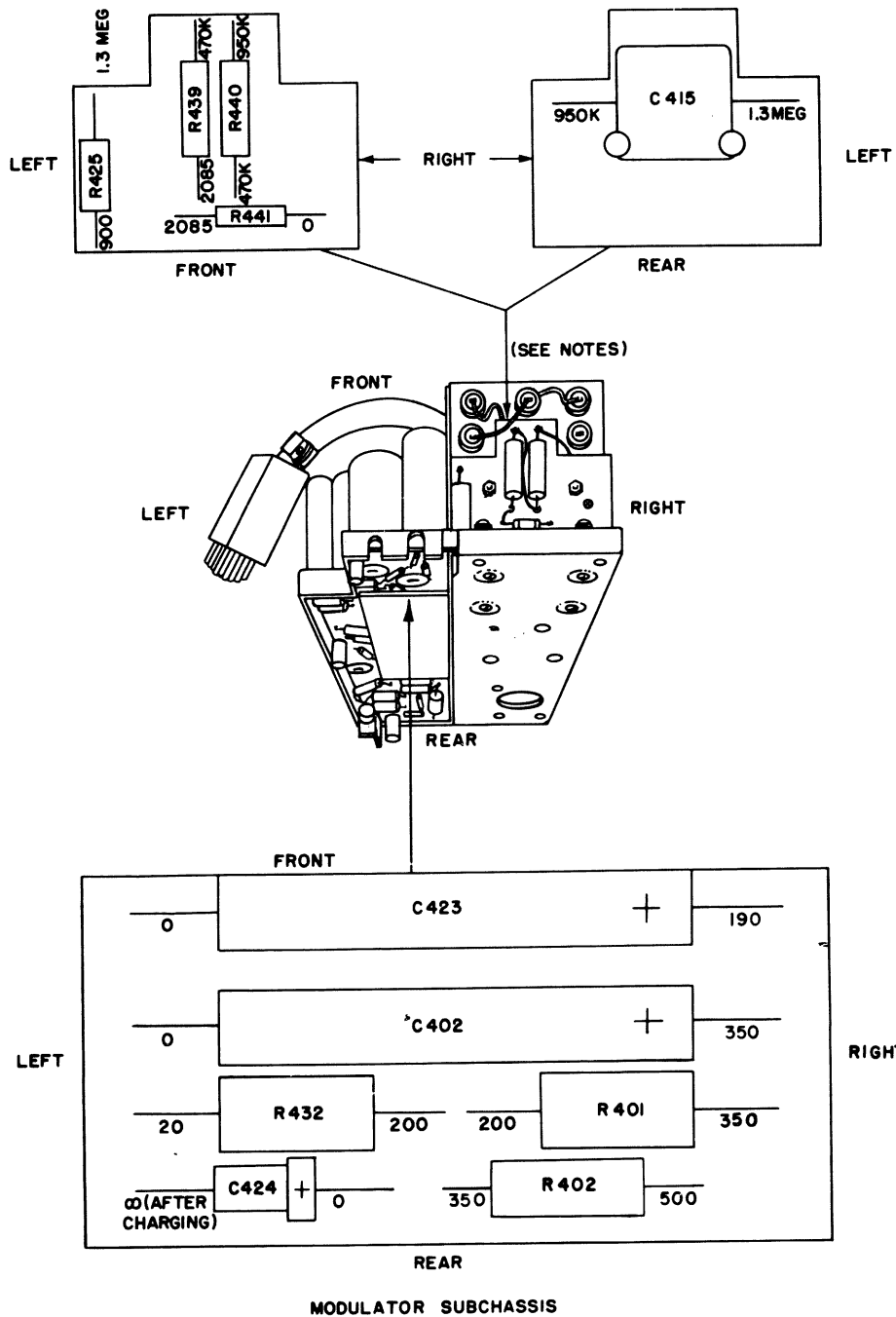

**NOTES**

1. UNLESS OTHERWISE SHOWN:  
RESISTANCE IS IN OHMS, AND ARE MEASURED FROM BOARD  
TERMINAL TO GROUND WITH A 20,000 OHMS-PER-VOLT  
METER.
2. RESISTANCE MEASUREMENTS TAKEN WITH MODULATOR SUBCHASSIS  
DISCONNECTED FROM TRANSMITTER.

TM 806-91

Figure 2-60. Modulator subchassis, terminal board measurements.

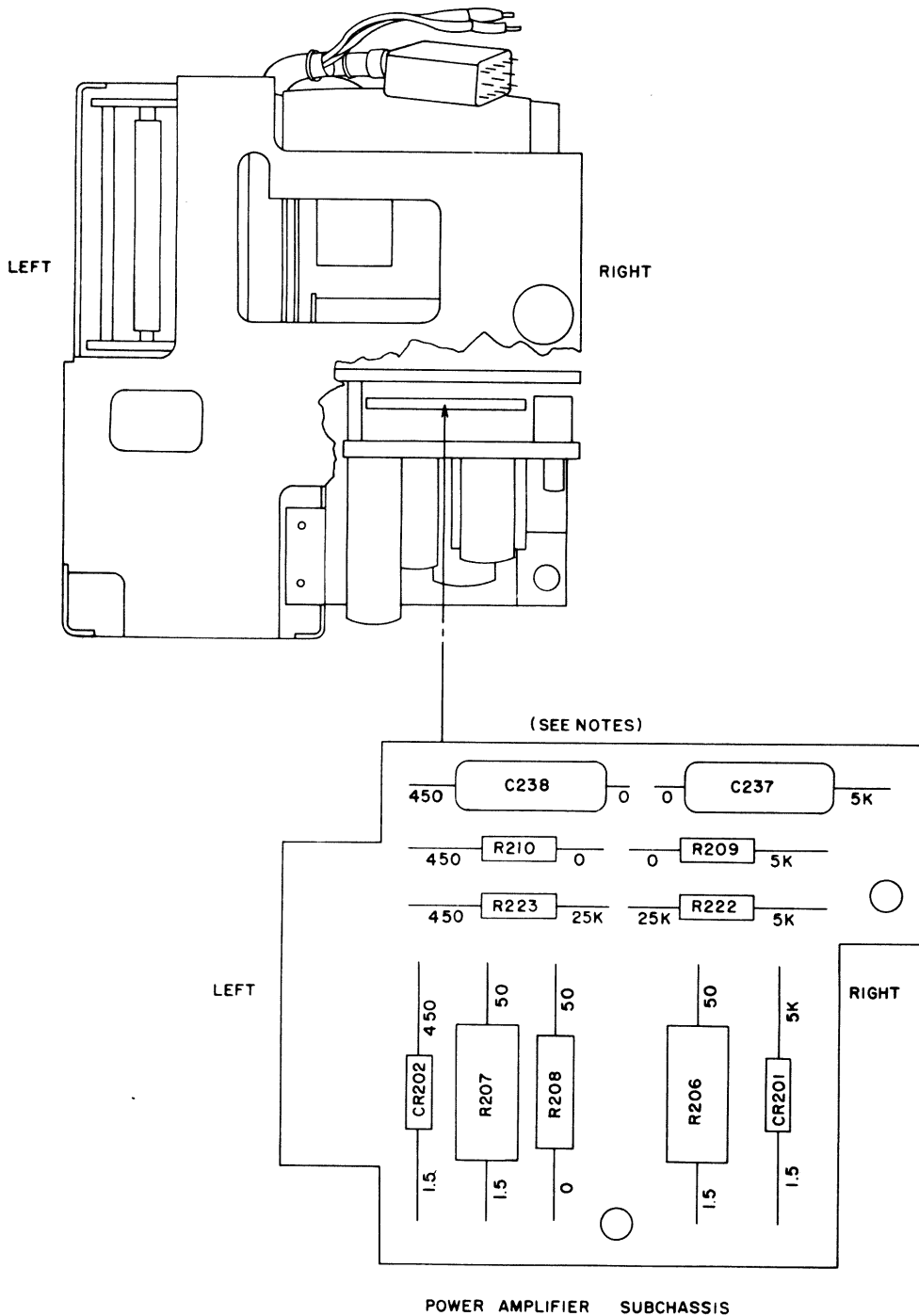

NOTES

1. UNLESS OTHERWISE SHOWN, RESISTANCE IS SHOWN IN OHMS, AND ARE MEASURED FROM BOARD TERMINAL TO GROUND WITH A 20,000 OHMS-PER-VOLT METER
2. RESISTANCE MEASUREMENTS TAKEN WITH POWER AMPLIFIER SUBCHASSIS DISCONNECTED FROM TRANSMITTER
3. ALL RESISTANCE VALUES WILL DEPEND ON POLARITY OF OHMMETER LEADS EXCEPT AT R207, R208, AND R206.

TM 806-60

Figure 2-61. Power-amplifier subchassis, terminal board measurements.

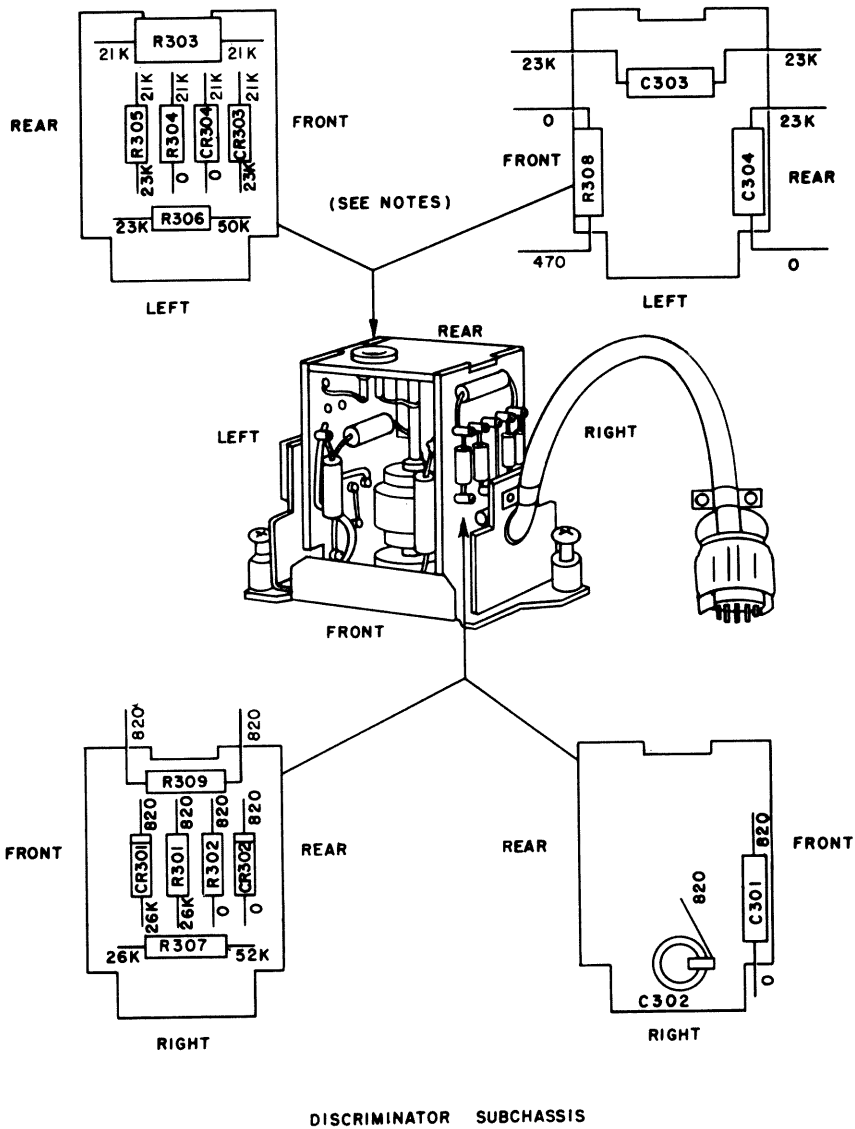

NOTES

1. UNLESS OTHERWISE SHOWN, RESISTANCE IS SHOWN IN OHMS, AND IS MEASURED FROM BOARD TERMINAL TO GROUND WITH A 20,000 OHMS-PER-VOLT METER
2. RESISTANCE MEASUREMENTS ARE TAKEN WITH DISCRIMINATOR SUBCHASSIS DISCONNECTED FROM TRANSMITTER.

TM 806-93

Figure 2-62. Discriminator subchassis, terminal board measurements.

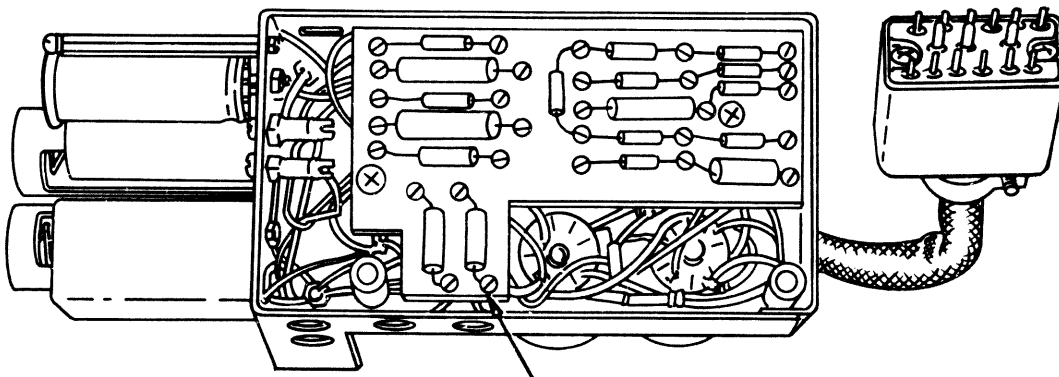

ANTENNA-NETWORK-SERVO-AMPLIFIER SUBCHASSIS

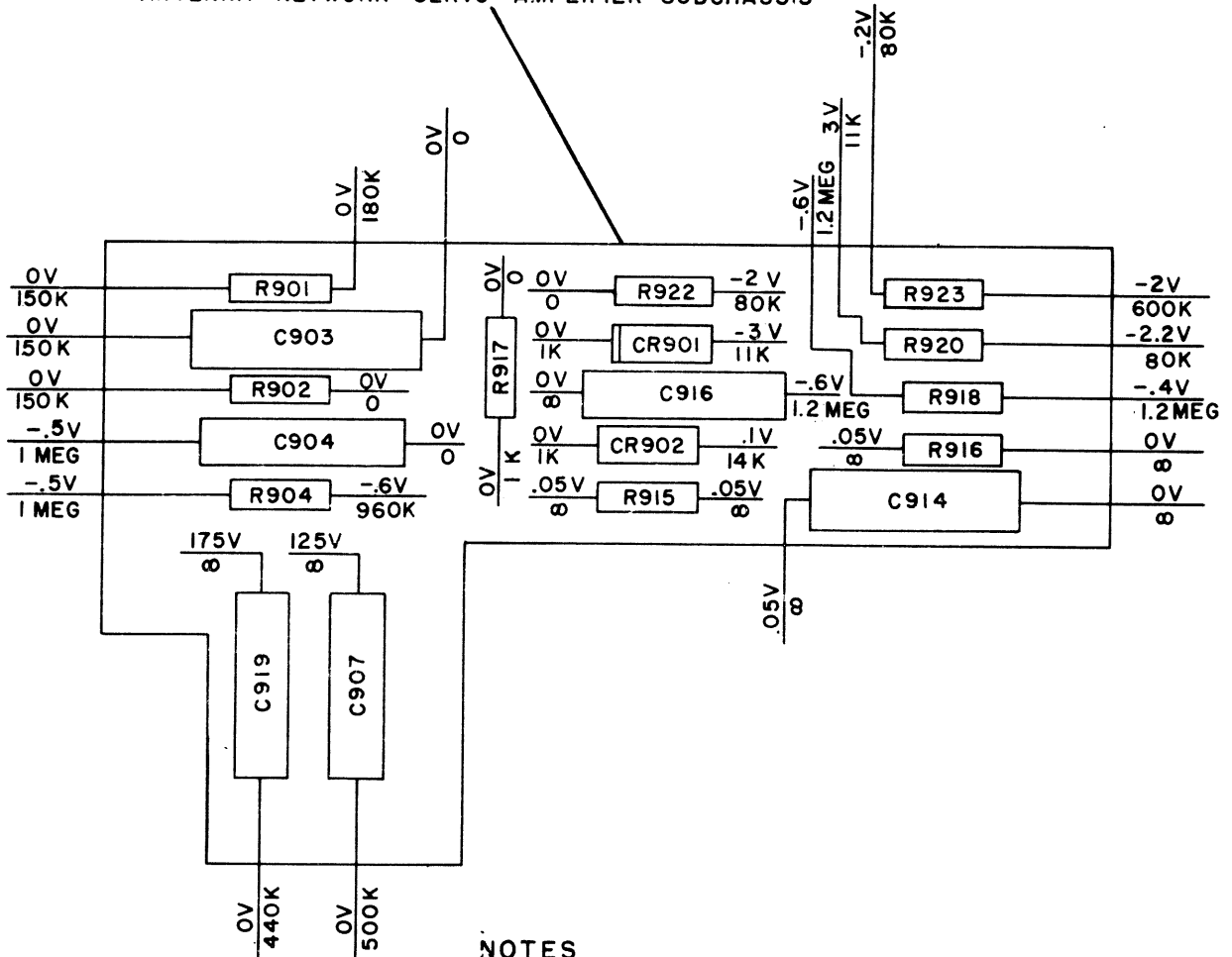

NOTES

1. UNLESS OTHERWISE SHOWN, RESISTANCE IS IN OHMS, AND IS MEASURED TO GROUND USING A 20,000 OHMS-PER-VOLT METER.
2. ALL VOLTAGES ARE DC AND ARE MEASURED TO GROUND USING A VTVM.
3. MEASUREMENTS ARE MADE WITH ANTENNA-NETWORK-SERVO-AMPLIFIER SUBCHASSIS DISCONNECTED.

TM 806-94

Figure 2-63. Antenna-network servo amplifier subchassis, terminal board measurements.

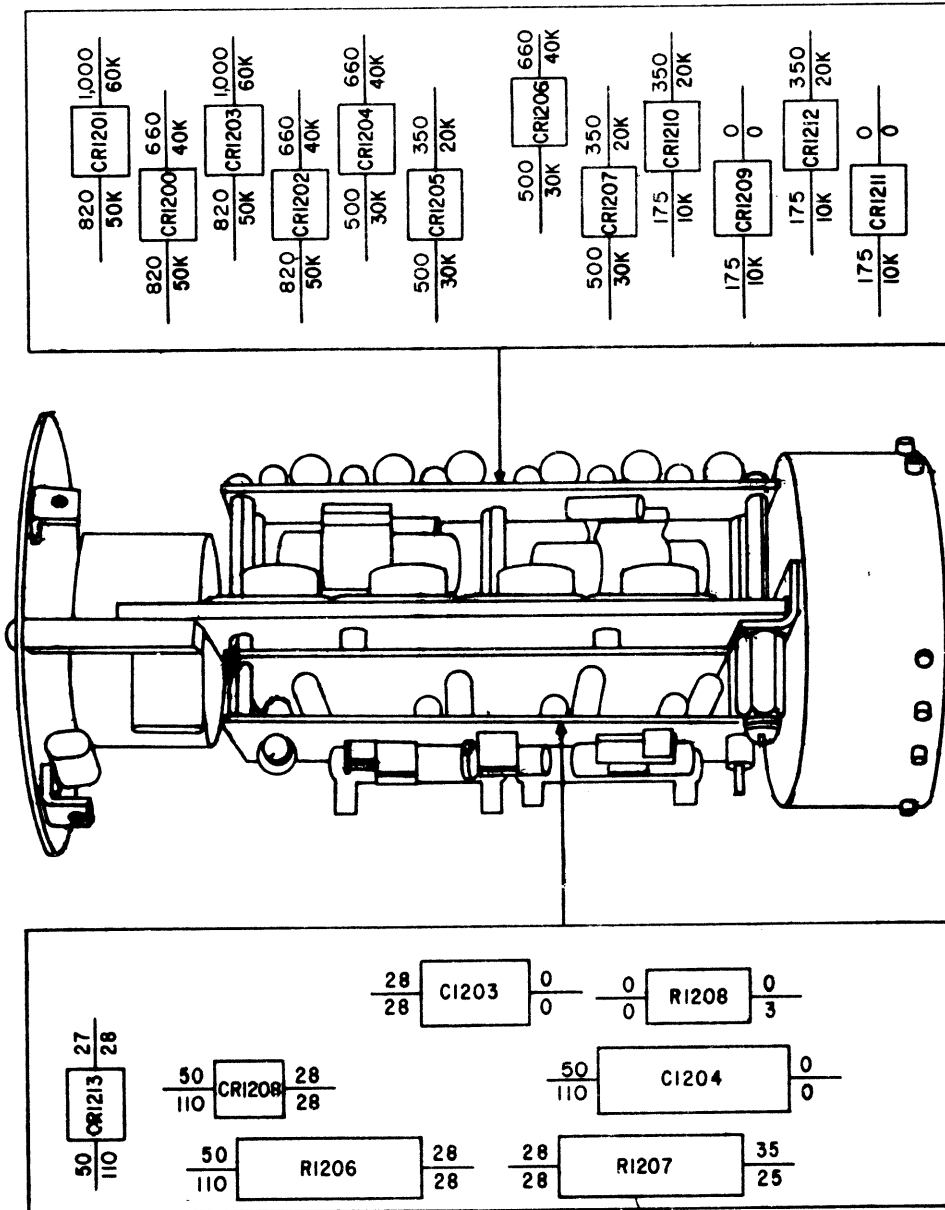

- NOTES:**
1. UNLESS OTHERWISE INDICATED, RESISTANCES ARE IN OHMS AND ARE MEASURED WITH NEGATIVE LEAD OF METER CONNECTED TO GROUND.
  2. ALL VOLTAGES ARE DC AND MEASURED TO GROUND USING A 20,000 OHMS-PER-VOLT METER.
  3. VOLTAGE MEASUREMENTS ARE MADE WITH POWER SUPPLY OPERATING UNDER LOAD CONDITIONS.

TM806-C5-17

Figure 2-64. High-voltage power supply A1200, voltage and resistance diagram.

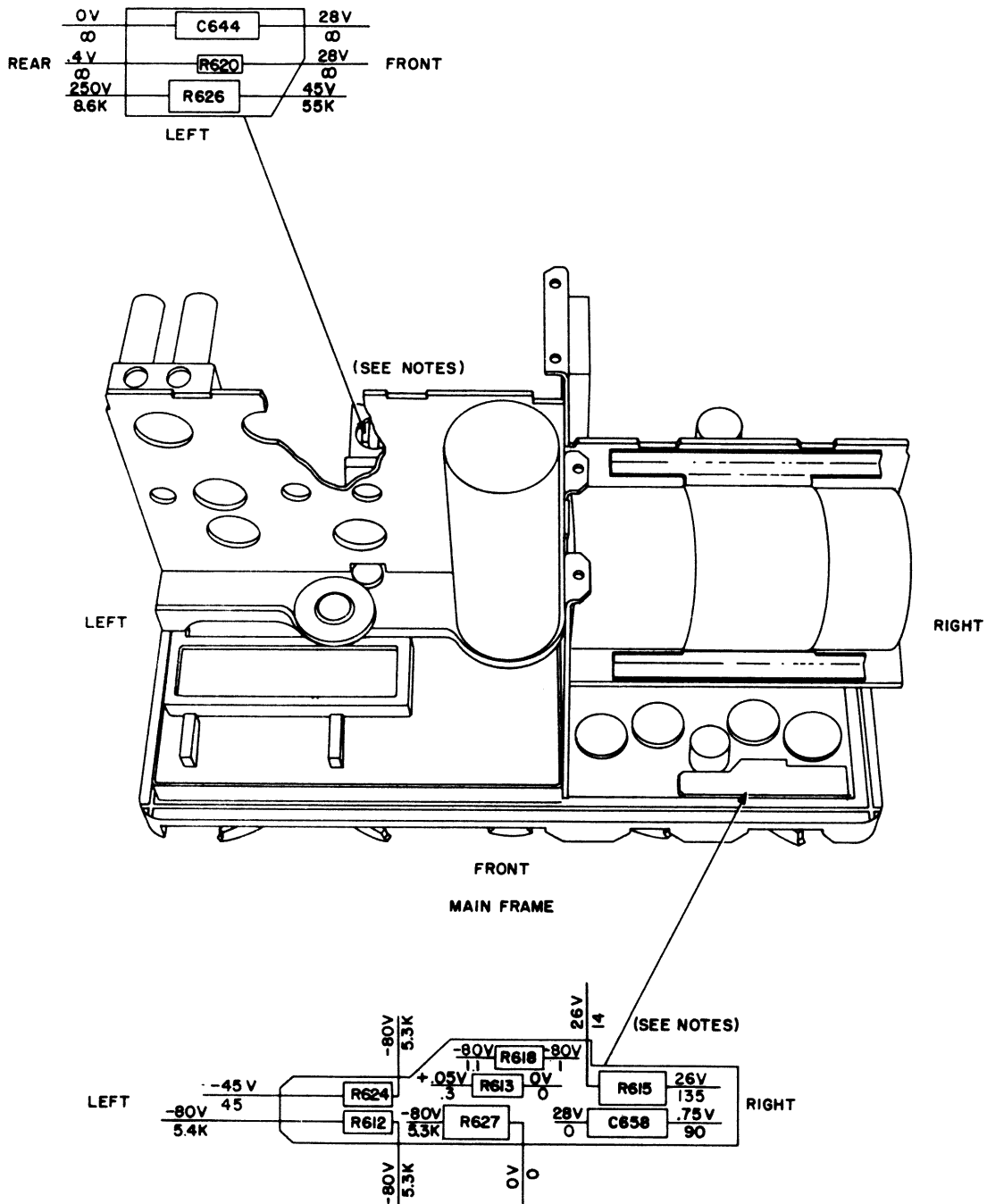

NOTES

1. UNLESS OTHERWISE SHOWN, RESISTANCE IS SHOWN IN OHMS, AND ARE MEASURED FROM BOARD TERMINAL TO GROUND WITH A 20,000 OHMS-PER-VOLT METER.
2. VOLTAGES ARE DC, AND ARE MEASURED FROM BOARD TERMINAL TO GROUND WITH A VTVM.
3. MEASUREMENTS ARE TAKEN WITH **TEST KEY** SWITCH HELD **ON**, **TEST METER** SWITCH TO **PA CATH**, **SERVICE SELECTOR** SWITCH TO **CW**, **DIAL DIM** SWITCH TO **FULL**, AND **BAND SELECTOR** AND **TUNING CONTROL** ADJUSTED TO 18 MC.

TM 806-95

Figure 2-65. Main frame, terminal board measurements.

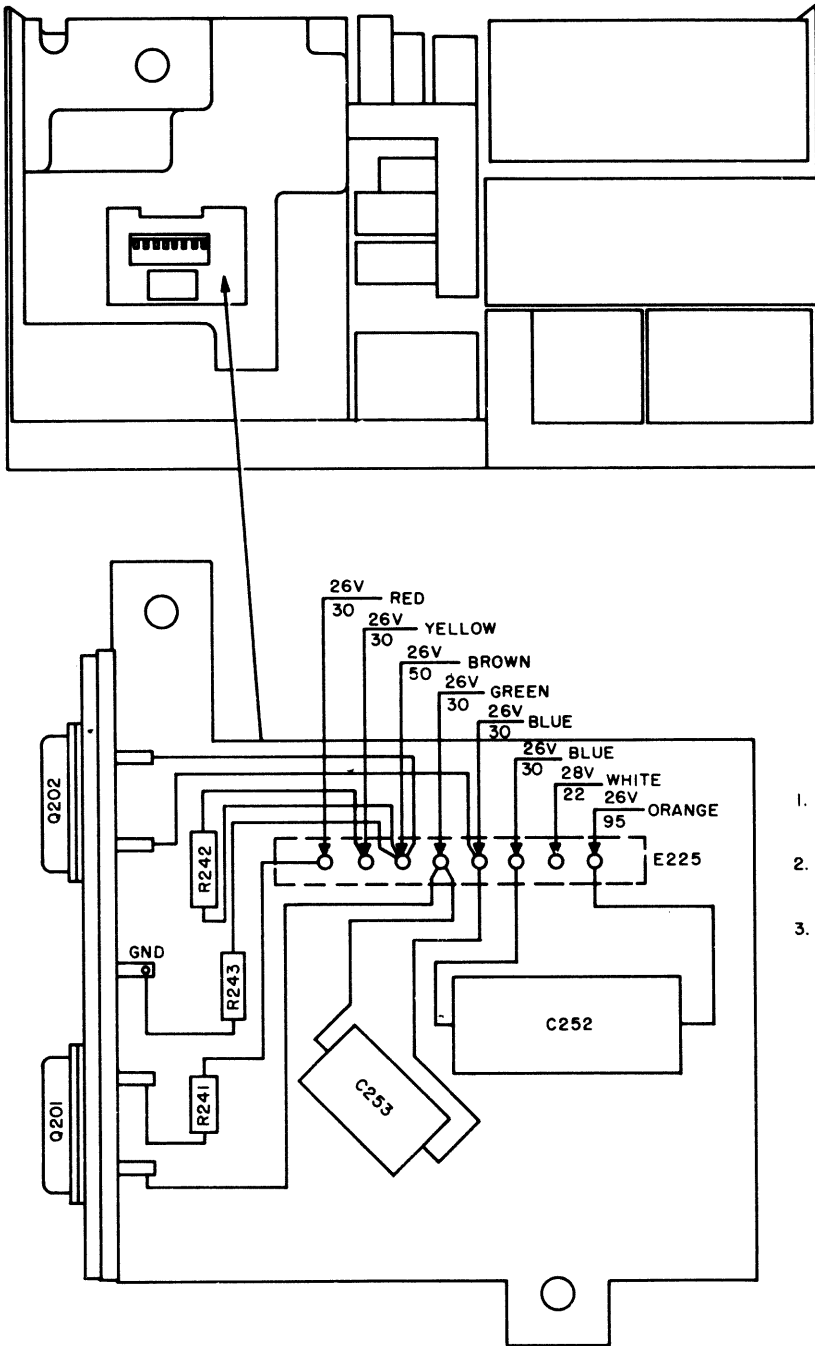

**NOTES**

1. UNLESS OTHERWISE INDICATED, RESISTANCES ARE IN OHMS AND ARE MEASURED WITH NEGATIVE LEAD OF METER CONNECTED TO GROUND
2. UNLESS OTHERWISE INDICATED, ALL VOLTAGES ARE DC AND MEASURED WITH NEGATIVE LEAD CONNECTED TO GROUND USING A 20,000 OHMS-PER-VOLT METER
3. VOLTAGE MEASUREMENTS ARE MADE WITH BLOWER OPERATING UNDER LOAD CONDITIONS

TM806-C9-13

Figure 2-66. Power amplifier subchassis, pa blower terminal board measurements.



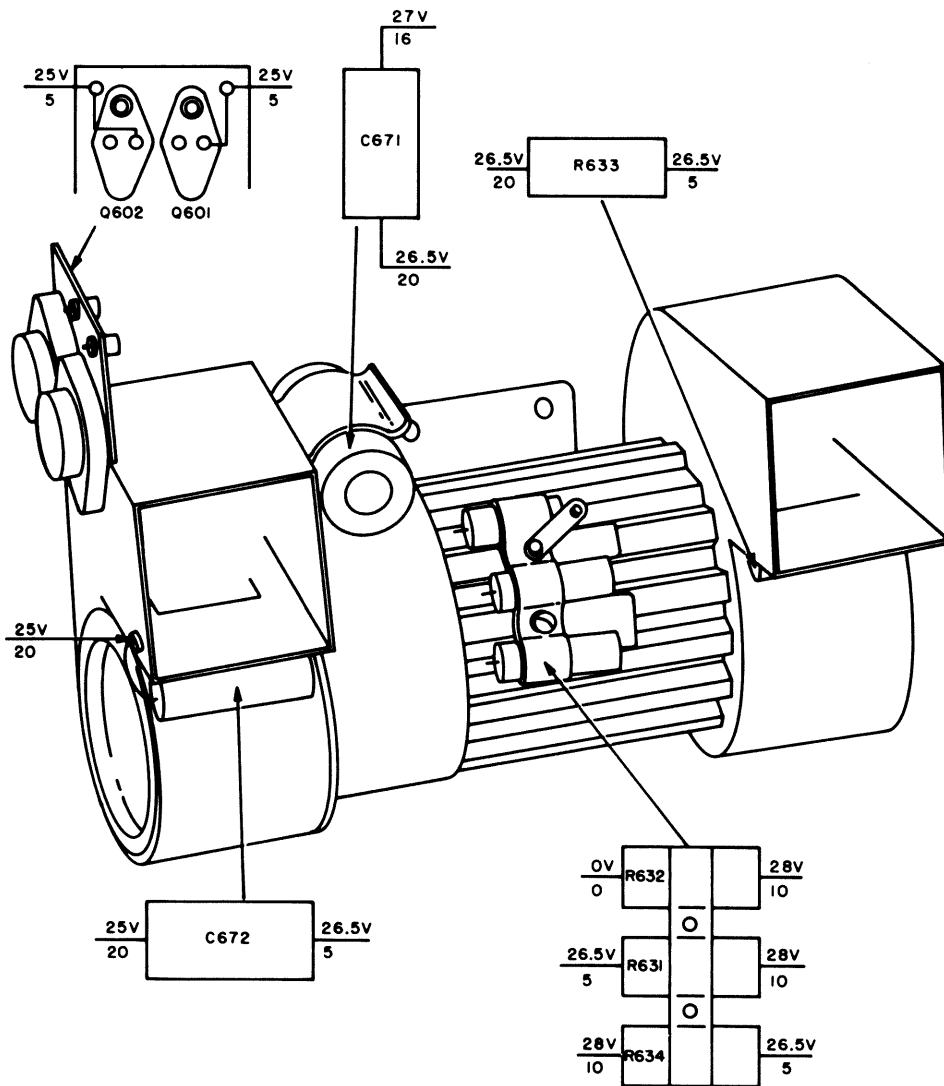

**NOTES**

1. UNLESS OTHERWISE INDICATED, RESISTANCES ARE IN OHMS AND ARE MEASURED WITH NEGATIVE LEAD OF METER CONNECTED TO GROUND
2. UNLESS OTHERWISE INDICATED, ALL VOLTAGES ARE DC AND MEASURED WITH NEGATIVE LEAD CONNECTED TO GROUND USING A 20,000 OHMS-PER-VOLT METER
3. VOLTAGE MEASUREMENTS ARE MADE WITH BLOWER OPERATING UNDER LOAD CONDITIONS

TM806-C9-14

Figure 2-67. Exhaust blower, terminal board measurements.

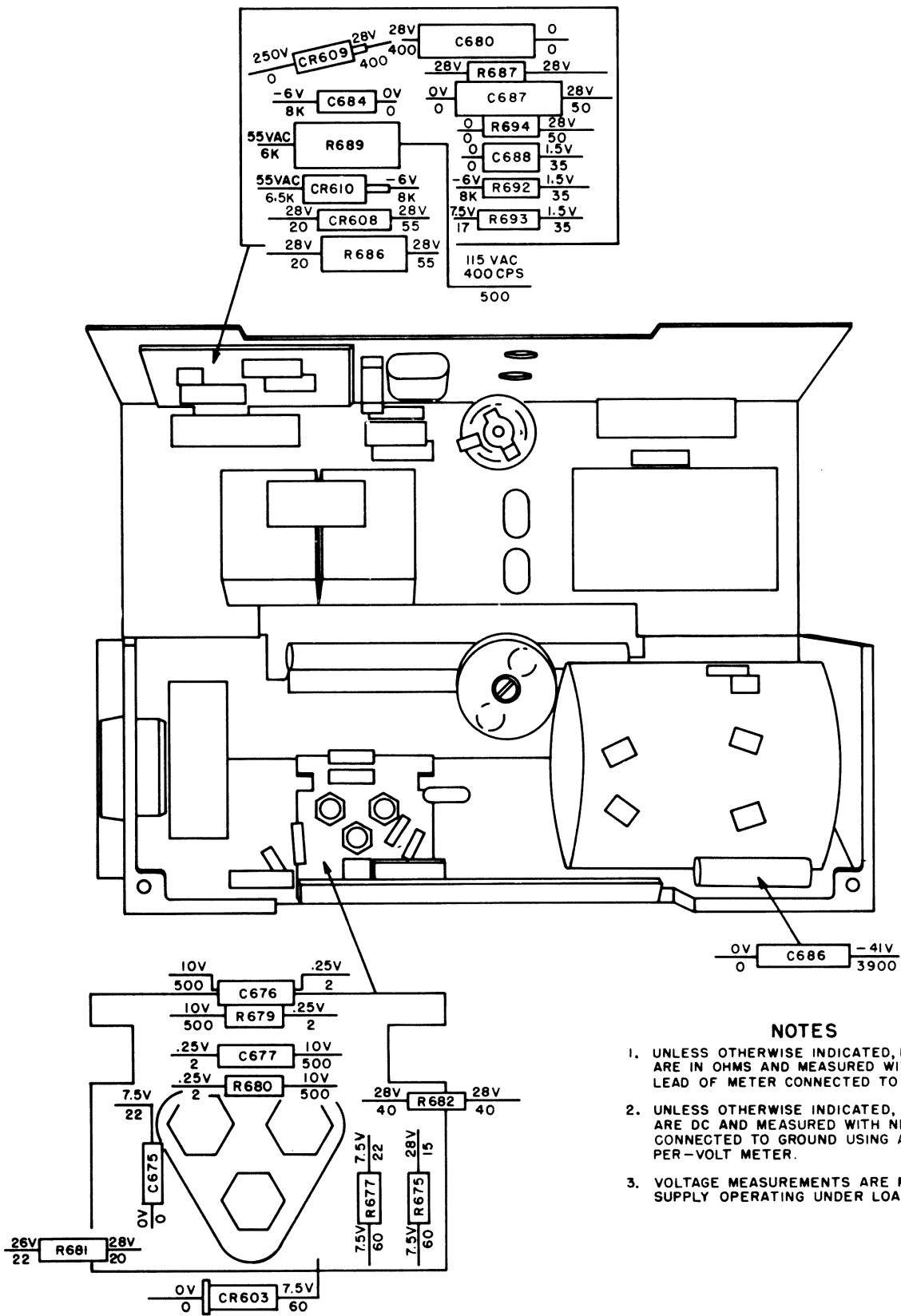

**NOTES**

1. UNLESS OTHERWISE INDICATED, RESISTANCES ARE IN OHMS AND MEASURED WITH NEGATIVE LEAD OF METER CONNECTED TO GROUND
2. UNLESS OTHERWISE INDICATED, ALL VOLTAGES ARE DC AND MEASURED WITH NEGATIVE LEAD CONNECTED TO GROUND USING A 20,000 OHMS-PER-VOLT METER.
3. VOLTAGE MEASUREMENTS ARE MADE WITH POWER SUPPLY OPERATING UNDER LOAD CONDITIONS

TM806-C9-15

Figure 2-68. Low-voltage power supply, terminal board measurements.

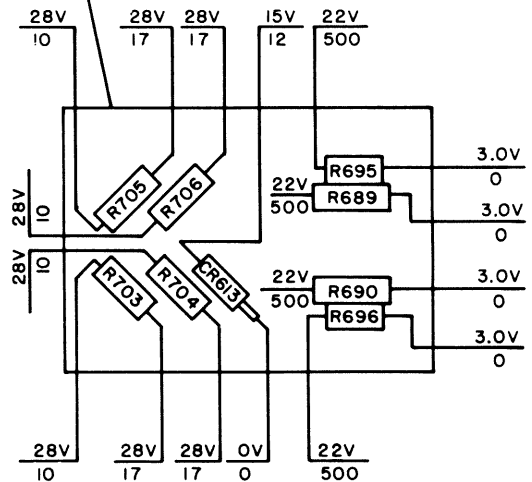
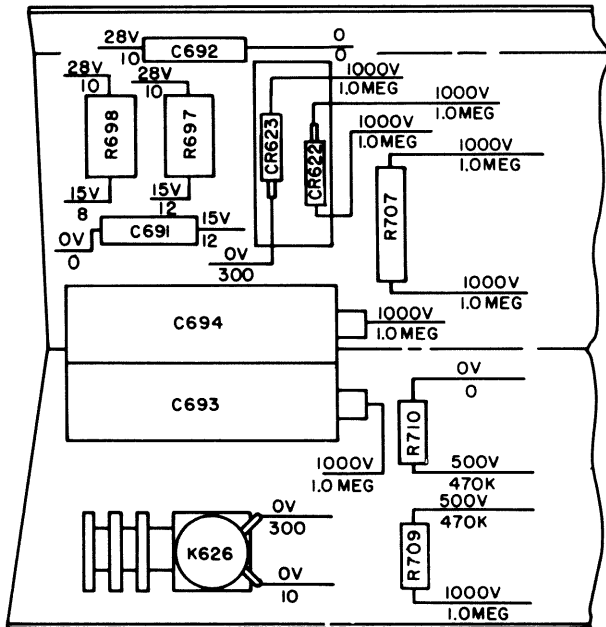
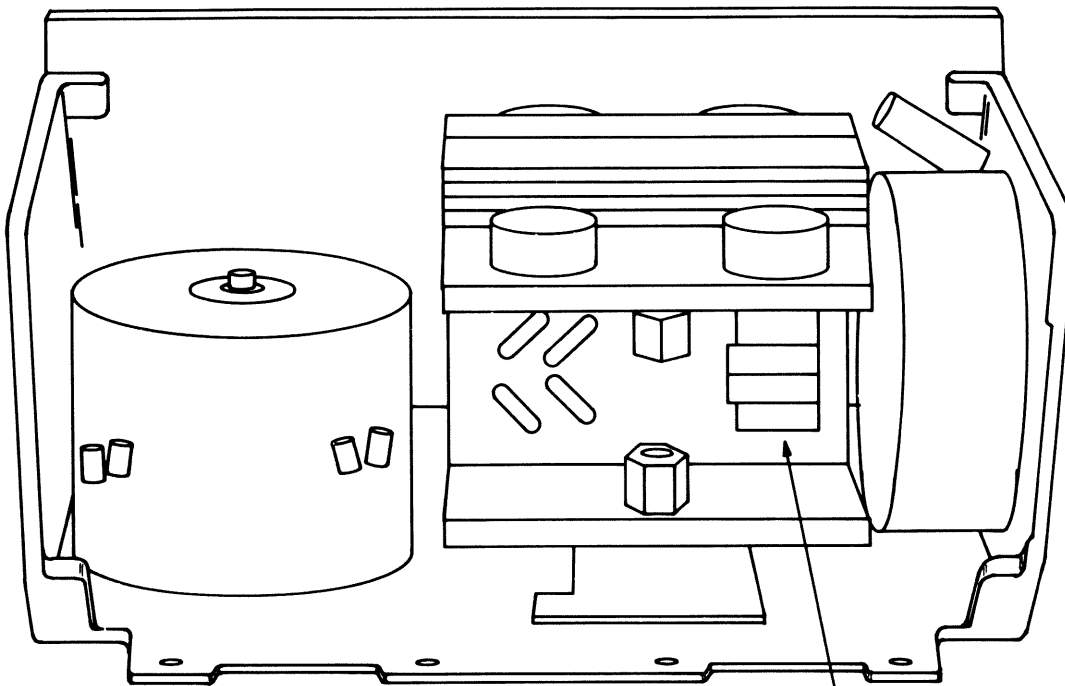

**NOTES**

1. UNLESS OTHERWISE INDICATED, RESISTANCES ARE IN OHMS AND ARE MEASURED WITH NEGATIVE LEAD OF METER CONNECTED TO GROUND
2. UNLESS OTHERWISE INDICATED, ALL VOLTAGES ARE DC AND MEASURED WITH NEGATIVE LEAD CONNECTED TO GROUND USING A 20,000 OHMS-PER-VOLT METER
3. VOLTAGE MEASUREMENTS ARE MADE WITH POWER SUPPLY OPERATING UNDER LOAD CONDITIONS

TM806-C9-16

Figure 2-69. High-voltage power supply, terminal board measurements.

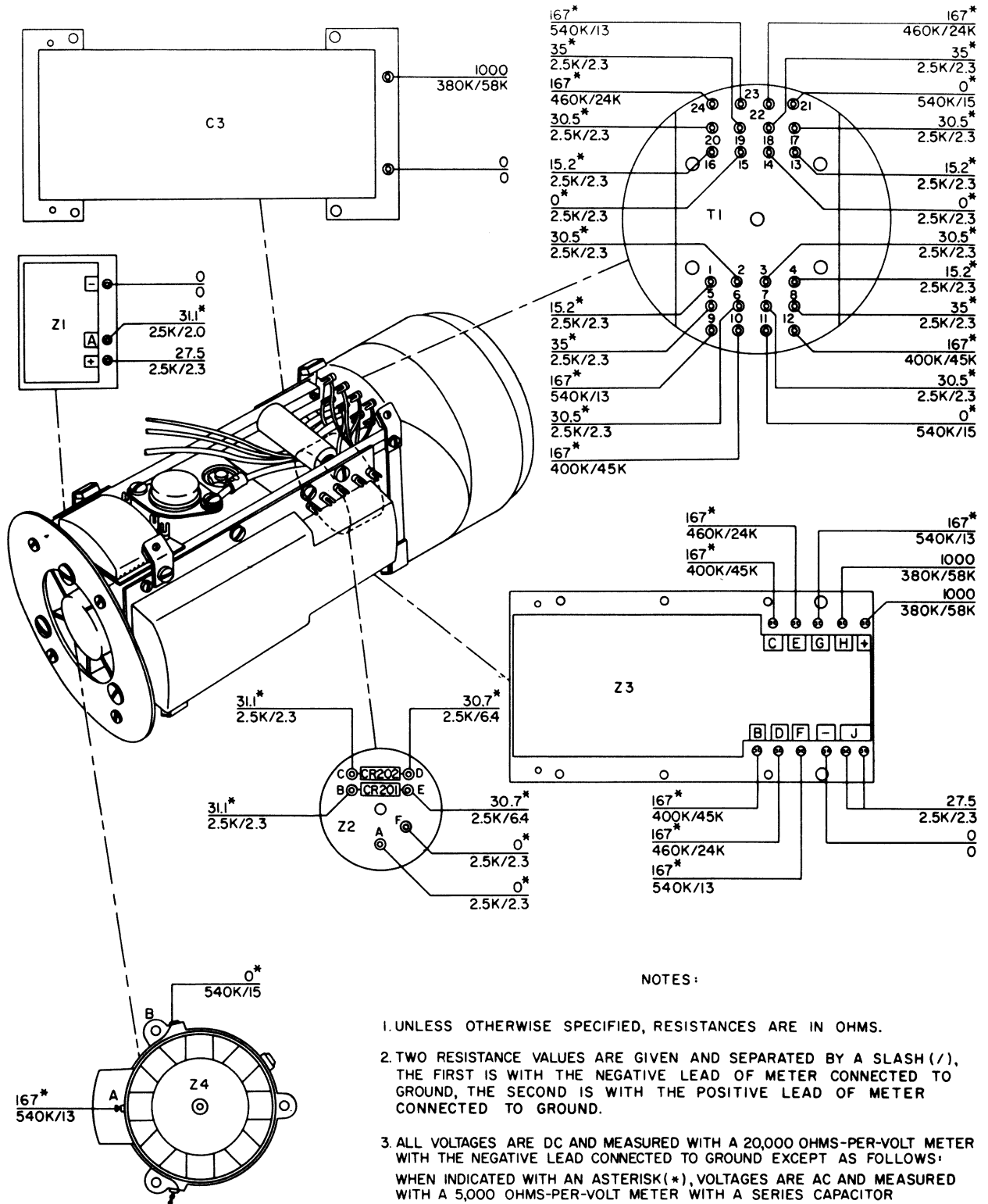

NOTES:

1. UNLESS OTHERWISE SPECIFIED, RESISTANCES ARE IN OHMS.
2. TWO RESISTANCE VALUES ARE GIVEN AND SEPARATED BY A SLASH (/), THE FIRST IS WITH THE NEGATIVE LEAD OF METER CONNECTED TO GROUND, THE SECOND IS WITH THE POSITIVE LEAD OF METER CONNECTED TO GROUND.
3. ALL VOLTAGES ARE DC AND MEASURED WITH A 20,000 OHMS-PER-VOLT METER WITH THE NEGATIVE LEAD CONNECTED TO GROUND EXCEPT AS FOLLOWS: WHEN INDICATED WITH AN ASTERISK (\*), VOLTAGES ARE AC AND MEASURED WITH A 5,000 OHMS-PER-VOLT METER WITH A SERIES CAPACITOR
4. VOLTAGE MEASUREMENTS ARE MADE WITH THE POWER SUPPLY OPERATING UNDER LOAD CONDITIONS.

TM806-C10-10

Figure 2-70. High-voltage power supply PS602, terminal board measurements.

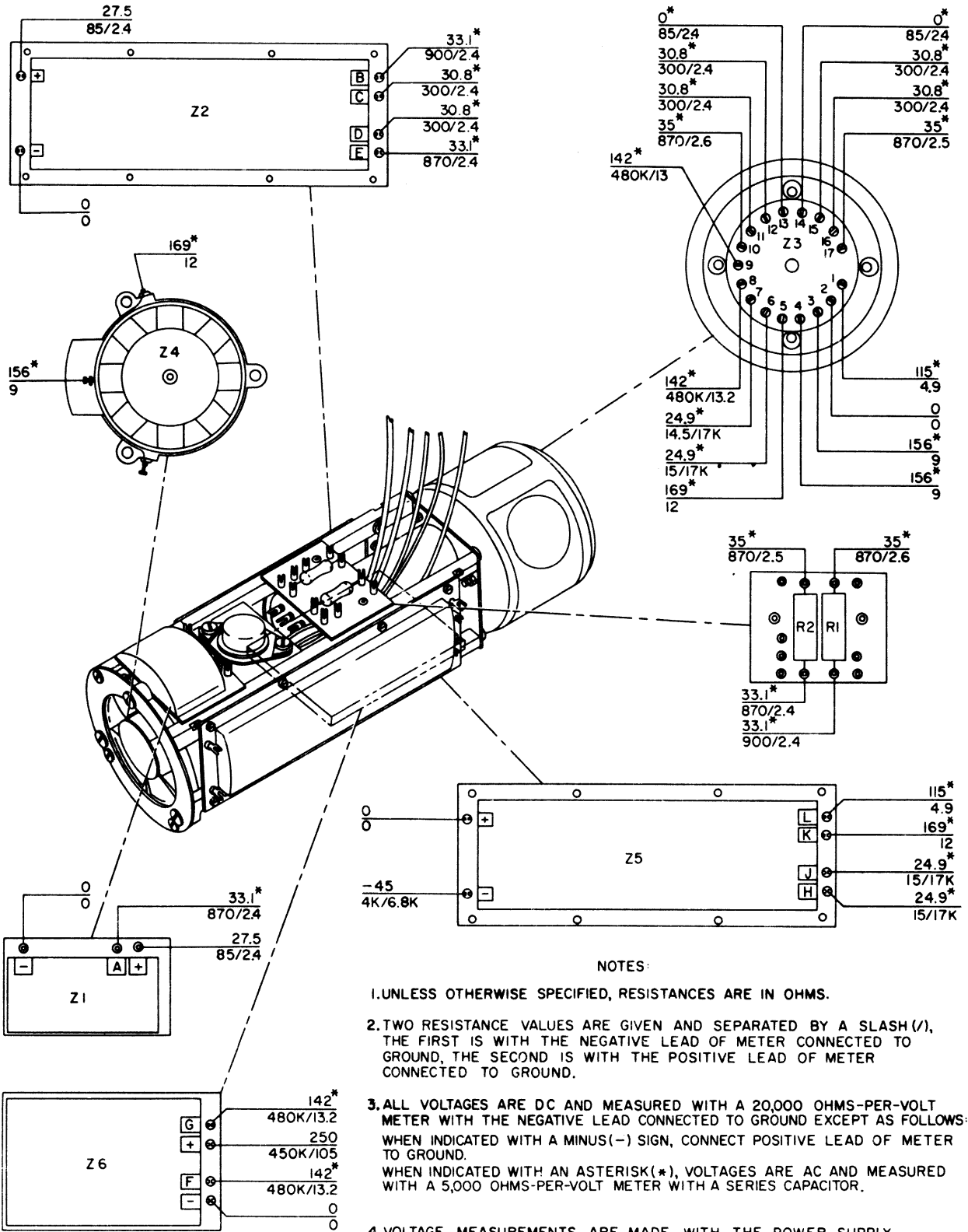

NOTES:

1. UNLESS OTHERWISE SPECIFIED, RESISTANCES ARE IN OHMS.
2. TWO RESISTANCE VALUES ARE GIVEN AND SEPARATED BY A SLASH (/), THE FIRST IS WITH THE NEGATIVE LEAD OF METER CONNECTED TO GROUND, THE SECOND IS WITH THE POSITIVE LEAD OF METER CONNECTED TO GROUND.
3. ALL VOLTAGES ARE DC AND MEASURED WITH A 20,000 OHMS-PER-VOLT METER WITH THE NEGATIVE LEAD CONNECTED TO GROUND EXCEPT AS FOLLOWS: WHEN INDICATED WITH A MINUS (-) SIGN, CONNECT POSITIVE LEAD OF METER TO GROUND. WHEN INDICATED WITH AN ASTERISK (\*), VOLTAGES ARE AC AND MEASURED WITH A 5,000 OHMS-PER-VOLT METER WITH A SERIES CAPACITOR.
4. VOLTAGE MEASUREMENTS ARE MADE WITH THE POWER SUPPLY OPERATING UNDER LOAD CONDITIONS.

TM806-C10-11

Figure 2-71. Low-voltage power supply PS601, terminal board measurements.

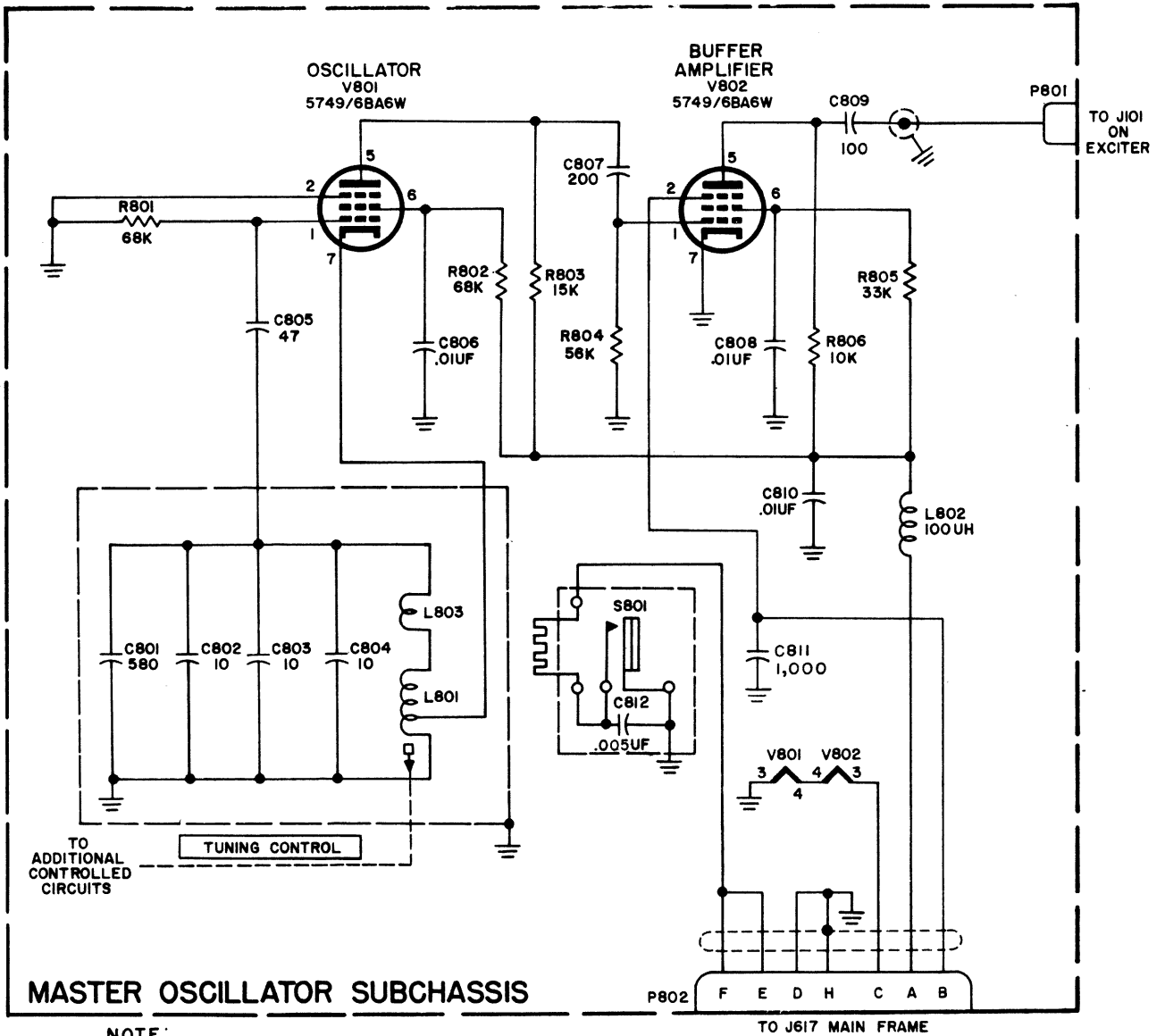

TM5820-335-35-32

Figure 2-72. Master oscillator subchassis, schematic diagram.

# DISCRIMINATOR

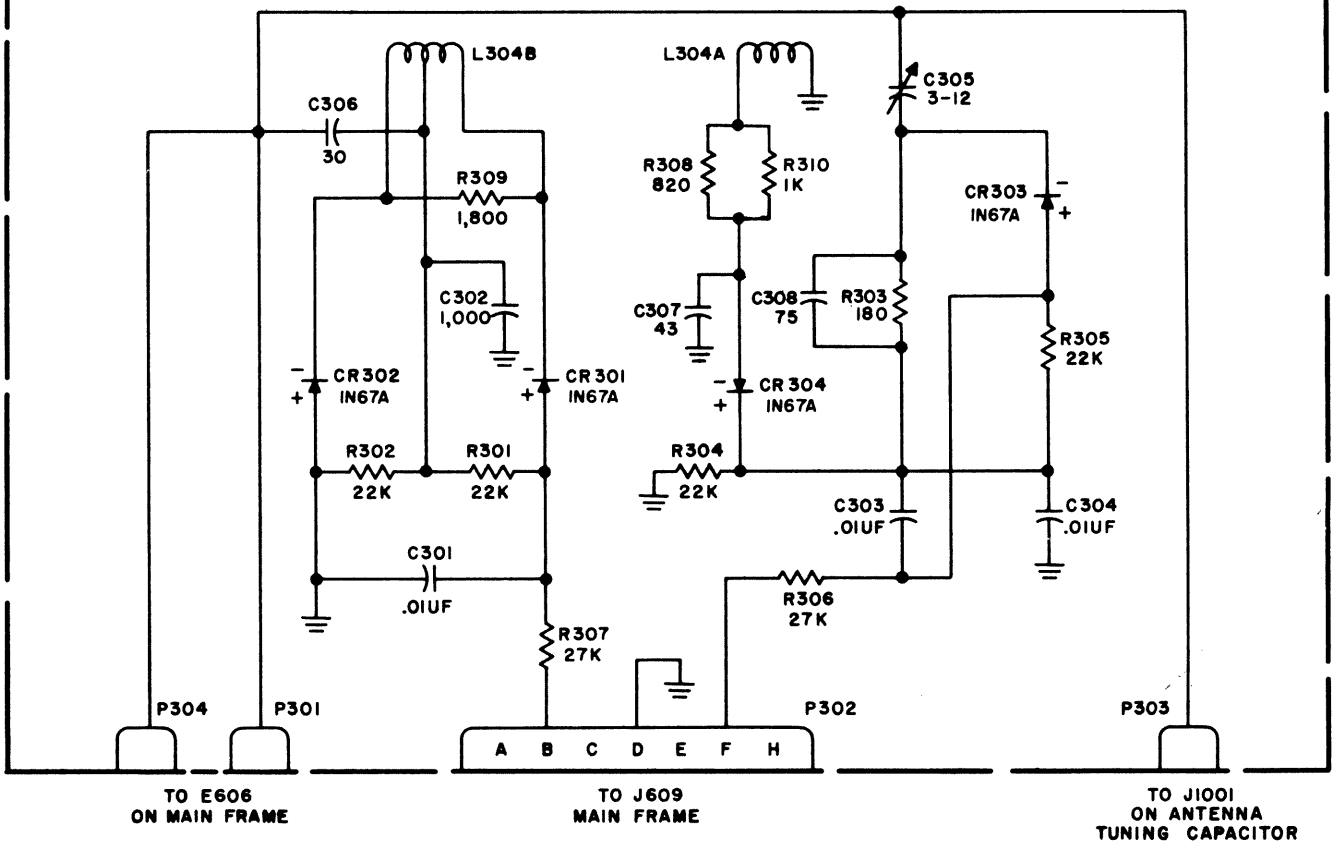

TM806-129

Figure 2-76. Discriminator subchassis, schematic diagram.

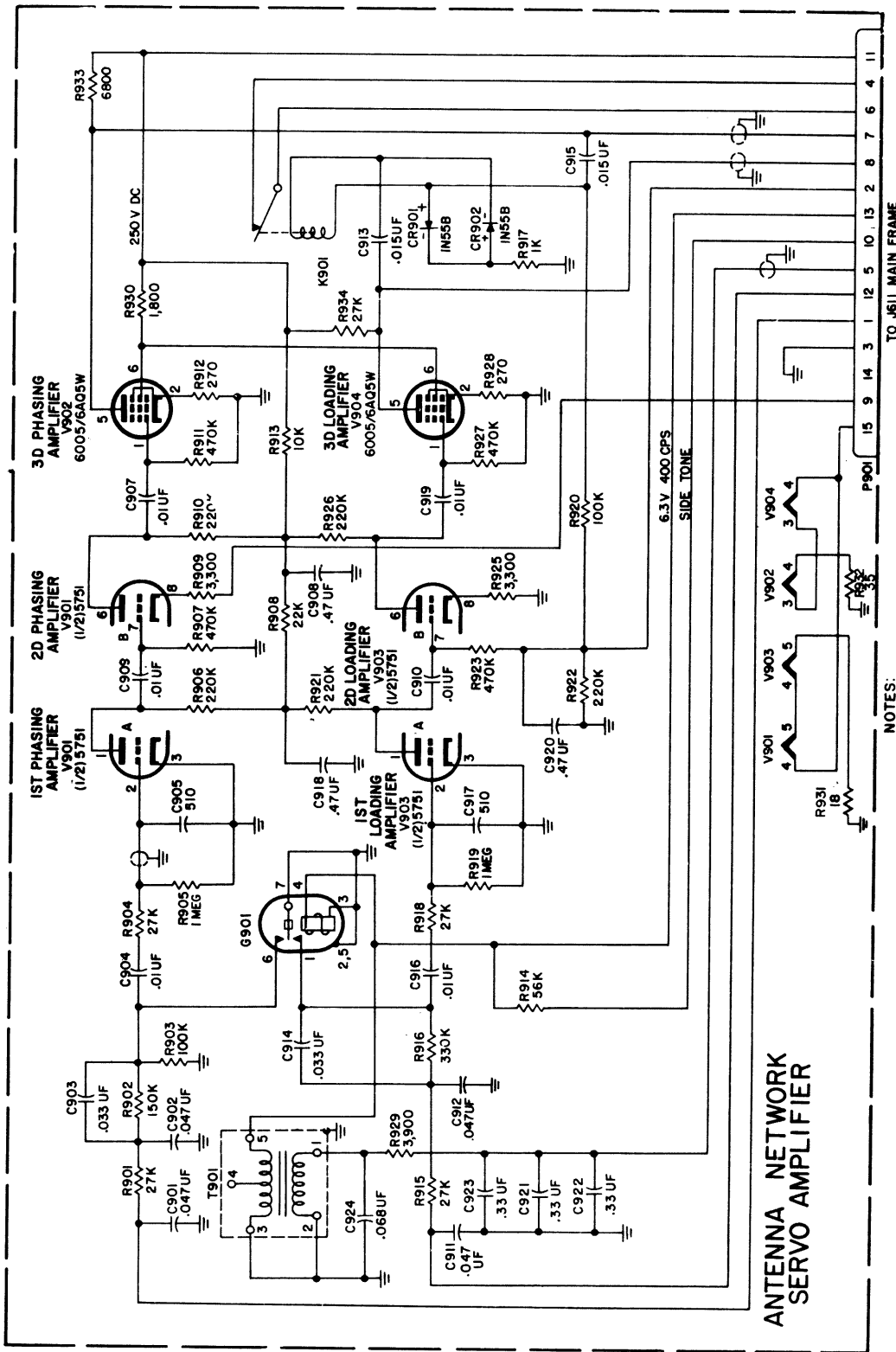

ANTENNA NETWORK  
SERVO AMPLIFIER

TO J611 MAIN FRAME

NOTES:

1. UNLESS OTHERWISE SHOWN, RESISTORS ARE IN OHMS, AND HIGHER, CHANGE THE VALUE
2. FOR MODELS OF SERVO AMPLIFIER OF R916 FROM 330 K TO 560K

TM5820-335-35-34

Figure 2-77. Antenna network servo amplifier schematic diagram.



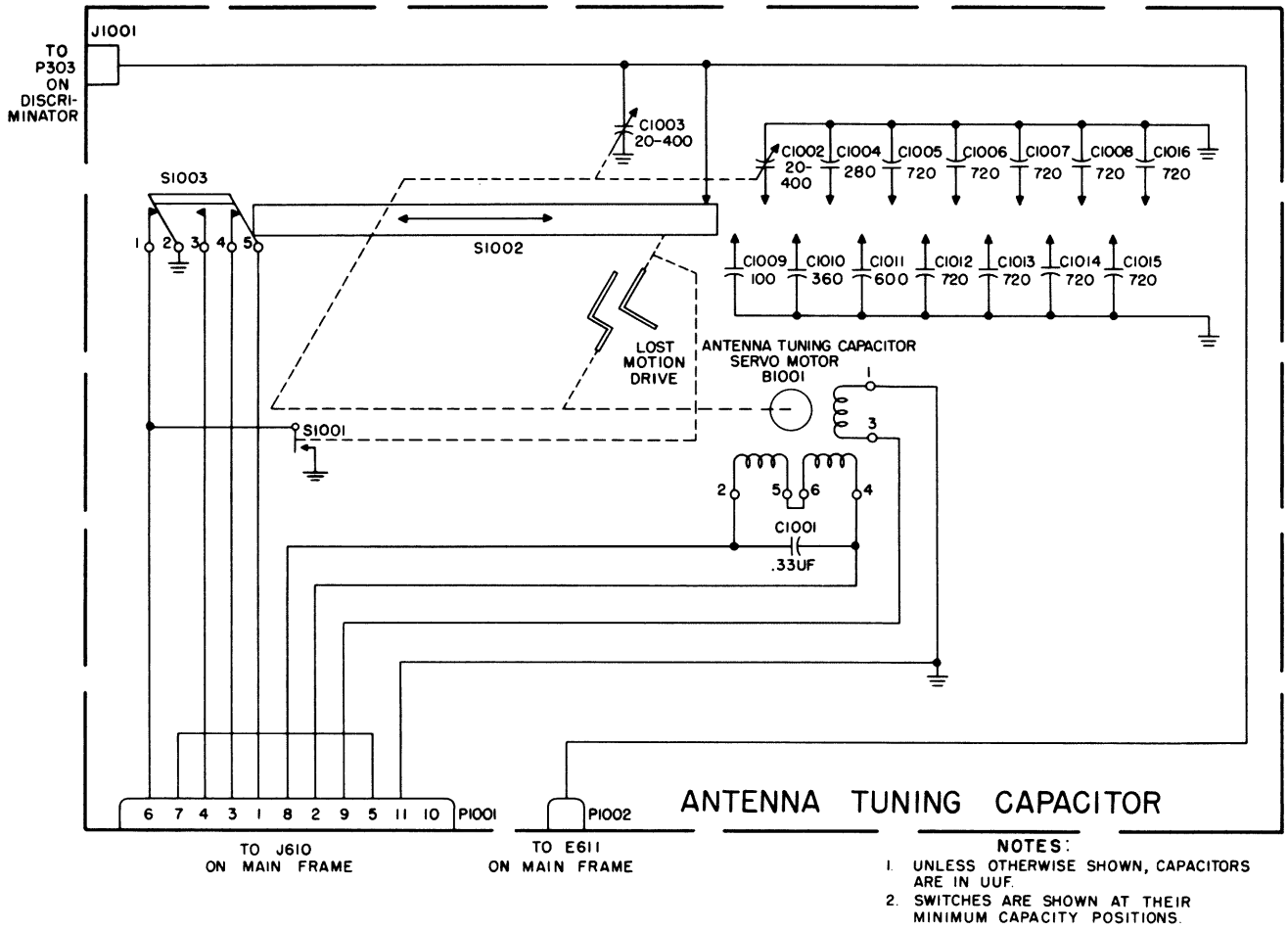

TM806-134

Figure 2-78. Antenna tuning capacitor subchassis, schematic diagram.

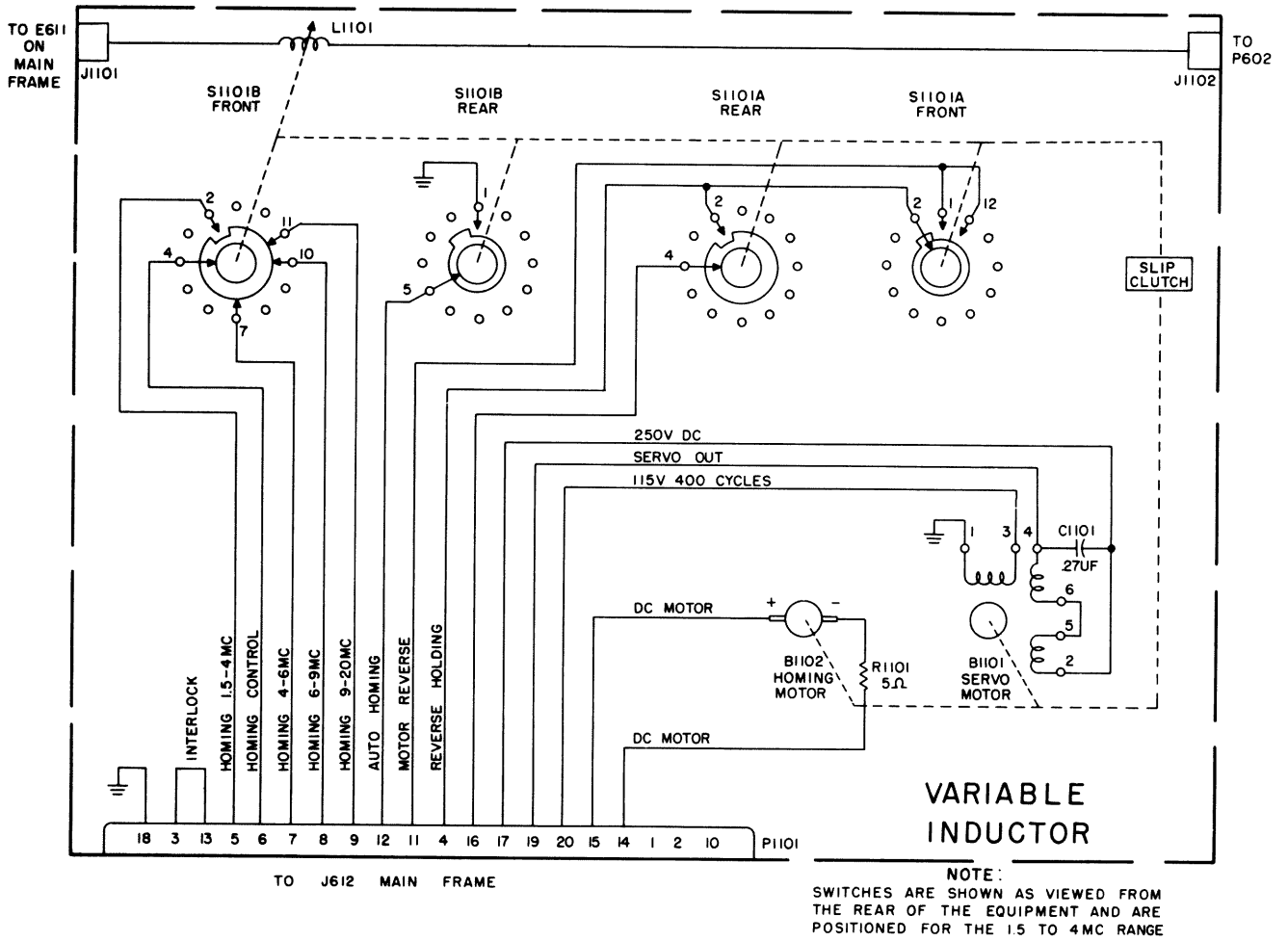

TM806-135

Figure 2-79. Variable inductor subchassis, schematic diagram.

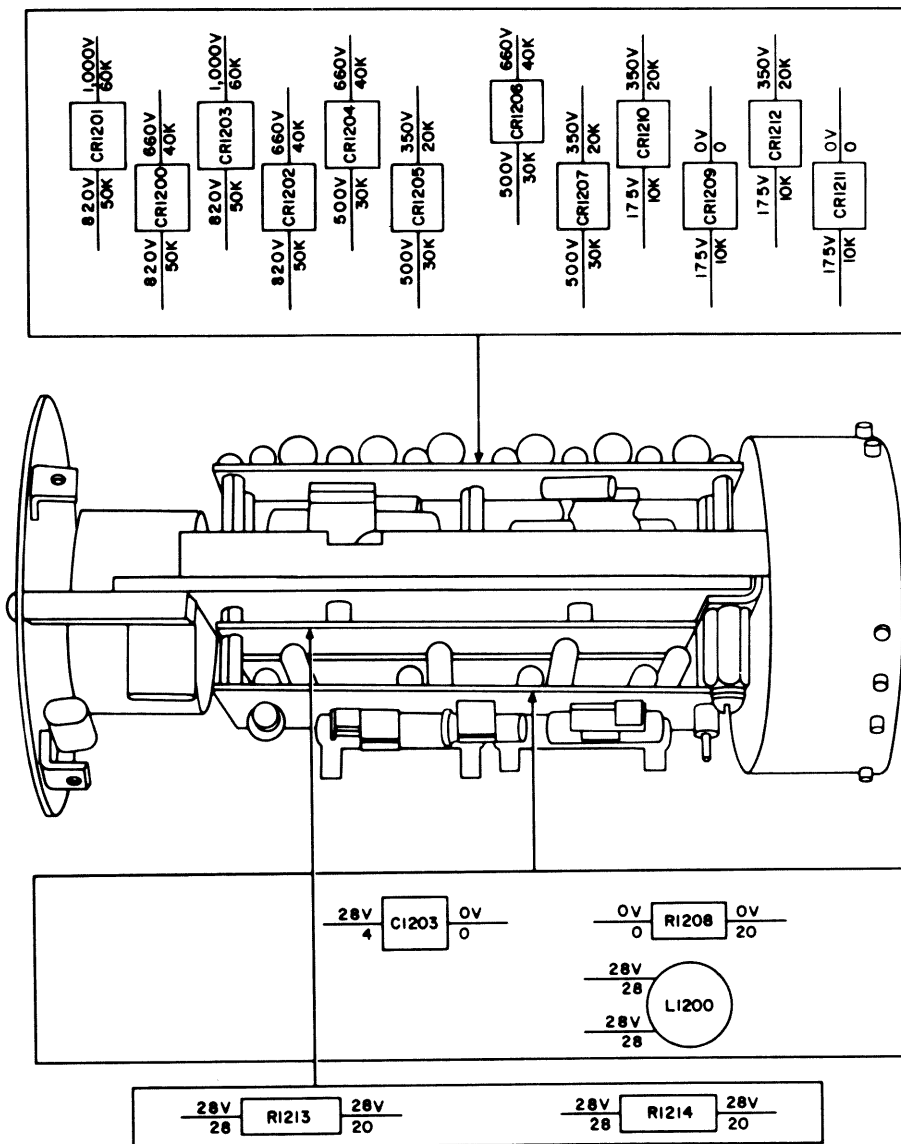

- NOTES:
1. UNLESS OTHERWISE SHOWN, RESISTANCES ARE IN OHMS AND ARE MEASURED WITH NEGATIVE LEAD OF METER CONNECTED TO GROUND.
  2. ALL VOLTAGES ARE DC AND MEASURED WITH NEGATIVE LEAD CONNECTED TO GROUND USING A 20,000 OHMS-PER-VOLT METER.
  3. VOLTAGE MEASUREMENTS ARE MADE WITH POWER SUPPLY OPERATING UNDER LOAD CONDITIONS.

TM806-C6-5

Figure 2-83. High-voltage power supply A1200 (MOD1) voltage and resistance diagram.

## Section IV. ADDITIONAL TROUBLESHOOTING DATA

### 2-10. Dc Resistances of Transformers, Coils, and Motors

The dc resistances of the subchassis and main frame are measured with each subchassis re-

moved from the main frame. The dc resistances of the transformer windings, coils, and motors as measured with a 20,000 ohms-per-volt meter are listed below:

Item	Terminals	Ohms
L111	J101-J102	1.7.
L112		.20.
Z101		Less than 1.0.
Z102		Less than 1.0.
Z103		Less than 1.0.
Z104		Less than 1.0.
Z105		Less than 1.0.
Z106		Less than 1.0.
Z107		Less than 1.0.
Z108		Less than 1.0.
Z109		Less than 1.0.
Z110		Less than 1.0.
B201	1-3	125.
	2-4	125.
B202		.14.
K201		.700.
K202		4.5.
K203		250.
L201		19.
L202		2.
L203		1.6.
L204 <sup>a</sup>		Less than 1.0.
L205		19
L206		Less than 1.0.
L207		1.3.
S202		12.
L304A	Loading discriminator coil.	Less than 1.0.
L304B	Phasing discriminator coil.	Less than 1.0.
K402	1-6	250.
Z401	Input	72.
Z401	Output	10K.
Z402	Input	Infinite.
Z402	Output	Infinite.
T401	1-2	850.
T401	3-4	65.
B601	Armature	2.
	Field	18.
B602		1.5.
B603		15.
D601	+124 volt	4.
	+250 volt	7.
	-45 volt	2,500.
	115 volt, ac	16.
D602	+24 volt	Less than 1.
	+1,000 volt	180.
K601		8,000.
K602	2-1	108.
K603		110.
K604		200.
K605		25.
K608		280.
K609		200.
K610		100.
K613		200.
K614		40.
K615		350.
K616		200.
K617		200.
L601		Less than 1.
L622		Less than 1.

Item	Terminals	Ohms
L603		20.
	through L608.	
L611		20.
	through L613.	
L617 through L621		20.
L623		30.
M602		Less than 1.
M603		3,900.
S608		0.
S610		150.
RT601		13.
S802		2.5
S801		14.
G901 <sup>b</sup>	3-4	300.
K901 <sup>c</sup>	Across relay coil	800.
	Across relay coil	7,500.
T901	1-2	480.
	3-5	2.
B1001 and B1101.	2-5	75.
	4-6	75.
	2-4	150.
	1-3	150.
B1102		7.5.
K608	1-2/4-7 <sup>e</sup>	280/200 <sup>d</sup>
K610	1-2/1-10 <sup>e</sup>	100/200 <sup>d</sup>
T1200 <sup>f</sup>	1-3	0.
T1200 <sup>f</sup>	4-6	Less than 1.
T1200 <sup>f</sup>	7-8	3.
T1200 <sup>f</sup>	9-10	3.
T1200 <sup>f</sup>	11-12	3.
K1200 <sup>f</sup>	4-8	500
B1200 <sup>f</sup>	T <sub>1</sub> -T <sub>5</sub>	90.
B1200 <sup>f</sup>	T <sub>1</sub> -T <sub>4</sub>	0.
B1200 <sup>f</sup>	T <sub>1</sub> -T <sub>8</sub>	90.

<sup>a</sup> Resistance too low for reading.

<sup>b</sup> Reading taken with G901 removed from socket XG901. In the T-195A/GRC-19, G901 is transistorized and does not have a coil.

<sup>c</sup> Two readings taken when reversing the ohmmeter leads. For convenience, connect the leads to the plate of CR901 and the cathode of CR902 (fig. 1-46).

<sup>d</sup> Resistance values preceding slash marks are for open-type relays; values following slash marks are for hermetically sealed type.

<sup>e</sup> Terminal numbers preceding slash marks are for open type relays; numbers following slash marks are for hermetically sealed type.

<sup>f</sup> Applicable only to high-voltage power supply A1200, used in T-195A/GRC-19.

## 2-11. Resistance Measurements of Receptacles and Connectors

### NOTE

Readings were taken under the following conditions:

1. Readings taken with 20,000-ohm voltmeter.
2. All readings from indicated point to ground.
3. Transmitter on band No. 1.
4. Frequency at 1.5 mc.
5. LINE LEVEL control completely clockwise.

6. SERVICE SELECTOR in OFF position.
7. DIAL DIM switch in FULL position.
8. RELAY-NORMAL-DUPLEX switch in NORMAL position.
9. TEST METER IN PA CATH position.
10. No external connections to equipment.
11. Variable inductor at maximum inductance.
12. Connector under test electrical-ly disconnected.

Connector	Pin or socket No.	Resistance (ohms)
J606	1	Infinite.
	2	Infinite.
	3	Infinite.
	4	20,000.
	5	38.
	6	Infinite.
	7	50 K.
	8	Infinite.
	9	50 K.
	10	Infinite.
	11	90.
	12	Infinite.
	13	150 K.
	14	300.
	15	Infinite.
	16	Infinite.
	17	0.
	18	2.5.
	19	Infinite.
	20	25.
P401	1	45.
	2	Infinite.
	3	Infinite.
	4	75.
	5	Infinite.
	6	2,100.
	7	Infinite.
	8	Infinite.
	9	Infinite.
	10	500.
	11	Infinite.
	12	60.
	13	Infinite.
	14	280.
	15	Infinite.
	16	Infinite.
	17	0.
	18	200.
	19	Infinite.
	20	3.
J607	1	200.
	2	200.
	3	200.
	4	200.
	5	Infinite.

Connector	Pin or socket No.	Resistance (ohms)	
P101	6	40.	
	7	Infinite.	
	8	Infinite.	
	9	Infinite.	
	10	Infinite.	
	11	Less than 1.	
	12	Infinite.	
	13	90.	
	14	Infinite.	
	15	0.	
	J609	1	0.
		2	Infinite.
		3	0.
		4	Infinite.
		5	Infinite.
6		Infinite.	
7		0.	
8		Infinite.	
9		Infinite.	
10		Infinite.	
11		55.	
12		0.	
13		370 K.	
14		60.	
15		0.	
P302	A	Infinite.	
	B	600 K.	
	C	Infinite.	
	D	0.	
	E	Infinite.	
	F	600 K.	
	H	Infinite.	
	J608	A	Infinite.
B		60 K.	
C		Infinite.	
D		0.	
E		Infinite.	
F		60 K.	
H		Infinite.	
P201		1	240.
	2	2.	
	3	Infinite.	
	4	200.	
	5	Less than 1.	
	6	0.	
	7	Infinite.	
	8	250.	
	9	90.	
	10	5,200.	
	11	2.	
	12	14.	
	13	5.	
	14	Infinite.	
	15	0.	
J607	1	300.	
	2	5.	
	3	270 K.	
	4	Infinite.	
	5	Infinite.	
	6	500.	
	7	900 K.	
	8	2.	
	9	1.1 meg.	
	10	360 K.	
	11	160.	

Connector	Pin or socket No.	Resistance (ohms)	
J611	12	160.	
	13	5.	
	14	Less than 1.	
	15	0.	
	1	500 K.	
	2	0.	
	3	0.	
	4	28.	
	5	12.	
	6	39.	
	7	250.	
	8	270.	
	9	45.	
	10	Infinite.	
	11	90.	
P901	12	90 K.	
	13	Infinite.	
	14	4.	
	15	4.	
	1	180 K.	
	2	75 K.	
	3	0.	
	4	Infinite.	
	5	4.4 K.	
	6	Infinite.	
	7	Infinite.	
	8	Infinite.	
	9	Infinite.	
	10	60 K.	
	11	Infinite.	
J610	12	Infinite.	
	13	2.0.	
	14	Infinite.	
	15	20.	
	1	Infinite.	
	2	7,000.	
	3	200.	
	4	Infinite.	
	5	Infinite.	
	6	100 K.	
	7	0.	
	8	90.	
	9	13.	
	10	Infinite.	
	11	0.	
P1001	1	Infinite.	
	2	Infinite.	
	3	Infinite.	
	4	Infinite.	
	5	Infinite.	
	6	0.	
	7	Infinite.	
	8	Infinite.	
	9	170.	
	10	Infinite.	
	11	0.	
	J612	1	Infinite.
		2	Infinite.
		3	Infinite.
		4	Infinite.
5		0.	
6		Infinite.	
7		Infinite.	
8		Infinite.	

Connector	Pin or socket No.	Resistance (ohms)	
J612	9	Infinite.	
	10	Infinite.	
	11	Infinite.	
	12	180.	
	13	Infinite.	
	14	Infinite.	
	15	Infinite.	
	16	Infinite.	
	17	90.	
	18	0.	
	19	Infinite.	
	20	14.	
	P1101	1	Infinite.
		2	Infinite.
		3	Infinite.
		4	Infinite.
		5	Infinite.
		6	Infinite.
		7	Infinite.
		8	Infinite.
9		Infinite.	
10		Infinite.	
11		Infinite.	
12		Infinite.	
13		Infinite.	
14		Infinite.	
15		Infinite.	
16		Infinite.	
17		Infinite.	
18		Infinite.	
19		Infinite.	
20		Infinite.	
J617	A	3,000.	
	B	Infinite.	
	C	60.	
	D	0.	
	E	5.	
	F	0.	
	H	Infinite.	
	P802	A	Infinite.
B		Infinite.	
C		6.	
D		0.	
E		Infinite.	
F		Infinite.	
H		0.	
REMOTE CONT		A	Infinite.
	B	57.	
	C	Infinite.	
	D	Infinite.	
	E	Infinite.	
	F	Infinite.	
	H	Infinite.	
	J	430.	
	K	14.	
	L	Infinite.	
	M	Infinite.	
	N	Infinite.	
	P	Infinite.	
	R	0.	
	J601	S	Infinite.
		T	Infinite.
U		Infinite.	
V		Infinite.	
W		Infinite.	

Connector	Pin or socket No.	Resistance (ohms)	
AUDIO J603	A	57.	
	B	0.	
	C	430.	
	D	Infinite.	
	E	0.	
	F	Infinite.	
	H	0.	
	J	Infinite.	
	K	Infinite.	
	L	Infinite.	
	RECEIVER CONT J604	A	Infinite.
		B	Infinite.
C		430.	

Connector	Pin or socket No.	Resistance (ohms)
24 VOLTS DC J605	D	Infinite.
	E	0.
	F	Infinite.
	H	57.
	J	Infinite.
	K	Infinite.
	A	Infinite.
	B	Infinite.
	C	0.
	D	0.
	WHIP ANTENNA J615	
RECEIVER ANTENNA J616.		Infinite.





## CHAPTER 3

### REPAIRS AND ALINEMENT

#### Section I. REPAIRS

#### 3-1. Removals and Replacements

In *a* through *y* below directions for removing and replacing the subchassis and various detail parts of the transmitter for benchtesting or repair. Avoid changing the positions of the tuning, switching, or potentiometer shafts while any of the subchassis which have such controls are removed from the main frame. Disturbance of any of the controls indicated in the following procedures may necessitate synchronization or realignment. Subchassis mounting screws are color-coded with green heads. In most cases, these are captive screws, and need be loosened only until they are free of the main frame. When replacing the subchassis, the captive screws should first be started one at a time, in order to locate the subchassis before tightening the screws all the way. To remove a coaxial plug, press the plug in slightly and twist counterclockwise to release it; then pull the plug straight out. If coaxial plugs are not accessible, use scissor-type Tube Puller TL-201, supplied with Tool Equipment TE-113, to remove the plugs. To remove plug P302 of the antenna-network discriminator subchassis or plug P802 of the master-oscillator subchassis, twist the metal shell slightly counterclockwise to release the clamp, and then pull the plug. When replacing multicontact plugs, be sure that the pins are properly alined with the receptacle contacts, because the pins are easily bent. When loosening the clamp screws on the plugs attached to the front panel, be careful not to overdraw the screws and let the nuts drop off. Do not tighten clamp screws too far, because the threads will be stripped. When using the Bristo wrench, be sure that it is fully inserted into the screw to avoid stripping of the slots in the head.

*a. Removal of Front Panel.* To gain access to the wiring and parts on the back of the front panel (fig. 2-55), remove the front panel as follows:

(1) If the transmitter is installed on a mounting, loosen the three front clamping devices and slide the transmitter forward to remove it.

(2) Remove the transmitter from its case by loosening the 16 Allen head screws and pulling the transmitter forward by the 2 handles on the front panel.

(3) Place wooden blocks under the transmitter so that the front panel is several inches clear of the work bench surface.

(4) Remove the locking keys, the indicating plates, and the spring washers from the BAND SELECTOR and TUNING CONTROL knobs by turning the locking bars in a counterclockwise direction. Rotate these control knobs fully counterclockwise (to home stop position); then rotate them clockwise until the knob setscrews are accessible. Make a note of the position of these knobs as shown on the frequency indicator; then remove them by loosening setscrews with a No. 8 fluted wrench. Remove the nut and flat washer from the shaft of each control.

(5) Remove the knob from the DIAL ZERO control by removing the Phillips screw and lockwasher. Remove the nut and flat washer from the shaft of this control.

(6) Hold the metal strip to prevent its turning and remove the Phillips screw from the clip on top of antenna relay K614 (fig. 2-56). This releases the relay from WHIP ANTENNA receptacle 615.

#### CAUTION

Use paraffin on the screwdriver tip or use longnosed pliers to lift out washer and screw; this prevents dropping parts into the transmitter. Avoid undue strain on glass parts of relay K614. Failure to disconnect K614 from the whip antenna receptacle will cause the glass

tube of K614 to be broken when the front panel is removed.

(7) Disconnect plugs P201, P205, and P206 (fig. 2-11) of the power-amplifier subchassis from J608 and J618 (fig. 2-53). Disconnect plugs P402 and P403 (fig. 2-21) of the modulator subchassis from J619 (fig. 2-56). Disconnect plug P901 (fig. 2-28) of the antenna-network servo amplifier from J611.

(8) Remove the seven flathead screws (nearest the front panel) on each side plate that connect the side plates to the front panel casting.

(9) Use a No. 10 (5/16-inch) socket wrench and remove the nine bolts, the nine lockwashers, and the flat washers that join the front panel with the framework of the transmitter.

(10) Run a wire or cord through the uppermost bolt hole in the center of the front panel and loop it through the corresponding hole in the framework. Tie it in a loop several inches long.

(11) Carefully pull the front panel straight forward until the Autotune shafts are clear; then allow it to tilt forward about 30°. Adjust the loop of wire or cord to a length which permits it to support the forward pull of the front panel.

### CAUTION

Do not permit the internal wiring to support the weight of the front panel.

(12) Remove the rubber O-rings located inside the bushings for the BAND SELECTOR, TUNING CONTROL, and DIAL ZERO shafts. Grease the O-ring retaining groove in the bushing with Dow Corning 33 Heavy grease. Insert a new O-ring into the bushing.

(13) When any of the bolts penetrating the front panel are removed, grease the rubber O-ring with Dow Corning 33 Heavy grease before replacing, remove the defective O-ring from the bolt. Replace the split lockwasher, flat washer and new O-ring in that order. Grease the new O-ring with Dow Corning 33 Heavy grease before replacing the bolt in the front panel.

*b. Replacement of Front Panel.* To replace the front panel, proceed in the reverse order of removal. When lifting the front panel back into place after removing its temporary wire loop supports, make sure that no wires have slipped between the mating surfaces of the front panel and the framework of the transmitter. When replacing the BAND SELECTOR or TUNING CON-

TROL knobs, make sure that the setscrews within the knob are adjacent to the flatted portions of the shafts.

*c. Removal of Master-Oscillator Subchassis.* To remove the master-oscillator subchassis proceed as follows:

(1) Remove the transmitter from its case.

(2) Remove the back plate of the transmitter by removing the 8 screws and lockwashers and the 10 flathead screws.

(3) Rotate the TUNING CONTROL until the setscrew on the shaft gear of the mo subchassis is accessible. Make a note of this position, as shown on the frequency indicator.

### NOTE

If the synchronization of the master-oscillator subchassis is to be maintained, do not disturb the position of the shaft during the succeeding steps or after the subchassis has been removed.

(4) Disconnect plugs P801 and P802 (fig. 2-4) from J101 (fig. 2-7) and J617 (fig. 2-49) and disengage the coaxial cable (terminated in P801) from the spring clips holding it to the exciter.

(5) Remove the regulator assembly (fig. 2-50) from the main frame by loosening the three green captive screws.

(6) Remove the bracket from in front of the regulator assembly by removing the four Phillips screws and lockwashers, and slide the bracket over the cable of the regulator assembly.

(7) Remove the two green screws that hold the tube shield of V801, and remove the tube shield. Remove tube V801.

(8) Remove the spring-type tube shield and tube V802.

(9) Remove the three captive screws holding the mo subassembly to the main frame.

(10) Loosen the setscrew in the gear, being careful not to turn the shaft. Hold the gear while pulling the subchassis back about one-fourth of an inch, and then lift it out, together with the gear.

(11) Tighten the setscrew in the gear and make an index mark on the gear and the subchassis; this will indicate the position of the shaft if it is accidentally turned.

*d. Replacement of Master-Oscillator Subchassis.* To replace the mo subchassis, proceed in the reverse order of removal. If a new subchassis is to be installed, or if for any other reason the setting of the shaft of the subchassis shaft is in doubt, synchronize the shaft (para 3-12).

*e. Removal of Exciter Subchassis.* To remove the exciter subchassis proceed as follows:

(1) Remove the transmitter from its case and remove the back plate.

(2) Turn the PRESET CHANNELS switch to M and manually rotate (after loosening locking bars) the BAND SELECTOR and TUNING CONTROL to 3 megacycles, as indicated on the frequency indicator.

(3) Disconnect plugs P101, P601, and P801 (figs 2-4, 2-7 and 2-49) and from J607 (fig 2-49), J101, and J102 (fig. 2-7).

(4) Loosen the four green captive screws and remove the subchassis by sliding it back; at the same time, disengage the cables of P601 and P801 from the clips on the front of the exciter.

#### NOTE

If the synchronization of the exciter subchassis is to be maintained, do not disturb the position of the two Oldham couplers (fig. 2-10) to which the tuning and switching shafts are connected. Mark their positions in the event they should accidentally be moved.

*f. Replacement of Exciter Subchassis.* To replace the exciter subchassis, proceed in the reverse order of removal. Make sure that in the 3-mc position, the holes in the tuning cams are in line with the slots. Before securing plugs P601 and P801, make sure that their cables are in place on the clips and that these cables are fed through the rectangular hole on the front of the exciter subchassis.

*g. Removal and Replacement of Power-Amplifier Subchassis.* To remove the power-amplifier subchassis, proceed as follows:

(1) Remove the transmitter from its case and then remove the back plate.

(2) Disconnect plugs P201, P205, and P206 (fig. 2-11) from J608, and J618 (fig. 2-53).

(3) Loosen the four green captive screws, and remove the subchassis from the main frame.

#### NOTE

If the synchronization of the power-amplifier subchassis is to be maintained, do not disturb the position of the Oldham coupler to which the switch shaft is connected. Mark its position in the event that it should accidentally be moved.

(4) To replace the power-amplifier subchassis, proceed in the reverse order of removal.

*h. Removal and Replacement of Modulator Subchassis.* To remove the modulator subchassis (fig. 6), proceed as follows:

(1) Remove the transmitter from its case as directed above.

(2) Disconnect plugs P401, P402, and P403 (figs. 2-21 and 2-25) from J601 and J619 (fig. 2-56).

(3) Loosen the seven green captive screws, and lift the subchassis from the main frame.

(4) To replace the modulator subchassis, proceed in the reverse order of removal.

*i. Removal and Replacement of Antenna-network Servo-amplifier Subchassis.* To remove the antenna-network servo-amplifier subchassis, proceed as follows:

(1) Remove the transmitter from its case.

(2) Disconnect plug P901 (fig. 2-28) from J611.

(3) Loosen the two green captive screws, and lift the subchassis from the main frame.

(4) To replace the antenna-network servo-amplifier subchassis, proceed in the reverse order of removal.

*j. Removal and Replacement of Discriminator Subchassis.* To remove the discriminator subchassis, proceed as follows:

(1) Remove the transmitter from its case as directed above.

(2) Disconnect plug P302 (fig. 2-20) from J609 (fig. 2-49).

(3) Loosen the three green captive screws and lift the subchassis from the main frame.

(4) To replace the discriminator subchassis, proceed in the reverse order of removal.

*k. Removal and Replacement of Variable Inductor Subchassis.* To remove the variable inductor subchassis, proceed as follows:

(1) Remove the transmitter from its case and remove the back plate. On main frame MOD 5A and higher, remove the top, of shield.

(2) Disconnect plug P1101 (fig. 2-32) from J612 (fig. 2-49).

(3) Loosen the four green captive screws, move the subchassis slightly backward, disengage connectors J1101 and J1102 (fig. 2-32) from E611 (fig. 2-50) and PS602, and remove the subchassis.

(4) To replace the variable inductor subchassis, proceed in the reverse order of removal.

*l. Removal of Antenna Tuning Capacitor Subchassis.* To remove the antenna tuning capacitor subchassis, proceed as follows:

(1) Remove the transmitter from its case as directed above.

(2) Disconnect plugs P1001 and P1002 (figs. 2-30 and 2-31) from J610 and E611 (figs. 2-49 and 2-50).

(3) Loosen the four green-color coded captive screws and lift the subchassis from the main frame.

*m. Replacement of Antenna Tuning Capacitor Subchassis.* To replace the antenna tuning capacitor subchassis, proceed in the reverse order of removal. During replacement, make sure that plug P303 (fig. 2-20) seats properly with J1001 (fig. 2-30).

*n. Removal of Frequency Indicator Assembly* (figs. 2-55 and 2-56). To remove the frequency indicator, proceed as follows:

#### NOTE

During these procedures, do not rotate the shafts of S605, BAND SELECTOR, and the TUNING CONTROL, because synchronization may be lost.

- (1) Remove the front panel.
- (2) Note the frequency reading of the counter dial, the band setting of the band indicator, and the channel setting of the channel indicator for later reference.
- (3) Remove the mask marked CHAN. BAND by removing the three mounting screws.
- (4) Remove the band indicator disk by removing the three mounting screws.
- (5) Remove the threaded sleeve from the BAND SELECTOR shaft.
- (6) Carefully note the positioning of the shutter lever cam before proceeding with the next step.
- (7) Use a No. 10 fluted socket wrench and loosen the three setscrews on the collar which fastens the cam gear to the BAND SELECTOR shaft. Remove the collar and gear.
- (8) Loosen the setscrew which fastens the channel indicator disk to the shaft of S605. Remove the disk.
- (9) Remove the two mounting screws of the frequency dial lamp assembly, and swing the assembly away from the frequency indicator.
- (10) Remove the four screws which mount the frequency indicator to the main frame.
- (11) Carefully pull the frequency indicator assembly slightly away from the main frame and to the left, to disengage the dial corrector clutch yoke; note the position of the yoke at the back of the dial-corrector gear.

*o. Replacement of Frequency-Indicator Assembly.* To replace the frequency-indicator assembly, reverse the procedures of *n* above, making sure that the channel and band indicator disks, the

frequency indicator, and the shutter lever cam are positioned exactly as noted during removal. When replacement is complete, check the operation of the frequency indicator to see if the counter drum exposed is the correct one for the bands selected.

*p. Removal and Replacement of Autotune Control Head.* To remove the Autotune control head (fig. 2-56), remove the front panel and the frequency indicator. Then proceed as follows:

- (1) Note and disconnect the color-coded wires on the control head terminal board.
- (2) Remove the two slotted screws and one Phillips screw which secure the head to the casting.
- (3) Remove the control head.
- (4) To replace, proceed in the reverse order of removal.

*q. Removal and Replacement of BAND SELECTOR Singleturn Head.* To remove the singleturn head (fig. 2-56) remove the front panel and frequency indicator. Then proceed as follows:

- (1) Loosen the setscrew and free the gear attached to the driven end of the singleturn-head shaft.
- (2) Remove the two slotted-head screws and the one Phillips screw which secure the head to the casting.
- (3) Remove the singleturn head.
- (4) To replace the BAND SELECTOR singleturn head, proceed in the reverse order of removal.

*r. Removal and Replacement of TUNING CONTROL Multiturn Head.* To remove the multiturn head (fig. 2-56), remove the front panel and the frequency indicator. Then proceed as follows:

- (1) Loosen the setscrew and remove the gear attached to the other end of the multiturn-head shaft.
- (2) Remove the two slotted-head screws and the one Phillips screw which secure the head to the casting.
- (3) Remove the multiturn head.
- (4) To replace the multiturn head, proceed in the reverse order of removal.

*s. Removal of Tuned Circuits (Exciter Sub-Chassis).* To remove a tuned circuit (Z101 through Z110, fig 2-10), proceed as follows:

- (1) Remove the exciter subchassis.
- (2) Remove the two slug rack retaining springs (one at each end of the rack) and lift the slug rack from the subchassis. Place the slug rack to one side, taking care not to bend the

wire mounting or change the positioning of the tuning cores.

(3) Remove the four mounting screws which fasten the terminal board to the subchassis; turn the terminal board back, so that the soldered connections of the tuned circuits are accessible.

(4) Unsolder the leads to the tuned circuit being replaced; tag the leads, and mark the location on the subchassis.

(5) Remove the two nuts and lockwashers at the bottom of the tuned circuit below the deck and remove the tuned circuit.

*t. Replacement of Tuned Circuits.* To replace the tuned circuits, proceed in the reverse order of removal. Aline the tuned circuits of the exciter (para 3-10).

*u. Removal of Motors and Dynamotors, or high-voltage power supply A1200 or PS602 or low-voltage transistor-type power supply PS601.*

(1) *Low-Voltage Dynamotor D601 (fig. 2-53).* To remove Dynamotor D601, proceed as follows:

(a) Remove the antenna-network servo-amplifier subchassis (*i* above).

(b) Remove the power-amplifier subchassis (*g* above).

(c) Remove the three Phillips screws that hold the D601 and carefully move D601 away from the main frame enough to expose the leads of D601 and terminals of E602,

(d) Unsolder the leads of D601 from E602 (fig. 2-50).

(2) *High-voltage Dynamotor D602 (fig. 2-53).* To remove Dynamotor D602, proceed as follows:

(a) Remove the back plate from the transmitter.

(b) Remove the eight Phillips screws that hold D602.

(c) Carefully move D602 away from the main frame enough to expose the leads of D601 and terminals of E603 (fig. 2-49).

(d) Unsolder the three leads of D601 from the terminals of E603.

(3) *Autotune motor B601.* To remove Autotune motor B601 (fig. 2-56) remove the front panel, the frequency indicator subchassis, and the exciter subchassis. Remove the end plate next to B601 by taking out the 23 flathead screws. Then proceed as follows:

(a) Unsolder the following six color-coded leads from the terminal board of the motor: the white lead with black and red tracers from terminal A1, the white lead with black and

orange tracers from terminal A2, the white lead and the green leads from terminal F1, and the white lead and the black lead from terminal F2. Tag the leads to prevent wiring mistakes.

(b) Unfasten relay K610 (fig. 2-56) from the main frame by removing the two screws. Do not unsolder any leads from the relay; carefully swing the relay to one side to permit removal of the motor, described in (*c*) below.

(c) Remove the three screws which hold the motor to the main frame.

#### NOTE

To gain access to the bottom screw, it may be necessary to turn the TUNING CONTROL; this uncovers the screw by exposing it through one of the holes in the gear which is driven by the motor pinion gear. If this has to be done, observe the reading on the frequency indicator before changing the gear position. Make sure that the frequency indicator is returned to its original setting before replacing the exciter subchassis.

(4) *Blower motor B602.* To remove motor B602 (fig. 2-56), remove the front panel as follows:

(a) Note and tag the three leads from the terminal board on the blower assembly, and then remove them.

(b) Dismount the blower assembly from the main frame by removing the four screws and lockwashers.

(c) Note, tag, and disconnect the motor brush leads.

(d) Note the locations and positions of the left- and right-hand housings of the blower assembly. Dismount each housing by taking out the three screws together with baffle plate.

(e) Note the locations of the left- and right-hand fans, and remove the fans by loosening the setscrews in their respective hubs.

(5) *Output capacitor motor B603.* To remove motor B603 (fig. 2-49) remove the front panel and the variable inductor subchassis, and proceed as follows:

(a) Note and tag the wiring to the motor, and disconnect the leads from the top and bottom terminal connections by removing the screw at each connection. Replace the screws after disconnecting the leads.

#### NOTE

A dental-type mirror is useful as an aid in disconnecting the wiring from the bottom terminal connection.

(b) Dismount the motor by taking out the two flathead screws which hold the motor to the main frame.

(6) *Blower motor B202.* To remove blower motor B202 (fig. 2-11), remove the power amplifier subchassis and proceed as follows:

(a) Remove the four screws holding the blower housing to the power amplifier subchassis. Remove the blower housing and expose the blower fan (fig. 2-14).

(b) Unsolder the lead from R239. This is the wire wound resistor mounted on the blower mounting plate with the blower. The wire to be unsoldered is connected to the end of the resistor which is farthest from the mounting plate.

(c) Remove the two screws from the blower mounting plate.

(d) Grasp the fan and gently lift the assembly out of the hole.

#### CAUTION

Do not force.

(7) *Homing motor B1102.* To remove homing motor B1102 (fig. 2-32), remove the variable inductor subchassis and proceed as follows:

(a) Note and tag the wiring to the motor, and disconnect the leads from the terminal connections by removing the screw at each connection. Replace the screws after disconnecting the leads.

(b) Dismount the motor by taking out the two flathead screws which hold the motor to the main frame.

*v. Replacement of Dynamotors (fig. 2-53).*

(1) *Low-Voltage Dynamotor D601.* To replace Dynamotor D601, proceed as follows:

(a) Solder the leads of D601 to the terminals of E602 (fig. 2-50): the white lead to terminal 1, the red lead to terminal 2, the blue lead to terminal 3, the green lead to terminal 4, and the black lead to terminal 5.

(b) Bring D601 into place; replace and tighten the three Phillips screws.

(c) Replace the power-amplifier subchassis (*g* above).

(d) Replace the antenna-network servo-amplifier subchassis (*i* above).

(2) *High-Voltage Dynamotor D602.* To replace D602, proceed as follows:

(a) Solder the leads of D601 to the terminals of E603 (fig. 2-49): the black lead to terminal 1, the red lead to terminal 2, and the white lead to terminal 3.

(b) Bring D601 into place; replace and

tighten the eight Phillips screws that hold D601 in place.

(c) Replace the back plate on the transmitter.

*w. Removal and Replacement of Brushes.* Low-voltage dynamotor D601 has four sets of brushes, and the high-voltage dynamotor has two sets of brushes. Of the eight motors in the transmitter, servo motors B201, B1001, and B1101 do not have brushes. Brushes in both dynamotors should be examined after every 500 hours of operation, and should be replaced when the overall length of the brush is less than 50 percent of the overall length of a new brush. Dynamotors D601 and D602 should be lubricated (para 3-3c) during the removal of their brushes for normal inspection. Except where indicated, the replacement procedure for the brushes is the reverse of the removal procedure described below.

#### CAUTION

Before replacing brushes, carefully blow all carbon dust and dirt from the commutator and other motor parts. Do not attempt to remove the discoloration (not to be confused with dirty or pitted commutators) from the commutators, since this is a copper oxide. Install brushes that are polarized (stamped with a positive or negative marking) in brush holders which are similarly marked; install them so that the curved face of the brush fits the curved surface of the commutator. To avoid loss in output voltage, fit the high-voltage brushes of the dynamotor with exceptional care. When brushes with helical springs are employed, install the brush caps with care, so that the springs are not distorted. Observe the standard Signal Corps instructions, MIL-D-24, for correct seating and running-in procedures.

(1) *Low-voltage dynamotor D601.* To remove the brushes in dynamotor D601, remove the dynamotor, but do not unsolder the leads.

(a) Remove the two brush covers by removing the four screws in each cover. Pull the covers off, exposing the three sets of brushes. The speed regulator brushes are on one end, and the +250-volt and the -451-volt brushes are on the other end.

(b) Remove the perforated band around the middle of the dynamotor by removing the

six screws, thereby exposing the set of 24-volt brushes.

(c) Remove and inspect each set of brushes. Replace each set of brushes before removal and inspection of the next set. To remove a brush, unfasten the insulated cap screw, thereby releasing the spring and its brush.

(2) *High-Voltage Dynamotor D602 (Not Used in Radio Transmitter T-195A/GRC-19)*. To remove the brushes in dynamotor D602, first remove the dynamotor but do not unsolder the leads.

(a) Remove the two brush covers, one on each end of the dynamotor, by removing the three screws in each cover. Pull the covers off, exposing the +28-volt-input brush set on one end, and the +1,000-volt-output brush set on the other end.

(b) Remove and inspect each set of brushes. Replace each set of brushes before removal and inspection of the next set. To remove a brush, unfasten the insulated cap screw, thereby releasing the spring and its brush.

(3) *Autotune motor B601*. To remove the brushes in motor B601, first remove the motor, but do not unsolder the leads. To remove each of the two brushes, release the retainer clip, thereby freeing the brush-holder cap.

(4) *Blower motor B602*. To remove the brushes in motor B602, first remove the motor, but do not unsolder the leads. To remove each of the two brushes, unfasten the brush-holder cap.

(5) *Output capacitor motor B603*. To remove the brushes in motor B603, remove the motor.

(a) Remove the cover from the end of the motor to make the brush assembly accessible.

(b) Remove the top brush by lifting up the spring with a pair of long-nosed pliers, and pulling the brush out of its holder. Free the brush lead from the terminal connection by removing the screw.

(c) Using a dental-type mirror, remove the bottom brush by repeating the procedure of (b) above.

(6) *Blower motor B202*. To remove and replace the brushes in motor B202, remove the motor and proceed as follows:

(a) Remove the screw and slide the cylindrical cover from the shaft end of the motor.

(b) Unsolder the two brush leads from their respective terminal connections.

(c) Note the position of the brush housing (opposite to shaft end) in regard to the

polarity, and remove the housing by taking out the two screws.

(d) Remove the brush springs, and take out the brushes.

(e) When replacing the brushes, solder the brush leads to their respective terminals.

(f) Observing the position noted in (c) above, replace the brush cover, and secure it with the two screws.

#### NOTE

Turn the shaft to make sure that the armature rotates freely.

(g) Insert each brush in place, and install the spring in the slot in the brush.

(h) Wrap transparent tape around the brush housing.

(i) Replace the cylindrical cover, and secure the cover with the screw.

(7) *Homing motor B1102*. To remove the brushes in motor B1102, remove the motor but do not unsolder the leads. To provide more play in the wiring, remove the cable clamp which secures the cable of plug P1101. The removal and replacement of the brushes in motor B1101 are identical with the procedures given for blower motor B202.

*x. Removal and Replacement of Lamps*. To remove dial lamp I 601 (fig. 2-55) from behind the band-channel indicator, remove the six screws, and take off the window and its gasket. The bayonet-type lamp is removed by turning it in a counterclockwise direction. To remove dial lamps I 602 and I 603 (fig. 2-55) from behind the frequency indicator, remove the twelve screws and take off the window and its gasket. These lamps are removed in the same way as for I 601. A spare lamp is located on the transmitter framework. To obtain access to this lamp, loosen the sixteen wing nuts on the front panel and pull the transmitter partly out of its case. When replacing the windows of the band-channel indicator and/or frequency indicator, make sure that gasket shellac is first applied to the gaskets to make the windows watertight. To replace TUNING INDICATOR lamp I 605 (fig. 2-55), turn the jewel in a counterclockwise direction and remove the lamp in the same manner as for I 601.

*y. Variable Inductor Ribbon Replacement* (fig. 3-1). If the silver ribbon of the variable inductor should break or become defective in any way, replace it as follows:

(1) Remove the variable inductor subchassis from the main frame.

(2) Remove the retaining ring of gear 3, and remove the gear.

(3) Unsolder the ribbon connections from the terminal on the ceramic coil form and the brass shorting drum. Remove all solder from the coil form and drum terminals.

(4) Solder the end of the replacement ribbon (1) to the terminal of the ceramic coil form (2) (C, fig. 3-1).

(5) Wind 30 turns of ribbon tightly onto the coil form, taking care not to kink or bend the ribbon. Secure the end of the ribbon to the form with tape. Do not cut off the excess length.

(6) Viewing the assembly (B, fig. 3-1), rotate the shorting drum (12) clockwise to the stop, and rotate the coil form so that the arm (6) is positioned as shown.

(7) Remove the tape which holds the free end of the ribbon to the coil form, and thread the ribbon through the slots (7) of the shorting drum (B, fig. 3-1).

(8) Make sure that all turns of the ribbon are tight on the coil form, and that the coil and drum are properly positioned; then bend the end of the ribbon back over the slots. Cut off the excess length of ribbon and solder the end of the ribbon to the terminal.

(9) Hold the coil form and the shorting drum in position; rotate the drum gear (4) in a counterclockwise direction, against the tension of the spring and for a distance of approximately ten gear teeth. Slip gear 3 into position with the flush side of the bearing toward the retaining ring.

(10) Rotate the coil form and the shorting drum counterclockwise to the stop; hold the coil form and the shorting drum in position and perform the following steps:

(a) Remove gear 3.

(b) Rotate gear 4 counterclockwise, against the tension of the spring, to the stop. Allow gear 4 to rotate in a clockwise direction for a distance of three gear teeth; then place gear 3 back in position.

#### NOTE

Check the tension of the ribbon between the coil form and the drum. If the ribbon is slack or too taut, repeat the procedure of (10) above.

(11) Rotate the coil form and the drum clockwise to the stop; then reverse the direction one complete turn (360°). The rotor (9) of switch S1101A (front) should be positioned as shown in D, figure 3-1. If it is not, loosen the

clamp (8) and rotate the rotor until it is positioned properly. Do not allow gear 5 (A, fig. 3-1) to move during this step. When the switch has been adjusted, tighten the clamp.

#### NOTE

It is unlikely that the alignment of the coil form and the drum will be disturbed during the above procedure. However, if the ribbon does not seat properly between the ribs of the coil form during winding, the coil form can be adjusted. Loosen the locking nut (10) (fig. 3-1E) and adjust the bushing (11) so that ribbon tracking is satisfactory. Tighten the locking nut and transfer the ribbon between the coil form and the shorting drum four times. If ribbon tracking remains satisfactory, secure the locking nut with glyptal.

(12) Reinstall the variable inductor subchassis into the main frame.

### 3-2. Disassembly and Reassembly of Autotune Mechanism

#### NOTE

Only those organizations authorized to disassemble the multiturn positioning head should do so.

*a. Disassembly of Band Selector Singleturn Head.* The index numbers (in the following procedure) correspond with those assigned to the exploded view of the singleturn head (fig. 3-2).

(1) Remove the eight Phillips screws (1) and free the right dust cover (2) and left dust cover (3).

(2) Remove the locking key (4).

(3) Remove the wire from the heads of the two spring anchor screws (5); loosen, but do not remove these screws.

(4) Remove the camshaft nut (6) and the No. 10 lockwasher (7).

(5) Remove the four Phillips screws (8) and the four Shakeproof washers (9) from the front-plate assembly (10); remove the assembly and springs.

(6) Remove the two Phillips screws (11), the two lockwashers (12), and the lower-plate standoff (13).

(7) Remove the two Phillips screws (14), the two lockwashers (15), and the upper standoff assembly (16).

(8) Remove the retaining ring (17), retaining ring washer (18), and shims (19) from the camshaft (20).



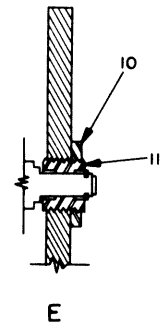
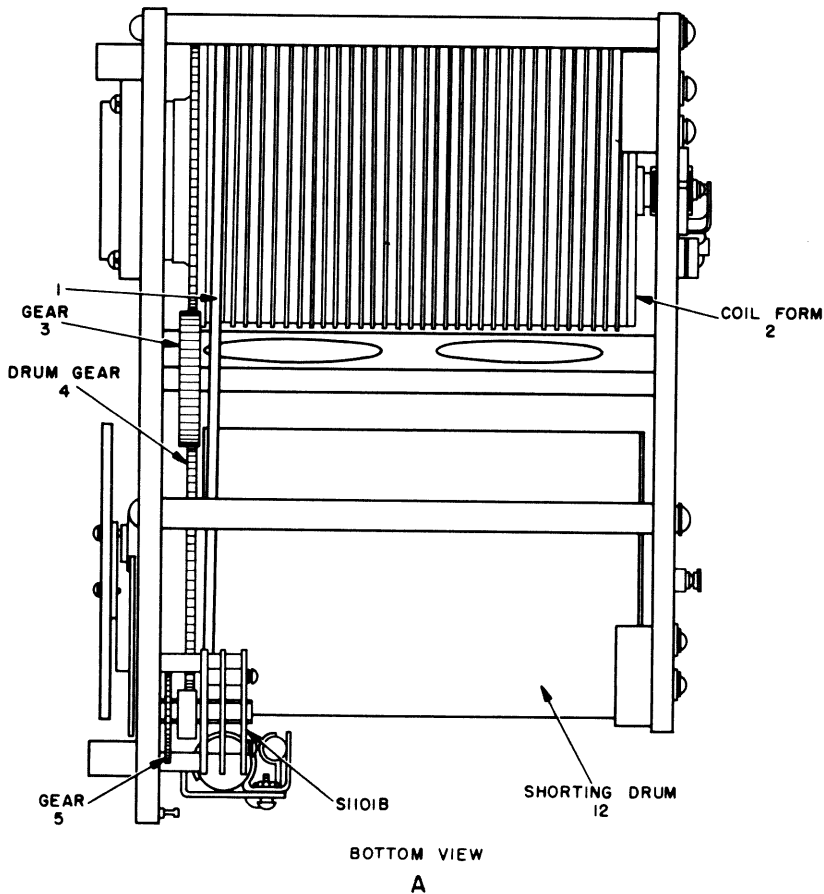
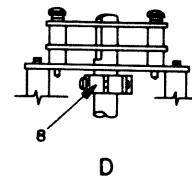
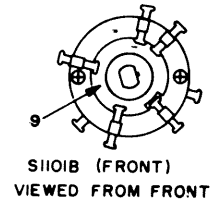
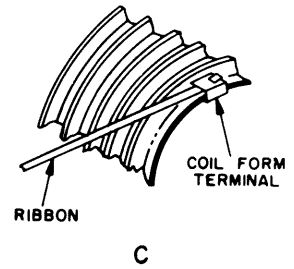
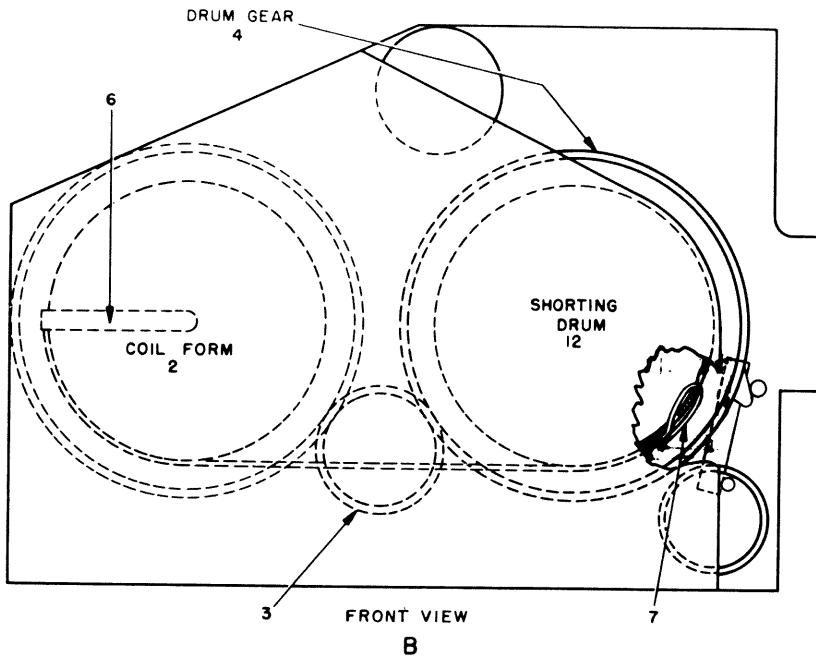

TM 806 -120

Figure 3-1. Variable inductor ribbon replacement.

(9) Remove the pawl-shaft nut (21) and Shakeproof washer (22) from the spring-pawl assembly (23).

(10) Remove the camshaft (20), spring-pawl assembly (23), and stop-ring shaft assembly (24) from the rear-plate assembly (25).

*b. Reassembly of Band Selector Singleturn Head.* The index numbers are the same as those used in the disassembly procedure (fig. 3-2).

(1) Assemble the upper standoff assembly (16), using the two Phillips screws (14) and lockwashers (15).

(2) Assemble the low-plate standoff (13) to the rear-plate assembly (25), using the two Phillips screws (11) and Shakeproof washers (12).

(3) Lubricate the rear ball-bearing assembly (item 24) and the ball-bearing race (25) with Grease, Aircraft and Instruments (GL) MIL-C-3278 or an equivalent, then insert item 24 into item 25.

(4) Screw the spring-pawl assembly (23) into the rear-plate assembly (25).

(5) Insert the two spring anchor screws (5) through the holes in the lower-plate standoff (13), and rotate the screws two turns into the spring anchors.

(6) Remove all the parts from the camshaft (20) and apply a thin film of grease (GL) or an equivalent, to the entire shaft. Replace all the parts and insert the camshaft in the rear-plate assembly (25).

(7) Lubricate the front ball-bearing retainer assembly (item 24) and the ball-bearing race (located in item 10) with grease (GL) or an equivalent. Replace and secure item 10 to the lower-plate standoff (13), using the four Phillips screws (8) and Shakeproof washers (9).

(8) Put the retaining-ring washer (18) and retaining ring (17) on the camshaft (20). Put as many shims (19) as required under item 18 for .002 to .004-inch end play on the camshaft (20).

(9) Put a No. 10 lockwasher (7) and the camshaft nut (6) on the camshaft (20). Hand-tighten the camshaft nut.

(10) Rotate the shaft of spring-pawl assembly (23) so that the pawls aline in the approximate center of the cams on the camshaft (20).

(11) Put the Shakeproof washer (22) and pawl-shaft nut (21) on the spring pawl assembly. Do not tighten the nut (21).

(12) Tighten the spring anchor screws (5), and secure them with safety wire.

(13) Adjust the singleturn head as directed in paragraph 3-6.

(14) Lubricate the head (fig. 3-6).

(15) Coat the threads of the locking key (4) with grease (GL), and insert the key in item 24.

(16) Replace and secure the left dust cover (3) and the right dust cover (2), using eight Phillips screws (1).

*c. Disassembly of Tuning Control Multiturn Head.* The index numbers used in the following procedure correspond with those assigned to the exploded view of the multiturn head (fig. 3-3).

(1) Remove the two Phillips screws (1) and the Shakeproof washers (2).

(2) Remove the twelve Phillips screws (3) that secure the right dust cover (4), the left dust cover (5), and the top dust cover (6).

(3) Remove the locking key (7).

(4) Remove the cam-drum nut (8) and the lockwasher (9). Insert a No. 10 Bristo wrench in the Bristo socket in the end of the shaft to prevent the shaft from rotating. (This is a left-hand thread.)

(5) Remove the safety wires (10) from the four spring anchor screws (11), and remove the screws.

(6) Remove the five Phillips screws (12) and the five Shakeproof washers (13).

(7) Carefully remove the front-plate assembly (14).

(8) Remove the front ball-bearing assembly (15), the felt washer (16), and the home-stop actuator gear assembly (17).

(9) Remove the felt oiler (18) and the camshaft sleeve (19).

(10) Remove the four Phillips screws (20), the four lock washers (21), the upper-right standoff assembly (22), and the upper-left standoff assembly (23).

(11) If the pawls are not in the lifted position, insert a screwdriver into the slot in the front end of the pawl-lifter assembly shaft (24), and turn the shaft clockwise so that the mechanism is actuated and the pawls are lifted.

(12) Remove the cam-drum assembly (25).

(13) Remove the pawl-shaft nuts (26), the Shakeproof washers (27), and the retaining rings (28).

(14) Remove the stop-ring shaft assembly (29), and carefully lay aside the rear ball-bearing assembly (30).

(15) Remove the three Phillips screws (31) and the three lockwashers (32) which hold the lower-plate standoff assembly (33) to the rear-

plate assembly. Remove the lower-plate standoff assembly.

(16) Remove the retaining ring (34), the retaining-ring washers (35), and all the shims (36) under the retaining-ring washers. The camshaft (37) and ratchet-pawl assembly (38) may then be removed from the rear-plate assembly.

(17) Disengage the toggle spring (39) (which holds the pawl-lifter assembly (40) to the rear-plate assembly) from the post (41).

(18) Remove the worn-shaft assembly (42); then remove the worm-gear assembly (43) from the worm-shaft assembly.

(19) Use a No. 10 Bristo wrench and unscrew both pawl shafts, a little at a time, until the shaft assemblies (44 and 45), the home-stop mechanism (consisting of items 47, 48, 49, 50, 51, 52, 53), and the counter-drum (46) can be removed. If the shaft assemblies (44 and 45), and the home-stop mechanism, are to be disassembled, proceed as directed in (20) below; if they are not to be disassembled, proceed as directed in (25) below.

(20) Disengage the stop-ring pawl heels from the counter-drum pawl tails.

(21) Remove the stop-anchor assembly (47) from the counter-drum pawl shaft (44).

(22) Loosen the setscrew (48) on the stop-anchor assembly (47) to remove the push rod (49).

(23) Disengage the push-rod from the home-stop pawl (50) by removing the retaining wire (51) and the push-rod spacer (52).

(24) Free the stop-return spring (53) from the stop-anchor assembly (47).

(25) Remove the shim (54), the cam-drive-gear assembly (55), and the felt washer (56) from the counter-drum assembly (46).

(26) To disengage the toggle spring (57) from the pawl-lifter assembly and remove the pawl-lifter assembly (40) from the rear-plate assembly, remove the snap-ring (58) at the rear of the pawl-lifter assembly shaft (24).

(27) Remove the snap-rings (59) from the post (60) and remove the toggle spring (57).

(28) Use a No. 6 Bristo wrench and loosen the screws (61) and remove the pawl-lifter assembly shaft (24) from the pawl-lifter assembly (41).

*d. Reassembly of Tuning Control Multiturn Head.* The index numbers are the same as those used in the disassembly procedure (fig. 3-3).

(1) Use a No. 6 Bristo wrench and attach the pawl-lifter assembly (40) to the pawl-lifter assembly shaft (24). Tighten the setscrews (61).

(2) Replace the toggle spring (57) on the post (60) and replace the snap-ring (59).

(3) Replace the pawl-lifter assembly (40); then replace the snap-ring (58).

#### NOTE

If the home-stop mechanism has been disassembled, proceed as directed in (4) below; if it has not been disassembled, proceed as directed in (9) below.

(4) Attach the stop-return spring (53) to the stop-anchor assembly (47).

(5) Engage the push-rod (49) with the home-stop pawl (50). Replace the push-rod spacer (52) and the retaining wire (51).

(6) Insert the push-rod (49) in the stop-anchor assembly (47) and tighten the setscrew (48).

(7) Attach the stop-anchor assembly (47) to the counter-drum pawl shaft.

(8) Engage the stop-ring pawl heels with counter-drum pawl tails.

(9) Replace the shim (54), the cam-drive-gear assembly (55), and the felt washer (56) on the counter-drum assembly (46).

(10) Replace the shaft assemblies (44 and 45) (with home-stop mechanism in position) and the counter-drum (46) on the rear-plate assembly simultaneously. Use a No. 10 Bristo wrench and turn the Bristo sockets in the ends of the shafts a little at a time, until the counter-drum pawls are aligned with the counter-drum rings.

(11) Re-engage the toggle spring (39) with the post (41).

(12) Replace the ratchet-pawl (38) on the camshaft (37), and reposition the assembly on the rear-plate assembly. Replace the shims (36), the retaining washer (35), and the retaining ring (34), all of which are associated only with the camshaft assembly.

(13) Replace the worm-gear assembly (43) on the worm-shaft assembly (42).

(14) Replace the worm-shaft assembly on the rear panel. Replace the retaining ring (28).

(15) Replace the shims (36), the retaining-ring washers (35), and the retaining ring (34), all of which are associated only with the counter-drum assembly (46).

(16) Replace the lower-plate standoff assembly (33). Replace the lockwashers (32) and the Phillips screws (31), all of which secure the standoff assembly to the rear-plate assembly.

Make sure that both ends of the spring (53) are positioned in the holes (62) of the lower-plate standoff assembly.

(17) Reattach the rear ball-bearing assembly (30) on the stop-ring shaft assembly (29). Position the stop-ring shaft in place on the rear-plate assembly.

(18) Replace the washers (27) and the pawl-shaft nuts (26); handtighten only.

(19) Replace the cam-drum assembly (25).

(20) Replace the upper-right standoff assembly (22) in position on the rear-plate assembly. Make sure that the counter drum (46) is in a position to insure that the post (on ring gear) will fall between the stops (63) on the standoff assembly.

(21) Replace the camshaft sleeve (19) and the felt oiler (18).

(22) Replace the home-stop actuator gear assembly (17), the felt washer (16), and the front ball-bearing assembly (15).

(23) Replace the front-plate assembly (14).

(24) Replace the five Shakeproof washers (13) and the five Phillips screws (12).

(25) Adjust the position of the pawl stacks until the pawls line up with their respective rings.

(26) Tighten all of the spring-anchor screws (11). Use a 2-inch length of No. 22 wire (10) for each set of screws and make a figure "8" loop through the heads of the screws; twist the ends of the wire together.

(27) Replace the camshaft nut (8) (finger-tight) and its lockwasher (9). Tighten the nut while holding the camshaft in position with the Bristo wrench. (This is a left-hand thread).

(28) Replace the locking key (7).

(29) Replace the two washers (2) and all of the Phillips screws (1).

(30) Synchronize the home-stop mechanism by placing the TUNING CONTROL knob on the multiturn shaft and tightening its setscrews. Replace the locking key, but do not lock. Use a screwdriver and rotate the pawl-lifter shaft (24) clockwise. Rotate the stop-ring shaft clockwise until the home-stop pawl begins to rotate. Stop the rotation before the home-stop pawl has been fully actuated. With a Bristo wrench, loosen the setscrews in the idler gear on the worm-shaft assembly (42). Push this gear back and out of mesh with the drive gear on the stop-ring shaft assembly. Rotate the counter-drum assembly clockwise until the home-stop pawl just contacts the home-stop ring. Rotate the stop-ring shaft clockwise so that the tap on the home-stop ring

just contacts the toe of the home-stop pawl. Mesh the idler gear assembly with the drive gear and tighten the setscrews.

(31) Check the adjustment by rotating the stop-ring shaft to the counterclockwise home-stop position. The toe of the home-stop pawl should fully engage the tab on the home-stop ring. Rotate the stop-ring shaft fully clockwise and then counterclockwise again to check for the same condition. If the adjustment is incorrect, repeat the entire procedure.

(32) Rotate the multiturn shaft counterclockwise until the home-stop is actuated. Now rotate the shaft clockwise until the home-stop is actuated again, while observing whether the slots in any counter-drum rings fail to pass beneath their respective counter-drum pawl toes. With a pointed tool, rotate any misaligned rings about 1/4 turn counterclockwise. Apply pressure, and be careful not to score the ring.

(33) Lubricate the multiturn head as directed in paragraph 3-3.

(34) Replace the right dust cover (4), the left dust cover (5), and the top dust cover (6), using 12 Phillips screws (3).

*e. Disassembly of Autotune Control Head.* After the control head has been removed from the main frame, refer to figure 3-4 and accomplish the following disassembly procedure. The index numbers used in the procedure described in (1) through (23) below correspond to those assigned to the parts in the figure.

#### NOTE

Only those organizations authorized to disassemble the Autotune control head should do so.

(1) Remove the eight Phillips screws (1); then remove the right dust cover (2) and the left dust cover (3).

(2) Loosen the setscrew (4) and pull the channel indicator (5) off its shaft.

(3) Remove the three Phillips screws (6) and separate the terminal board (7) from the control head.

(4) Remove the Phillips screw (8) and pull the seeking switch (9) forward off its shaft. Do not unsolder any wires at this time unless necessary for repair.

(5) Remove the two Phillips screws (10) and Shakeproof washers (11), the two studs (12) and lockwashers (13).

(6) Carefully pull the front plate (14) forward until it is disengaged from the main shaft

(7) Unscrew the nut (15) and then pull the lug (16) off the end of the screw.

(8) Unsolder and tag all of the wires connected to the terminals of the breaker switch (17), the reverse switch (18), and the limit switch (19).

#### NOTE

Do not unsolder the wires from seeking switch or the terminal board unless they need repair.

(9) Remove the two Phillips screws (20) and the two lockwashers (21), and separate the breaker switch (17) from the front plate (14).

(10) Remove the two screws (22), and separate the top casting (23) from the rear plate (24).

(11) Remove the two retaining rings (25 and 26) from the end of the main shaft (27) and the bearing (28).

(12) Disengage the main shaft (27), with its attached parts, from the rear plate (24).

(13) Loosen the set screw (29) and slide the cam (30) off the main shaft (27).

(14) Slide the ratchet-and-gear assembly (31) off the main shaft (27).

(15) Slide the bearing (28) out of the ratchet-and-gear assembly.

(16) Remove the retaining ring (32) from the groove in the main shaft (27).

(17) Slide the bushing (33), with its attached parts, off the main shaft (27).

(18) Remove the retaining ring (34) from the bushing (33).

(19) Slip the shims (35), the spring washer (36), the special washer (37), the spacer (38), and the actuator arm (39) off the bushing (33).

(20) Slide the lost-motion washers (40) off the main shaft (47).

(21) Remove the two screws (41) and separate the rear plate (24) from the bottom casting (42).

(22) Remove the two Phillips screws (43) and the Shakeproof washers (44), and separate the bracket (45) from the bottom casting.

(23) Remove the four Phillips screws (46) and the lockwashers (47), and separate the reverse switch (18) and the limit switch (19) from the bracket (45).

*f. Reassembly of Autotune Control Head.*  
After this control head has been disassembled, repaired, and cleaned, refer to figure 3-4 for the reassembly procedure that follows. The index numbers assigned to parts in the procedure in

(1) through (24) below are identical with those used during the disassembly procedure (fig. 3-4).

(1) Properly position the reverse switch (18) and the limit switch (19) on the bracket (45). Secure these two switches to the bracket; use the four Phillips screws (46) and four lockwashers (47).

(2) Secure the bracket (45) to the bottom casting (42); use the two Phillips screws (43) and two Shakeproof washers (44).

(3) Attach the rear plate (24) to the bottom casting (42); use the two screws (41).

(4) Slide the lost-motion washers (40) onto the main shaft (27).

(5) Slide the actuator arm (39), the spacer (38), the special washer (36), and the shims (35) onto the bushing (33).

(6) Insert the retaining ring (34) into its slot in the bushing (33).

(7) Slide the bushing (33), with its attached parts, onto the main shaft (27).

(8) Insert the retaining ring (32) into its slot in the main shaft (27).

(9) Slide the bearing (28) into the ratchet-and-gear assembly (31).

(10) Slide the ratchet-and-gear assembly (31) onto the main shaft (27).

(11) Slide the cam (30) onto the main shaft (27) and secure with the setscrews (29).

(12) Insert the end of the main shaft (27) and the bearing (28) properly into their holes in the rear plate (24), and secure them in position with the retaining rings (25 and 26).

(13) Properly position the top casting (23) and secure it to the rear plate (24) with the two screws (22).

(14) Properly position the breaker switch (17) on the front plate (14), and secure with the two Phillips screws (20) and the two lockwashers (21).

(15) Properly solder all removed wires to the terminals of the breaker switch (17), the reverse switch (18), and the limit switch (19). Make sure that as each wire is replaced, it corresponds to the terminal from which it was removed, as tagged upon removal.

(16) Replace the lug (16) on end of the screw, and secure with the nut (15).

(17) Replace the front plate (14), engaging the bearing in the front plate with the main shaft (27), and secure with the two studs (12), the two Shakeproof washers (13), the two Phillips screws (10), and the two lockwashers (11). Make certain that the rubber grommet

(48) with the contained cabling is properly inserted into its slot in the front plate.

(18) Carefully slide the seeking switch (9) onto the main shaft (27), and secure it to the front plate (14) with one Phillips screw (8).

(19) Properly position the terminal board (7) and secure in place with the three Phillips screws (6).

(20) Slide the channel indicator (5) onto the main shaft (27) and secure with the setscrew (4).

(21) Rotate the main shaft (27), using the gear of the ratchet assembly (31). All of the parts, with the exception of the slip-clutch action of the actuator arm, should rotate freely without binding. While rotating the main shaft, make sure that the breaker switch (17) snaps open simultaneously with an open position on the seeking switch (9). It may be necessary to temporarily loosen the setscrews (29) and reposition the cam (30) on its shaft. Make sure that the lost-motion washers (40) become effective between limits approximately 2 1/4 revolutions of the spur gear.

(22) Lubricate the control head as directed in paragraph 3-6.

(23) Replace the left dust cover (3) and secure with the four Phillips screws (1).

(24) Replace the right dust cover (2) and secure with the four Phillips screws (1).

*g. Disassembly of Autotune Motor* (fig. 3-5). After the Autotune motor has been removed, disassemble as follows:

(1) Drive out the taper pin (1) and remove the spur gear (2).

(2) Remove the two retainer clips (3), the brush-holder caps (4), and the brushes (5).

(3) Remove the two frame screws (6), the two lockwashers (7), and the front housing (8).

(4) Feed the field leads (9) through the hole in the rear housing (10) and remove the frame-and-field assembly (11).

(5) Pull the armature (12) from the rear housing (10) and remove the bearings (13 and 14).

(6) Remove the two screws (15) and the two lockwashers (16); then remove the filter cover (17).

*h. Reassembly of Autotune Motor.*

(1) Wearing rubber gloves, remove the prelubricated bearings (13 and 14) from their packages, and press them on the shaft of the armature (12).

(2) Insert the armature assembly into the rear housing (10), making sure that the bearing (14) is properly seated.

(3) Feed the field leads (9) through the hole in the rear housing (10) and place the frame-and-field assembly (11) in position.

(4) Replace the front housing (8) in position and secure with the two frame screws (6) and the lockwashers (7).

(5) Insert the two brushes (5), the brush-holder caps (4), and the retainer clips (3). Observe standard Signal Corps instruction for correct seating and running-in procedures.

(6) Place the spur gear (2) on the end of the shaft (hub inward) and secure with the tapered pin (1).

(7) Replace and secure the filter cover (17), using the two screws (15) and the two lockwashers (16).

### 3-3. Lubrication

The only items of the transmitter that require lubrication are the frequency indicator (fig. 3-11) the Autotune mechanism (figs. 3-6 through 3-10), the gear train in the main frame, the gears in the antenna tuning capacitor subchassis (fig. 2-31), the variable inductor subchassis (fig. 2-32), the power-amplifier subchassis (fig. 2-11), the slug-rack system in the exciter subchassis (fig. 2-10), and the dynamotors. The transmitter is lubricated initially at the factory and should be lubricated thereafter once every 6 months under normal operating conditions. The lubrication interval should be shortened only if inspection indicates the need, or if abnormal conditions are encountered. When the equipment is operated in a hot, arid climate, it may be necessary to lubricate the oillite bearings about twice as often as indicated. Overlubrication can often cause more harm than no lubrication. Inspect the mechanical tuning system whenever the transmitter is withdrawn from the case for servicing. Rotate the TUNING CONTROL and BAND SELECTOR controls manually throughout their ranges, noting ease of operation. Check for lack of lubrication on gears, edges of cams, cam followers, cam-follower guide slots, and bearings; inspect for gritty grease and oil. While operating the transmitter, check for excessively noisy or irregular Autotune and automatic tuning (servo system) operation.

#### CAUTION

Never attempt to lubricate the master-oscillator subchassis during turning. Un-

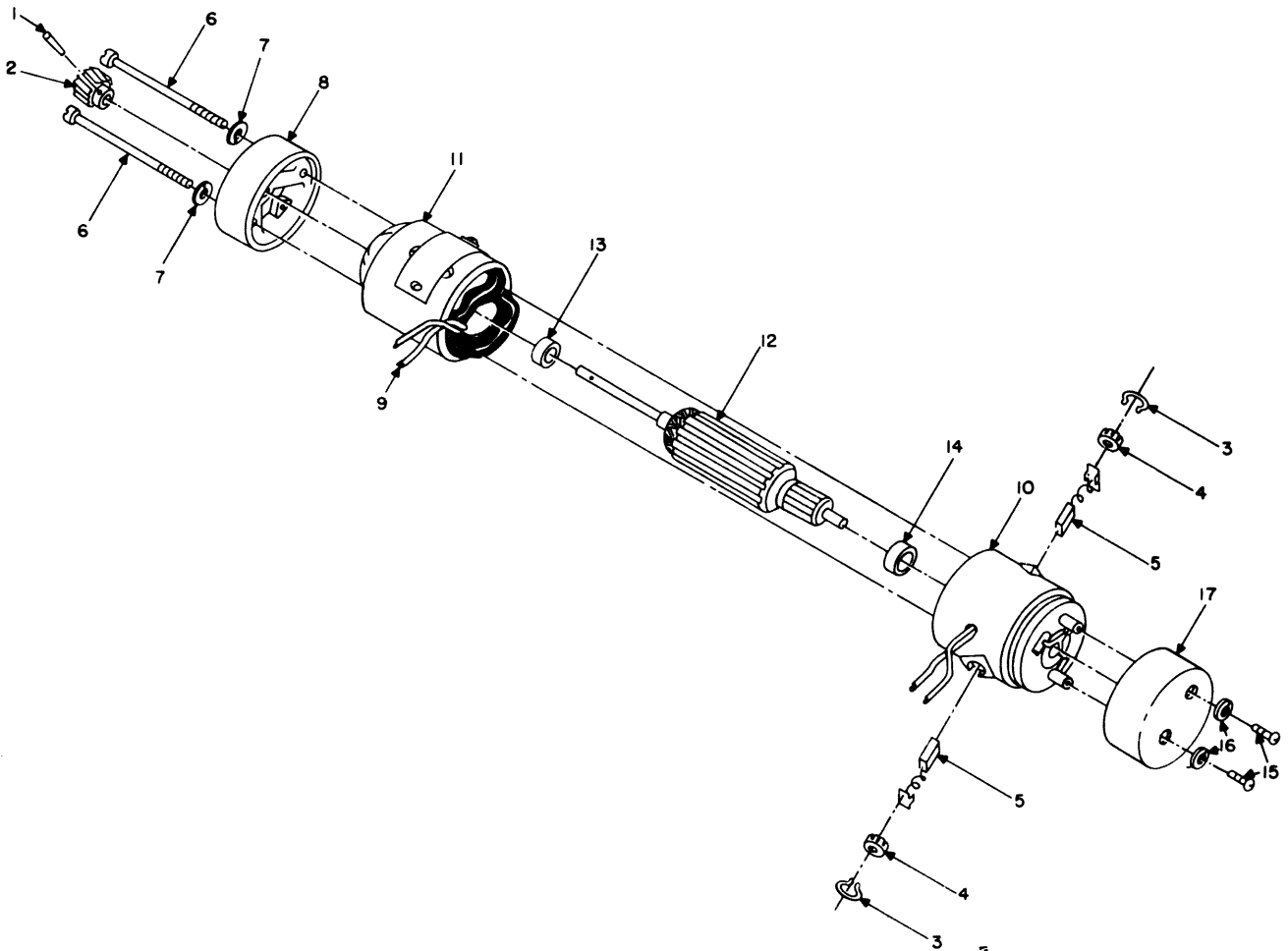

TM 806-118

Figure 3-5. Disassembly of Autotune Motor.

stable operation of the oscillator may result.

*a. Cleaning Before Lubrication.* Remove the transmitter from its case by loosening the 16 wingnuts and carefully pulling the transmitter forward. If the frequency indicator is to be lubricated, the front panel must be removed (para 3-1a). If the Autotune mechanism is to be lubricated, the frequency indicator must also be removed to permit access to the gear train. Use a thin, long-handled brush having medium bristles, dipped in solvent (SD). Remove the dirt, oil, and grease from the gears, cams, guide slots, and bearings. To gain access to all of the gear teeth while cleaning, rotate the BAND SELECTOR and TUNING CONTROL knobs. After dipping the brush in solvent (SD), remove the excess to prevent the solvent from dripping onto connecting cables, wiring, or other

electrical parts. Use a clean, lint-free cloth moistened with solvent (SD) to remove grease from the metal casting and chassis. Thoroughly wipe all parts with a clean, dry, lint-free cloth before proceeding with lubrication. It is necessary to clean the Autotune mechanism before lubrication only if excessively noisy or irregular operation indicates dirt in the mechanism. The same cleaning procedures apply to the subchassis and main frame gear trains. Remove the master-oscillator, exciter, power-amplifier, antenna tuning capacitor, and variable inductor subchassis as directed in paragraph 3-1, exposing the main frame gear train (figs. 2-50 and 2-51).

*b. Detailed Lubrication Instructions.* If any item or part of the transmitter is not mentioned in this paragraph, it needs no lubrication for the lifetime of the transmitter. To apply grease to

REMOVE FROM CASTING  
TO SERVICE

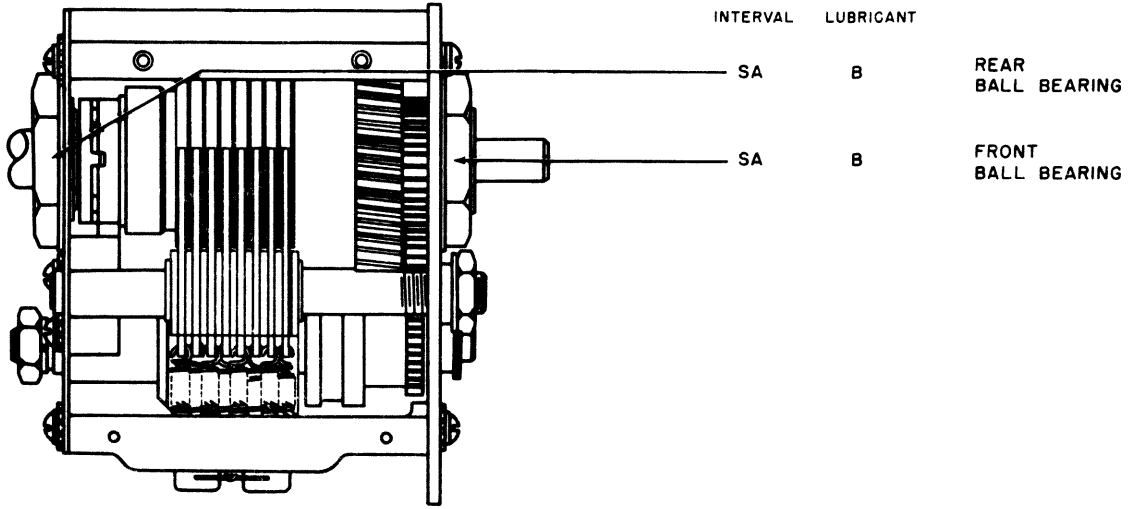

NOTE:  
ALL LUBRICANTS ARE TO BE APPLIED USING A SMALL CAMEL HAIR BRUSH, IN AMOUNTS WHICH EACH LUBRICATION POINT WILL RETAIN. REMOVE ALL EXCESS.

LUBRICANT	INTERVAL
A-AN-O-6a OIL	SA-SEMIANNUALLY
B-MIL-G-3278 GREASE	

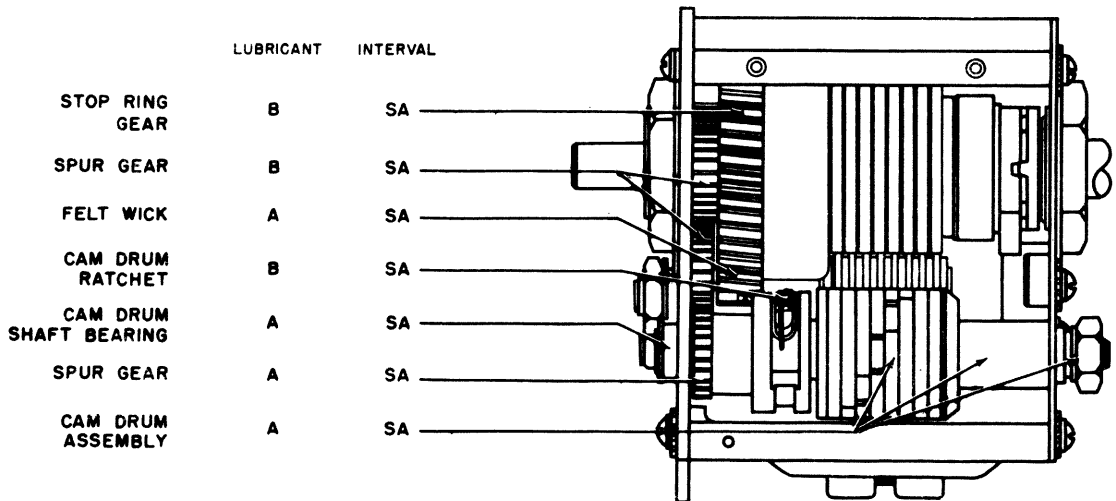

TM 806-89

Figure 3-6. Lubrication of Autotune Singleturn Head.



the teeth of the gears in the main frame, and in the subchassis mentioned in *a* above, use a standard grease gun and a thin, long-handled brush. The same technique should be used in applying grease to the cam edges and guide slots of the cam followers (fig. 2-10). The two cam followers should each be lubricated with a drop of lubricating oil. In applying oil, dip a length of wire into the oil to collect a small drop at the end, and transfer the oil to the bearing by touching the end of the wire to the edge of the bearings. Avoid excessive amounts of oil. Lubricate the Autotune mechanism as indicated in figures 3-6 through 3-10. Rotate the singleturn and multiturn shafts as necessary to expose all gear teeth for lubrication. The frequency indicator is lubricated as indicated in figure 3-12. The roller surface and teeth of the detent wheel should be lubricated with MIL-G-3278 grease semiannually. The bearing of the roller should be lubricated with AN-0-6a oil semiannually.

#### CAUTION

Make sure that no oil or grease collects on the surfaces of the slip clutch (fig. 2-31) of the antenna tuning capacitor and the dial corrector clutch face (fig. 3-11) of the frequency indicator.

*c. Lubrication of Dynamotors.* The dynamotors should be lubricated at the end of every 1,000 hours of operation except where the bearings are permanently sealed. Lubricate low-voltage dynamotor D601 and high-voltage dynamotor D602 as follows:

#### NOTE

Radio Transmitter T-195/GRC-19 uses a transistorized high voltage power supply instead of dynamotor D602. No lubrication is required for this power supply.

(1) Wipe all dust and dirt from the fan and bearing brackets with a clean, dry cloth, and blow out all dust from the armature.

(2) Remove the fan and bearings caps.

(3) Remove the old grease from the bearing caps, and repack bearings with grease equivalent to grease (GL).

#### CAUTION

Add only enough grease to fill the bearings level with the races. Do not overfill. Keep the grease off the commutators, and avoid smearing dirt on them.

### 3-4. Parts Lubricated by Manufacturer

Prior to delivery of Radio Transmitter T-195/GRC-19, the following parts are lubricated by the manufacturer:

*a.* Gears, cams, and guide slots—grease GL or an equivalent.

*b.* Bearings and cam followers—Lubricating Oil, General Purpose, Low Temperature, MIL-L-7870.

*c.* Autotune mechanism—Oil, Lubricating, Preservative, Special (PL Special) MIL-L-644A, and Grease, Aircraft and Instruments, MIL-G-3278.

REMOVE FROM CASTING TO SERVICE

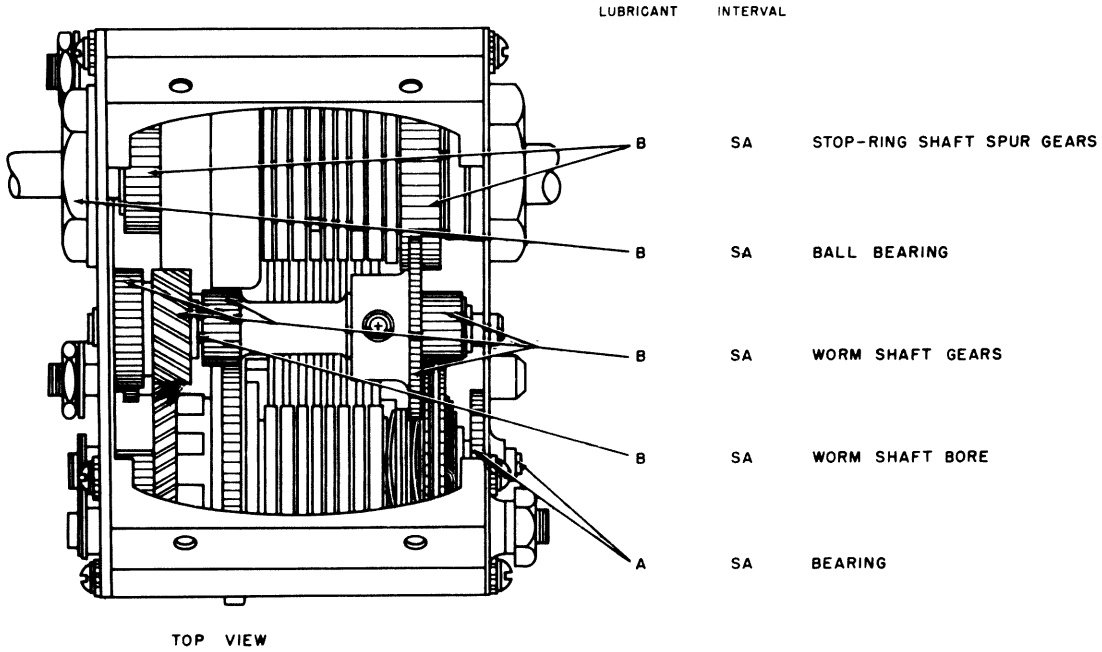

NOTE

ALL LUBRICANTS ARE TO BE APPLIED, USING A SMALL CAMEL HAIR BRUSH, IN AMOUNTS WHICH EACH LUBRICATION POINT WILL RETAIN. REMOVE ALL EXCESS.

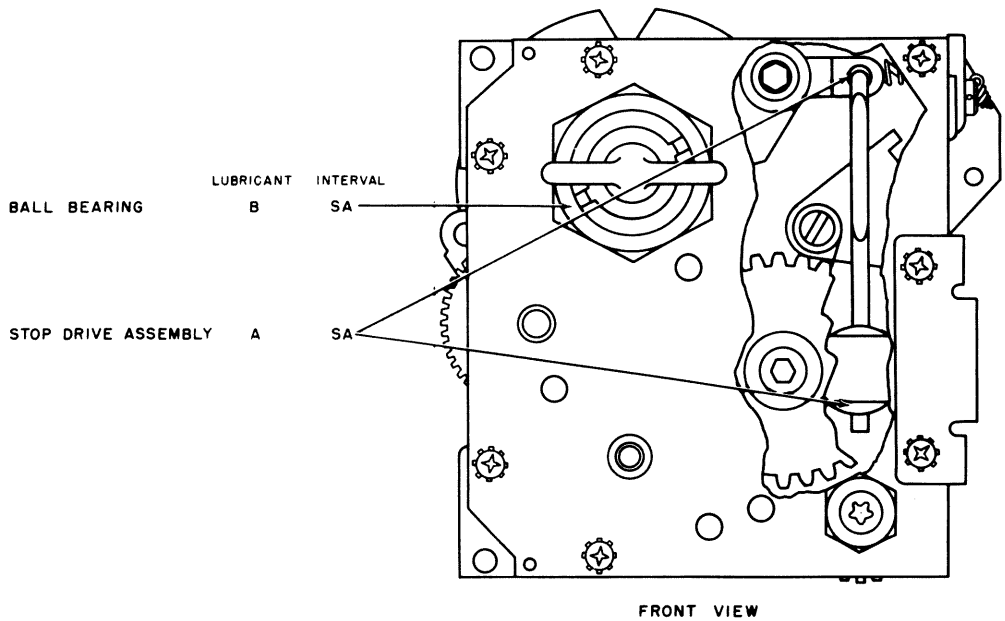

LUBRICANTS	INTERVAL
A-AN-O-6a OIL	SA-SEMIANNUALLY
B-MIL-G-3278 GREASE	

Figure 3-7. Lubrication of Autotune multiturn head, front and top views.

REMOVE FROM CASTING TO SERVICE

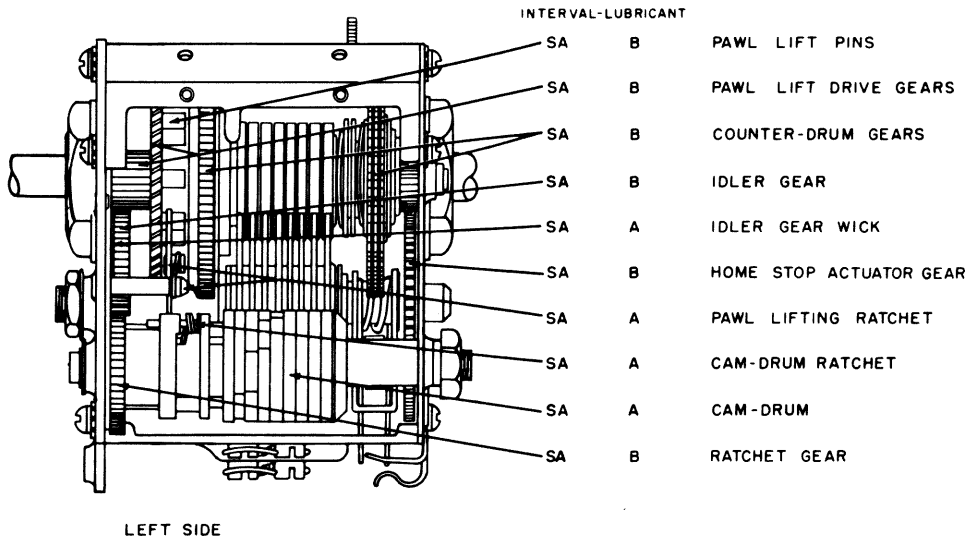

NOTE  
 ALL LUBRICANTS ARE TO BE APPLIED, USING  
 A SMALL CAMEL HAIR BRUSH, IN AMOUNTS  
 WHICH EACH LUBRICATION POINT WILL RETAIN.  
 REMOVE ALL EXCESS.

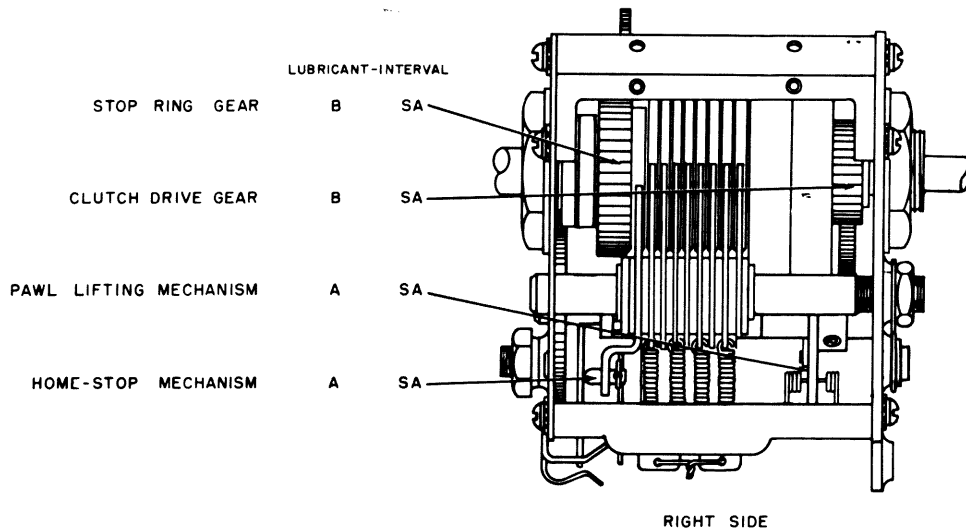

LUBRICANTS	INTERVAL
A-AN-O-6a OIL	SA-SEMIANNUALLY
B-MIL-G 3278 GREASE	

TM 806-112

Figure 3-8. Lubrication of Autotune multiturn head, left and right views.

REMOVE FROM CASTING  
TO SERVICE

NOTE

ALL LUBRICANTS ARE TO BE APPLIED, USING A SMALL CAMEL HAIR BRUSH, IN AMOUNTS WHICH EACH LUBRICATION POINT WILL RETAIN. REMOVE ALL EXCESS.

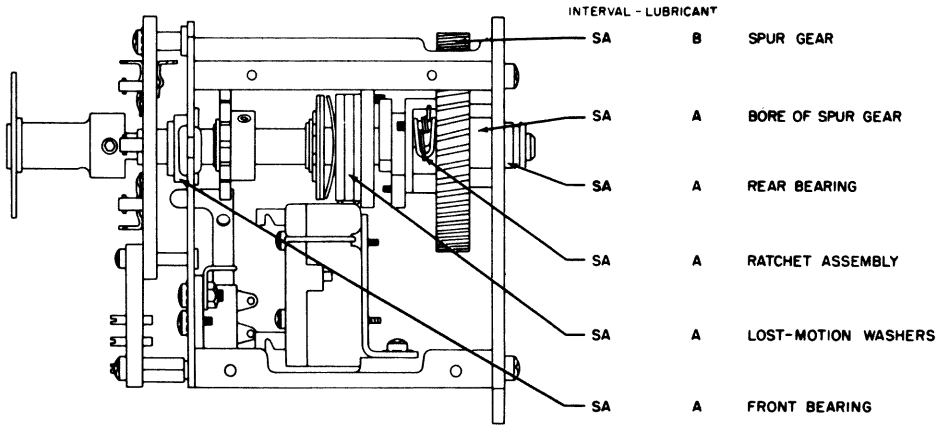

LUBRICANTS		INTERVAL
A	AN-O-6d OIL	SA-SEMIANNUALLY
B	MIL-G-3278 GREASE	

TM 806-110

Figure 3-9. Lubrication of Autotune control head.

REMOVE FROM CASTING TO SERVICE

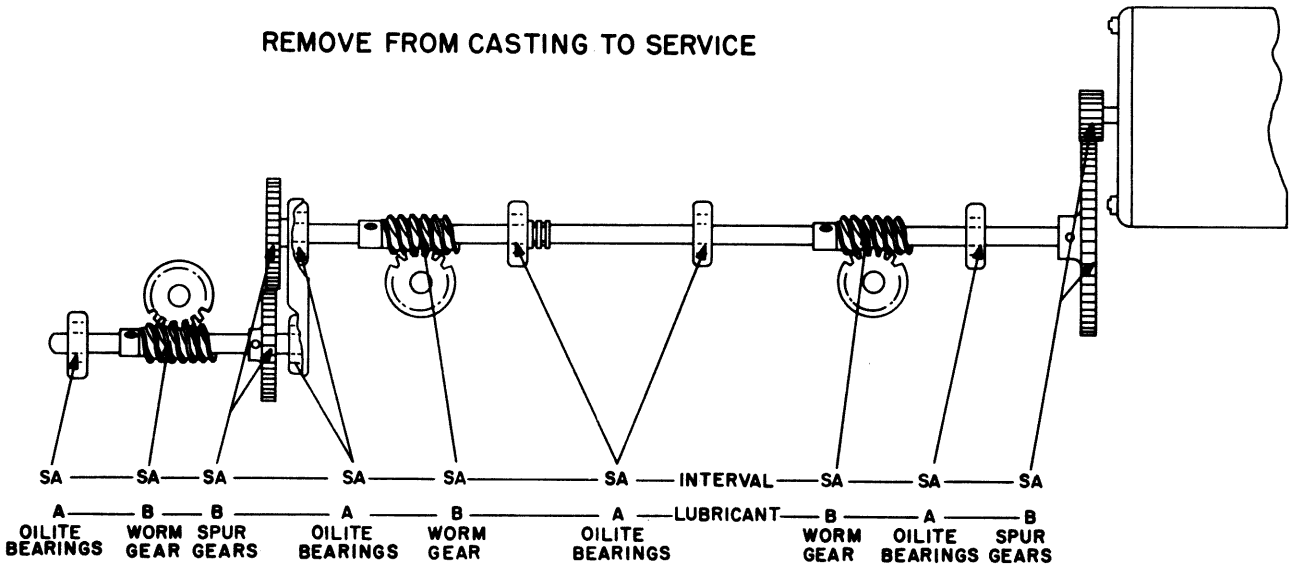

LUBRICANTS		INTERVAL
A	AN-O-6a OIL	SA-SEMIANNUALLY
B	MIL-G-3278 GREASE	

NOTE

ALL LUBRICANTS ARE TO BE APPLIED, USING A SMALL CAMEL HAIR BRUSH, IN AMOUNTS WHICH EACH LUBRICATION POINT WILL RETAIN. REMOVE ALL EXCESS.

TM 806-109

Figure 3-10. Lubrication of Autotune line shaft.

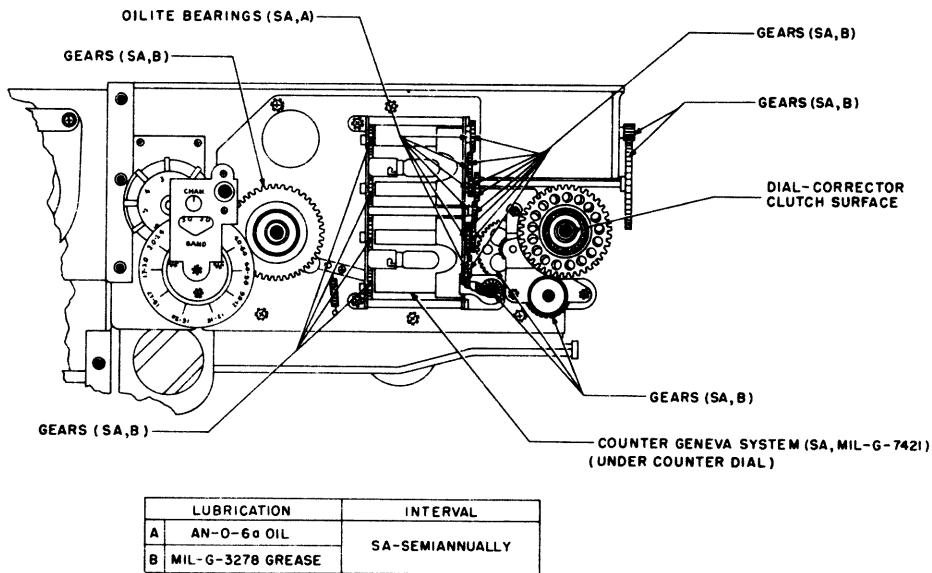

LUBRICATION		INTERVAL
A	AN-O-6a OIL	SA-SEMIANNUALLY
B	MIL-G-3278 GREASE	

TM806-96

Figure 3-11. Lubrication of frequency indicator.

NOTE:

ON MAIN FRAME MOD5A AND HIGHER, A PERFORATED METAL, RF SHIELD COVERS THE END PLATE OPENING TO THE VARIABLE INDUCTOR.

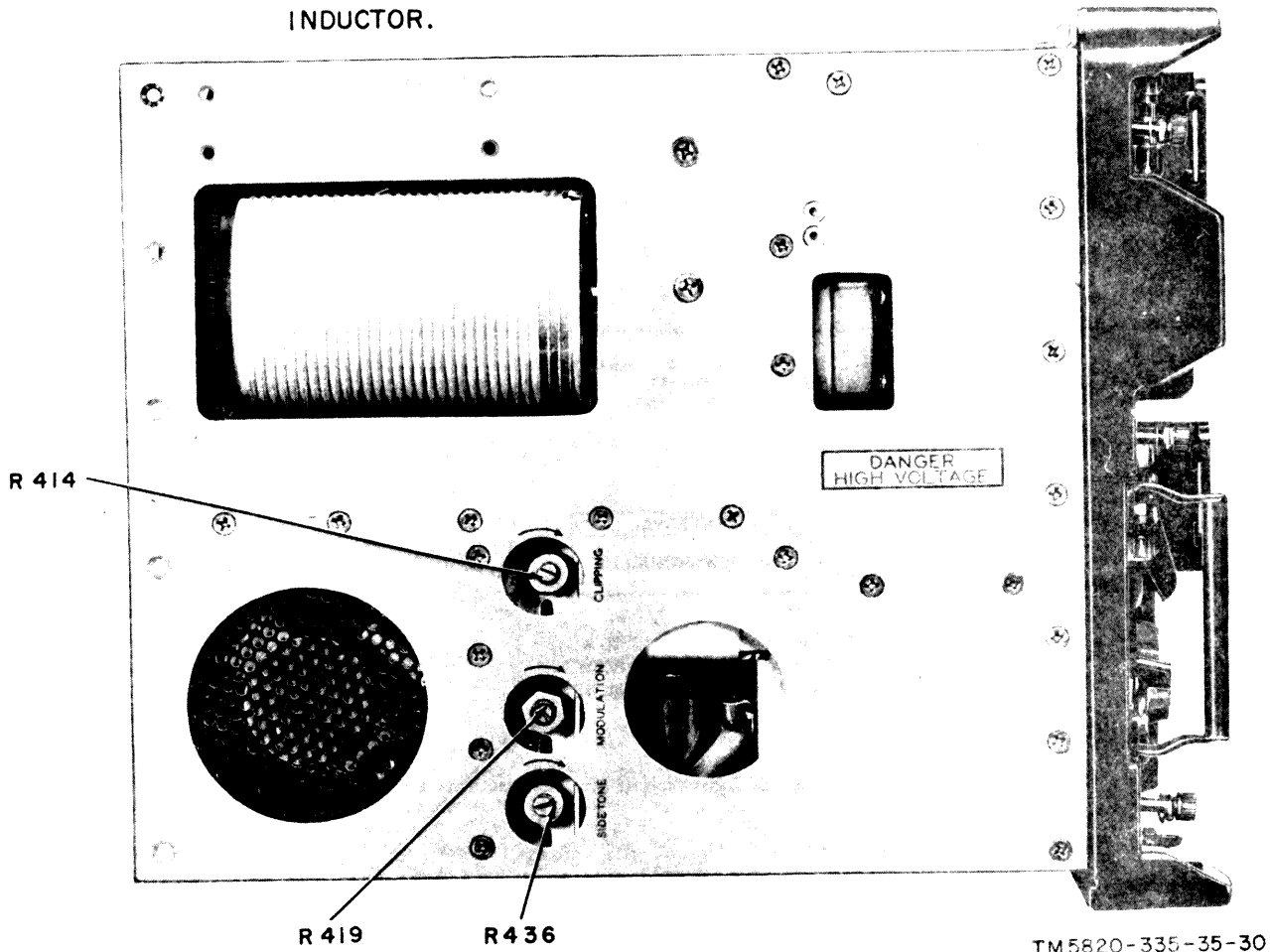

Figure 3-12. Radio Transmitter T-195/GRC-19, modulator adjustments.

**Section II. ALINEMENT**

**3-5. Test equipment and special tools required**

Refer to para 2-4 for details of test equipment required for alinement and adjustment of Radio Transmitter T-195/GRC-19. In addition to the test equipment, the following test devices and special tools are required:

a. Two noninductive resistors: one 73.5 ohms, 140 watts; and one 660 ohms,  $\pm 5$  percent, 5 watt; and the capacitors mentioned in paragraph 3-11. These items are required for the alinement and testing of discriminator subchassis.

**NOTE**

To produce the 73.5 resistor, connect two 147-ohm  $\pm 5$  percent, 115-watt non-inductive resistors. (Federal stock No. 5905-088-3693) in parallel. To produce the 660-ohm resistor connect one 150-ohm  $\pm 5$  percent, 5 watt resistor (Federal stock No. 5905-107-7122), and one 510-ohm  $\pm 5$  percent 5 watt resistor (Federal stock No. 5905-107-7096) in series.

b. A bakelite alinement tool for adjusting the inductor cores and trimmer capacitors of the tuned circuits of the exciter subchassis.

c. A 0.248 to 0.249-inch diameter rod for the mechanical adjustment of the exciter subchassis.

d. Paragraph 8 in TM 11-5820-335-20 lists other tools required for maintenance and the location of tube puller stored inside the transmitter case.

### 3-6. Synchronization of Autotune Mechanism

The synchronization of the Autotune system involves the adjustment of the angular positions of the cam drums and seeking switch S605 (fig. 2-56). This adjustment insures the proper selection of the channel chosen by the switch. After any repairs have been made to either the singleturn or multiturn head or to the control head, the Autotune system should be synchronized. Before replacing the front panel, synchronize the Autotune mechanism by following the procedure in the order given in *a*, *b*, and *c*, below:

#### a. Autotune Control Head.

(1) Loosen the *T*-handles on both Autotune heads.

(2) Insert a No. 10 Bristo wrench into the end of the line shaft. When facing the gear at the end of the line shaft, rotate the line shaft counterclockwise until any rotor contact of the control unit switch is on the verge of contact with a stator contact. With additional shaft rotation, the breaker switch tab in the control unit proceeds with an audible snap to the extreme left position. Stop rotation of the line shaft immediately at this point. The preceding operation may be accomplished at any of several successive positions during the switch rotation.

(3) Rotate the line shaft clockwise  $3\frac{1}{2}$  to  $3\frac{5}{8}$  revolutions from the position located; then stop.

(4) Rotate the shaft on each Autotune head clockwise until the stop is reached; then counterclockwise until the stop is reached. The *T*-locking bars are still loose at this point.

(5) Tighten the *T*-locking bars on both Autotune heads. Try to turn the knobs. If either knob rotates with the *T*-locking bars tightened, it will be necessary to repeat (1) through (3) above until no rotation occurs when the heads are locked.

b. *Autotune Multiturn Head.* Insert a No. 10 Bristo wrench into the end of the cam drum shaft of the Multiturn Autotune and rotate the cam

drum counterclockwise as far as possible. While holding the cam drum in this position, loosen the cam drum nut by rotating the nut clockwise. Again rotate the cam drum counterclockwise as far as possible. While holding the cam drum in this position, tighten the cam drum by rotating the nut counterclockwise, using from 10 to 15 inch-pounds of torque.

c. *Autotune Singleturn Head.* Insert a No. 10 Bristo wrench into the end of the cam drum shaft of the Singleturn Autotune, and rotate the cam drum clockwise as far as possible. While holding the cam drum in this position, loosen the cam drum nut by rotating the nut counterclockwise. Again, rotate the cam drum clockwise as far as possible. While holding the cam drum in this position, tighten the cam drum nut by rotating the nut clockwise, using from 10 to 15 inch-pounds of torque.

### 3-7. Adjustment of Modulator Subchassis

a. Remove the transmitter from its case and set it up for voice operation as directed in paragraph 20 of TM 11-5820-355-10. Make sure that interlock switch S611 is closed; one method of activating the switch is to pull out the plunger.

b. Check to see that the input line voltage is between 28 and 29 volts dc; then operate the transmitter for voice as directed in paragraph 20 of TM 11-5820-335-10.

c. Turn the RELAY-NORMAL-DUPLEX switch to RELAY, and set the LINE LEVEL control to -34.

d. Connect an audio oscillator to pin H of AUDIO receptacle J604, and set the oscillator to deliver an output of .015 volt root mean square (rms) at a frequency of 1,000 cycles.

#### NOTE

Extreme care must be taken to insure that all circuits associated with this input circuit are adequately shielded and grounded, since this setting of the LINE LEVEL control means that maximum modulator gain is available. Inadequate shielding or grounding will result in rf feedback.

e. Turn CLIPPING control R414 (fig. 3-12) to its CCW stop and adjust MODULATION control R419 (fig. 3-12) so that meter M603 indicates 100 percent. The 100-percent indication is obtained when the modulator is delivering 707 volts rms output. Lock R419.

f. Turn CLIPPING control R414 in a clockwise direction until the indication on meter M603 decreases to 80 percent. Lock R414.

g. The output from the sidetone amplifier may be adjusted to any convenient value by adjusting SIDETONE control R436 (fig. 3-12).

h. If an audio oscillator is not available, the above procedure may be performed by using a microphone (M-29/U) and speaking at a normal level with a sustained note, such as a long, drawn-out "hellooooooo."

### 3-8. Synchronization of Band Switch in Exciter Subchassis

Whenever the exciter subchassis is replaced and the synchronization of band switch S101 with the BAND SELECTOR control is lost (as shown on the band-channel indicator), realine band switch S101 as follows:

a. Loosen the clamp screw that holds the exciter band-switch coupler to the band switch shaft.

b. Set exciter band switch S101 to the 1.5- to 1.7-mc band (see fig. 3-13 for switch positions).

c. Mount the exciter in the transmitter frame and engage the band-switch and cam-shaft couplers.

d. Insert a screwdriver in the slot at the rear of the band-switch shaft of the exciter so that the shaft does not move, and rotate the BAND SELECTOR control to the 1.5- to 1.7-mc range.

e. Tighten the exciter band-switch coupler clamp.

f. Loosen the clamp screw which secures the camshaft coupler.

g. Set TUNING CONTROL to 3 mc.

h. Lift the exciter slug rack and turn the cams (fig. 2-10) so that a 0.248 to 0.249-inch diameter rod may be inserted through both exciter end-plate slots and through the holes in the cams.

i. Tighten the camshaft clamp screw, remove the rod, and complete the replacement of the exciter subchassis in the main frame.

### 3-9. Synchronization of Bank Switch in Power Amplifier Subchassis

If the power amplifier subchassis is removed or replaced, the band switch can be synchronized as follows:

a. With the power amplifier subchassis removed from the transmitter, adjust band-switch shaft so that the red arrow on the rear of the switch lines up with the red line (fig. 2-15).

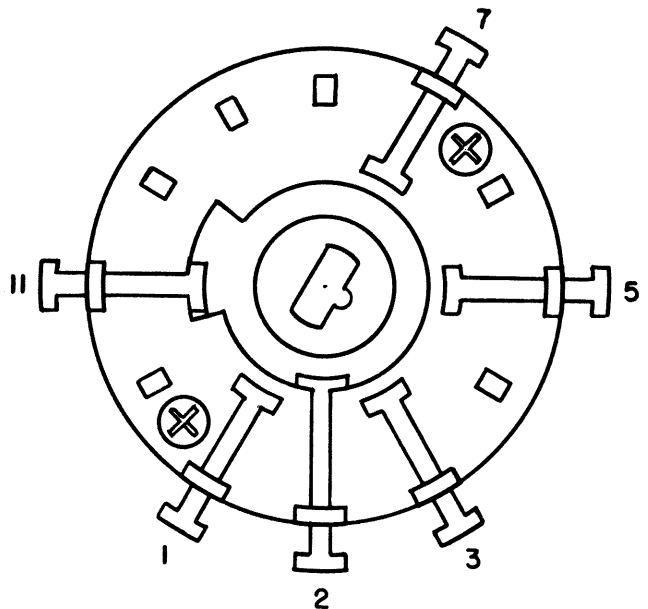

S101A  
VIEWED FROM REAR OF  
EXCITER AND POSITIONED  
FOR 1.5 TO 1.7 MC RANGE

TM806-C4-1

Figure 3-13. Exciter Bandswitch Synchronizing Position.

This will adjust the switch to the 1.5- to 1.7-mc range position.

#### NOTE

In figure 2-15, the cover plate has been removed. It is not necessary to remove the plate, however, because a hole has been provided in it also.

b. Note the position of the cam of S203 (fig. 2-14). The switch arm should be exactly centered in a detent of the cam. Adjust if necessary.

c. Use a No. 10 Bristo wrench and loosen the setscrew of the clamp which fastens the Oldham coupler (fig. 2-14) to the BAND SELECTOR shaft.

d. At the front panel of the transmitter, note the band setting of the BAND SELECTOR, for later reference. Loosen the BAND SELECTOR locking key, and rotate the knob to the 1.5- to 1.7-mc range position.

e. Install the power amplifier subchassis onto the main frame; be careful not to change the position of the band-switch shaft. Engage the Oldham coupler snugly and tighten the clamp. The power amplifier band switch should now be



properly synchronized with the other BAND SELECTOR components.

f. With the locking key still loosened, rotate the BAND SELECTOR back to the original position noted in *d* above; then lock the key.

### 3-10. Alinement of Exciter Subchassis (fig. 2-7)

The variable capacitors and coils for alinement of the turned circuits of the exciter are accessible through holes in the slug rack of the exciter subchassis. To aline the exciter subchassis, proceed as follows:

a. Turn all slug studs on coils L101 through L110 so that they extend about 1/16 inch above the top of the slug rack surface.

b. Set the SERVICE SELECTOR switch to CALIBRATE and the TEST METER switch to PA GRID.

c. Set the BAND SELECTOR control to the 1.5-1.7 MEGACYCLE BAND and the TUNING CONTROL to 1.500 MEGACYCLES. Adjust capacitor C136 for maximum indication on the PA GRID scale of the meter.

d. Set the BAND SELECTOR control to the 3.0-4.0 MEGACYCLE BAND and the TUNING CONTROL to 3.000 MEGACYCLES. Adjust capacitors C107, C111, and C138 for maximum indication on the PA GRID scale of the meter.

e. Set the BAND SELECTOR control to the 6.0-9.0 MEGACYCLE BAND and the TUNING CONTROL to 6.000 MEGACYCLES. Adjust capacitors C118, C122, and C140 for maximum indication on the PA GRID scale of the meter.

f. Set the BAND SELECTOR control to the 12-16 MEGACYCLE BAND and the TUNING CONTROL to 12.000. Adjust capacitors C129, C131, and C141 for maximum indication on the PA GRID scale of the meter.

g. Set the BAND SELECTOR control to the 2.4-3.0 MEGACYCLE BAND and the TUNING CONTROL to 2.900 MEGACYCLES. Adjust coil L107 for maximum indication on the PA GRID scale of the meter.

h. Set the BAND SELECTOR control to the 4.0-6.0 MEGACYCLE BAND and the TUNING CONTROL to 5.800 MEGACYCLES. Adjust coils L103, L104, and L109 for maximum indication on the PA GRID scale of the meter.

i. Set the BAND SELECTOR control to the 9.0-12 MEGACYCLE BAND and the TUNING CONTROL to 10.500 MEGACYCLES. Adjust coils L103, L104, and L109 for maximum indication on the PA GRID scale of the meter.

j. Set the BAND SELECTOR control to the 16-20 MEGACYCLE BAND and the TUNING CONTROL to 19.200 MEGACYCLES. Adjust coils L105, L106, and L110 for maximum indication on the PA GRID scale of the meter.

k. Repeat *c* through *j* above until no further adjustment of the capacitors or coils is necessary to give maximum indication on the PA GRID scale of the meter. These adjustments usually must be repeated three or four times.

### 3-11. Adjustment and Testing of Discriminator Subchassis

For the purposes of this adjustment, the discriminator subchassis is divided into two sections. The section of the discriminator which includes L304A, CR303, CR304, and C305 (fig. 1-34) will be referred to as the *loading discriminator*. Its dc output appears at pin F of P302. The section containing L304B, CR301, and CR302 (fig. 1-32) will be referred to as the *phasing discriminator*. The dc output of the phasing discriminator appears at pin B of P302. The only section of the discriminator which requires adjustment is the loading discriminator. However, before the adjustment of the discriminator subchassis can be considered satisfactory, both the loading and phasing sections should be tested. For this reason, both an adjustment procedure and a testing procedure are provided.

#### a. Discriminator Adjustment.

(1) Remove the discriminator subchassis as directed in paragraph 3-1. Connect bench-test cable No. 4 (fig. 2-1) between P302 (fig. 2-20) and J609 (fig. 2-49).

(2) Loosen the antenna-tuning capacitor subchassis from the transmitter frame. Disconnect it from the variable inductor and the discriminator subchassis, and move the antenna-tuning capacitor subchassis so that it projects from the rear of the transmitter. Keep plug P1001 (fig. 2-30) connected, and place the antenna-tuning capacitor subchassis in a free-operating position at the rear of the transmitter.

(3) Prior to discriminator adjustment and testing, it is advisable to check CR301, CR302 (fig. 2-18), CR303, and CR304 for faults.

(4) Between the discriminator rf output (P303) and ground (the point at which the antenna-tuning capacitor normally connects to the discriminator), connect the 73.5-ohm resistor which will act as the rf load.

(5) Remove discriminator plug P302 and insert a piece of wire in J609-F (described in

(paragraph 2-5a), and reconnect plug P302. Connect a 20,000 ohms-per-volt meter between the wire and ground. Set the meter to its 2.5 volt dc scale.

(6) Close switch S611. Rotate the SERVICE SELECTOR switch to its CW position, set the TUNING CONTROL and BAND SELECTOR control for 12,000 kilocycles (kc), connect the 73.5-ohm load to the discriminator, and close the TEST KEY.

(7) The dc meter connected to pin F of P302 and ground should indicate  $\pm 0.02$ -volt dc. If the correct indication is not obtained, adjust C305 (fig. 2-18) until the proper residual error occurs. This adjustment should be the only one necessary in the alignment of the entire discriminator.

*b. Discriminator Testing.*

(1) *Loading discriminator.* Testing of the loading discriminator after its adjustment requires the same equipment set-up as for adjustment. The testing procedure is as follows:

(a) At 1,700 kc, shunt the rf load with a 660-ohm  $\pm 5$  percent noninductive resistor at the discriminator rf output. Shunting the 73.5-ohm load with the 66-ohm resistor introduces a 10 percent change in the resistive component of the load to the power amplifier. This change in power-amplifier load should appear as a change in the dc output of the loading discriminator at pin F of P302. To indicate satisfactory operation of the loading discriminator, the total change of dc output voltage should be equal to, or greater than, the residual error voltage.

(b) To determine whether the loading discriminator is operating satisfactorily, it must be further tested at 3,000 kc, 12,000 kc, and 20,000 kc. With the transmitter operating at 3,000 kc, the residual error voltage at pin F of P302 should be noted. It will vary from that obtained at 1,700 kc, but the condition is normal, and no further adjustment of C305 should be made. The rf load should then be shunted at the discriminator rf output with the 660-ohm resistor. As in (a) above, the total change in error voltage should be equal to, or greater than, the error voltage. For example, if the residual error voltage at 3,000 kc is +0.05 volt, and shunting the 3,000-kc load with a 660-ohm resistor changes this error voltage to +0.27 volt, the total change in error voltage is 0.22 volt. Since 0.22 volt is greater than 0.05 volt, the loading discriminator is operating satisfactorily at 3,000 kc.

(c) At 17,000 and 20,000 kc, the discriminator rf load should be 73.5 ohms. In each case,

the change in error voltage is compared to the residual error and should be equal to, or greater than, the typical error. The following typical readings are given for an example:

Frequency (kc)	Typical error voltage (volts)	Error voltage with a 600-ohm shunt (volts)	Change in error voltage (volts)
1,700-----	+0.03	+0.14	0.11
3,000-----	+ .05	+ .27	.22
12,000-----	*0	+ . 6	.6
20,000-----	+ .15	+ .75	.6

\*This value set by adjustment of C305.

(2) *Phasing discriminator.*

(a) The procedure for testing the phasing discriminator is almost the same as that used for testing the loading discriminator; however, no initial adjustment is necessary, and a capacitor is used to shunt the rf load.

(b) At 1,700 kc, connect the 73.5-ohm rf load across the discriminator rf output and note the dc error voltage at pin B of P302. Shunt the rf load with a 128-micro-microfarad ( $\mu\mu\text{f}$ ) capacitor and note the total change in error voltage. The total change in error voltage must be equal or greater than the typical error for satisfactory operation. Repeat the above procedure for 3,000; 12,000; and 20,000 kc, using the shunts indicated below. Typical data for the phasing discriminator are as follows:

Frequency (kc)	Typical error voltage (volts)	Value of shunting capacitor ( $\mu\mu\text{f}$ )	Error voltage when shunted with capacitor (volts)	Change in error voltage (volts)
1,700-----	-0.05	128	+0.03	0.08
3,000-----	0	73	+ .13	.13
12,000-----	- .25	18	+ .15	.40
20,000-----	- .05	11	+ .35	.40

NOTES

1. Difficulty in obtaining satisfactory discriminator performances can usually be attributed to incorrect discriminator rf loads, transmitter operating frequency not set accurately, and, in the case of the phasing discriminator, CR301 and CR302 not sufficiently well balanced.

2. To produce the 128- $\mu\mu\text{f}$  capacitor, connect one 18- $\mu\mu\text{f}$  capacitor (Federal stock No. 5910-101-4496) and one 110- $\mu\mu\text{f}$  capacitor (Federal stock No. 5910-112-7757) in parallel.

### 3-12. Alinement and Calibration of Master-oscillator Subchassis

When replacing the master-oscillator subchassis with a subchassis from supply, or if the mechanical relationship between the tuning shaft of the subchassis and the TUNING CONTROL setting has been disturbed during removal or replacement (para 3-1), aline the master-oscillator subchassis as follows:

#### CAUTION

Extreme care must be taken with the master-oscillator shaft to make certain that it is never forced against its end stops. *a* through *h* below are to be performed with the master oscillator completely unmeshed from the multiturn head.

*a.* Set the BAND SELECTOR control to the 16.0- to 20.0-mc range, as indicated on the band-channel indicator.

*b.* Lock the tuning control multiturn head by tightening the T-locking bar on the TUNING CONTROL knob.

*c.* Set the DIAL ZERO control to the midpoint of its range.

*d.* Set the BAND SELECTOR control to the 1.5- to 1.7-mc range.

*e.* Unlock the TUNING CONTROL knob and rotate it counterclockwise until the Autotune stop is reached.

*f.* At this time, the counter should indicate a frequency of 1.445 mc. If the counter does not indicate a frequency within this range, loosen the setscrews that tighten the counter clutch (bank of four gears) to the tuning control multiturn head, and rotate the entire bank of four gears with respect to the Autotune shaft until a reading between 1.440 and 1.450 is obtained on the counter when the tuning control multiturn head is at its counterclockwise stop position. Tighten the setscrews.

*g.* Turn the SERVICE SELECTOR switch to the CALIBRATE position and allow the mo subchassis a 10-minute warmup period, then measure the output frequency of the transmitter as outlined in paragraph 15 of TM 11-5820-335-10. See that the fundamental frequency is measured.

*h.* Set the TUNING CONTROL to indicate this measured fundamental frequency and lock the TUNING CONTROL knob.

*i.* Insert the mo subchassis into its position in the main frame, and mesh the loaded gear on

the mo shaft (with 2-tooth loading) to the TUNING CONTROL Autotune shaft gear. Do not tighten the setscrews in the hub of the loaded gear until it has been determined that the mo frequency and counter indication are in agreement. If they are not in agreement, rotate the TUNING CONTROL with the loaded gear slipping on the mo shaft until the counter indicates the mo frequency. Tighten the setscrews in the mo loaded gear.

*j.* Rotate the TUNING CONTROL slowly over its range and determine that no binding occurs, then complete the replacement of the mo subchassis.

### 3-13. Adjustment of Speed Regulator

The speed regulator for the 115-volt, 400-cps output consists of a centrifugal-type switch (governor) located on one shaft end of low-voltage dynamotor D601. When the rotation of the shaft decreases beyond a certain speed, contacts on the governor open; this introduces a resistor (located internally) in series with the 24-volt input winding of D601. Field current and flux are lowered, causing the speed of rotation to increase. When the rotation of the shaft increases beyond a certain speed, centrifugal force causes the contacts to close and short out the resistor. The resultant increase in field current and flux will decrease the speed of rotation. To check the speed of rotation of the dynamotor and adjust the governor, proceed as follows:

*a.* Connect a 600-ohm, 50-watt resistor between ground and terminal 4 (the 115-volt, 400 cps output), and connect a 5,000-ohm, 2-watt resistor between ground and terminal 2 (the 250-volt dc output), and connect a 5,000-ohm, 2-watt resistor between ground and terminal 3 (the -45-volt dc output). Replace the power cable and secure the dynamotor to the main frame, or carefully place the dynamotor in such a position that it cannot move. Check to see that all exposed wiring or parts are properly insulated or clear of any grounded point, then turn the SERVICE SELECTOR switch to CALIBRATE. Connect the 400-cps output, located at terminal 3 of E602 (fig. 2-50) to the vertical plates of an oscilloscope, and connect the 400-cycle output from an audio signal generator to the horizontal plates. If necessary, vary the audio oscillator frequency to obtain a 1:1 ratio figure, such as a diagonal line, a circle, or an ellipse, on the screen of the oscilloscope. If the audio oscillator setting does not fall between 380 and 420 cycles, proceed with the next step.

b. Remove the brush cover on the input side of the dynamotor to expose the governor. The governor should be moved to a position where its operating contact is on the right. If the dynamotor rotates too fast, the top facing screw should be turned once in a clockwise direction; if the speed of rotation is too slow, the screw should be turned once in a counterclockwise direction. The bottom facing screw permits greater range of speed adjustment; it should only be used when the top facing screw cannot provide speed compensation. Adjust the governor until the audio oscillator reading is between 380 to 420 cps for a 1:1 ratio figure on the oscilloscope.

### 3-14. Adjustment of Frequency-indicator Assembly (fig. 2-56)

Proper adjustment of the frequency-indicator assembly requires synchronization of the counter dial shutter mechanism, band indicator, and channel indicator with the BAND SELECTOR switch to indicate bands and channels correctly.

a. *Channel Indicator.* To adjust the channel indicator disk, proceed as follows:

(1) Remove the front panel of the transmitter.

(2) Use a No. 10 fluted socket wrench and loosen the setscrew which fastens the channel indicator disk to the shaft of S605.

(3) Rotate the channel indicator disk so that the channel position, to which the PRESET CHANNELS switch is positioned, can be read through the opening in the mask marked CHAN. BAND.

(4) Tighten the setscrew, making certain that the disk does not rub the band indicator disk or the gear. Replace the front panel.

b. *Counter-Dial Shutter Mechanism.* To adjust the counter-dial shutters, proceed as follows:

(1) Rotate the PRESET CHANNELS switch to the M (manual) position.

(2) Loosen the locking key on the BAND SELECTOR knob, and rotate the BAND SELECTOR knob, and rotate the BAND SELECTOR to the 1.5- to 1.7-mc range.

(3) Remove the front panel.

(4) Use a No. 10 fluted socket wrench and loosen the setscrew that fastens the collar of the cam gear to the BAND SELECTOR shaft. Do not rotate the BAND SELECTOR shaft.

(5) Disengage the cam gear from the band indicator disk gear, and rotate the cam gear in a counterclockwise direction until the first shut-

ter snaps closed, and the last or bottom shutter opens. The shutter lever roller must ride on the cam during this step.

(6) Depress the shutter lever to open the first shutter, and rotate the cam gear in a clockwise direction until the cam holds the first shutter open. Engage the band indicator disk gear with the cam gear, and tighten the setscrew of the cam gear.

(7) Secure the BAND SELECTOR knob to the shaft, leaving the locking key loose. Rotate the BAND SELECTOR to both limits, in turn, to check the shutter operation.

(8) If the shutter operation is satisfactory, remove the BAND SELECTOR knob and replace the front panel. If the shutter operation is not satisfactory, repeat the procedure, beginning with (2) above, and readjust as necessary.

c. *Band indicator.* To adjust the band indicator disk, proceed as follows:

(1) Rotate the PRESET CHANNELS switch to the M (manual) position.

(2) Loosen the locking key on the BAND SELECTOR knob, and rotate the BAND SELECTOR to the 1.5- to 1.7-mc range.

(3) Remove the front panel.

(4) Use a No. 10 fluted socket wrench and loosen the setscrew that fastens the collar of the cam gear to the BAND SELECTOR shaft. Do not disturb the cam setting with regard to the shutter lever of the counter-dial mechanism.

(5) Move the cam gear slightly forward, so that the band-indicator disk rotates freely and adjust the disk to indicate 1.5- to 1.7-mc.

(6) Move the cam gear back to engage the band-indicator gear, and tighten the setscrews.

(7) Replace the front panel.

### 3-15. Adjustment of Antenna-Tuning Capacitor

a. Adjustment of the antenna-tuning capacitor consists of setting the switches for the following conditions.

(1) S1001 must be open except when S1002, C1002, and C1003 are at minimum or maximum capacity position and there is torque on B1001.

(2) S1003 must be operated when S1002 is at minimum capacity position.

(3) C1002 and C1003 must reach minimum and maximum capacity positions before S1002.

b. Adjust as follows:

(1) Remove antenna tuning capacitor sub-chassis from the main frame as outlined in paragraph 3-1.

(2) Rotate the gear (which drives S1002) by hand to the last detent position of S1002. This will be the position at which only one contact (C1003) touches the contacting bar of S1002.

(3) Loosen the two mounting screws of S1003 and adjust S1003 so that it is operated properly without undue tension when the gear that drives S1002 is rotated against spring tension until S1001 closes as shown in figure 3-14.

(4) Check that C1002 and C1003 are at minimum capacity (plates out of mesh). If either capacitor does not reach minimum, loosen the clamp that fastens the gear to the shaft of the faulty capacitor. Rotate the capacitor to minimum, and retighten the clamp.

(5) Replace the subchassis onto the main frame.

### 3-16. Synchronization of Output Capacitor

Synchronization of the output capacitor consists of adjusting S612 and S614. These switches must be properly positioned with respect to each other, and with respect to the BAND SELECTOR. Check synchronization of band switch in exciter chassis (para. 3-8) before performing this adjustment.

Proceed as follows:

a. Remove the variable inductor subchassis as outlined in paragraph 3-1.

b. Note the setting of the BAND SELECTOR on the BAND indicator, then loosen the locking key and rotate the BAND SELECTOR to the 12-16 mc band.

c. Connect an ohmmeter between the junction of C653, C663, and C656 and the rotor arm of S612A. Rotate the large gear (which meshes with the small gear on the shaft of the dc motor (B603)) by hand until a continuity reading is obtained. Center the contacts at this position.

d. Connect the ohmmeter between contact 9 of S614A rear and ground. (See note below.) No

continuity should be obtained. If it is, loosen the clamp which fastens the switch gear to the rotor shaft of S612; then rotate the large gear (c above) until an open circuit is obtained. At this position, S614B rear should appear as in figure 3-15. Make certain that the switch contacts are exactly centered at this position and retighten the clamp.

#### NOTE

Locate contact 9 of S614B rear. Contact 9 of S614A rear will be in line with it.

e. Return the BAND SELECTOR to the BAND setting noted in b above, then tighten the locking key. Replace the variable inductor subchassis.

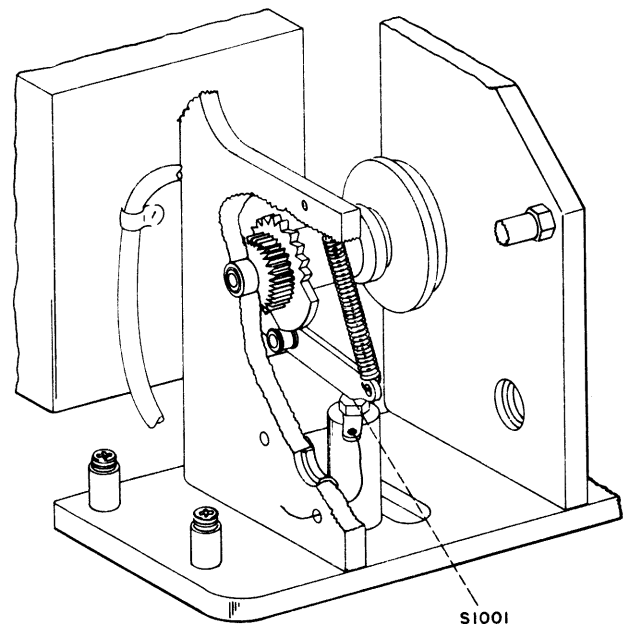

S1001  
VIEWED FROM REAR OF  
ANTENNA TUNING CAPACITOR AND SET  
AT MINIMUM CAPACITY POSITION

TM 806-124

Figure 3-14. Antenna tuning capacitor synchronization.

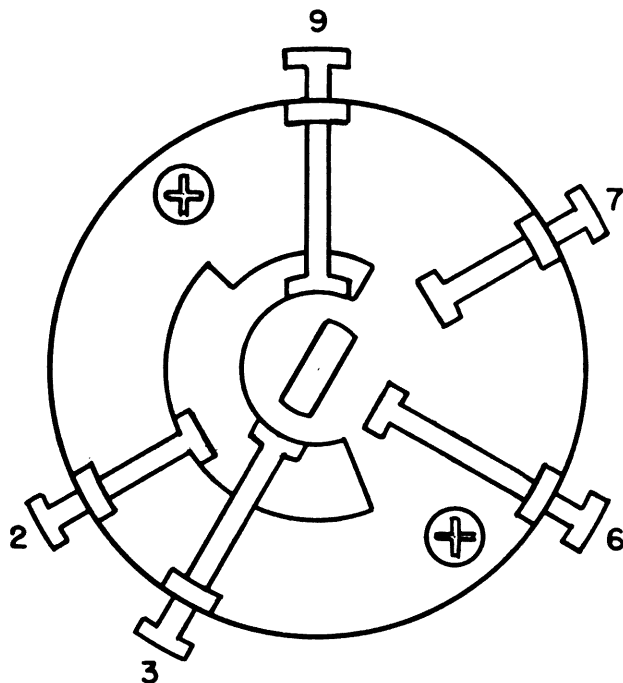

**S614B**  
**VIED FROM REAR OF**  
**SWITCH S614 AND POSITIONED**  
**FOR THE 12-16 MC RANGE**

TM5820-335-35-31

*Figure 3-15. Output capacitor synchronization.*

## CHAPTER 4

### GENERAL SUPPORT MAINTENANCE

---

#### **4-1. Maintenance Instructions**

The duties of general support maintenance are to test, aline, and overhaul Radio Transmitter T-195/GRC-19. Maintenance at general support level includes all the techniques outlined for direct support maintenance. Troubleshooting techniques are located in paragraphs 2-1 through 2-12. Testing techniques are located in paragraph 2-7 and testing procedures are located in chapter 5. Repairs and alignment techniques are located in paragraphs 3-1 through 3-16. The tools, material, and test equipment required for direct support and general support are the same (para 3-5).





## CHAPTER 5

### GENERAL SUPPORT TESTING PROCEDURES

#### 5-1. General

a. Testing procedures are prepared for use by General Support Maintenance Shops and Signal Service Organizations responsible for general support maintenance of signal equipment to determine the acceptability of repaired signal equipment. These procedures set forth specific requirements that repaired signal equipment *must* meet before it is returned to the using organization. The testing procedures may also be used as a guide for testing equipment repaired at direct support if the proper tools and test equipment are available. A summary of the performance standards is given in paragraph 6-8.

b. Each test depends on the preceding one for certain operating procedures and, where applicable, for test equipment calibrations. Comply with the instructions preceding each chart before proceeding to the chart. Perform each test in sequence. Do not vary the sequence. For each step, perform all the actions required in the *Test equipment control settings* and *Equipment under test control settings* columns; then perform each specific test procedure and verify it against its performance standard.

#### 5-2. Test Equipment, Tools, Materials, and other Equipment Required

All test equipment, materials, and other equipment required to perform the testing procedures given in this section are listed in the following charts and authorized under TA 11-17, Signal General Support Maintenance Shops, and TA 11-100 (11-17), Allowances of Signal Corps Expendable Supplies for Signal Direct Support Maintenance Shops, Continental United States.

##### a. Test Equipment.

Nomenclature	Federal stock No.	Technical manual
Audio Oscillator TS-382(*)/U <sup>a</sup> .	6625-192-5094 TM	11-6625-261-12
Oscilloscope AN/USM-24C <sup>b</sup> .	6625-668-9460 TM	11-5103A

Nomenclature	Federal stock No.	Technical manual
Stop watch	6625-765-4321	None
RF Wattmeter TS-118 AP.	6625-237-8204	TM 11-1036
RF ammeter, 0-5*	6625-144-0090	None

<sup>a</sup> Indicates Audio Oscillator TS-382/U, TS-382B/U, TS-382D/U, TS-382E/U, and TS-382F/U.  
<sup>b</sup> Oscilloscope AN/USM-50 may be substituted for Oscilloscope AN/USM-24C.

##### b. Materials.

Material	Federal stock No.
RF Cable RG-8/U, 3 ft Wire, hookup, insulated (5 ft)	6145-161-0887

##### c. Other Equipment.

Equipment	Federal stock No.	Technical manual
Headset HS-30-U	5965-164-7259	None
Handset H-33/PT	5965-164-9947	None
Alligator clip (p/o TE-113).		None
Power Supply PP-1104A/G.	6130-542-6385	TM 11-5126
Cable Assembly CX-2583/U.	5995-636-4580	None
Connectors UG-21C/U, 2 ea.	5820-502-1242	None
Radio Receiver R-390/URR.	5935-503-6275	TM 11-5820-357-10 TM 11-5820-357-20

#### 5-3. Special Requirements

RF Wattmeter TS-118/AP is not designed for use at the frequencies generated by Radio Transmitter T-195/GRC-19. Before using the dummy load therefore, it is necessary that the meter and meter shunt be removed from the wattmeter. In order that the dummy load may be connected to the transmitter and the power dissipation measured, a special test cable must be fabricated using RF Cable RG-8/U with an 0- to 5-ampere RF ammeter connected in series with the center conductor, and the ends terminated with Connectors UG-21C/U. Fabricate the test cable as shown in figure 5-1.

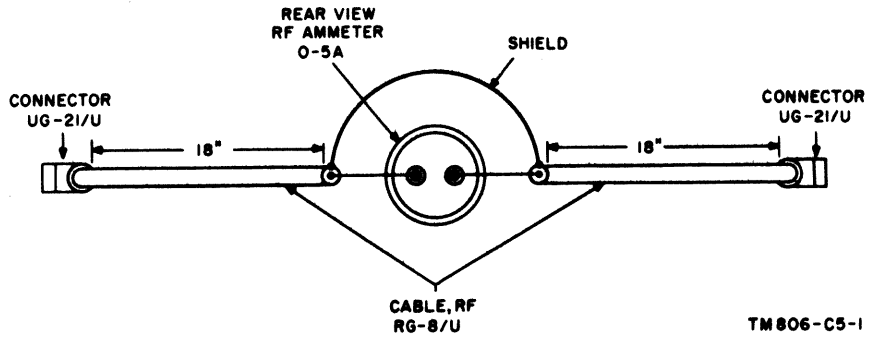

Figure 5-1. Special test cable construction details.

#### 5-4. Modification Work Orders

No modification work orders pertinent to Radio Transmitter T-195/GRC-19 were in effect at time of preparation of these changes. Modifica-

tion work orders pertaining to this equipment which may have been published subsequently will be found in DA PAM 310-4.



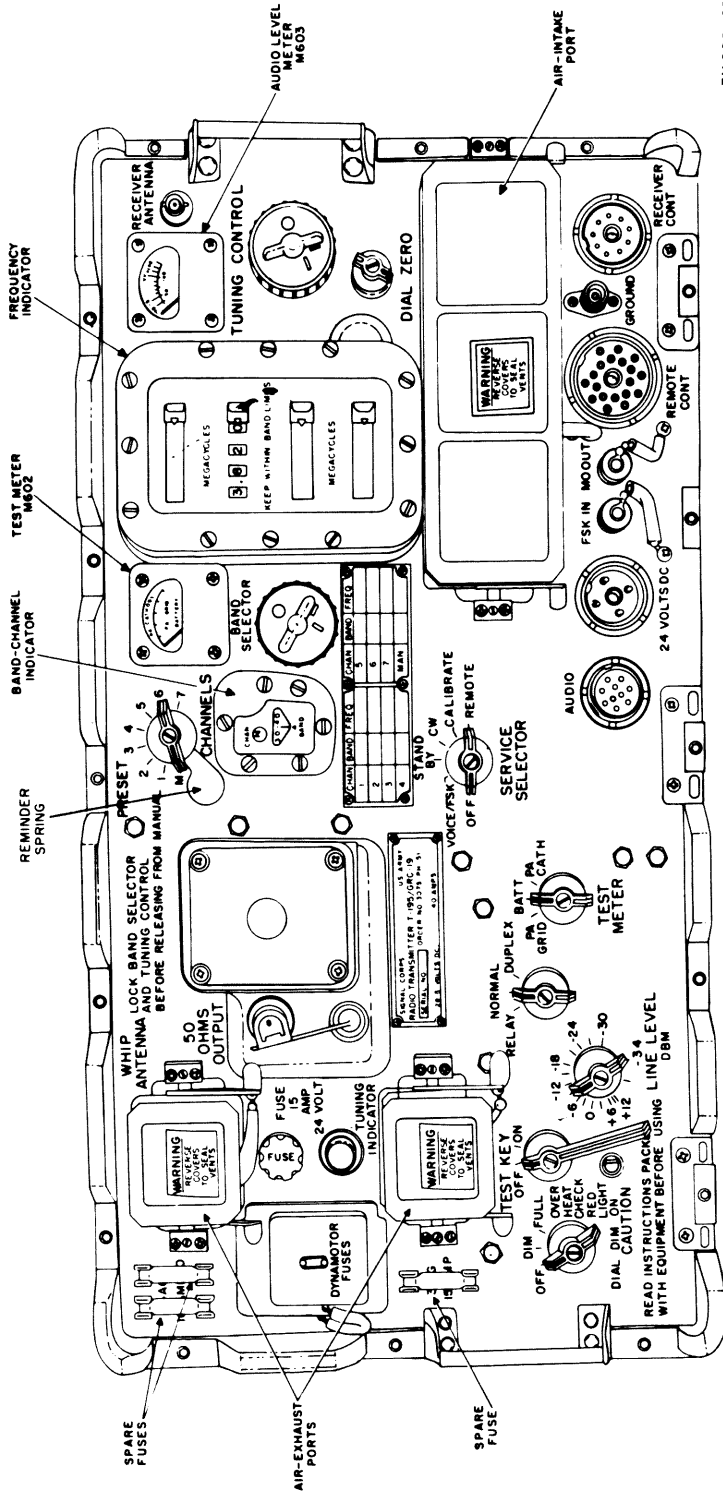

Figure 5-2. Physical tests and inspection.

TM 806-C5-2

**5-6. Modulation Test**

(fig. 5-4)

**a. Test Equipment and Materials.**

- AN/USM-24C
- TS-382(\*)/U
- TS-118(\*)/AP
- H-33/PT
- Aligator Clip (p/o TE-113)
- CX-2588/U

Insulated hook-up wire, 5 feet  
Special test cable

**b. Test Connections and Conditions. Connect the equipment as shown in figure 5-4. Turn on test equipment.**

**c. Procedure.**

Step No.	Test equipment control settings	Equipment under test control settings	Test procedure	Performance standard
1	<p>TS-382(*)/U:</p> <p>FREQ MULT: X 10 OUTPUT</p> <p>MULTIPLIER: X.1 (ATTENUATOR on A model)</p> <p>TUNING: 100</p> <p>AN/USM-24C:</p> <p>V MULTIPLIER: 30</p> <p>CAL: OFF</p> <p>SWEEP DELAY: OUT</p> <p>SWEEP RANGE: 500-5K</p> <p>SYNC: INT</p> <p>TRIGGER PPS: OFF</p> <p>MARKER milli-second:</p> <p>BEAM MOD</p> <p>SWEEP STABILITY: 1/2 revolution clockwise.</p>	<p>SERVICE SELECTOR: STANDBY</p> <p>PRESET CHANNELS: 4</p> <p>RELAY-NORMAL-DUPLEX: RELAY</p> <p>LINE LEVEL: -34</p> <p>DIAL DIM: DIM</p>	<p>Adjust FOCUS, BEAM, H POS, and H GAIN controls on AN/USM-24C for a sharp, clear trace over at least five large divisions of the scope face.</p> <p>Turn the transmitter SERVICE SELECTOR switch to CW and operate the TEST KEY to ON. Using the V GAIN and V POS controls on the oscilloscope, set the carrier pattern to cover 10 small vertical divisions as shown in A, figure 126.4.</p> <p>Turn the SERVICE SELECTOR switch to VOICE FSK and adjust the audio oscillator OUTPUT CONTROL until the output meter indicates .15.</p> <p>Operate the TEST KEY on the radio transmitter to ON and observe the pattern on the oscilloscope. Adjust the FINE SWEEP until approximately 2 cycles of the modulation envelope appear on the screen as shown in B, figure 126.4.</p> <p>Set the SERVICE SELECTOR switch to STANDBY and proceed to the next test.</p>	<p>None.</p> <p>None.</p> <p>None.</p> <p>None.</p> <p>The modulation envelope must cover 4 small divisions at minimum points and 16 at the maximum points.</p>

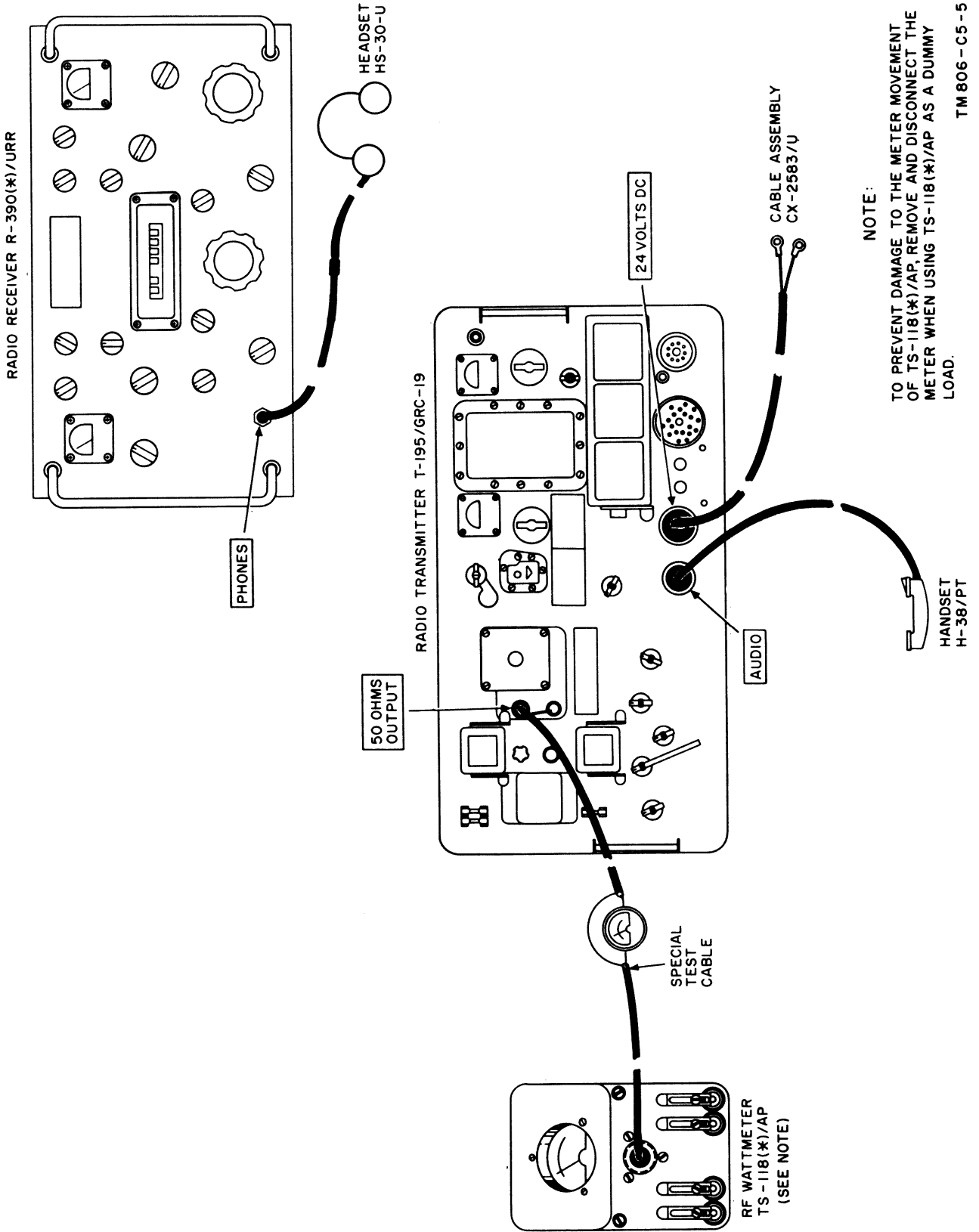

Figure 5-5. Frequency comparison and operation tests.

**5-7. Frequency Comparison and Operation Tests**  
(fig. 5-5)

*a. Test Equipment and Materials.*

- R-390/UUR
- TS-118(\*)/AP
- HS-30-U
- Special test cable
- T-33/PT
- CX-2583/U

*b. Test Connections and Conditions.* Connect the equipment as shown in figure 5-5. Set both R-390/UUR and T-195/GRC-19 to STANDBY for warmup before proceeding with the tests.

*c. Procedure.*

Step No.	Test equipment control settings	Equipment under test control settings	Test procedure	Performance standard
1	R-390/UUR: BFO: ON  FUNCTION: AGC LOCAL GAIN: 5 AGC: MED  RF GAIN: 7  BFO PITCH: set to 0 BANDWIDTH: 8KC  AUDIO RESPONSE: WIDE  LIMITER: OFF	DIAL DIM: FULL SERVICE SELECTOR: CW TEST METER: PA CATHODE  RELAY-NORMAL-DUPLEX: NORMAL  PRESET CHANNELS: M	Set the receiver controls for operation on approximately the same frequency as observed on the frequency indicator dial of the transmitter.   Operate the TEST KEY to the ON position and allow the T-195/GRC-19 to complete its tuning cycle before releasing the TEST KEY, tune the receiver to the frequency as indicated by the zero beat condition heard from Headset HS-30/U.  Repeat <i>a</i> and <i>b</i> for each of the remaining preset channels. Make sure that the receiver is calibrated before making the frequency comparison at each of the preset channel frequencies.  Using the services of an assistant to operate the transmitter, listen to the signal received by the R-390/UUR.  Turn off all equipment.	None.           None.           The frequency indicated should be $\pm .5$ KC on both receiver and transmitter.           Speech should be clear and distinct. No extraneous noises should be heard.    None.
2	Same as at end of step No. 1, except:  BFO: OFF	Same as at end of step No. 1, except:  SERVICE SELECTOR: VOICE/FSK		

**5-8. Summary of Performance Standards**

Personnel may find it convenient to arrange the checklist in a manner similar to that shown below:

---

RADIO TRANSMITTER T-195/GRC-19

---

	Test Data	Performance Standard
<b>1. TUNING CAPABILITY AND POWER OUTPUT</b>		
a. Time delay for high voltage	-----	30-50 seconds
b. Tuning capability	-----	Within PA GRID portion of TEST METER scale
c. Power output	-----	1.4 amp rf minimum
<b>2. MODULATION TEST</b>		
a. Per cent modulation	-----	80% ± 5%
<b>3. FREQUENCY AND LISTENING TESTS</b>		
a. Frequency comparison	-----	±.5 kc
b. Listening Test	-----	Signals clear, distinct, good quality.

---



## CHAPTER 6

### DEPOT OVERHAUL STANDARDS

#### 6-1. Applicability of Depot Overhaul Standards

The tests outlined in this chapter are designed to measure the performance capability of a repaired transmitter. Transmitters that are to be returned to stock should meet the standards given in these tests.

#### 6-2. Applicable References

*a. Repair Standards.* Applicable procedures of the depots performing these tests and the general standards for repaired electronic equipment given in TB SIG 355-1, TB SIG 355-2, and TB SIG 355-3 form a part of the requirements for testing this equipment.

*b. Technical Publications.* The following technical publications are applicable to the equipment (refer to DA Pam 310-4 for TM changes in force):

*b. Technical Publications.*

Title	Number
Depot Inspection Standard for Repaired Signal Equipment	TB SIG 355-1
Depot Inspection Standard for Refinishing Repaired Signal Equipment	TB SIG 355-2
Depot Inspection Standard for Moisture and Fungus Resistant Treatment	TB SIG 355-3
Military Specification for Transmitter, Radio T-195( ) / GRC-19	MIL-T-10475 B

*c. Modification Work Orders.* Perform all Modification Work Orders (MWOs) applicable to this equipment before making the tests specified. DA Pam 310-7 lists all applicable MWOs.

#### 6-3. Additional Equipment Required

In addition to the test equipment listed in the Maintenance Allocation Chart, the following equipment is required:

Item	Federal Stock Number	Quantity
Generator, Signal SG-71/FCC	6625-669-0255	1
Generator, Signal AN/GRM-50	6625-868-8353	1
Oscilloscope, AN/USM-140A	6625-987-6603	1
Spectrum Analyzer, TS-723/U	6625-668-9418	1
Test Set, RF Power TS-118/AP	6625-749-5399	1
Voltmeter, Electronic ME-30(*)/U	6625-669-0742	1
Multimeter, ME-26(*)/U	6625-646-9409	1
Frequency Meter AN/URM-79	6625-668-9749	1
Multimeter, AN/URM-105	6625-581-2036	1
RF Ammeter, 0-5 amperes	6625-144-0090	1
Headset, H-216/U	5965-892-3353	1
Stopwatch	6645-679-8217	1
Shunt, Instrument Multirange MX-1471/U (P/O AN/URM-105)	6625-578-5408	1
Resistor, Composition 600 ohms ±10 ohms, 2 watt	5905-250-8292	1
Power Supply, 28.5 VDC		1
Remote Control, CS-822( ) / GRC-19		1

#### 6-4. General Test Requirements

When a repaired transmitter is being tested, perform tests in sequence and comply with preparatory instructions.

*a. Scope of Tests.* The following tests will be performed to determine the acceptability of repaired transmitters for return to stock:

- (1) Physical test and inspection.
- (2) Electrical circuit tests.

*b. Initial Conditions.*

- (1) Perform all tests at room temperature.
- (2) Properly ground all equipment before making power connections.
- (3) Connect P801 to J620 and P601 to J101.
- (4) Connect a jumper between the FSK IN and MO OUT jacks on the front panel.

(5) Connect transmitter to a  $28.5 \pm 0.5$  vdc, 45 ampere power supply capable of a maximum surge of 250 amperes for 0.5 seconds with an average drop of less than 14 volts.

(6) Allow transmitter to warm up for at least 10 minutes before performing any tests.

**6-5. Physical Test and Inspection**

The equipment shall meet the mechanical and visual requirements specified in Repair Standards TB SIG 355-1, -2, and -3.

**6-6. Electrical Circuits Tests**

The following tests are designed to measure the performance capability of the transmitter.

a. *Frequency and Power Output Tests* (fig. 6-1).

(1) Set transmitter controls as follows:

(a) SERVICE SELECTOR switch to CW.

(b) PRESET CHANNELS switch to M (1.5 MHz).

(2) Key the transmitter. Measure and record the tune-up time. Tune-up time is defined as the time interval between closing the key after the power supplies have started, and the appearance of a steady indication on the RF ammeter. Channel tune-up time shall be within the limits specified in the chart below.

(3) Key the transmitter, then measure and record the input power current drain. The maximum input current shall be 37 amperes. Unkey the transmitter.

(4) Key the transmitter, then measure and record the RF power output. The RF power output is measured as:  $I^2 \times 50$  where I is the RF current reading in amperes on the RF ammeter and 50 is the impedance of the dummy load. The minimum allowable power output shall be within the limits specified in the chart below. Unkey the transmitter.

(5) Key the transmitter and record the output frequency on the AN/URM-79. The output frequency shall be within plus or minus 0.1 percent of the indicated frequency. Unkey the transmitter.

(6) Repeat steps (2) through (5) for channels 1 through 7.

(7) Set transmitter controls as follows:

(a) PRESET CHANNELS switch to Channel 1.

(b) BAND SELECTOR to 2.4-3.0 MHz.

(c) TEST METER switch to PA CATH.

(8) Key the transmitter. When the tuning indicator lights, read PA CATHODE-PA GRID-BATTERY meter for an indication within the white area of the PA CATHODE section.

(9) Repeat step (8) for Channel 4 in the 1.7-2.0 MHz band.

Test Channel	M	1	2	3	4	5	6	7
Maximum Allowable	) 35	) 35	) 50	) 25	) 15	) 10	) 10	) 10
Tune-up Time in Sec's	)	)	)	)	)	)	)	)
Minimum Allowable	) 100w	) 100w	) 100w	) 100w	) 100w	) 100w	) 90w	) 80w
Power Output	)	)	)	)	)	)	)	)

b. *Audio Frequency Distortion Test* (fig. 6-3).

(1) Using the special demodulating circuit, couple Spectrum Analyzer TS-723/U to the cable connecting the 50 OHMS OUTPUT jack to TS-118/AP.

(2) Set transmitter controls as follows:

(a) SERVICE SELECTOR switch to FSK/VOICE.

(b) PRESET CHANNELS switch to Channel 4 (7 MHz).

(c) RELAY-NORMAL-DUPLEX switch to NORMAL.

(3) Apply a 1000-Hz audio signal to the AUDIO jack. Key the transmitter and adjust the output level control of the signal generator for an 80-percent modulation of the 7 MHz carrier as observed on the oscilloscope. Measure the percentage of harmonic distortion on the TS-723/U. The distortion *must not exceed* 12 percent.

c. *Audio Frequency Response Test.* (fig. 6-3).

(1) Using the special demodulating circuit, couple Spectrum Analyzer TS-723/U to cable connecting the 50 OHMS OUTPUT jack to TS-118/AP.

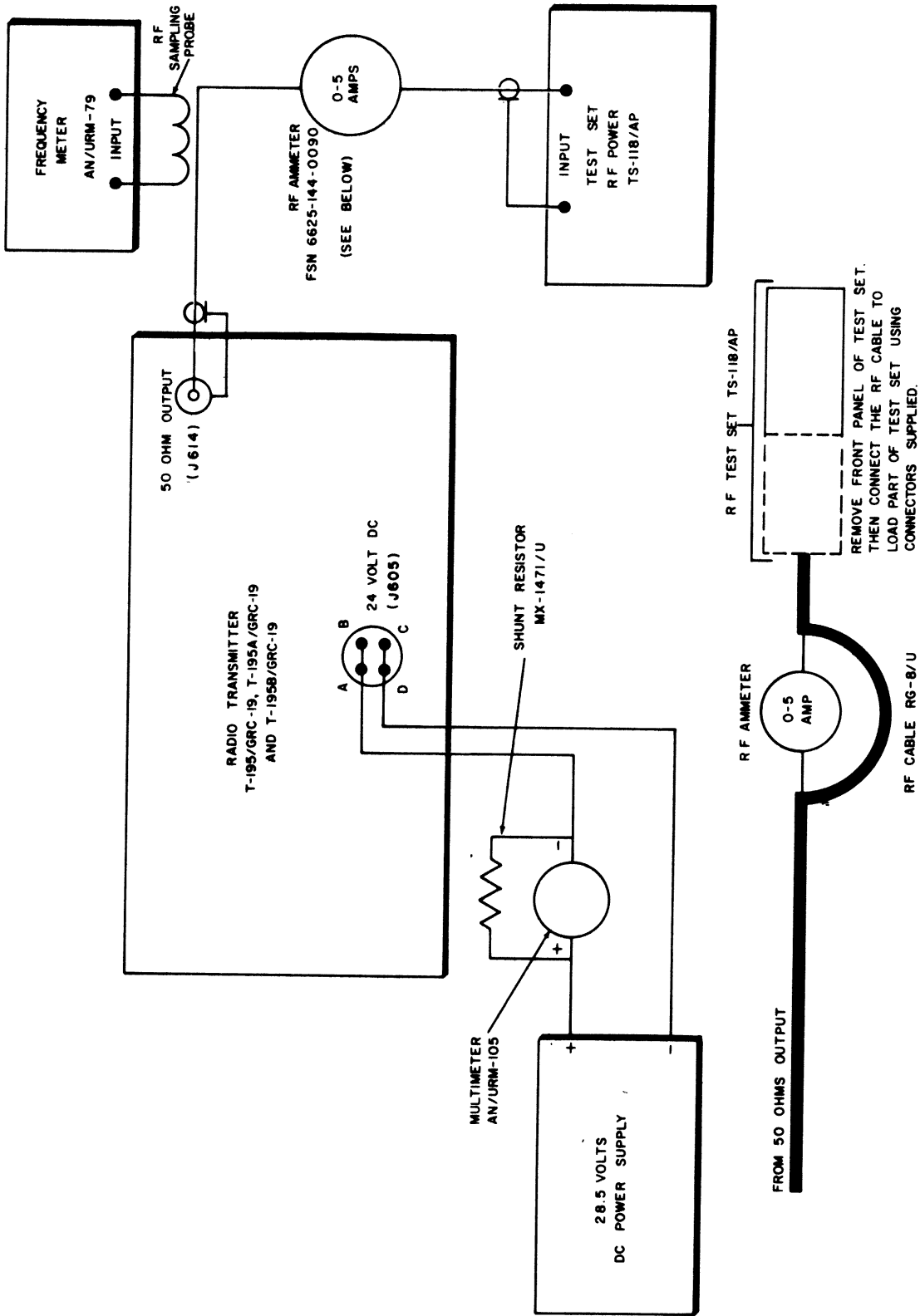

TM5820-335-35-40

Figure 6-1. Frequency and output power tests.

(2) Set transmitter controls as follows:

(a) SERVICE SELECTOR switch to FSK/VOICE.

(b) PRESET CHANNELS switch to Channel 4 (7 MHz).

(c) RELAY-NORMAL-DUPLEX switch to NORMAL.

(3) Apply a 1000-Mz audio signal to the AUDIO jack. Key the transmitter and adjust the output level control of the audio oscillator for an 80-percent modulation of the 7 MHz carrier as observed on the oscilloscope. Record the audio level input voltage reading on the ME-30(\*)/U.

(4) With the transmitter keyed, record the audio level dB reading on the TS-723/U. This reading is the 1000-Hz reference level. Unkey the transmitter.

(5) Change the output frequency of the signal generator to 300 Hz. Key the transmitter and adjust the output level control of the signal generator for the same reading on the ME-30(\*)/U as recorded in step (3).

(6) Record the audio level reading in dB on the TS-723/U. The dB level reading must be between +0.5 and -3 dB of the dB level recorded in step (4). Unkey the transmitter.

(7) Repeat steps (5) and (6) with the signal generator output frequency set at 3.5 kHz. The dB output level of the TS-723/U must be between +0.5 and -3 dB of that recorded in step (4).

*d. Audio Frequency Noise Test (fig. 6-3).*

(1) Set the transmitter controls as follows:

(a) SERVICE SELECTOR switch to FSK/VOICE.

(b) PRESET CHANNELS switch to Channel 4 (7 MHz).

(c) RELAY-NORMAL-DUPLEX switch to RELAY.

(2) Apply a 1000-Hz audio signal to the AUDIO jack. Key the transmitter and adjust the output level control of the signal generator for an 80-percent modulation of the 7 MHz carrier as observed on the oscilloscope. Record the detected audio voltage level appearing on the TS-723/U. This level is used as a 0db reference level. Unkey the transmitter.

(3) Remove the signal generator connection from the AUDIO jack. Key the transmitter and record the detected audio voltage level appearing on the TS-723/U. This level shall *not* be less than 38 db below the level recorded in step (2). Unkey the transmitter.

(4) Position the SERVICE SELECTOR switch to CW. Key the transmitter and record

the detected audio voltage level appearing on the TS-723/U. This level shall not be less than 38 dB below the level recorded in step (2). Unkey the transmitter.

*e. Modulation Capability Test (600-ohm line input) (fig. 6-2).*

(1) Set transmitter controls as follows:

(a) SERVICE SELECTOR switch to FSK/VOICE.

(b) PRESET CHANNELS switch to Channel 4 (7 MHz).

(c) RELAY-NORMAL-DUPLEX switch to RELAY.

(d) LINE LEVEL control to extreme counterclockwise position.

(e) MODULATOR GAIN control to extreme counterclockwise position.

(f) CLIPPING control to extreme counterclockwise position.

(2) Apply a 1000-Hz audio signal to the AUDIO jack.

(3) Key the transmitter. Adjust the output level of the signal generator for 80 percent modulation of the 7 MHz carrier as observed on the oscilloscope. Record the audio output level reading of the ME-30(\*)/U. The required audio input to the transmitter for 80 percent modulation shall *not be more* than 12 millivolts. Record the dc input power current drain. The current drain shall *not be more* than 42 amperes. Record the reading on the front panel VU meter. The reading shall be between minus 1 and minus 3 VU meter units. Unkey the transmitter.

*f. Sidetone Output Test (fig. 6-4).*

(1) Set transmitter controls as follows:

(a) SERVICE SELECTOR switch to FSK/VOICE.

(b) PRESET CHANNELS switch to Channel 4 (7 MHz).

(c) RELAY-NORMAL-DUPLEX to NORMAL.

(2) Apply a 1000 Hz audio signal to the AUDIO jack. Adjust the output level control for a 0.14 volt rms reading on the ME-30(\*)/U.

(3) Key the transmitter and record the audio level reading on the TS-723/U. Unkey the transmitter.

(4) Remove the audio signal and set the SERVICE SELECTOR switch to CW. Key the transmitter and record the audio level reading on the TS-723/U. Unkey the transmitter.

(5) The audio levels recorded in steps (3), (4), and (5) shall *not be less* than 10 dB referred to 1 milliwatt (dBm).

*g. Remote Control Operation Test (fig. 6-5).*

(1) Set transmitter controls as follows:

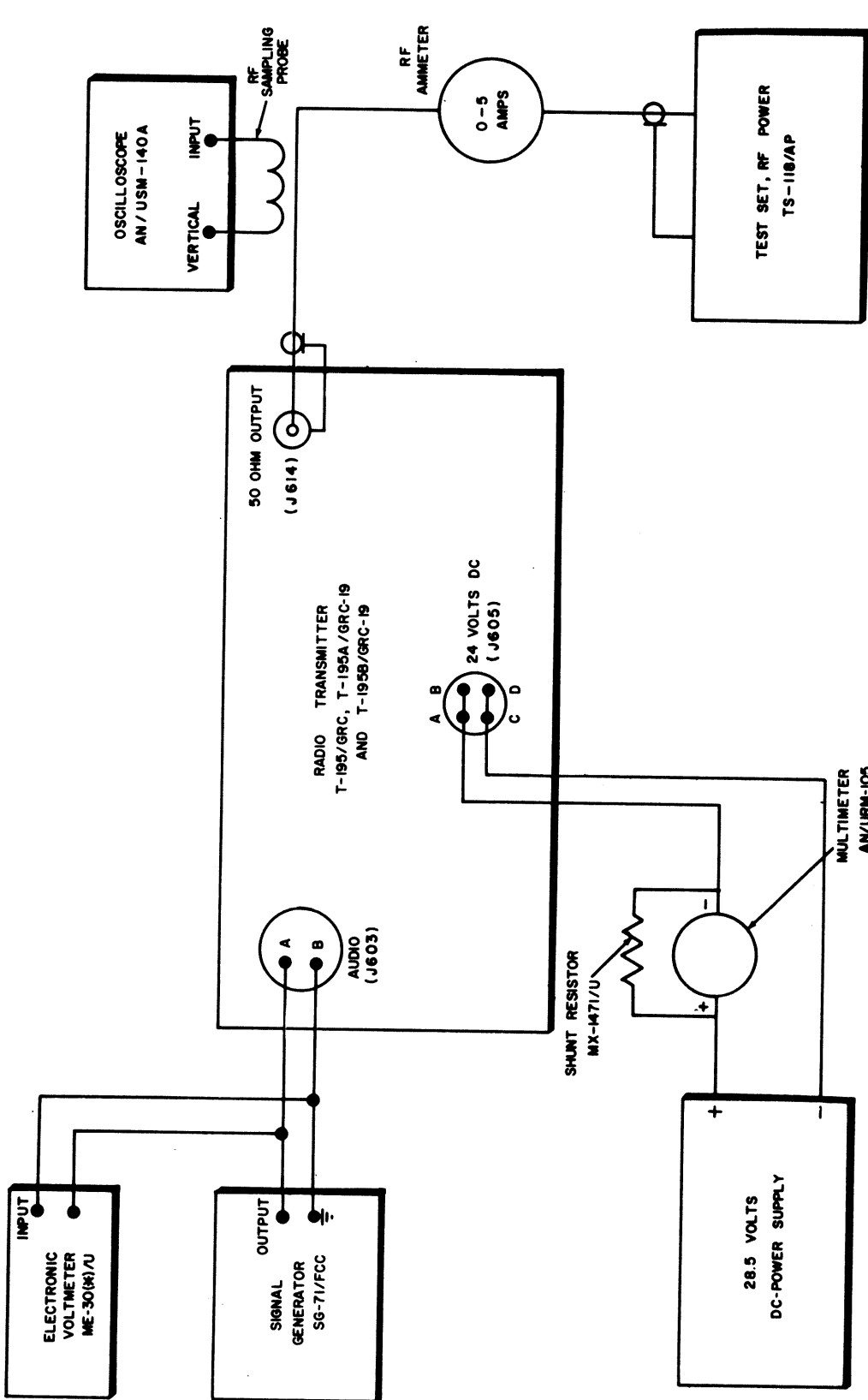

TM5820-335-35-41

Figure 6-2. Modulation capability.

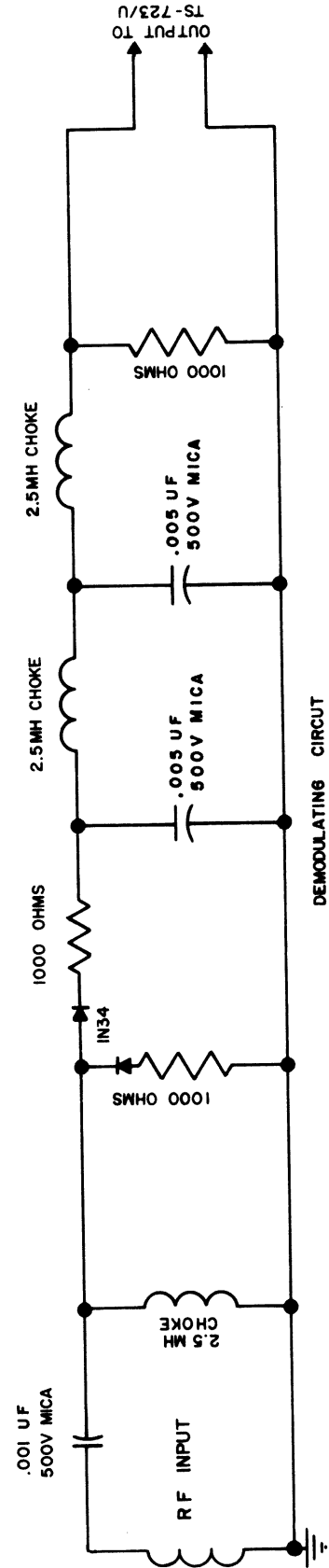
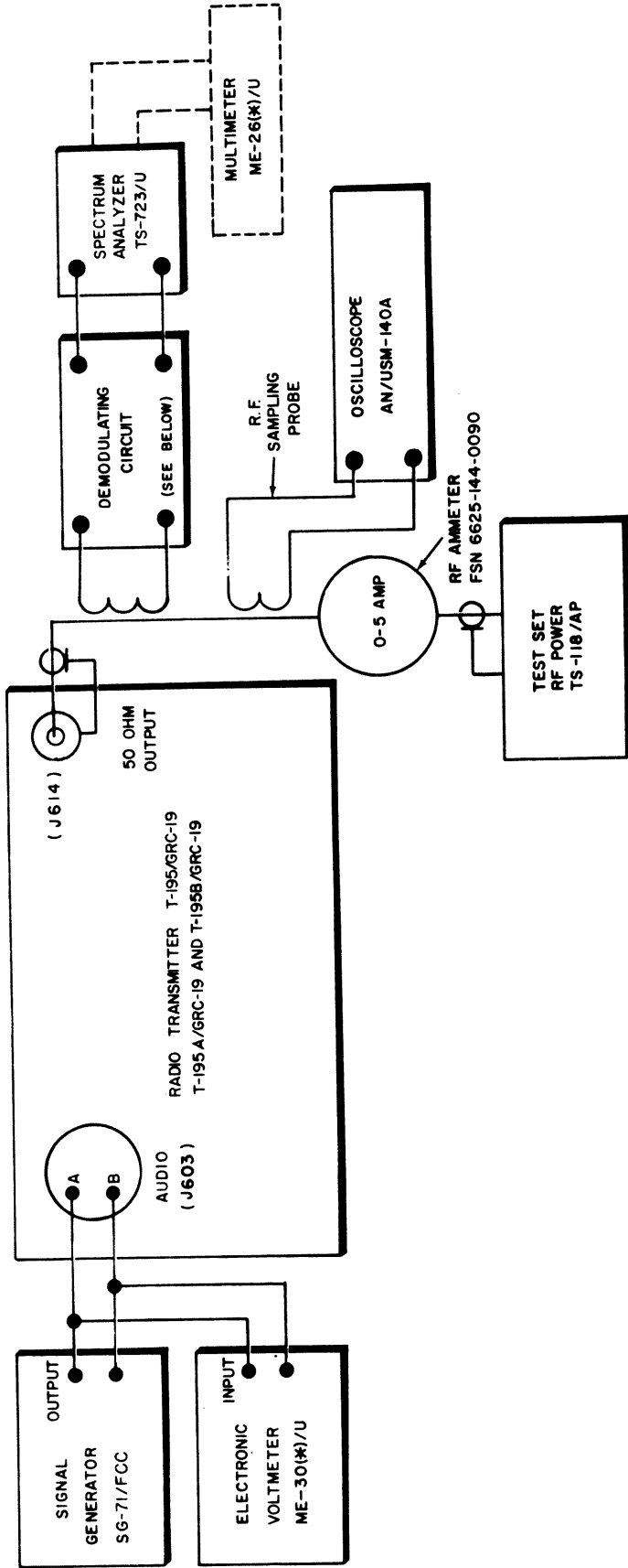
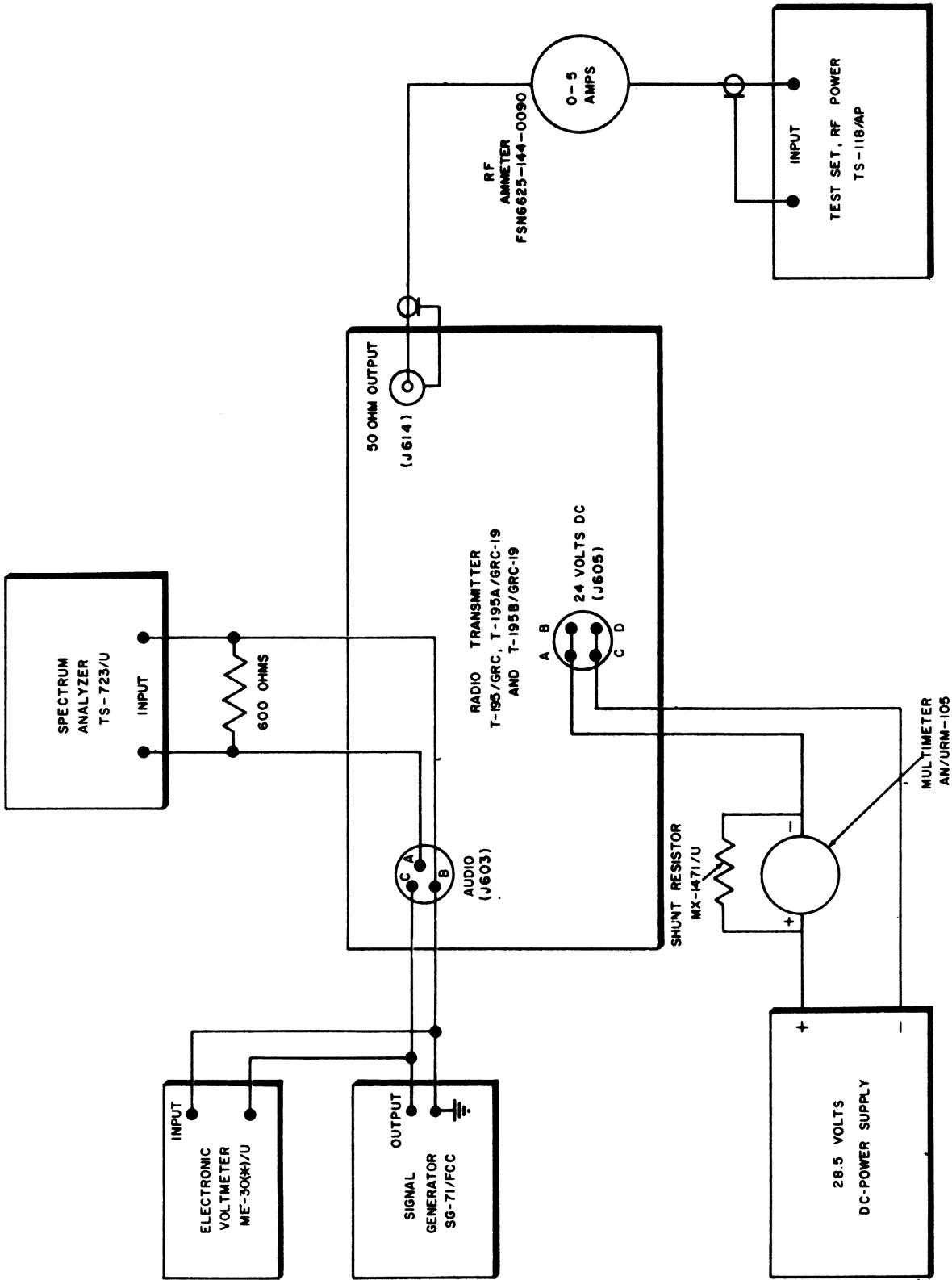

Figure 6-3. Audio frequency response, distortion, and noise test.



TM5820-335-35-43

Figure 6-4. Sidetone output test.

(a) SERVICE SELECTOR switch to CALIBRATE.

(b) PRESET CHANNELS switch to M.

(2) Connect Remote Transmitter Control C-822( )/GRC-19 to the REMOTE CONT jack.

(3) With the remote Service SELECTOR in STANDBY, turn the transmitter SERVICE SELECTOR to OFF.

(4) One at a time, select Channels 1 through 7 at the remote station and check for proper auto-tune operation. Also check that the local PRESET CHANNELS switch has no control.

(5) When Channel 7 has been selected in step (4), key the transmitter remotely and check to see that remote TUNING INDICATOR lamp operates simultaneously with the transmitter TUNING INDICATOR lamp. The transmitter shall give full RF power output with normal direct current (dc) input.

(6) Set the remote SERVICE SELECTOR switch to FSK/VOICE. Check modulation capability from the remote control point by talking into the microphone and noting any increase in antenna current. Check for sidetone output at the remote control point by connecting headset H-216/U to pins F and B of the AUDIO jack.

(7) Set transmitter PRESET CHANNELS to Channel M and the transmitter SERVICE SELECTOR to CALIBRATE. Note that auto-tune system sets up on Channel M.

*h. FSK Operation Test (fig. 6-6).*

(1) Set transmitter and remote CS-822( )/GRC-19 controls as follows:

(a) SERVICE SELECTOR switch to FSK/VOICE.

(b) PRESET CHANNELS switch to Channel 5 (12 MHz).

(2) Disconnect jumper between MO OUT and FSK IN.

(3) Connect Signal Generator AN/USM-50 to FSK IN jack.

(4) Adjust signal generator for a RF output frequency of 3 MHz at a level of 3.0 plus or minus 0.25 volts rms.

(5) Key the transmitter and turn TUNING CONTROL slightly to obtain maximum power-amplifier-grid current reading on the PA CATHODE-PA GRID-BATTERY meter. The grid current shall *not be less* than 10 milliamperes.

(6) Measure dc power input and RF power output. The dc current at 28.5 plus or minus 0.5 volts, dc, shall *not be more* than 38 amperes.

The RF power output shall *not be less* than 100 watts. Unkey the transmitter.

*i. Low Voltage Operation Test (fig. 6-7).*

(1) Set the transmitter controls as follows:

(a) SERVICE SELECTOR switch to FSK/VOICE.

(b) PRESET CHANNELS switch to Channel 1 (2.4 MHz).

(2) Reduce input voltage to 25.0 plus or minus 0.5 volts, dc. (Input measured from pin C of REC connector).

(3) Close test key after auto-tune comes to rest and keep closed until automatic tuning cycle is completed.

(5) When Channel 7 has been selected in step (4), key the transmitter remotely and check to see that remote TUNING INDICATOR lamp operates simultaneously with the transmitter TUNING INDICATOR lamp. The transmitter shall give full RF power output with normal direct current (dc) input.

(6) Set the remote SERVICE SELECTOR switch to FSK/VOICE. Check modulation capability from the remote control point by talking into the microphone and noting any increase in antenna current. Check for sidetone output at the remote control point by connecting headset H-216/U to pins F and B of the AUDIO jack.

(7) Set transmitter PRESET CHANNELS to Channel M and the transmitter SERVICE SELECTOR to CALIBRATE. Note that auto-tune system sets up on Channel M.

*j. FSK Operation Test (fig. 6-6).*

(1) Set transmitter and remote CS-822( )/GRC-19 controls as follows:

(a) SERVICE SELECTOR switch to FSK/VOICE.

(b) PRESET CHANNELS switch to Channel 5 (12 MHz).

(2) Disconnect jumper between MO OUT and FSK IN.

(3) Connect Signal Generator AN/USM-50 to FSK IN jack.

(4) Adjust signal generator for a RF output frequency of 3 MHz at a level of 3.0 plus or minus 0.25 volts rms.

(5) Key the transmitter and turn TUNING CONTROL slightly to obtain maximum power-amplifier-grid current reading on the PA CATHODE-PA GRID-BATTERY meter. The grid current shall *not be less* than 10 milliamperes.

(6) Measure dc power input and RF power output. The dc current at 28.5 plus or minus 0.5 volts, dc, shall *not be more* than 38 amperes. The RF power output shall *not be less* than 100 watts. Unkey the transmitter.



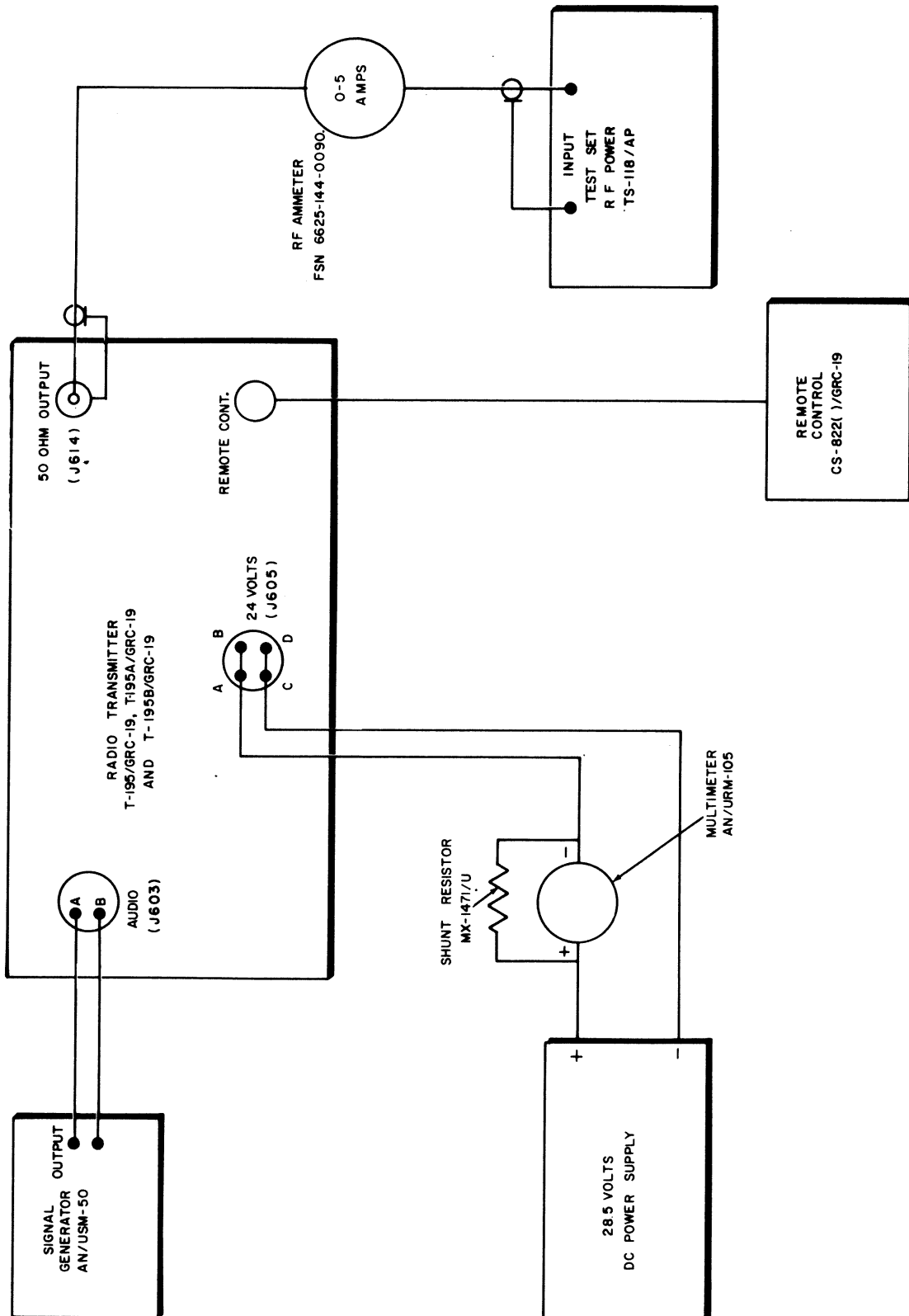

TM5820-335-35-44

Figure 6-5. Remote control operation test.

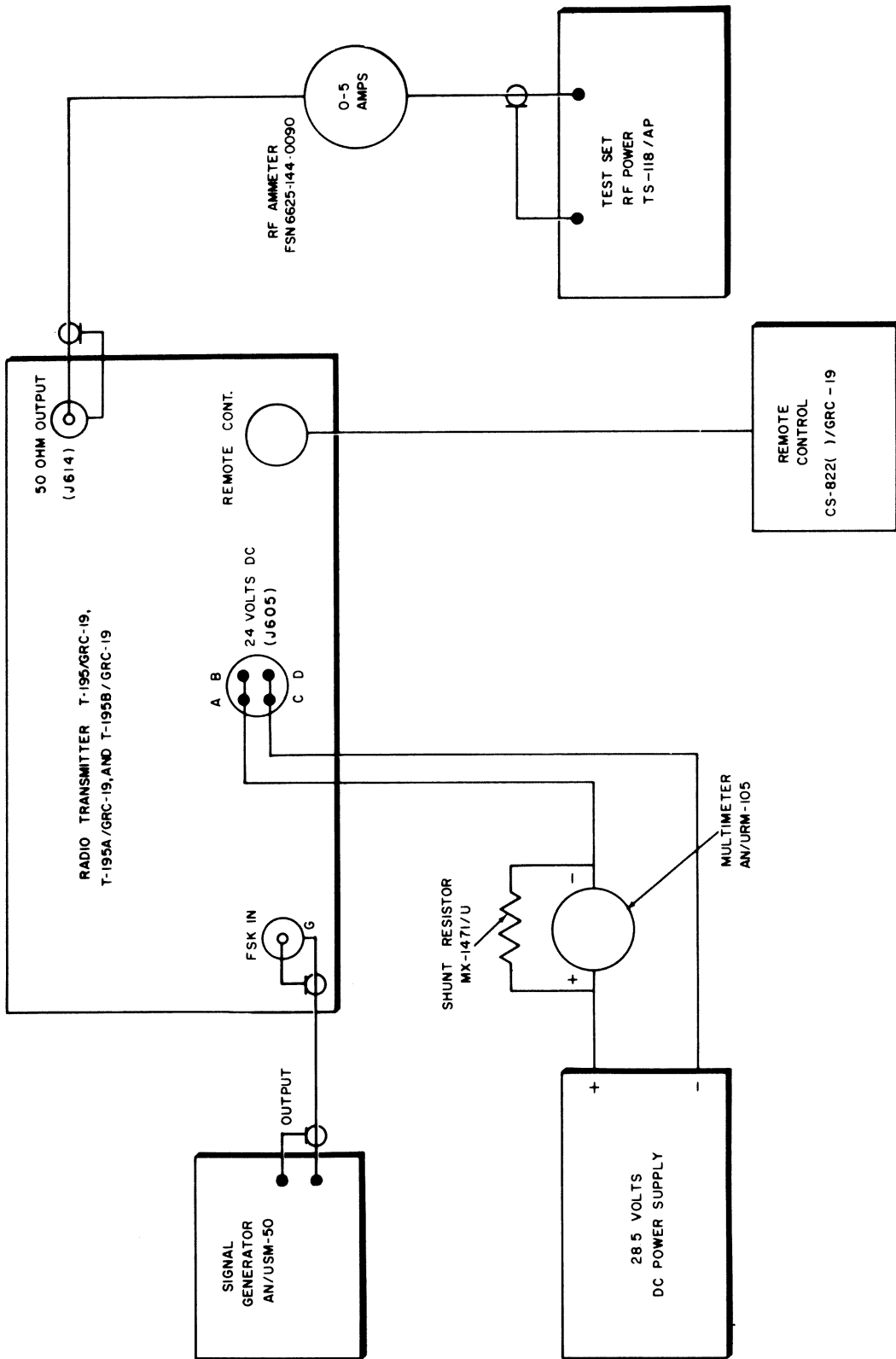

TM5820-335-35-45

Figure 6-6. FSK operation test.

*k. Low Voltage Operation Test* (fig. 6-7).

(1) Set the transmitter controls as follows:

(a) SERVICE SELECTOR switch to FSK/VOICE.

(b) PRESET CHANNELS switch to Channel 1 (2.4 MHz).

(2) Reduce input voltage to 25.0 plus or minus 0.5 volts, dc.

(3) Close test key after auto-tune comes to rest and keep closed until automatic tuning cycle is completed.

(4) Measure the RF power output. The RF power output shall *not be less* than 70 watts. Unkey the transmitter.

(5) Reduce input voltage to 22.5 plus or minus 0.5 volts, dc.

(6) Measure the dc power input and check modulation capability by talking into the microphone and noting any change in the antenna current. The dc input current shall *not be more* than 32 amperes. Unkey the transmitter.

(7) Increase input voltage to the normal value of 28.5 volts, dc, and set SERVICE SELECTOR switch to the CW position.

(8) Withdraw the chassis to check the operation of interlock, S-611. The interlock must operate before the chassis is withdrawn more than one inch.

**6-7. Summary of Test Data**

*a. Frequency and Power Output.*

Test Channel	M	1	2	3	4	5	6	7
Maximum Allowable	)	35	35	50	25	15	10	10
Tune-up Time in Sec's	)							
Minimum Allowable	)	100w	100w	100w	100w	100w	90w	80w
Power Output	)							

*b. Modulation.* Not more than 12 millivolts for 80 percent modulation.

*c. Microphone Input.* Not more than 0.112 volts for 80 percent modulation.

*d. Frequency Response.* Between + 0.5 and -3 dB at 300 Hz and 3,500 Hz.

*e. Distortion.* Nor more than 12 percent.

*f. Audio Frequency Noise.* Not less than -38 dB.

*g. Series Clipping Operation.* Not more than 110 percent modulation between 200 and 4000 Hz.

*h. Sidetone.* Not less than 10 dB referred to 1 milliwatt.

*i. Remote Control.* All controls shall operate freely and perform correct operation of the transmitter.

*j. FSK Operation.* RF power output not less than 100 watts.

*k. Low Voltage Operation.* With input voltage at 25.0, RF power shall not be less than 70 watts. With input voltage at 22.5, dc input current shall not be less than 32 amperes.

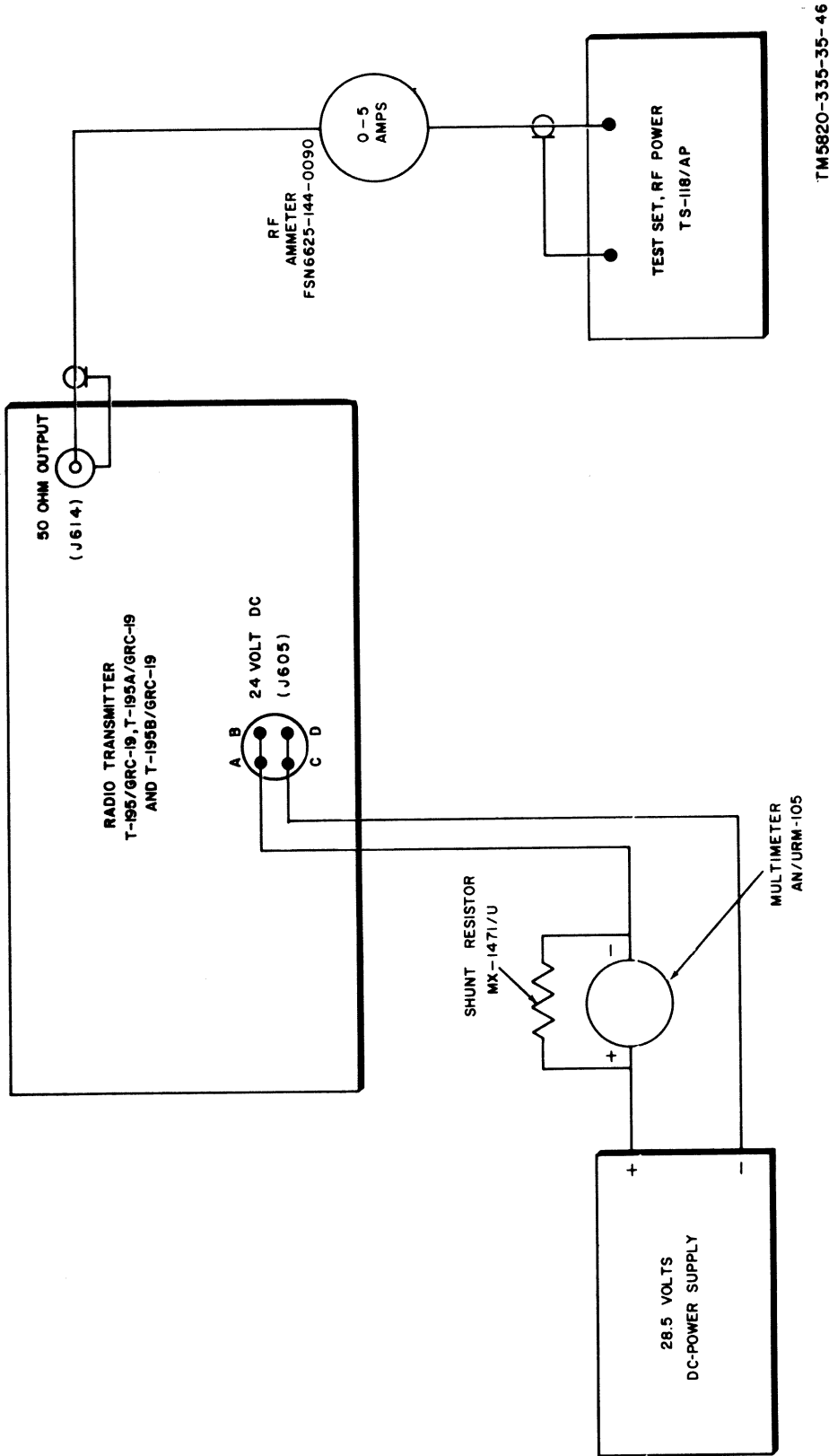

Figure 6-7. Low voltage operation test.

TM5820-335-35-46

## CHAPTER 7

### AUXILIARY EQUIPMENT

#### Section I. TRANSMITTER CONTROL C-822/GRC-19

##### 7-1. Description of Transmitter Control C-822/GRC-19

a. Remote control of Radio Transmitter T-195/GRC-19 at distances up to 75 feet is provided when the transmitter is used in conjunction with Transmitter Control C-822/GRC-19 (fig. 7-1) and Electrical Special Purpose Cable Assembly CX-2585/U (fig. 7-2).

b. Transmitter Control C-822/GRC-19 is a ruggedized, waterproof unit for remote control operation of the transmitter. This remote control unit can turn the transmitter on or off, select the desired type of operation, select one of seven present frequencies, and indicate when transmitter is ready for use. The remote control unit is secured in place by its two mounting ears, using two structural bolts and nuts. The case is sealed watertight by means of a backplate and a gasket. The backplate can be removed by taking out six flathead screws and six lockwashers. Figure 7-3 shows all the parts contained within the remote control unit.

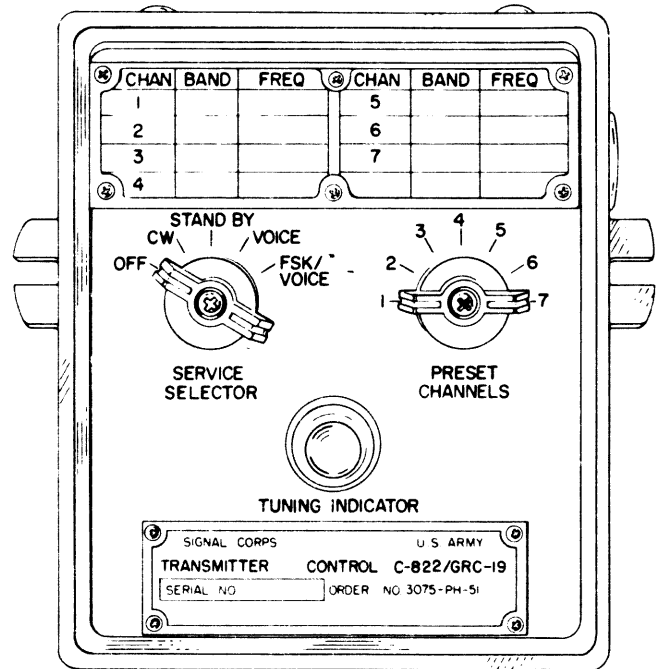

TM806-19

Figure 7-1. Transmitter Control C-822/GRC-19 front panel.

##### 7-2. Description of Electrical Special Purpose Cable Assembly CX-2585/U (fig. 7-2)

Electrical Special Purpose Cable Assembly CX-2585/U connects the remote control unit to the transmitter. The remote control cable consists of nineteen No. 20 conductors in a rubber-covered copper-braid shield, and is 75 feet long. Each end of the cable terminates in a 19-contact, male, 90° angle, waterproof connector, Amphenol type 164-21FS.

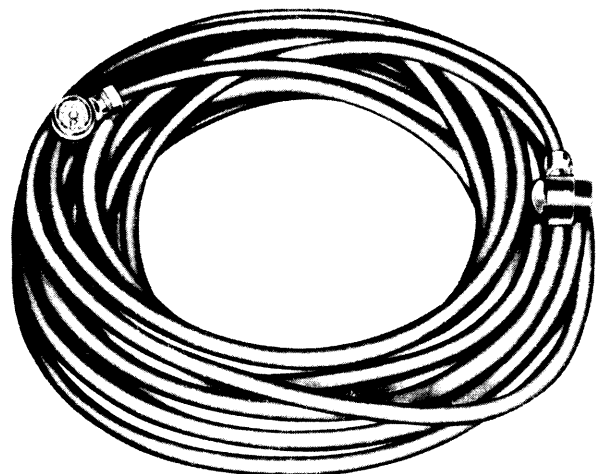

TM806-17

Figure 7-2. Electrical Special Purpose Cable Assembly CX-2585/U.

##### 7-3. Connections

All receptacles for interconnection purposes are located on the two sides of the remote control unit (fig. 7-3). Receptacle J701 provides connection for the remote control cable to Radio Transmitter T-195/GRC-19. Receptacles J702 and

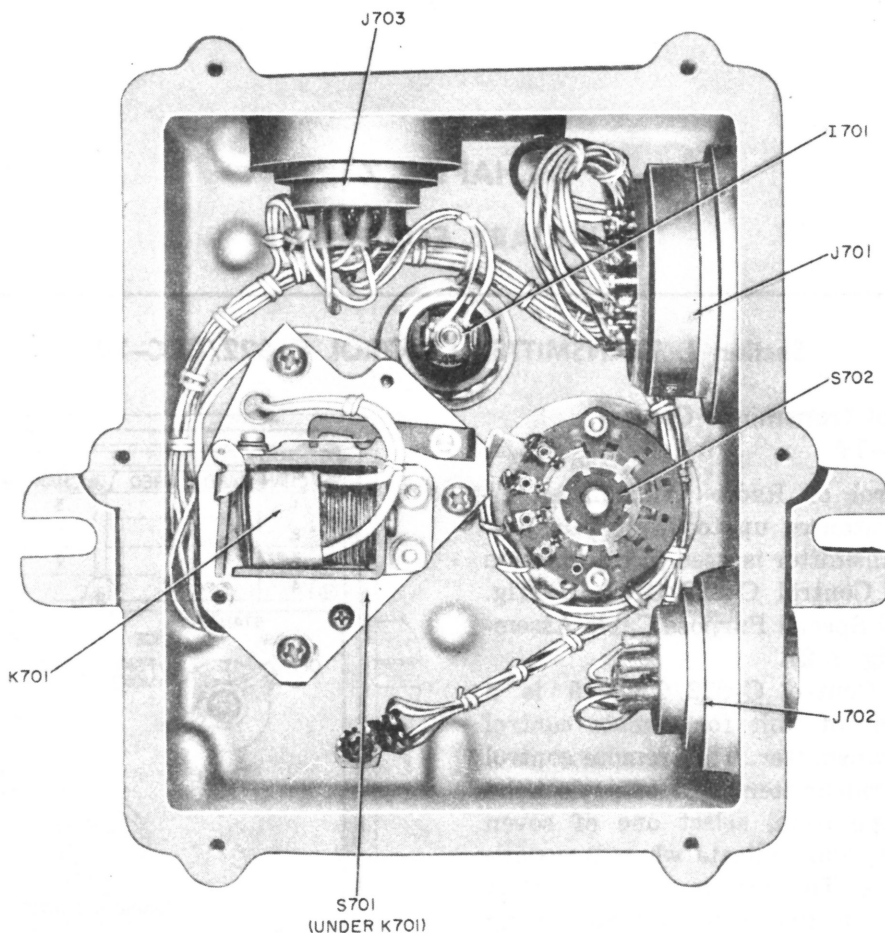

TM 806-16

Figure 7-3. Transmitter Control C-822/GRC-19 with backplate removed.

J703 are similar in function to the AUDIO receptacle of the transmitter, in that these receptacles provide connections to a microphone, key, headset, or to fsk equipment. Refer to figure 7-4 which is a cording diagram of the remote control unit. Receptacle J702 or J703 may be used for connecting the microphone, key handset and/or fsk equipment.

#### 7-4. Operation From Transmitter Control C-822/GRC-19

##### CAUTION

Only use remote control units which have been modified.

All operating controls are located on the front panel (fig. 7-5) of remote control unit. The functions of these controls are the same as for similar controls located in the transmitter. The SERVICE SELECTOR switch, S701, can select the desired type of operation for the transmitter such as cw, voice, or fsk and voice. This switch

also can turn the transmitter off or switch it to standby operation. To operate from a remote point, turn the transmitter SERVICE SELECTOR switch to REMOTE position. The PRESET CHANNELS switch, S702, can select any one of the seven frequencies that had been previously preset at the transmitter. This switch differs from PRESET CHANNELS switch S604 at the transmitter, in that it does not have a manual (or M) position, since there is no provision for manual tuning at the remote control unit. TUNING INDICATOR I 701, like TUNING INDICATOR I 605 at the transmitter, will light whenever the transmitter is tuned.

##### NOTE

The VOICE and FSK/VOICE positions of the SERVICE SELECTOR switch of the remote control unit correspond to the VOICE/FSK position of the SERVICE SELECTOR switch on the transmitter.

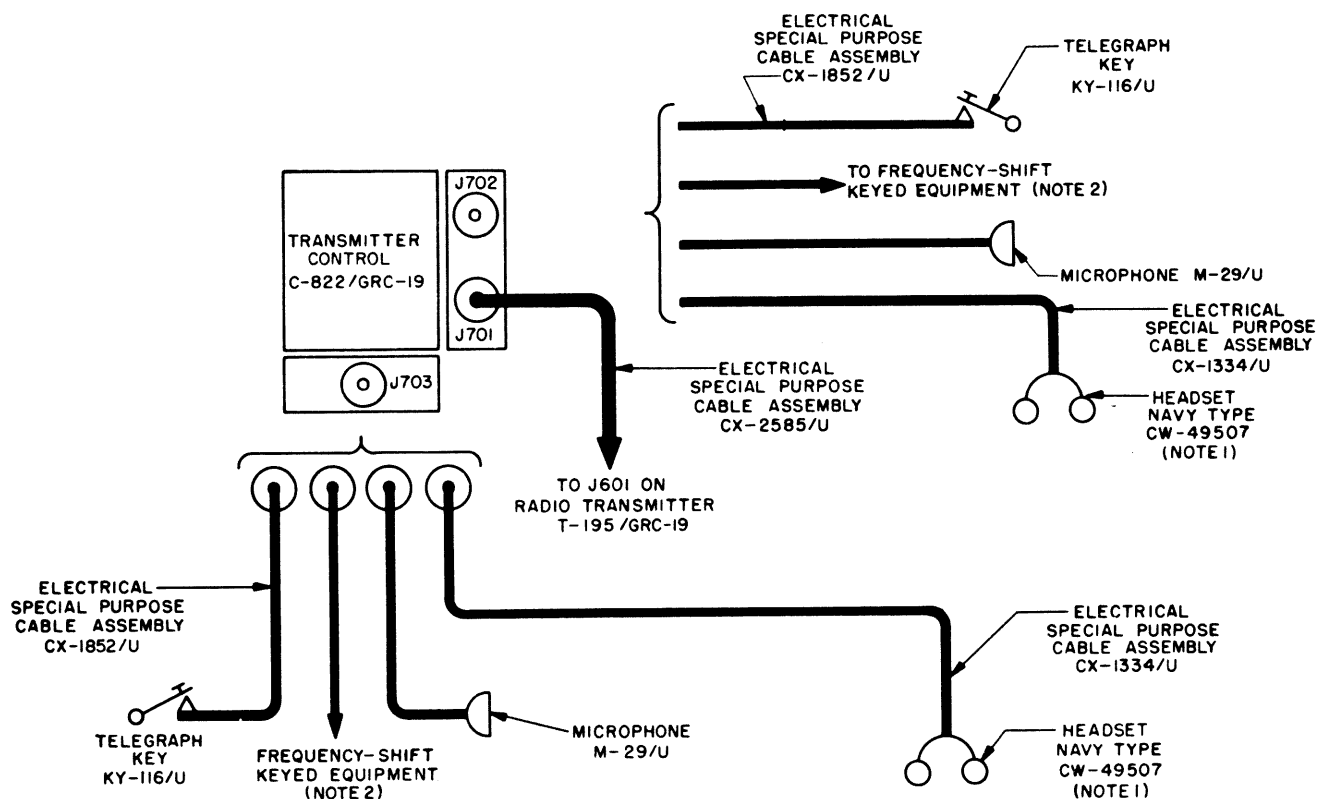

- NOTES:
1. HANDSET H-33/PT CAN BE CONNECTED TO **AUDIO** RECEPTACLE J603.
  2. NOT FURNISHED WITH RADIO SET AN/GRC-19

TM 806 -18

Figure 7-4. Transmitter Control C-822/GRC-19, cording diagram.

### 7-5. Circuit Description (fig. 7-6)

a. Transmitter Control C-822/GRA-19 circuits parallel control circuits contained in Radio Transmitter T-195/GRC-19. A schematic diagram of the remote control unit is given in figure 7-6 and, in addition, REMOTE CONT receptacle J601, mounted on the front panel of the transmitter, is shown.

b. Receptacle J701 connects to J601 through the remote control cable to complete the following circuits.

(1) Terminals R of J701 and J601 connect to provide a common ground for both equipments.

(2) Terminals C of J703 and J702 are connected through J701-B to J601-J, which feeds audio-frequency (af) signals from the microphone to the audio-input circuits of the transmitter.

(3) Terminals A of J703 and J702 connect a set of headphones through J701-J to J601-B which, when the transmitter is in RELAY or NORMAL operation, provides for monitoring of the transmitter signal.

(4) Terminals F of J703 and J702 are connected to J701-D which, in turn, connects to J601-F. This completes a grounding circuit to the coil of the keying relay which keys the transmitter when the microphone switch or key is closed.

(5) Terminal A of J701 connects to J601-K to place the TUNING INDICATOR lamp (1701) in parallel with the indicator lamp in the transmitter.

(6) Terminals K, L, M, and P of J701 connect to terminals A, W, V, and T of J601 to place the PRESENT CHANNELS switch (S702) in parallel with the PRESET CHANNELS switch in the transmitter. This provides for remote control of the transmitter channel selection circuits.

The leads to S702 are disconnected at the transmitter when the transmitter SERVICE SELECTOR switch is moved from its REMOVE position.

(7) SERVICE SELECTOR switch S701 (front) will connect terminal S of J701 and J601 to ground through contacts 5 and 4 when the switch is moved from its OFF position. This will energize the transmitter filament start relay, which will supply operating voltage to the transmitter. Contact 11 of S701 also is grounded, providing a ground to PRESET CHANNELS switch C702.

(8) Contact 8 of S701 is connected to ground through contact 5 when S701 is in the VOICE/FSK position. This completes the voice relay coil circuit in the transmitter, which enables the transmitter audio circuits.

(9) Contact 9 of S701 is grounded through contact 5 in the VOICE/FSK position, which energizes the transmitter fsk relay.

(10) When contact 11 of S701 is connected to ground, the (lv) dynamotor or low-voltage transistor-type power supply in the transmitter is energized (after filament warmup time of 40 seconds). When S701 is in the CW position, contact 11 is grounded through contact 12. When S701 is in the VOICE/FSK position, contact 11 is connected to contact 2 or 3, and the lv dynamotor or low-voltage transistor-type Power supply is energized by closing the microphone switch or key.

#### **7-6. Maintenance of Transmitter Control C-822/GRC-19**

Troubleshooting Transmitter Control C-822/GRC-19 is simplified by the fact that faults

which do not appear at the transmitter for identical functions, but do appear at the remote control unit will isolate the trouble to this unit or to the remote control cable. For example, if the TUNING INDICATOR does not light at the remote control unit but lights at the transmitter, then trouble is in the remote control unit circuit. To replace lamp I701, turn the jewel at the front panel in a counterclockwise direction, remove the jewel, and install a new lamp. If the trouble still remains, check the remote control cable for faulty connections or wiring. If a good spare cable is available, check by substituting it in place of the old one. This approach can be used to check out the proper functioning of the PRESET CHANNELS and SERVICE SELECTOR switches not only at the remote control unit, but for the same switches at the transmitter. The proper functioning of the transmitter and the interconnecting cabling should be established before sending out the remote control unit for repair. There are no special maintenance techniques for the remote control unit other than those outlined wherever applicable in paragraph 2-5 of TM 11-5820-355-10.

#### **7-7. Mounting MT-925/GRC-19**

This mount is used to secure Radio Transmitter T-195/GRC-19 in a vehicle. The eight shock absorbers protect the transmitter from damage as a result of vibration and impact while in transit. The transmitter is locked in position by the three screw-type devices at the front of the mount. The mount is fastened to the vehicle structure by its base plate, using four screws or bolts and nuts.



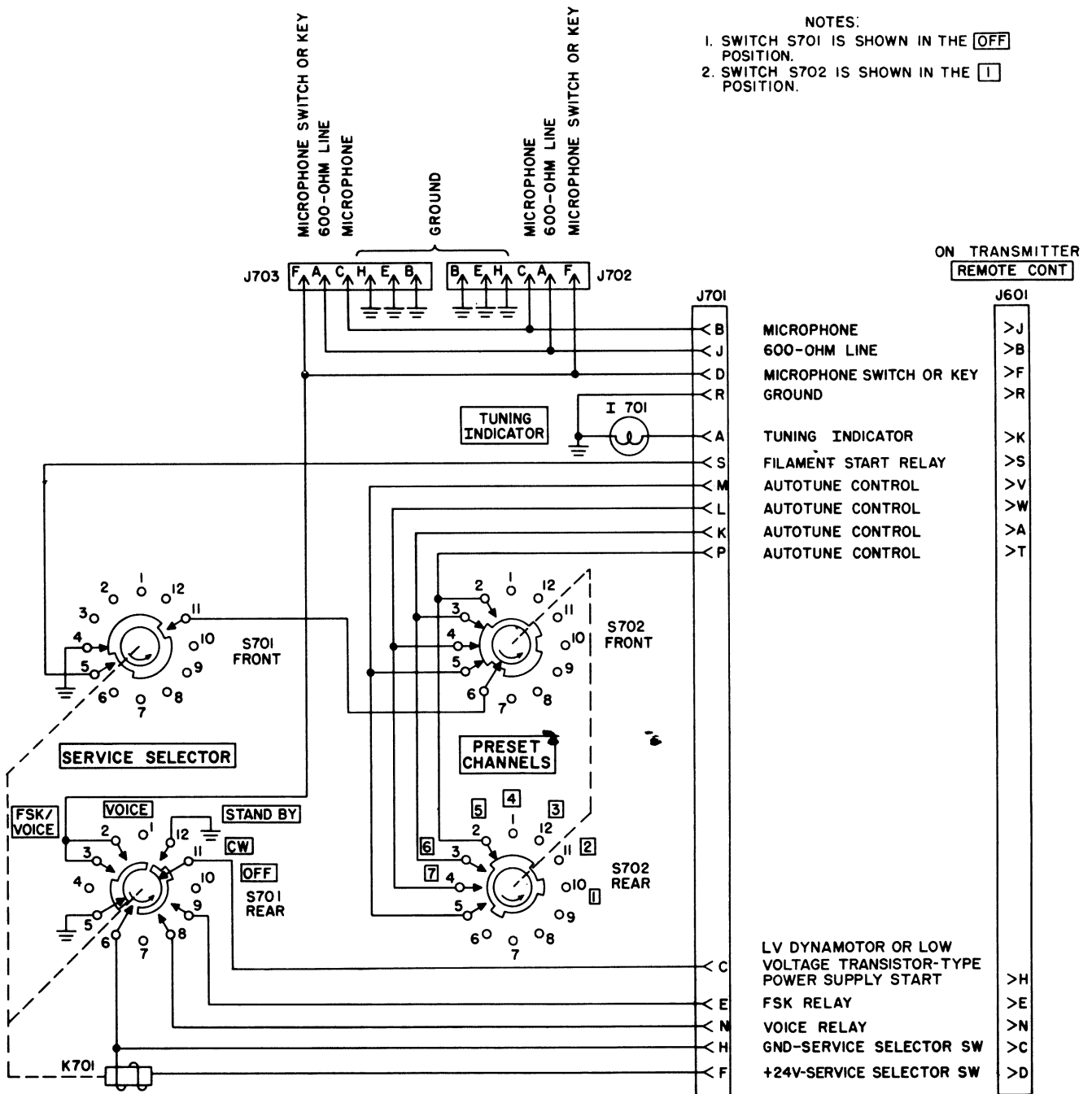

TM5820-335-35-1

Figure 7-5. Transmitter Control C-882/GRC-19, schematic diagram.

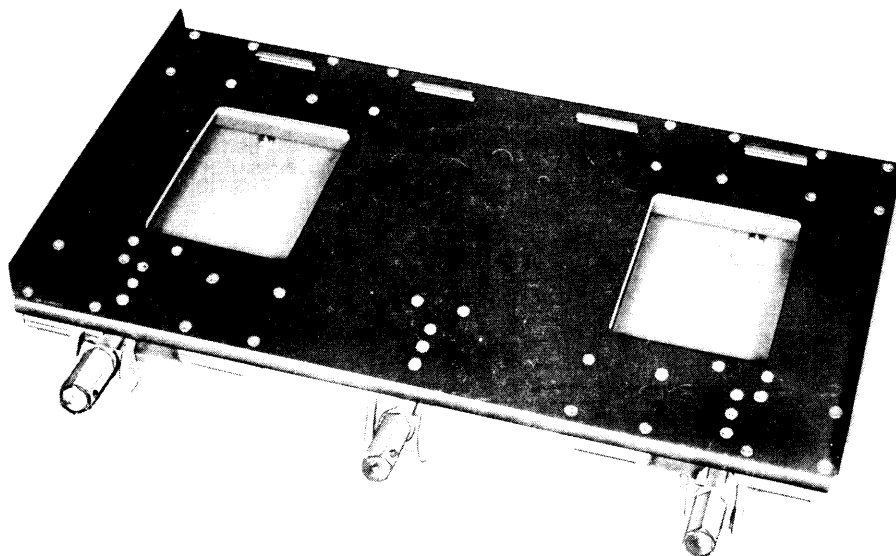

TM 806-7

Figure 7-6. Mounting MT-925/GRC-19.

## Section II. RADIO SET CONTROL GROUP OA-1754/GRC

### 7-8. Purpose and Description of Radio Set Control Group OA-1754/GRC (fig. 7-7)

a. The OA-1754/GRC consists of Switching Unit SA-708/GRC (figs. 7-7 and 7-8) and Relay Unit RE-479/GRC (figs. 7-9). The equipment is used to provide remote control (up to one mile) of a T-195/GRC-19 for fsk or cw operation.

b. The RE-479/GRC is installed on the T-195/GRC; the CA-708/GRC is installed at the remote site. The two units are interconnected by a suitable two-conductor line. The desired type of operation is obtained by operation of the FSK ON switch and Telegraph Key KY-116/U as required (para 7-10).

### 7-9. Installation (fig. 7-7 and 7-10)

#### a. RE-479/GRC.

(1) Plug the RE-479/GRC (receptacle J101) into the T-195/GRC AUDIO receptacle (J603).

(2) Remove fuse cap FUSE 15 AMP 24 VOLT from the T-195/GRC. Substitute the modified fuse cap (fig. 7-7) supplied as part of the RE-479/GRC.

(3) Insert connector P101 of WS-16/U into the jack of the modified fuse cap.

#### b. SA-708/GRC.

(1) Mount the SA-708/GRC as convenient.

Use the angle bracket to secure the unit as practical.

(2) For cw operation, connect Telegraph Key KY-116/U to receptacle J1 on the SA-708/GRC through a cable assembly such as CX-1852/U (fig. 7-10).

c. *Line.* Connect an appropriate two-conductor line, not exceeding one mile in length, between the LINE binding posts of the RE-479/GRC and the LINE binding posts of the SA-708/GRC.

### 7-10. Operation

Be sure that the SERVICE SELECTOR switch of the T-195/GRC is in the VOICE/FSK position. For fsk operation, operate the FSK ON switch (fig. 7-7) to the up (on) position; for cw operation, operate the FSK ON switch to the down (off) position and use the KY-116/U as required.

### 7-11. Functioning

A simplified schematic diagram of a system using components of the OA-1754/GRC is shown in figure 7-10. If the FSK ON switch (or the KY-116/U) is operated to close the circuit, relay K101 operates and contacts 1-2 make. This causes the T-195/GRC to function in the same manner as when the KY-116/U is connected directly to the AUDIO receptacle J603.

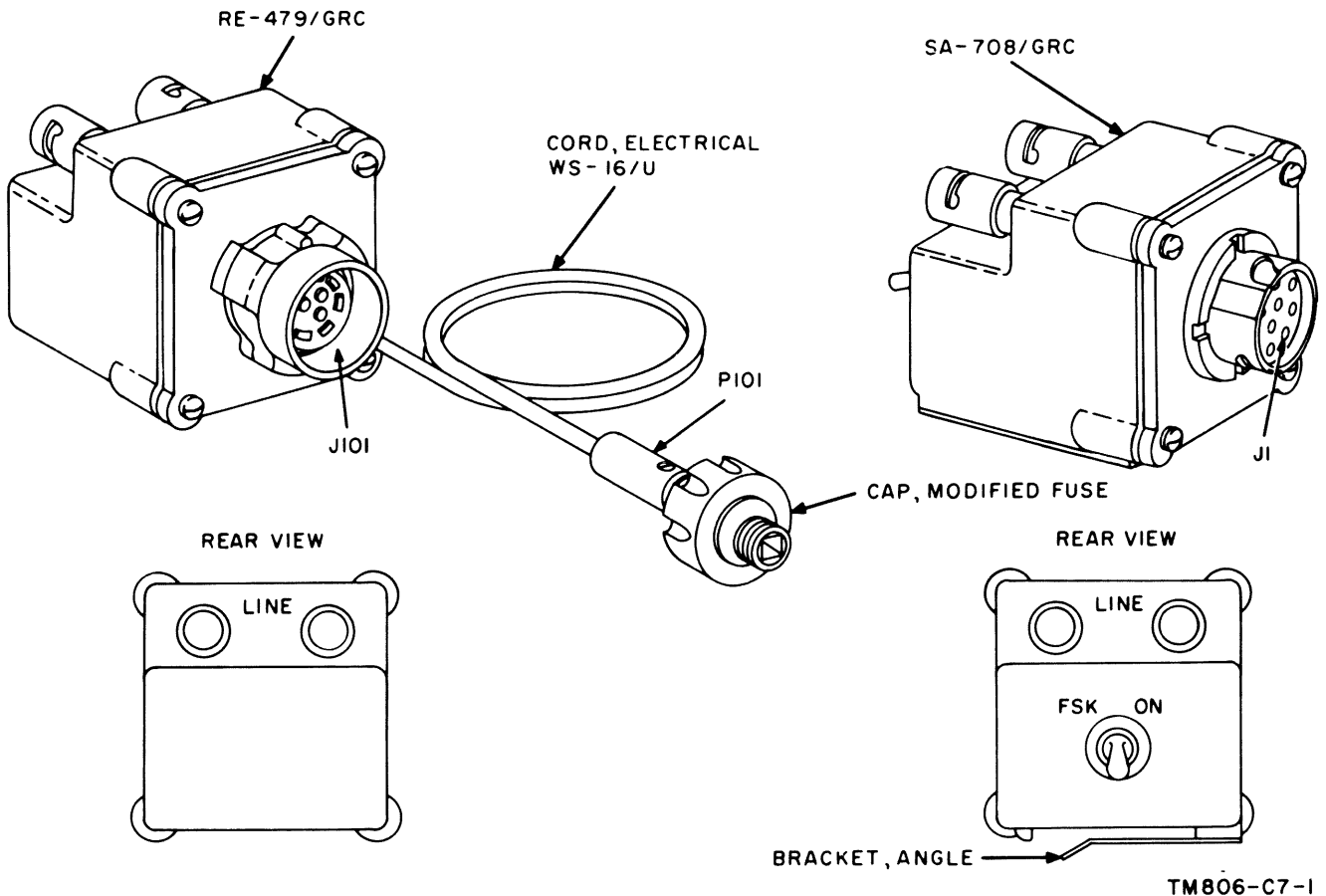

Figure 7-7. Radio Set Control Group OA-1754/GRC.

### 7-12. Troubleshooting

If the system fails to function properly, notify the organizational maintenance personnel to make the following checks as required.

a. Check to see that 24 volts dc is present between the jack on the modified fuse cap (installed on the T-195/GRC) and ground.

b. If 24 volts dc is present, sectionalize the trouble as follows:

(1) Place a short across the LINE binding posts of the RE-479/GRC. The transmitter should operate. If it does not, replace the RE-479/GRC and forward the defective unit for higher echelon maintenance.

(2) Place a short across the LINE binding posts of the SA-708/GRC. The transmitter should operate. If it does not, check the line connections at the RE-479/GRC and the SA-708/GRC. Replace the line between the units as required.

(3) Operate the FSK ON switch of the SA-708/GRC to the up (on) position. The transmitter should operate. If it does not, replace the SA-708/GRC and forward the defective unit for higher echelon maintenance.

(4) If the system is connected with a KY-116/U as shown in figure 7-10 and the above checks ((1) through (3)) fail to disclose the fault, check continuity between the SA-708/GRC and the KY-116/U. Replace the defective equipment as required.

### 7-13. Repair (Direct Support Maintenance) (fig. 7-8 and 7-9)

To repair a defective unit, disassemble as required. Use figures 7-8 and 7-9 as a guide. Repair defective wiring or replace a defective part as required. Reassemble the unit.

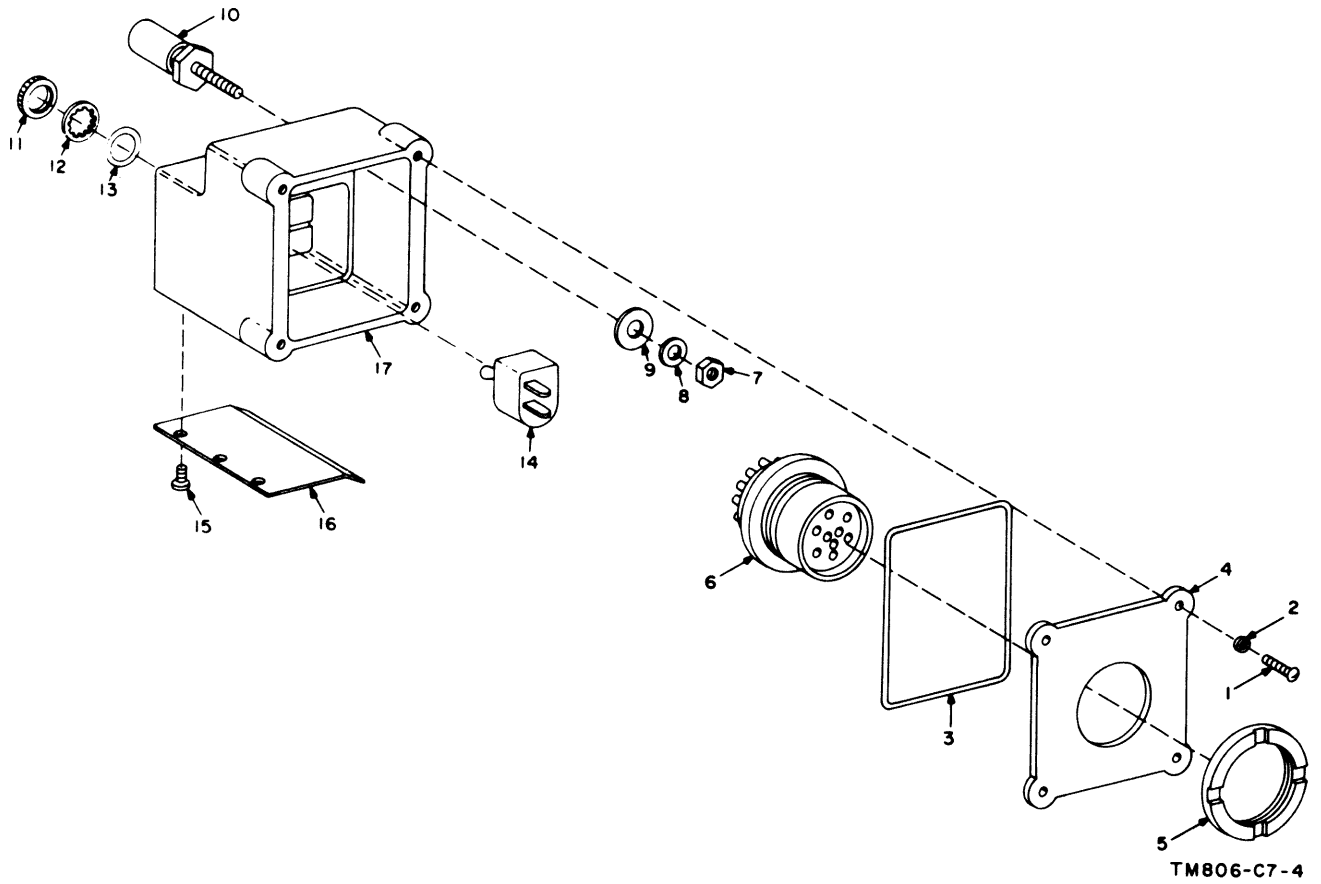

Figure 7-8. Switching Unit SA-708/GRC, exploded view.

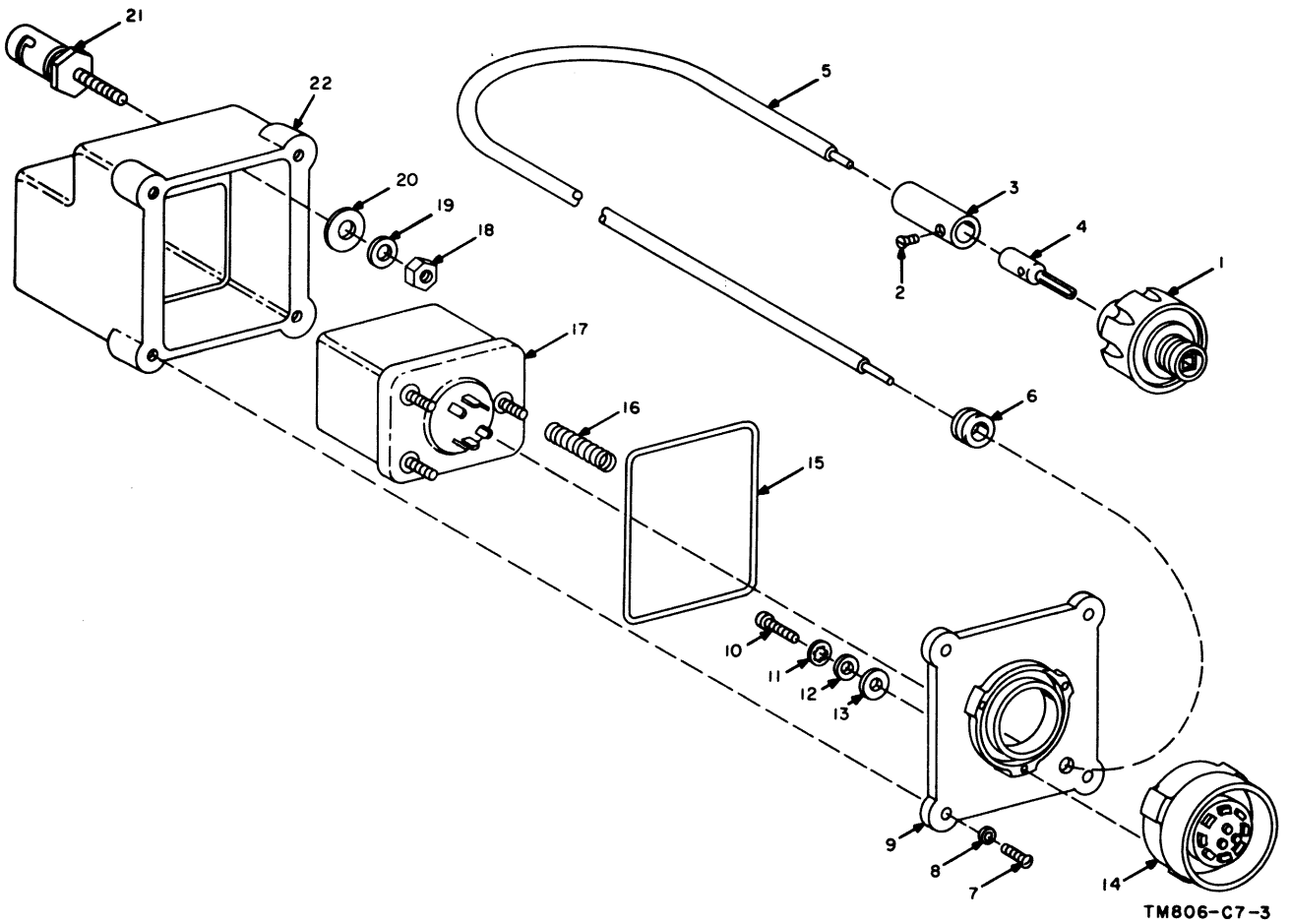
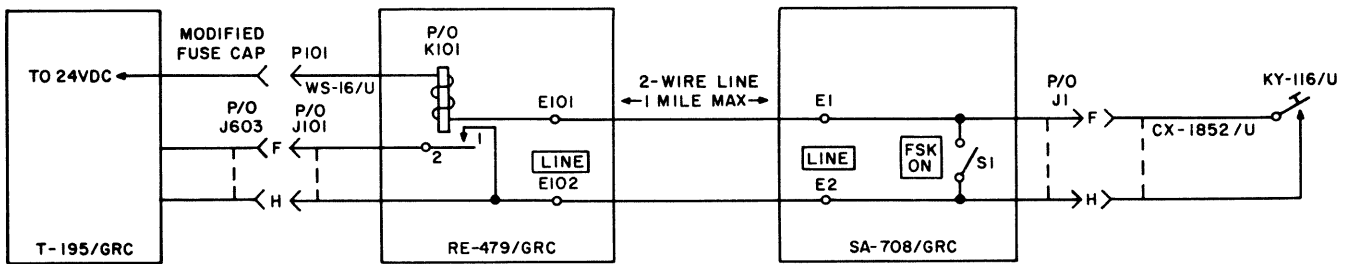

Figure 7-9. Relay Unit RE-479/GRC, exploded view.



NOTE:  
RECEPTACLE AND CONNECTOR PINS, SWITCH CONTACTS,  
AND RELAY CONTACTS NOT USED ARE NOT SHOWN.

TM806-C7-5

Figure 7-10. System simplified schematic diagram using OA-1754/GRC.



## APPENDIX A

### REFERENCES

Following is a list of applicable manuals that are available to personnel concerned with Transmitters, Radio T-195/GRC-19, T-195A/GRC-19 and T-195B/GRC-19.

DA Pam 310-4	Index of Technical Manuals, Technical Bulletins, Supply Manuals (types 7, 8, and 9) Supply Bulletins, and Lubrication Orders.
DA Pam 310-7	U. S. Army Equipment Index of Modification Work Orders.
SB 38-100	Preservation, Packaging and Packing Materials, Supplies, and Equipment Used by the Army.
TB 746-10	Field Instructions for Painting and Preserving Electronics Command Equipment.
TB SIG 291	Safety Measures to be Observed When Installing and Using Whip Antennas, Field Type Masts, Towers, Antennas, and Metal Poles That Are Used with Communication, Radar and Direction Finder Equipment.
TM 11-5820-295-10	Operator's Manual Radio Set AN/GRC-19.
TM 11-5820-295-20	Organizational Maintenance: Radio Set AN/GRC-19.
TM 11-5820-295-20P	Organizational Maintenance Repair Parts and Special Tool Lists: Radio Set AN/GRC-19.
TM 11-5820-295-35	Field and Depot Maintenance Manual: Radio Set, AN/GRC-19 (TO 31R2-2GRC19-42).
TM 11-5820-295-35P	Field and Depot Maintenance Repair Parts and Special Tool Lists: Radio Set AN/GRC-19 (TO 31R2-2GRC-304).
TM 11-5820-335-10	Operator's Manual Transmitters, Radio T-195/GRC-19, T-195A/GRC-19, and T-195B/GRC-19.
TM 11-5820-335-20	Organizational Maintenance Manual, Transmitters, Radio T-195/GRC-19, T-195A/GRC-19 and T-195B/GRC-19.
TM 11-5820-335-20P	Organizational Maintenance Repair Parts and Special Tools List: Transmitter, Radio T-195/GRC-19, T-195A/GRC-19 and T-195B/GRC-19.
TM 11-5820-335-35P	DS, GS, and Depot Maintenance Repair Parts and Special Tool Lists: Transmitter, Radio T-195/GRC-19, T-195A/GRC-19 and T-195B/GRC-19.





## APPENDIX B

### GLOSSARY OF TERMS

---

- Autotune*—The name applied to an electromechanical system which automatically positions a shaft to a predetermined setting.
- Control head*—The electrical part of an Autotune system which controls the positioning heads.
- Frequency-shift keying*—Method of keying a receiving teletypewriter by shifting the transmitted carrier frequency to a slightly different value.
- Home position*—That position to which a variable circuit component always is returned, before adjustment to a new position.
- Homing*—Positioning of circuit parts before final adjustment.
- Multiturn positioning head*—A mechanical part of an Autotune system which will rotate a shaft several times, if necessary, to a predetermined position.
- Servo*—The name applied to a power-amplifying system which will position a shaft according to the polarity and amplitude of a correction voltage.
- Sidetone*—Audio signal used for monitoring transmissions.
- Singleturn positioning head*—A mechanical part of an Autotune system which will rotate a shaft one complete revolution, if necessary, to a predetermined position.
- Subchassis*—The name applied to a removable assembly which performs a major function in the transmitter.



# INDEX

	Paragraph	Page
Adjustment of antenna-tuning capacitor -----	3-15	3-34
Antenna tuning capacitor synchronization, fig. 3-14 -----		3-35
Adjustment of frequency-indicator assembly -----	3-14	3-34
Adjustment of modulator subchassis -----	3-7	3-29
Adjustment of speed regulator -----	3-13	3-33
Adjustment and testing of discriminator subchassis -----	3-11	3-31
Alinement and calibration of master-oscillator subchassis -----	3-12	3-33
Alinement of exciter subchassis -----	3-10	3-31
Antenna network servo amplifier -----	1-31	1-46
Antenna network servo amplifier, amplifying circuits, functional diagram, fig. 1-37 -----		1-52
Antenna network servo amplifier, input circuits, functional diagram, fig. 1-35 -----		1-50
Antenna network servo amplifier, output circuits, functional diagram, fig. 1-38 -----		1-53
Antenna network servo amplifier, transistorized chopper, schematic diagram, fig. 1-36 -----		1-51
Antenna switching and keying circuits -----	1-33	1-48
Antenna tuning system -----	1-27	1-35
Antenna tuning system, simplified, fig. 1-28 -----		1-37
Autotune control circuit -----	1-37	1-62
Autotune control circuits, functional diagram, fig. 1-44 -----		1-65
Hermetically sealed autotune relay K601, schematic diagram, fig. 1-45 -----		1-68
Hermetically sealed autotune relay K610 (used in T-195B/GRC-19 on Order No. 4096-PP-60), schematic diagram, fig. 1-46 -----		1-68
Hermetically sealed receiver antenna-relay K615 (used in T-195B/GRC-19 on Order No. 4096-PP-60), schematic diagram, fig. 1-42 -----		1-61
Autotune system -----	1-36	1-62
Autotune circuits, flow chart, fig. 1-43 -----		1-63
Auxiliary equipment:		
Circuit description -----	7-5	7-3
Transmitter Control C-822/GRC-19, schematic diagram, fig. 7-6 -----		7-6
Connections -----	7-3	7-1
Transmitter Control C-822/GRC-19, cording diagram, fig. 7-4 -----		7-3
Description of Electrical Special Purpose Cable Assembly CX-2585/U -----	7-2	7-1
Description of Transmitter Control C-822/GRC-19 -----	7-1	7-1
Electrical Special Purpose Cable Assembly CX-2585/U, fig. 7-2 -----		7-1
Transmitter Control C-822/GRC-19, with backplate removed, fig. 7-3 -----		7-2
Transmitter Control C-822/GRC-19, front oblique view, fig. 7-1 -----		7-1
Installation -----	7-9	7-6
System simplified schematic diagram using OA-1754/GRC, fig. 7-11 -----		7-11
Maintenance of Transmitter Control C-822/GRC-19 -----	7-6	7-4
Mounting MT-925/GRC-19 -----	7-7	7-4
Mounting MT-925/GRC-19, fig. 7-7 -----		7-7
Operation -----	7-10	7-6
Operation from Transmitter Control C-822/GRC-19 -----	7-4	7-2
Transmitter Control C-822/GRC-19 front panel, fig. 7-5 -----		7-5
Purpose and description of Radio Set Control Group OA-754/GRC		
Radio Set Control Group OA-1754/GRC, fig. 7-8 -----		7-8
Relay Unit RE-479/GRC, exploded view, fig. 7-10 -----		7-9
Switching Unit SA-708/GRC, exploded view, fig. 7-9 -----		7-9
Repair (direct support) -----	7-13	7-7
Theory -----	7-11	7-7
Troubleshooting -----	7-12	7-7
Block diagrams:		
Antenna tuning system, block diagram, fig. 1-29 -----	1-28	1-36
Exciter, block diagram, fig. 1-9 -----	1-9	1-9

	Paragraph	Page
Master oscillator, block diagram, fig. 1-6 .....	1-5	1-7
Modulator, block diagram, fig. 1-21 .....	1-19	1-28
Power amplifier, block diagram, fig. 1-15 .....	1-15	1-16
Radio Transmitter T-195/GRC-19, composite block diagram, fig. 1-5 .....	1-4	1-4
Buffer amplifier V802 .....	1-7	1-8
Checking filament and B+ circuits for shorts .....	2-6	2-8
Circuit analysis .....	1-35	1-57
Antenna switch and keying circuits, functional diagram, fig. 1-41 .....		1-59
Clamper V202 .....	1-17	1-18
Condition of test .....	6-4	6-1
Dc resistance of transformers, coils and motors .....	2-11	2-94
Disassembly and reassembly of autotune mechanism .....	3-2	3-8
Disassembly of autotune motor, fig. 3-5 .....		3-21
Disassembly of autotune control head, fig. 3-4 .....		3-15
Disassembly of autotune multiturn head, fig. 3-3 .....		3-13
Disassembly of autotune single turn head, fig. 3-2 .....		3-11
Lubrication of autotune single turn head, fig. 3-6 .....		3-22
Distribution, 24-volt .....	1-42	1-75
24-volt distribution, functional diagram, fig. 1-51 .....		1-77
Hermetically sealed autotune relay K608 (used in T-195B/GRC-19 on Order No. 4096-PP-60), schematic diagram, fig. 1-52 .....		1-81
Hermetically sealed L V relay K602 (used in T-195B/GRC-19 on Order No. 4096-PP-60), schematic diagram, fig. 1-53 .....		1-82
Distribution, -45-volt .....	1-45	1-82
Distribution, 115-volt, 400-cps .....	1-43	1-81
Distribution, functional diagram, fig. 1-54 .....		1-83
Distribution, +250-volt .....	1-44	1-82
Distribution, functional diagram, fig. 1-55 .....		1-85
Distribution, +1,000-volt .....	1-46	1-82
Driver V104 .....	1-13	1-11
Driver stage, functional diagram, fig. 1-13 .....		1-15
Exciter neutralization .....	1-14	1-13
Neutralization circuit, functional diagram, fig. 1-14 .....		1-16
Fabrication procedures .....	2-5	2-4
Dummy antenna, fig. 2-2 .....		2-7
Fabrication of test cables, fig. 2-1 .....		2-6
Final testing .....	2-9	2-18
First audio amplifier V401B .....	1-22	1-31
First audio amplifier, functional diagram, fig. 1-24 .....		1-32
First multiplier V101 .....	1-10	1-9
First multiplier stage, functional diagram, fig. 1-10 .....		1-12
Flow chart .....	1-34	1-57
Antenna switching and keying, flow chart, fig. 1-40 .....		1-58
Frequency comparison and operation tests .....	5-8	5-12
Frequency comparison and operation tests, fig. 5-5 .....		5-10
General instructions .....	2-1	2-1
High-voltage transistor-type power supply .....	1-52	1-93
Transistor-type, high-voltage power supply, complete schematic diagram, fig. 1-63 .....		1-96
High-voltage transistor-type power supply PS602 operation .....	1-53	1-95
High-voltage power supply PS602 schematic diagram, fig. 1-64 .....		1-98
Homing circuits .....	1-29	1-37
Homing circuits, functional diagram, fig. 1-31 .....		1-41
Homing cycle flow chart, fig. 1-30 .....		1-39
Internal differences in models .....	1-2	1-1
Auxiliary dust filter assembly with filter removed, fig. 1-1 .....		1-2
Auxiliary dust filter assembly installed, fig. 1-2 .....		1-3
Limiter V402 .....	1-21	1-29
Limiter stage, function diagram, fig. 1-23 .....		1-32
Localizing and isolating troubles .....	2-8	2-12
Antenna network servo amplifier, bottom view, fig. 2-28 .....		2-37
Antenna network servo amplifier, cover removed, top view, fig. 2-26 .....		2-36

	Paragraph	Page
Antenna network servo amplifier, oblique side view, fig. 2-27	-----	2-37
Antenna network servo amplifier, schematic diagram, fig. 2-77	-----	2-82
Antenna network servo amplifier subchassis, terminal board measurements, fig. 2-63	-----	2-65
Antenna network servo amplifier terminal board removed, fig. 1-29	-----	1-38
Antenna tuning capacitor subchassis, left view, fig. 2-31	-----	2-39
Antenna tuning capacitor subchassis, right view, fig. 2-30	-----	2-38
Antenna tuning capacitor subchassis, schematic diagram, fig. 2-78	-----	2-83
Discriminator subchassis, bottom view, fig. 2-20	-----	2-30
Discriminaor subchassis, left view, fig. 2-19	-----	2-30
Discriminator subchassis, right view, fig. 2-18	-----	2-29
Discriminator subchassis schematic dagram, fig. 2-26	-----	2-36
Discriminator subchassis, terminal board measurements, fig. 2-62	-----	2-64
Exciter subchassis, bottom view, fig. 2-8	-----	2-22
Exciter subchassis, front view, fig. 2-10	-----	2-24
Exciter subchassis, schematic diagram, fig. 2-73	-----	2-75
Exciter subchassis, side view, fig. 2-9	-----	2-23
Exciter subchassis, terminal board measurements, fig. 2-59	-----	2-61
Exciter subchassis, top view, fig. 2-7	-----	2-21
Exhaust blower, terminal board measurements, fig. 2-67	-----	2-69
High-voltage power supply A1200, bottom view, fig. 2-35	-----	2-41
High-voltage power supply A1200, (MOD 1), bottom view, fig. 2-37	-----	2-42
High-voltage power supply A1200, side view, fig. 2-34	-----	2-40
High-voltage power supply A1200, voltage and resistance diagram, fig. 2-64	-----	2-66
High-voltage power supply A1200, (MOD 1), side view, fig. 2-36	-----	2-41
High-voltage power supply A1200, (MOD 1) voltage and resistance diagram, fig. 2-83	-----	2-93
High-voltage power supply PS602, bottom view, cover removed, fig. 2-46	-----	2-49
High-voltage power supply PS602, terminal board measurements, fig. 2-70	-----	2-72
High-voltage power supply PS602 top view, cover removed, fig. 2-45	-----	2-48
High-voltage power supply, terminal board measurements, fig. 2-69	-----	2-71
High-voltage power supply A1200, top view, fig. 2-33	-----	2-40
Low-voltage power supply PS601, bottom view, cover removed, fig. 2-48	-----	2-50
Low-voltage power supply PS601, terminal board measurements, fig. 2-71	-----	2-73
Low-voltage power supply, terminal board measurements, fig. 2-68	-----	2-70
Low-voltage power supply PS601 top view, cover removed, fig. 2-47	-----	2-50
Main frame, bottom oblique view, fig. 2-54	-----	2-54
Main frame, bottom view, fig. 2-53	-----	2-53
Main frame, front panel and frequency indicator removed, fig. 2-56	-----	2-56
Main frame, front panel removed, fig. 2-55	-----	2-55
Main frame MOD 5A and higher, bottom view of regulator assembly, fig. 2-52	-----	2-53
Main frame, rear right view, fig. 2-50	-----	2-51
Main frame, regulator subassembly removed, fig. 2-51	-----	2-52
Main frame, schematic diagram, fig. 2-80	-----	2-85
Main frame, terminal board measurements, fig. 2-65	-----	2-67
Main frame, top view, fig. 2-49	-----	2-51
Master-oscillator subchassis bottom view, fig. 2-4	-----	2-20
Master-oscillator subchassis, bottom view, sealed circuit, cover removed, fig. 2-5	-----	2-20
Master-oscillator subchassis, schematic diagram, fig. 2-72	-----	2-74
Master-oscillator subchassis, top view, fig. 2-3	-----	2-19
Master-oscillator subchassis, top view, sealed circuit cover removed, fig. 2-6	-----	2-20
Modulator subchassis, bottom view, fig. 2-23	-----	2-33
Modulator subchassis, rear view, fig. 2-25	-----	2-35
Modulator subchassis, schematic diagram, fig. 2-75	-----	2-79
Modulator subchassis, terminal board measurements, fig. 2-60	-----	2-62
Modulator subchassis, terminal board removed, fig. 2-24	-----	2-66
Modulator subchassis, top view, fig. 2-21	-----	2-31
Modulator subchassis with modulator tube subassembly removed, fig. 2-22	-----	2-32
Power-amplifier discriminator, terminal board, fig. 2-17	-----	2-29
Power-amplifier discriminator, bottom view, fig. 2-16	-----	2-28
Power-amplifier subchassis, bottom view, fig. 2-12	-----	2-26
Power-amplifier subchassis, front view, fig. 2-14	-----	2-27
Power-amplifier subchassis, pa blower terminal board measurements, fig. 2-66	-----	2-68
Power-amplifier subchassis, rear view, fig. 2-15	-----	2-28
Power-amplifier subchassis, schematic diagram, fig. 2-74	-----	2-77

	Paragraph	Page
Power-amplifier subchassis, side view, fig. 2-13	-----	2-27
Power-amplifier subchassis terminal board measurements, fig. 2-61	-----	2-63
Power-amplifier subchassis, top-view, fig. 2-11	-----	2-25
Radio Transmitter T-195/GRC-19, bottom deck, tube voltage resistance diagram, fig. 2-58	-----	2-59
Radio Transmitter T-195/GRC-19, schematic diagram, fig. 2-82.	-----	2-89
Radio Transmitter T-195/GRC-19, top deck, tube and resistance diagram, fig. 2-57	-----	2-57
Subchassis interconnection, cabling diagram, fig. 2-81	-----	2-87
Transistor-type exhaust blower PS602, side view, fig. 2-43	-----	2-47
Transistor-type high-voltage power supply, side view, interior, fig. 2-42	-----	2-46
Transistor-type high-voltage power supply, top view, interior, fig. 2-41	-----	2-45
Transistor-type low-voltage power supply, bottom view, fig. 2-39	-----	2-43
Transistor-type low-voltage power supply, interior view, fig. 2-40	-----	2-44
Transistor-type low-voltage power supply, location of frequency adjustment control, fig. 2-38	-----	2-42
Transistor-type pa blower B202, transistor power supply removed, fig. 2-44	-----	2-47
Variable inductor subchassis, schematic diagram, fig. 2-79	-----	2-84
Low-voltage transistor-type power supply	1-51	1-90
Transistor-type low-voltage power supply, complete schematic diagram, fig. 1-62.	-----	1-94
Low-voltage transistor-type power supply PS601 operation	1-54	1-83
Low-voltage power supply PS601, schematic diagram, fig. 1-65	-----	1-101
Lubrication	3-3	3-13
Lubrication of autotune multiturn head, front and top views, fig. 3-7	-----	3-24
Lubrication of autotune multiturn head, left and right views, fig. 3-8	-----	3-25
Lubrication of autotune control head, fig. 3-9	-----	3-26
Lubrication of autotune line shaft, fig. 3-10	-----	3-27
Lubrication of frequency indicator, fig. 3-11	-----	3-27
Radio Transmitter T-195/GRC-19, modulator adjustments, fig. 3-12	-----	3-28
Maintenance instructions	4-1	4-1
Modification work orders	5-4	5-2
Modulation test	5-7	5-11
Modulation test, fig. 5-4	-----	5-8
Modulator tubes V406 and V407	1-25	1-31
Modulator stage, functional diagram, fig. 1-26	-----	1-33
Multiturn positioning head	1-39	1-69
Multiturn positioning head, representative drawing, fig. 1-48	-----	1-71
Operational test	2-7	2-21
Organization of troubleshooting procedures	2-2	2-7
Oscillator frequency stabilization	1-8	1-8
Thermostat S801, simplified schematic, fig. 1-8	-----	1-9
Oscillator V801	1-6	1-7
Master-oscillator stages, functional diagram, fig. 1-7	-----	1-8
Output capacitor	1-32	1-50
Output capacitor, functional diagram, fig. 1-39	-----	1-55
Parts lubricated by manufacturers	3-4	3-23
Phase inverter V404B	1-24	1-31
Phasing and loading discriminator	1-30	1-44
Loading discriminator, functional diagram, fig. 1-34	-----	1-49
Phasing discriminator, functional diagram, fig. 1-32	-----	1-47
Phasing discriminator, voltage relationships, fig. 1-33	-----	1-48
Physical tests and inspection	5-5	5-10
Physical tests and inspection, fig. 5-2	-----	5-4
Power-amplifier tuning	1-18	1-21
Power-amplifier chopper and servo amplifier stages, functional diagram, fig. 1-20	-----	1-28
Power-amplifier discriminator, fig. 1-19	-----	1-27
Power-amplifier discriminator circuits, fig. 1-18	-----	1-26
Power-amplifier plate circuit, functional diagram, fig. 1-17	-----	1-23
Power amplifier V201	1-16	1-16
Power-amplifier and clamper stages, functional diagram, fig. 1-16	-----	1-19

	Paragraph	Page
Power circuits and servo motors -----	1-41	1-59
Power circuits, flow chart, fig. 1-50 -----		1-76
Preamplifier V401A -----	1-20	1-28
Preamplifier stage, functional diagram, fig. 1-22 -----		1-30
Preliminary procedures -----	6-5	6-9
Purpose of final testing -----	6-2	6-1
Removals and replacements -----	3-1	3-1
Variable inductor ribbon replacement, fig. 3-1 -----		3-9
Resistance measurements of receptacles and connectors -----	2-11	2-94
Scope -----	1-1	1-1
Scope of maintenance -----	6-1	6-1
Second audio amplifier V404A -----	1-23	1-31
Second audio amplifier and phase inverter, functional diagram, fig. 1-25 -----		1-33
Second multiplier V102 -----	1-11	1-11
Second multiplier stage, functional diagram, fig. 1-11 -----		1-13
Servo motor operation -----	1-48	1-87
Servo mechanism operation, fig. 1-59 -----		1-91
Sidetone amplifier V402A -----	1-26	1-33
Sidetone amplifier stage, functional diagram, fig. 1-27 -----		1-35
Single turn positioning head -----	1-38	1-68
Single turn positioning head, simplified drawing, fig. 1-47 -----		1-82
Special requirements -----	5-3	5-1
Special test cable construction details, fig. 5-1 -----		5-2
Summary of performance standards -----	5-8	5-12
Summary of transmitter tuning -----	1-40	1-73
Complete tuning cycle, flow chart, fig. 1-49 -----		1-74
Synchronization of autotune mechanism -----	3-6	3-29
Synchronization of band switch in exciter subchassis -----	3-8	3-30
Extra bandswitching synchronizing, fig. 3-13 -----		3-30
Synchronization of bank switch in power amplifier subchassis -----	3-9	3-30
Synchronization of output capacitor -----	3-16	3-35
Output capacitor synchronization, fig. 3-15 -----		3-36
System applications -----	1-3	1-2
Frequency-shift, single-channel, radio teletype system, simplified block diagram, fig. 1-4 -----		1-4
Radio Set AN/GRC-19, simplified block diagram, fig. 1-3 -----		1-4
Test equipment required -----	6-3	6-1
(Depot maintenance)		
Test equipment required -----	2-4	2-3
(Direct support)		
Test equipment and special tools required -----	3-5	3-28
Test equipment, tools, materials, and other equipment required -----	5-2	5-1
Test procedures -----	6-6	6-2
Third multiplier V103 -----	1-12	1-11
Third multiplier stage, functional diagram, fig. 1-12 -----		1-14
Transistor-type exhaust blower B602 -----	1-49	1-90
Exhaust blower B602, transistor-type, schematic diagram, fig. 1-60 -----		1-92
Transistor-type pa blower B202 -----	1-50	1-90
Pa blower B202 transistor-type, schematic diagram, fig. 1-61 -----		1-92
Transistorized high-voltage power supply operation -----	1-47	1-82
High-voltage power supply A1200, schematic diagram, fig. 1-57 -----		1-88
High-voltage power supply A1200, (MOD 1) schematic diagram, fig. 1-58 -----		1-89
Transistorized power supply, schematic diagram, fig. 1-56 -----		1-87
Troubleshooting data -----	2-3	2-2
Tuning capabilities and power output tests -----	5-6	5-9
Tuning capabilities and power output tests, fig. 6-3 -----		5-6
Voltage and resistance checks -----	2-10	2-93





By Order of the Secretary of the Army:

Official:

KENNETH G. WICKHAM,  
*Major General, United States Army,  
The Adjutant General.*

W. C. WESTMORELAND,  
*General, United States Army,  
Chief of Staff.*

Distribution:

To be distributed in accordance with DA Form 12-51 (qty rqr block #91) direct and general support maintenance requirements for the AN/GRC-19 radio set.











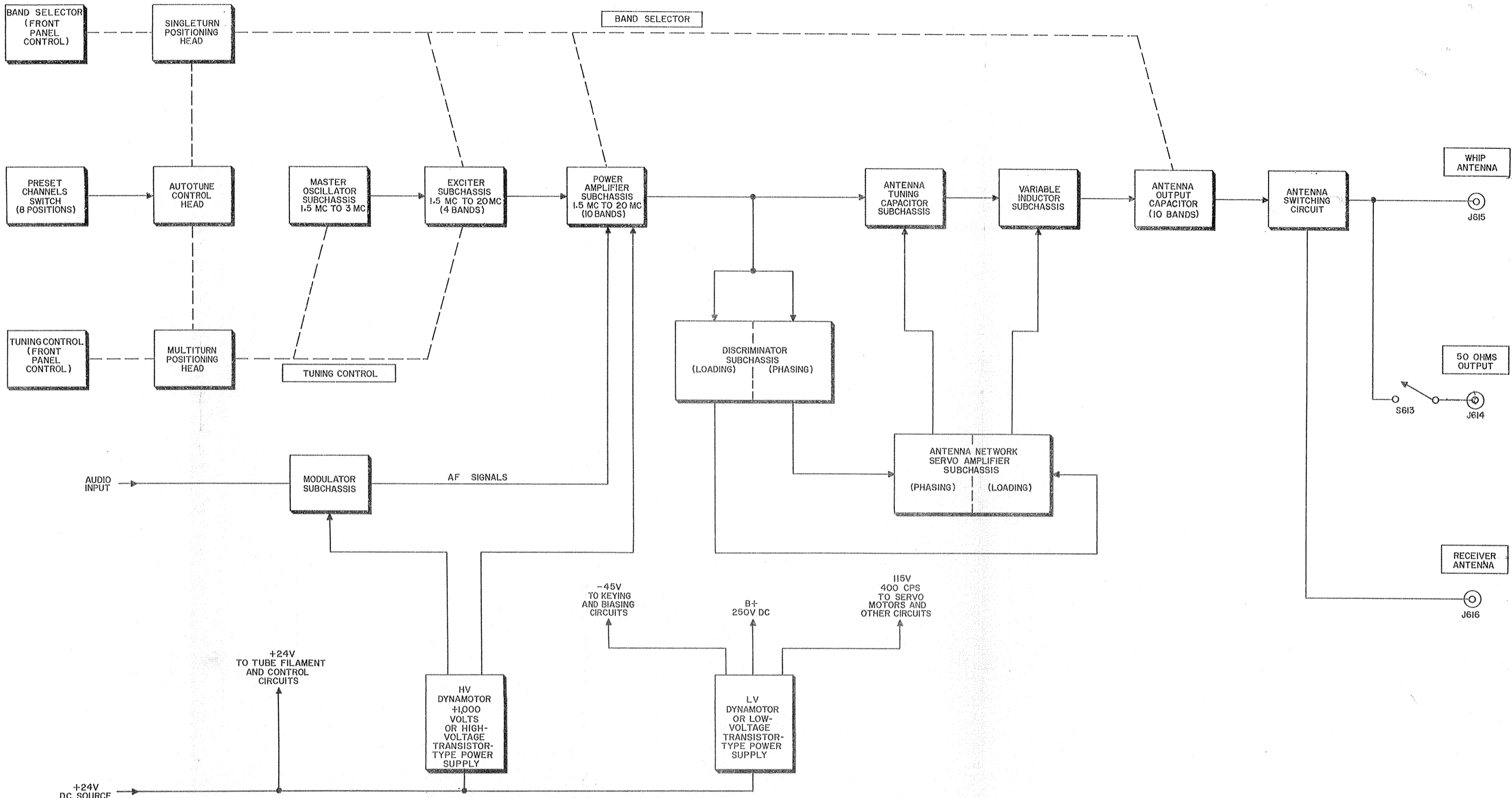

Figure 1-5. Radio Transmitter T-195/GRC-19, composite block diagram.

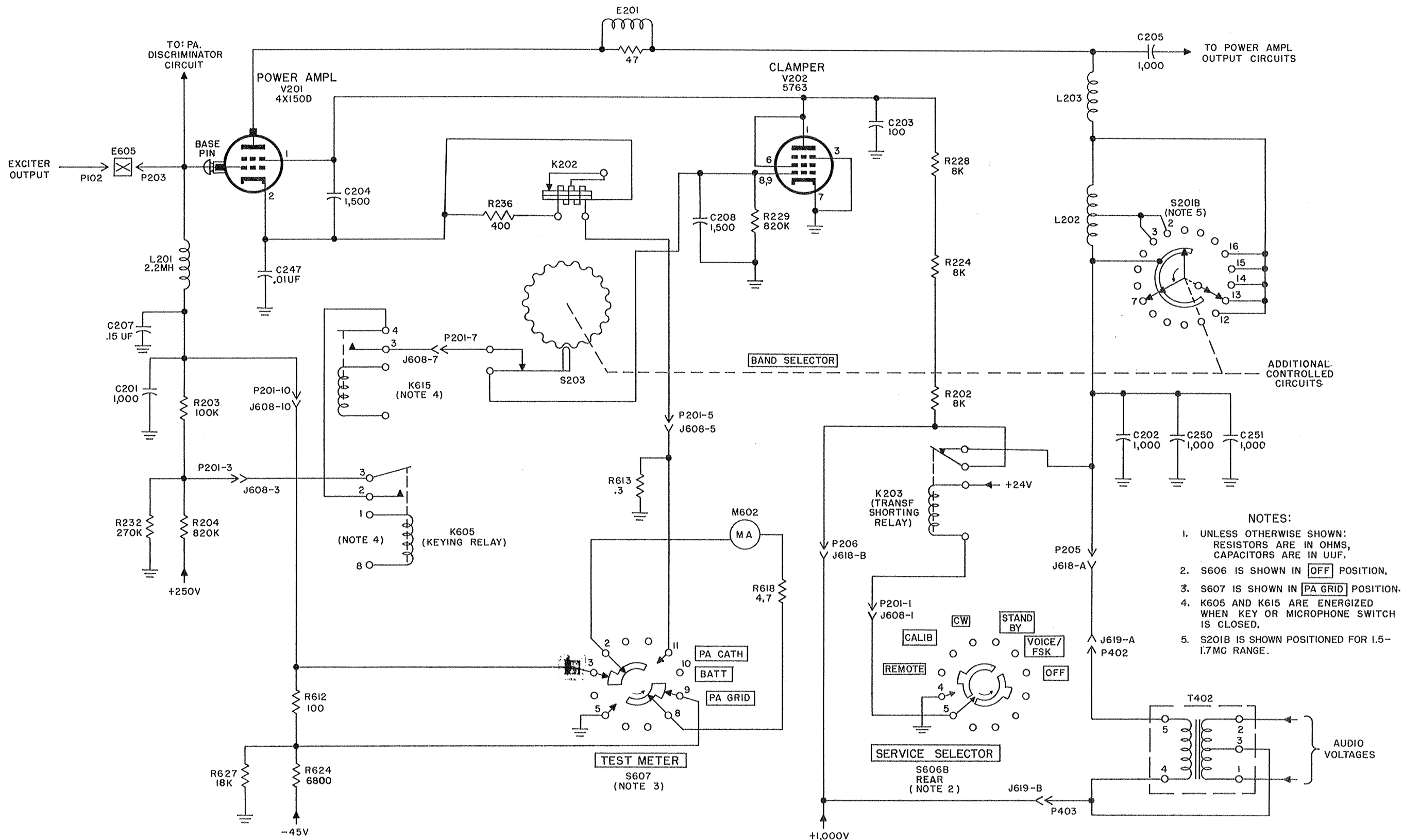

Figure 1-16. Power-amplifier and clamper stages functional diagram.



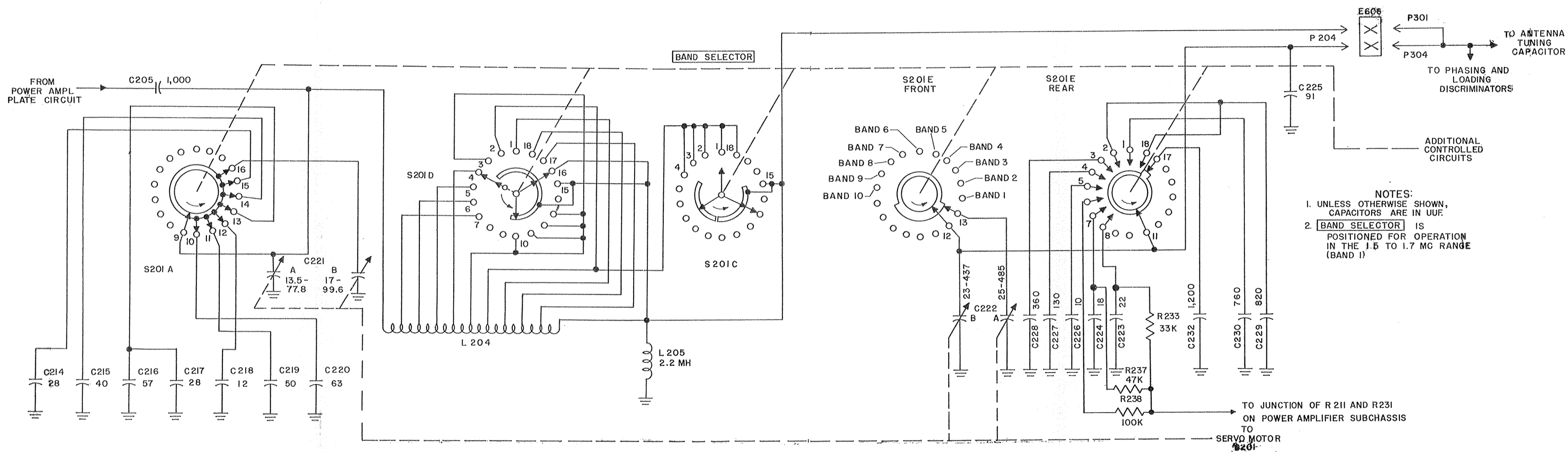
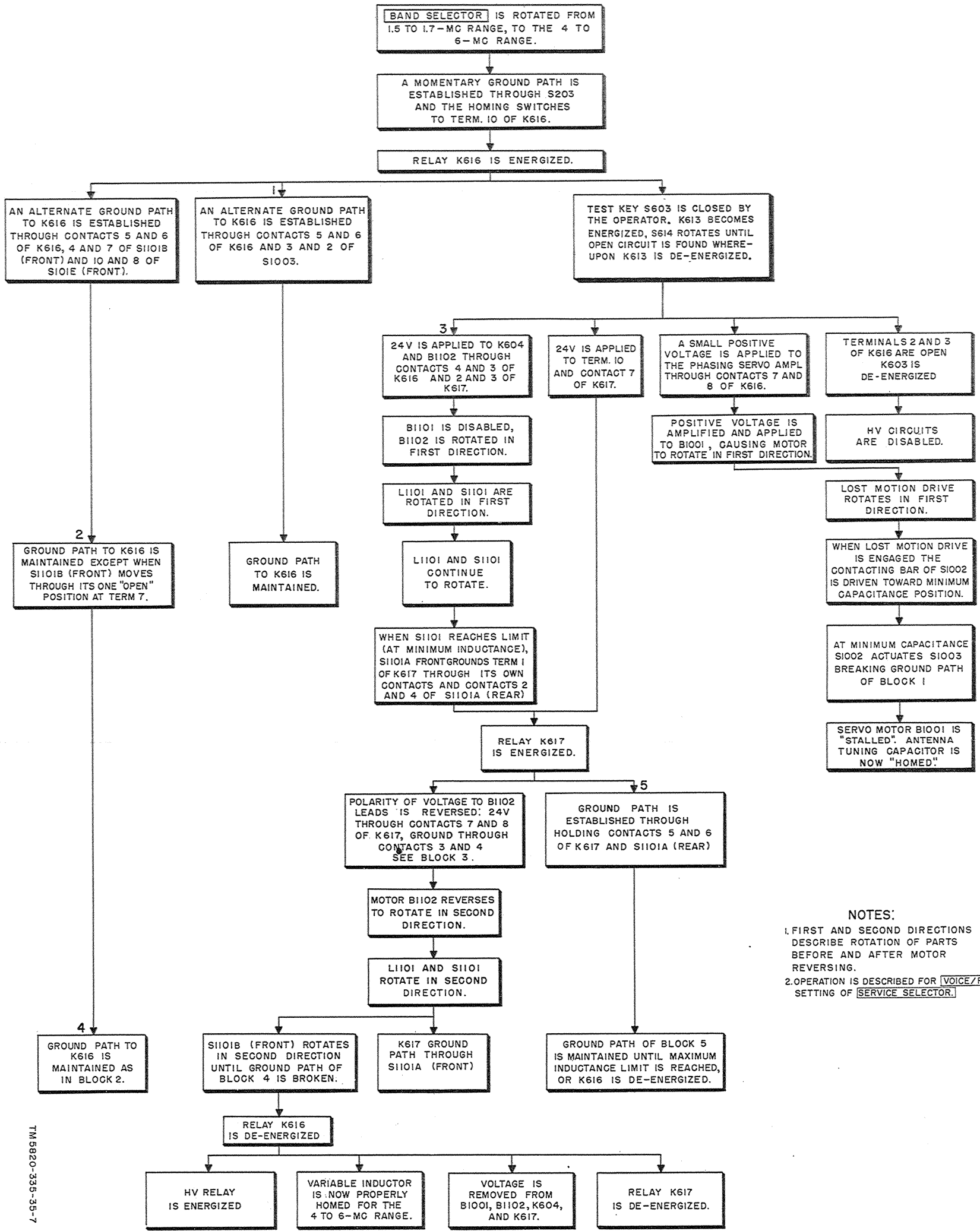

Figure 1-17. Power-amplifier plate circuit functional diagram.



**NOTES:**  
 1. FIRST AND SECOND DIRECTIONS DESCRIBE ROTATION OF PARTS BEFORE AND AFTER MOTOR REVERSING.  
 2. OPERATION IS DESCRIBED FOR [VOICE/FSK] SETTING OF [SERVICE SELECTOR].

Figure 1-30. Homing cycle flow chart.

TM5820-335-35-7

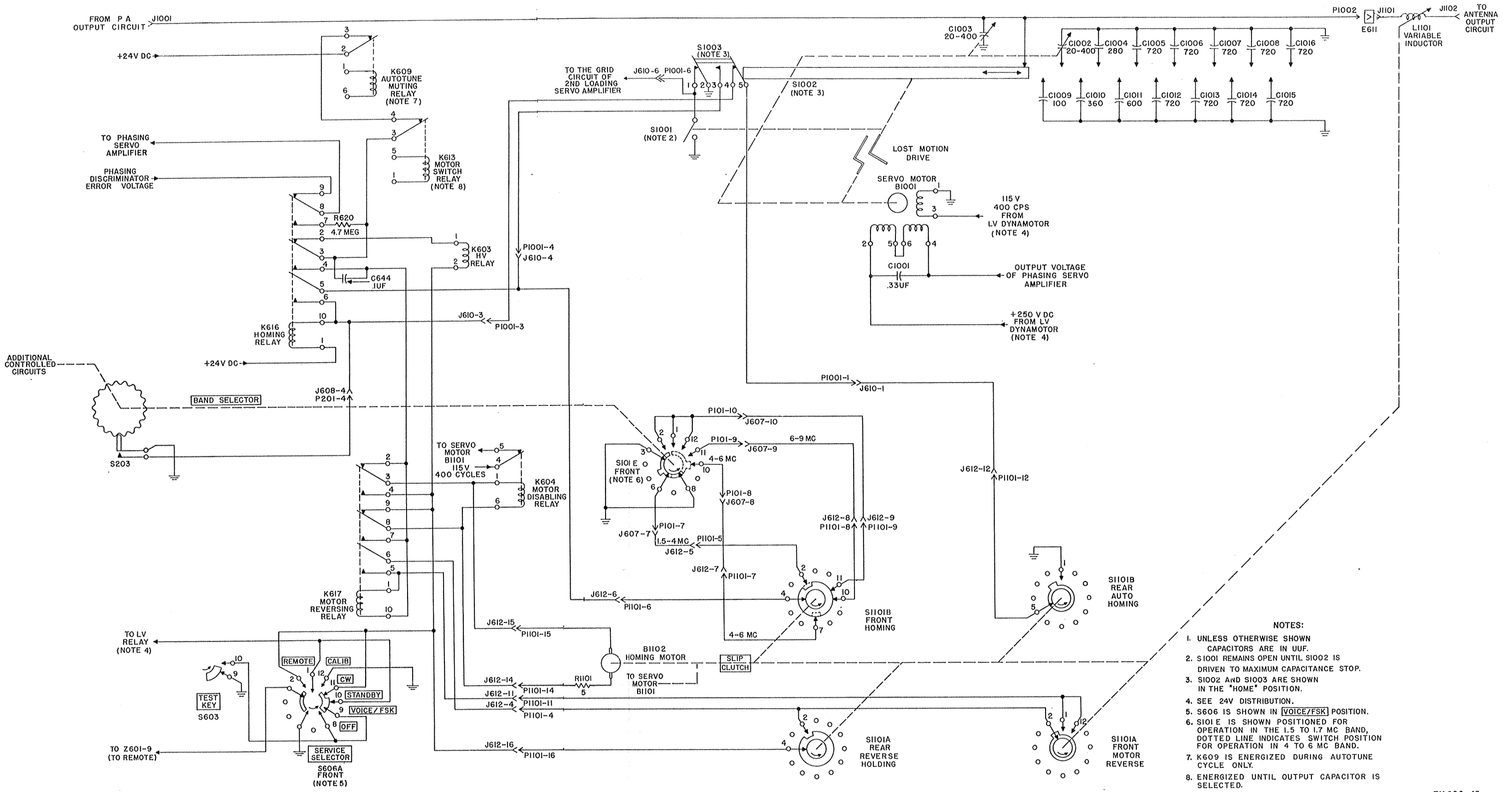

- NOTES:
1. UNLESS OTHERWISE SHOWN CAPACITORS ARE IN UUF.
  2. S1001 REMAINS OPEN UNTIL S1002 IS DRIVEN TO MAXIMUM CAPACITANCE STOP.
  3. S1002 AND S1003 ARE SHOWN IN THE "HOME" POSITION.
  4. SEE 24V DISTRIBUTION.
  5. S606 IS SHOWN IN [VOICE/FSK] POSITION.
  6. S101E IS SHOWN POSITIONED FOR OPERATION IN THE 1.5 TO 1.7 MC BAND, DOTTED LINE INDICATES SWITCH POSITION FOR OPERATION IN 4 TO 6 MC BAND.
  7. K609 IS ENERGIZED DURING AUTOTUNE CYCLE ONLY.
  8. ENERGIZED UNTIL OUTPUT CAPACITOR IS SELECTED.

Figure 1-31. Homing circuits, functional diagram.

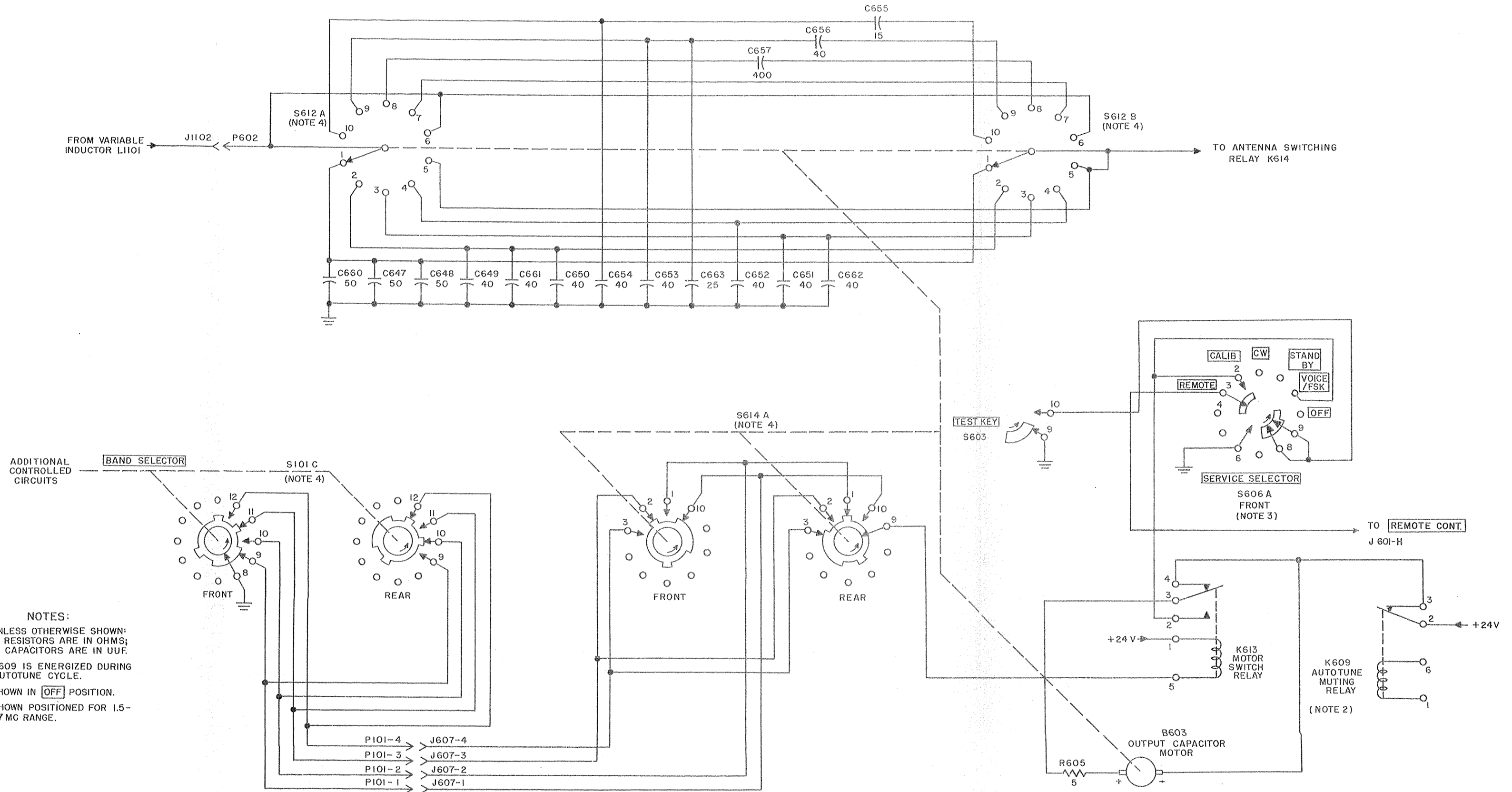

- NOTES:**
1. UNLESS OTHERWISE SHOWN: RESISTORS ARE IN OHMS; CAPACITORS ARE IN UUF.
  2. K609 IS ENERGIZED DURING AUTOTUNE CYCLE.
  3. SHOWN IN **OFF** POSITION.
  4. SHOWN POSITIONED FOR 1.5-1.7 MC RANGE.

P101-4 → J607-4  
 P101-3 → J607-3  
 P101-2 → J607-2  
 P101-1 → J607-1

Figure 1-89. Output capacitor, functional diagram.

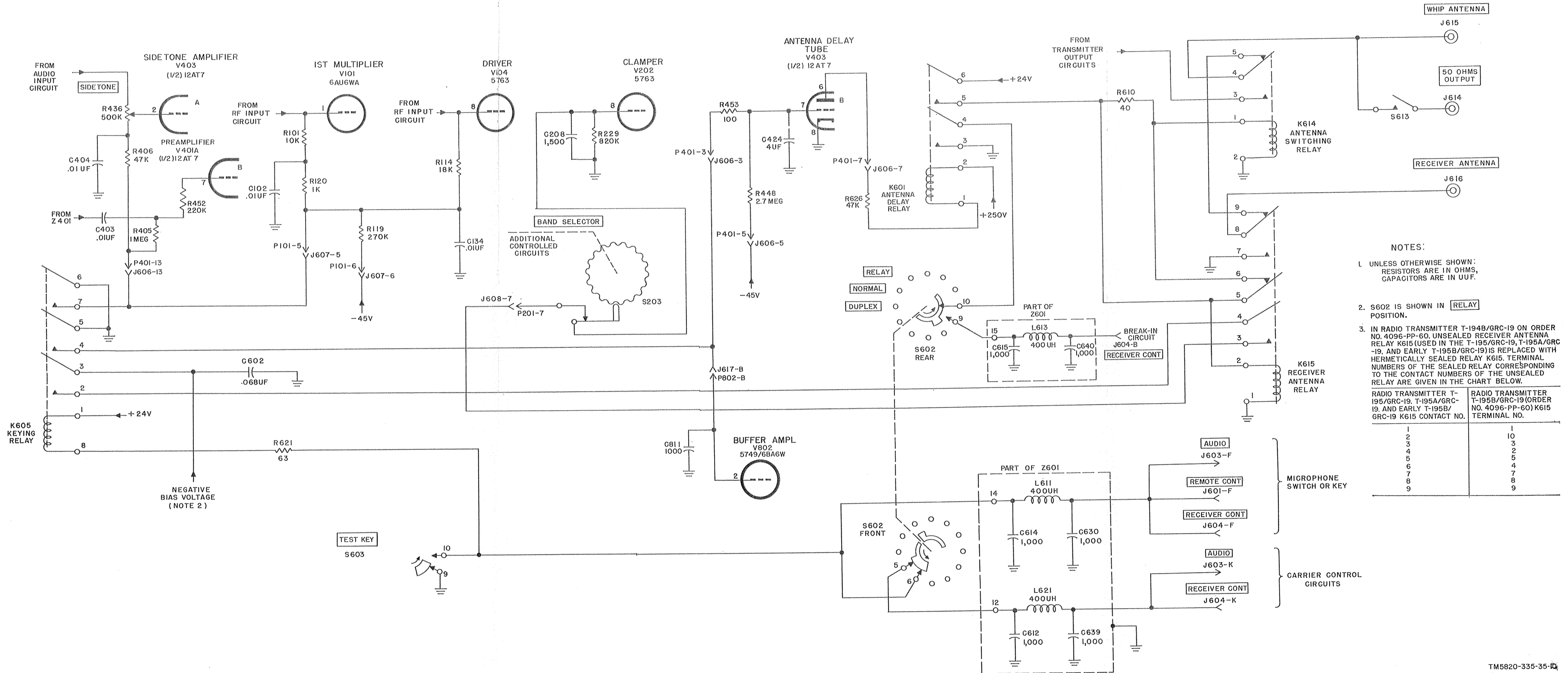

Figure 1-41. Antenna switch and keying circuits, functional diagram.

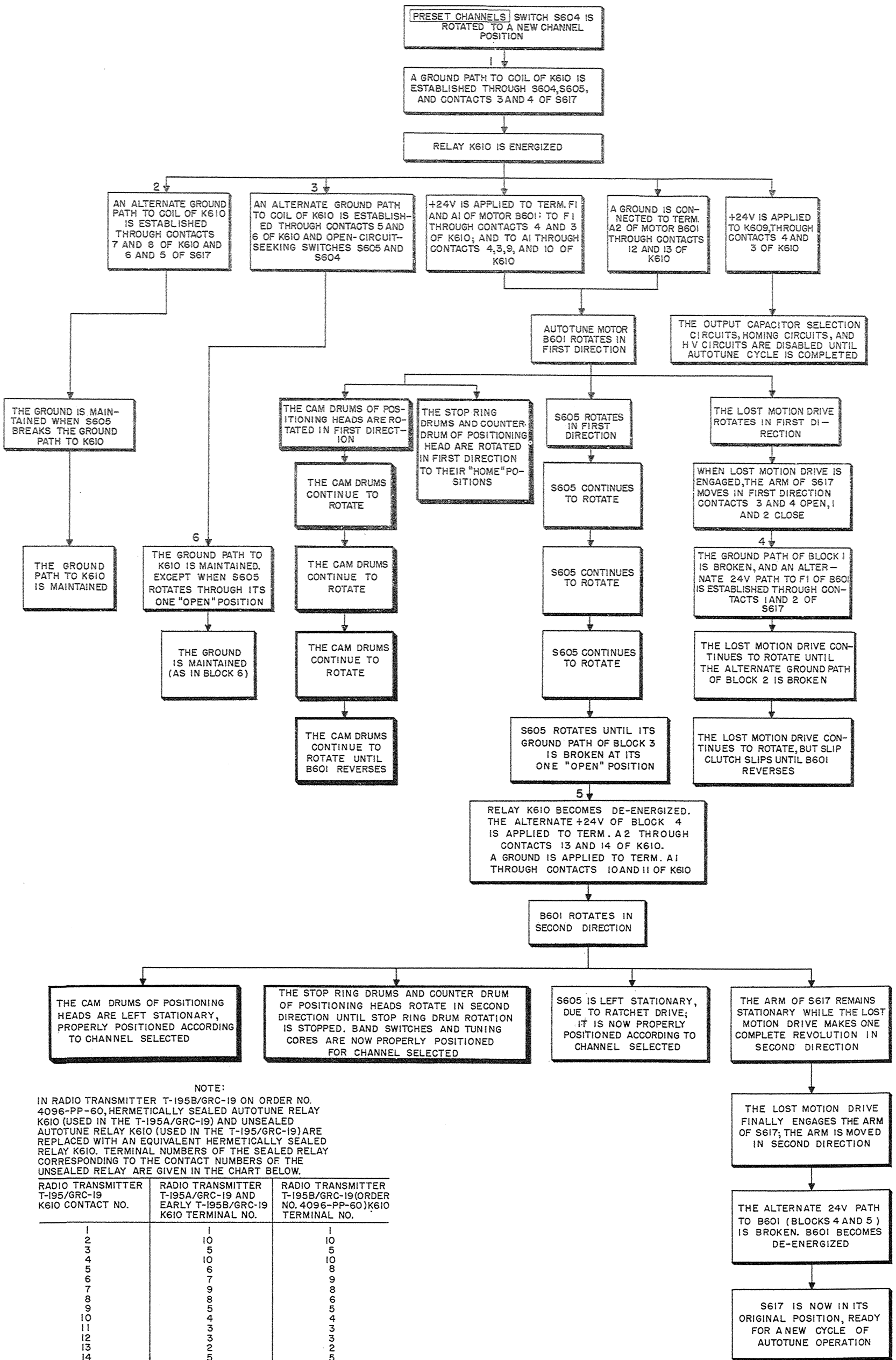
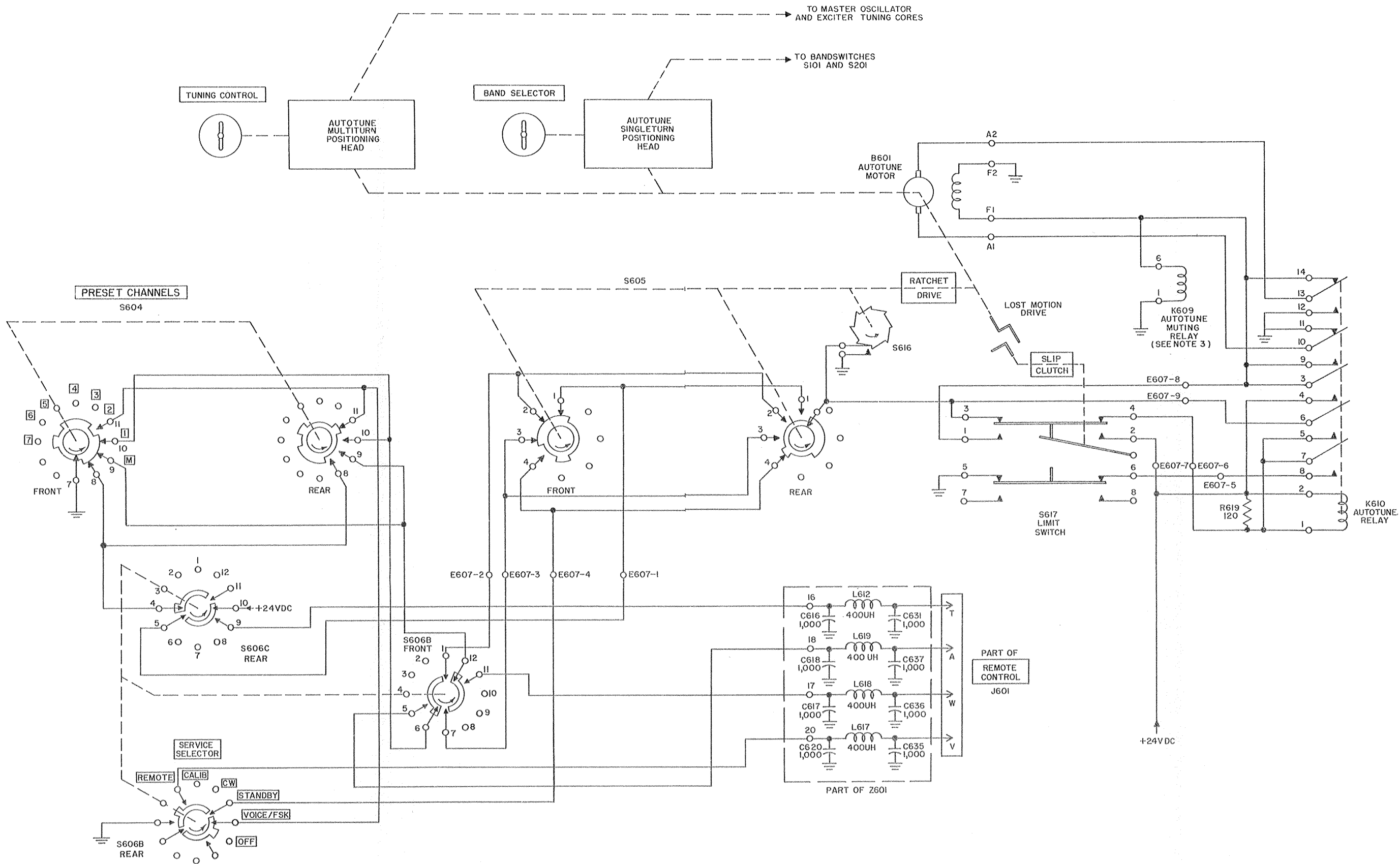

Figure 1-43. Autotune circuits, flow chart.

NOTE:

IN RADIO TRANSMITTER T-195B/GRC-19 ON ORDER NO. 4096-PP-60, HERMETICALLY SEALED AUTOTUNE RELAY K610 (USED IN THE T-195A/GRC-19) AND UNSEALED AUTOTUNE RELAY K610 (USED IN THE T-195/GRC-19) ARE REPLACED WITH AN EQUIVALENT HERMETICALLY SEALED RELAY K610. TERMINAL NUMBERS OF THE SEALED RELAY CORRESPONDING TO THE CONTACT NUMBERS OF THE UNSEALED RELAY ARE GIVEN IN THE CHART BELOW.

RADIO TRANSMITTER T-195/GRC-19 K610 CONTACT NO.	RADIO TRANSMITTER T-195A/GRC-19 AND EARLY T-195B/GRC-19 K610 TERMINAL NO.	RADIO TRANSMITTER T-195B/GRC-19 (ORDER NO. 4096-PP-60) K610 TERMINAL NO.
1	1	1
2	10	10
3	5	5
4	10	8
5	6	9
6	7	8
7	9	6
8	8	5
9	5	4
10	4	3
11	3	3
12	2	3
13	2	2
14	5	5



**NOTES:**

- S606 IS SHOWN IN **OFF** POSITION.
- S604 IS SHOWN IN **M** (MANUAL) POSITION.
- SEE +24-VOLT DISTRIBUTION.
- UNLESS OTHERWISE SHOWN: CAPACITORS ARE IN UUF.
- IN RADIO TRANSMITTER T-195B/GRC-19 ON ORDER NO. 4096-PP-60, HERMETICALLY SEALED AUTOTUNE RELAY K610 (USED IN THE T-195A/GRC-19) AND UNSEALED AUTOTUNE RELAY K610 (USED IN THE T-195/GRC-19) ARE REPLACED WITH AN EQUIVALENT HERMETICALLY SEALED RELAY K610. TERMINAL NUMBERS OF THE SEALED RELAY CORRESPONDING TO THE CONTACT NUMBERS OF THE UNSEALED RELAY ARE GIVEN IN THE CHART BELOW.

RADIO TRANSMITTER T-195/GRC-19 K610 CONTACT NO.	RADIO TRANSMITTERS T-195A/GRC-19 AND EARLY T-195B/GRC-19 K610 TERMINAL NO.	RADIO TRANSMITTER T-195B/GRC-19 (ORDER NO. 4096-PP-60) K610 TERMINAL NO.
1	10	10
2	5	5
3	10	10
4	6	6
5	7	7
6	9	8
7	8	8
8	5	5
9	5	5
10	4	4
11	3	3
12	3	3
13	3	3
14	2	2

Figure 1-44. Autotune control circuits, functional diagram.



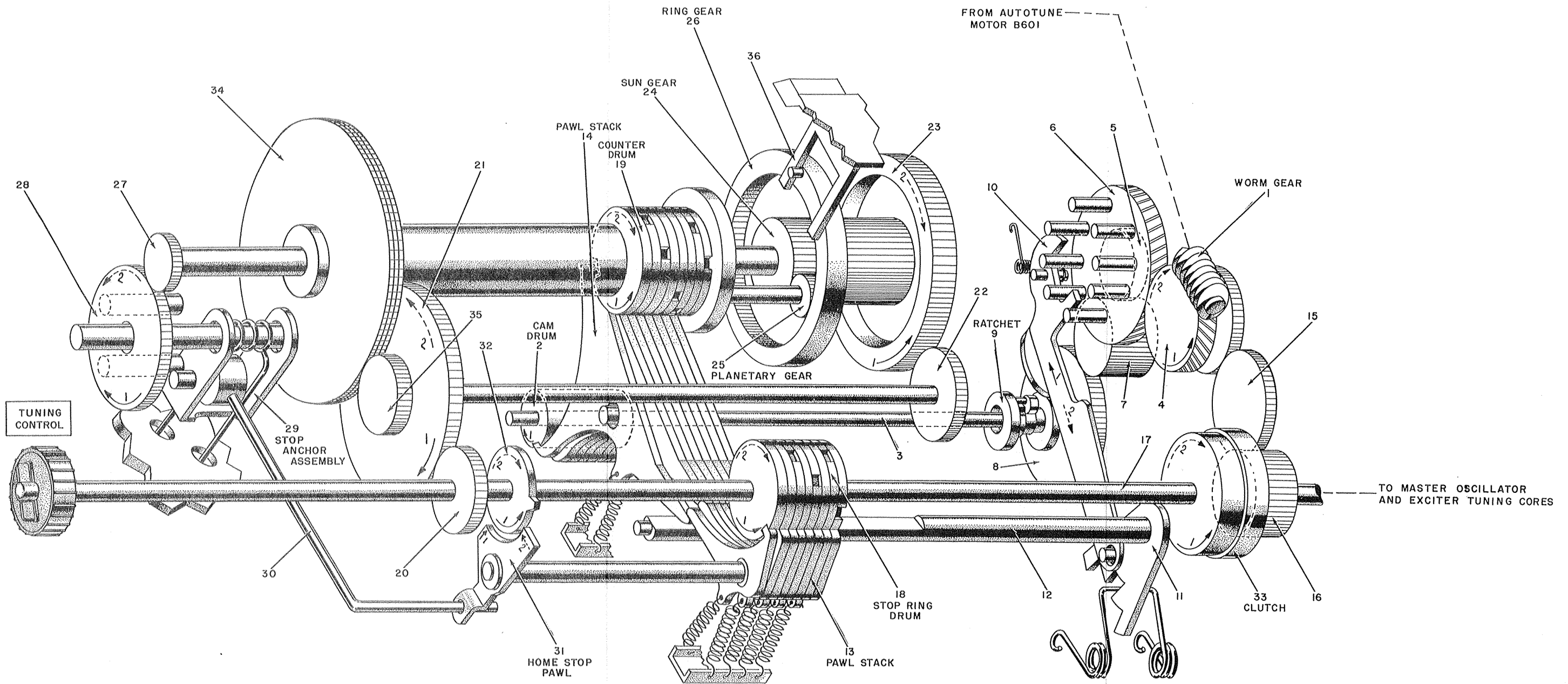

NOTE:  
 THIS IS A REPRESENTATIVE DRAWING.  
 PARTS ARE NOT NECESSARILY DRAWN  
 TO SCALE.

Figure 1-48. Multiturn positioning head, representative drawing.



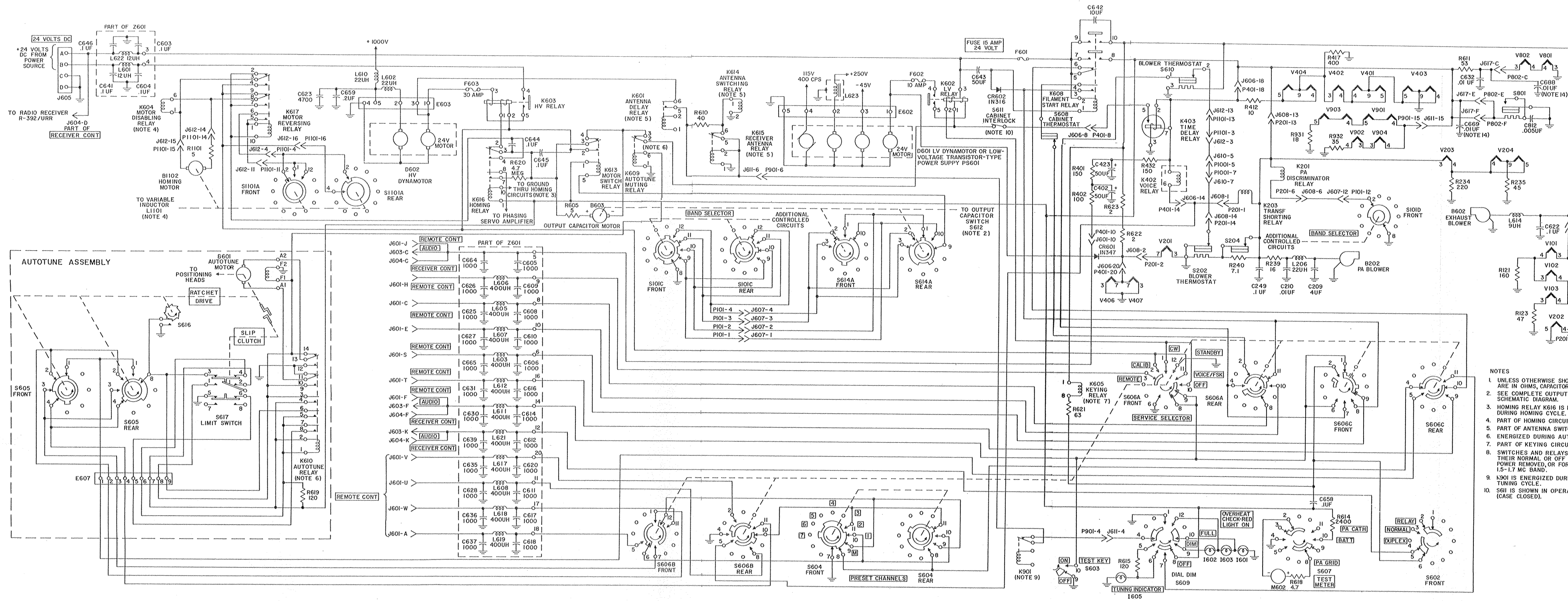

Figure 1-51. 24-volt distribution, functional diagram.

11. IN RADIO TRANSMITTER T-195B/GRC-19 ON ORDER NO. 4096-PP-60, HERMETICALLY SEALED AUTOTUNE RELAY K610 (USED IN THE T-195A/GRC-19 AND EARLY T-195B/GRC-19) AND UNSEALED AUTOTUNE RELAY K610 (USED IN THE T-195/GRC-19) ARE REPLACED WITH AN EQUIVALENT HERMETICALLY SEALED RELAY K610. TERMINAL NUMBERS OF THE SEALED RELAY CORRESPONDING TO THE CONTACT NUMBERS OF THE UNSEALED RELAY ARE GIVEN IN THE CHART BELOW.

RADIO TRANSMITTER T-195B/GRC-19 K610 CONTACT NO.	RADIO TRANSMITTER T-195A/GRC-19 AND EARLY T-195B/GRC-19 K610 TERMINAL NO.	RADIO TRANSMITTER T-195B/GRC-19 (ORDER NO. 4096-PP-60) K610 TERMINAL NO.
1	1	1
2	10	10
3	10	10
4	10	10
5	6	6
6	7	7
7	8	8
8	8	8
9	5	5
10	4	4
11	3	3
12	3	3
13	2	2
14	5	5

12. IN RADIO TRANSMITTER T-195B/GRC-19 ON ORDER NO. 4096-PP-60, UNSEALED AUTOTUNE RELAY K608 (USED IN THE T-195A/GRC-19 AND EARLY T-195B/GRC-19) IS REPLACED WITH AN EQUIVALENT HERMETICALLY SEALED RELAY K608. TERMINAL NUMBERS OF THE SEALED RELAY ARE GIVEN IN THE CHART BELOW.

RADIO TRANSMITTER T-195B/GRC-19 K608 CONTACT NO.	RADIO TRANSMITTER T-195A/GRC-19 AND EARLY T-195B/GRC-19 K608 TERMINAL NO.	RADIO TRANSMITTER T-195B/GRC-19 (ORDER NO. 4096-PP-60) K608 TERMINAL NO.
1	4	4
2	7	7
3	2	2
4	3	3
5	5	5
6	7	7
7	5	5
8	6	6
9	7	7
10	1	1
	7	7
	6	6
	1	1
	7	7
	6	6

13. IN RADIO TRANSMITTER T-194B/GRC-19 ON ORDER NO. 4096-PP-60, UNSEALED RECEIVER ANTENNA RELAY K615 (USED IN THE T-195B/GRC-19, T-195A/GRC-19, AND EARLY T-195B/GRC-19) IS REPLACED WITH AN EQUIVALENT HERMETICALLY SEALED RELAY K615. TERMINAL NUMBERS OF THE SEALED RELAY ARE GIVEN IN THE CHART BELOW.

RADIO TRANSMITTER T-195B/GRC-19 K615 CONTACT NO.	RADIO TRANSMITTER T-195A/GRC-19 AND EARLY T-195B/GRC-19 K615 TERMINAL NO.	RADIO TRANSMITTER T-195B/GRC-19 (ORDER NO. 4096-PP-60) K615 TERMINAL NO.
1	10	10
2	3	3
3	2	2
4	5	5
5	5	5
6	4	4
7	7	7
8	8	8
9	8	8
	9	9

14. ON MAIN FRAME MOD 5A AND HIGHER, CAPACITORS C668 AND C669 ARE ADDED.

- NOTES
1. UNLESS OTHERWISE SHOWN, RESISTORS ARE IN OHMS, CAPACITORS ARE IN UUF.
  2. SEE COMPLETE OUTPUT CAPACITOR SCHEMATIC DIAGRAM.
  3. HOMING RELAY K616 IS ENERGIZED DURING HOMING CYCLE.
  4. PART OF HOMING CIRCUIT.
  5. PART OF ANTENNA SWITCHING CIRCUIT.
  6. ENERGIZED DURING AUTOTUNE CYCLE.
  7. PART OF KEYING CIRCUIT.
  8. SWITCHES AND RELAYS ARE SHOWN IN THEIR NORMAL OR OFF POSITIONS, WITH POWER REMOVED, OR FOR OPERATION IN IS-1.7 MC BAND.
  9. K901 IS ENERGIZED DURING ANTENNA TUNING CYCLE.
  10. S611 IS SHOWN IN OPERATED POSITION (CASE CLOSED).

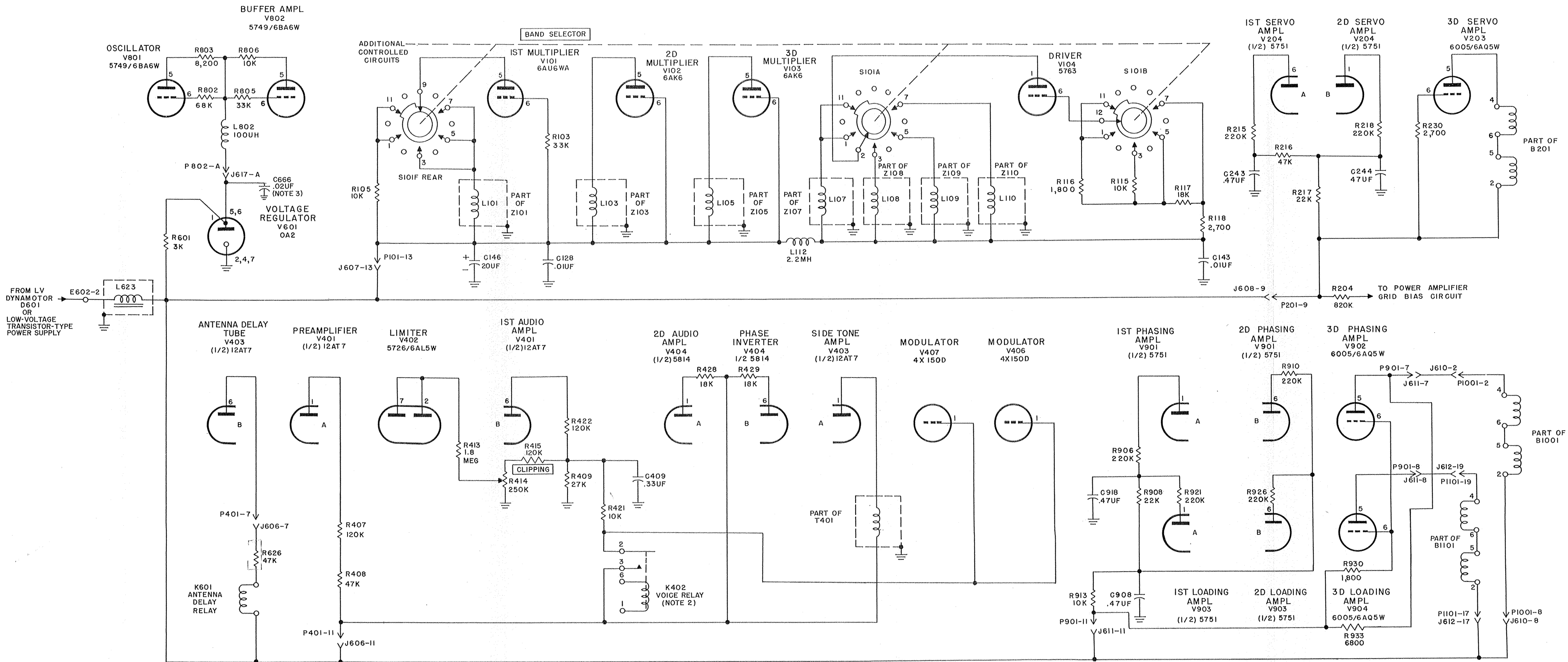

- NOTES:
1. UNLESS OTHERWISE SHOWN: RESISTORS ARE IN OHMS, CAPACITORS ARE IN UUF.
  2. K402 IS ENERGIZED IN VOICE/FSK OPERATION.
  3. ON MAIN FRAME MOD 5A AND HIGHER, CAPACITOR C666 IS ADDED.

Figure 1-55. +250-volt distribution, functional diagram.

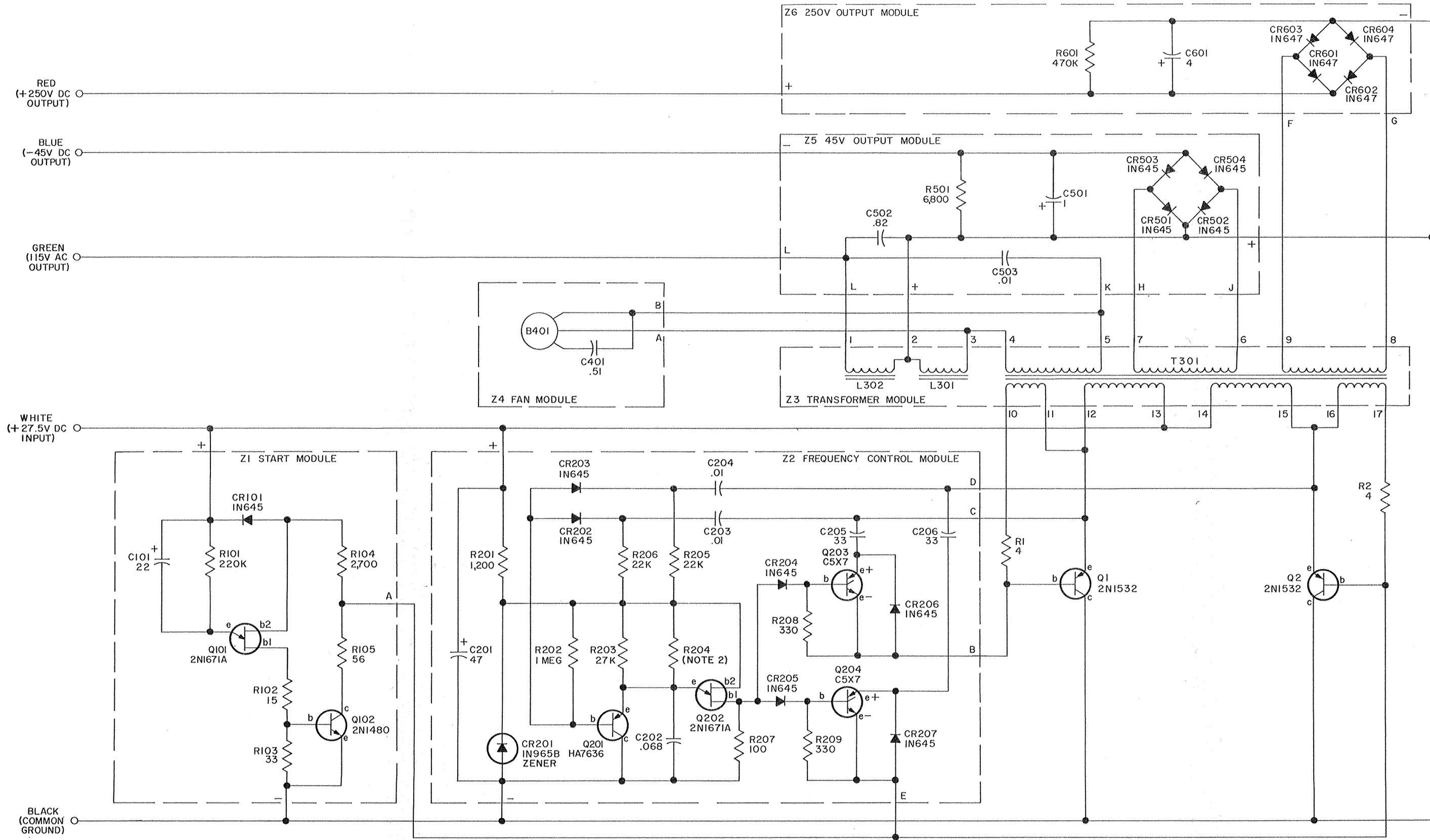

- NOTES:
1. UNLESS OTHERWISE SPECIFIED, ALL RESISTANCES ARE IN OHMS, CAPACITANCES ARE IN MICROFARADS
  2. SELECTED VALUE BETWEEN 13K AND 560K.

Figure 1-65. Low-voltage power supply PS601, schematic diagram.

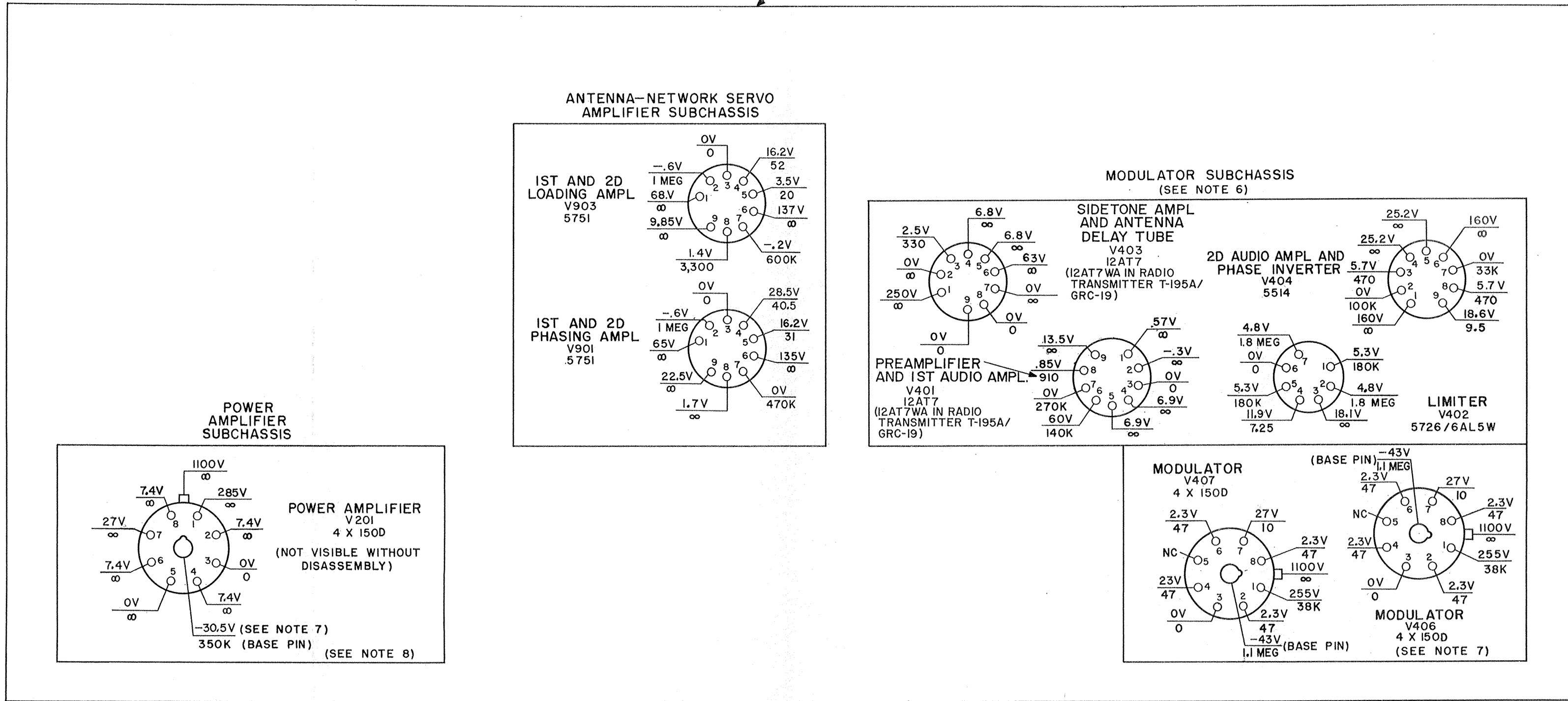

NOTES:

1. UNLESS OTHERWISE SHOWN, RESISTANCES ARE IN OHMS AND ARE MEASURED FROM SOCKET PIN TO GROUND WITH A 20,000-OHMS-PER-VOLT METER, AND WITH THE SUBCHASSIS PLUGS DISCONNECTED FROM THE MAIN FRAME. VOLTAGES ARE DC AND ARE MEASURED FROM SOCKET PIN TO GROUND WITH A VTVM AND WITH THE SUBCHASSIS CONNECTED TO MAIN FRAME USING THE REQUIRED BENCH-TEST CABLE.
2. NC INDICATES NO CONNECTION.
3. ∞ INDICATES INFINITY.
4. UNLESS OTHERWISE NOTED, ALL RESISTANCE MEASUREMENTS ARE TAKEN WITH THE SERVICE SELECTOR AT OFF, AND THE BAND SELECTOR AND TUNING CONTROL SET FOR 18,000 MC AS SHOWN ON THE FREQUENCY INDICATOR. ALL VOLTAGE MEASUREMENTS ARE TAKEN AT 18 MC WITH THE CONTROLS SET AS FOLLOWS: DIAL DIM AT FULL, TEST KEY AT ON, LINE LEVEL AT -34, RELAY-NORMAL-DUPLEX AT NORMAL, AND SERVICE SELECTOR AT CW.
5. THIS MEASUREMENT TAKEN WITH TEST KEY AT OFF.
6. VOLTAGE MEASUREMENT FOR THE MODULATOR SUBCHASSIS ARE MADE WITH SERVICE SELECTOR AT VOICE AND NO MODULATION INPUT TO THE TRANSMITTER.
7. THE MEASUREMENTS FOR THE PLATES OF V406 AND V407 ARE TAKEN AT TERMINALS 2 AND 1 RESPECTIVELY OF T402.
8. MEASUREMENTS FOR SOCKET PINS 2,5,7 AND BASE PIN OF V201 ARE TAKEN AT TERMINALS E205, E207, E206, AND E208 RESPECTIVELY LOCATED ON SHIELD NEAR SOCKET XV201.
9. ALL TUBES IN EACH SUBCHASSIS REMOVED.

Figure 2-58. Radio Transmitter T-195/GRC-19, bottom deck, tube and resistance diagram.

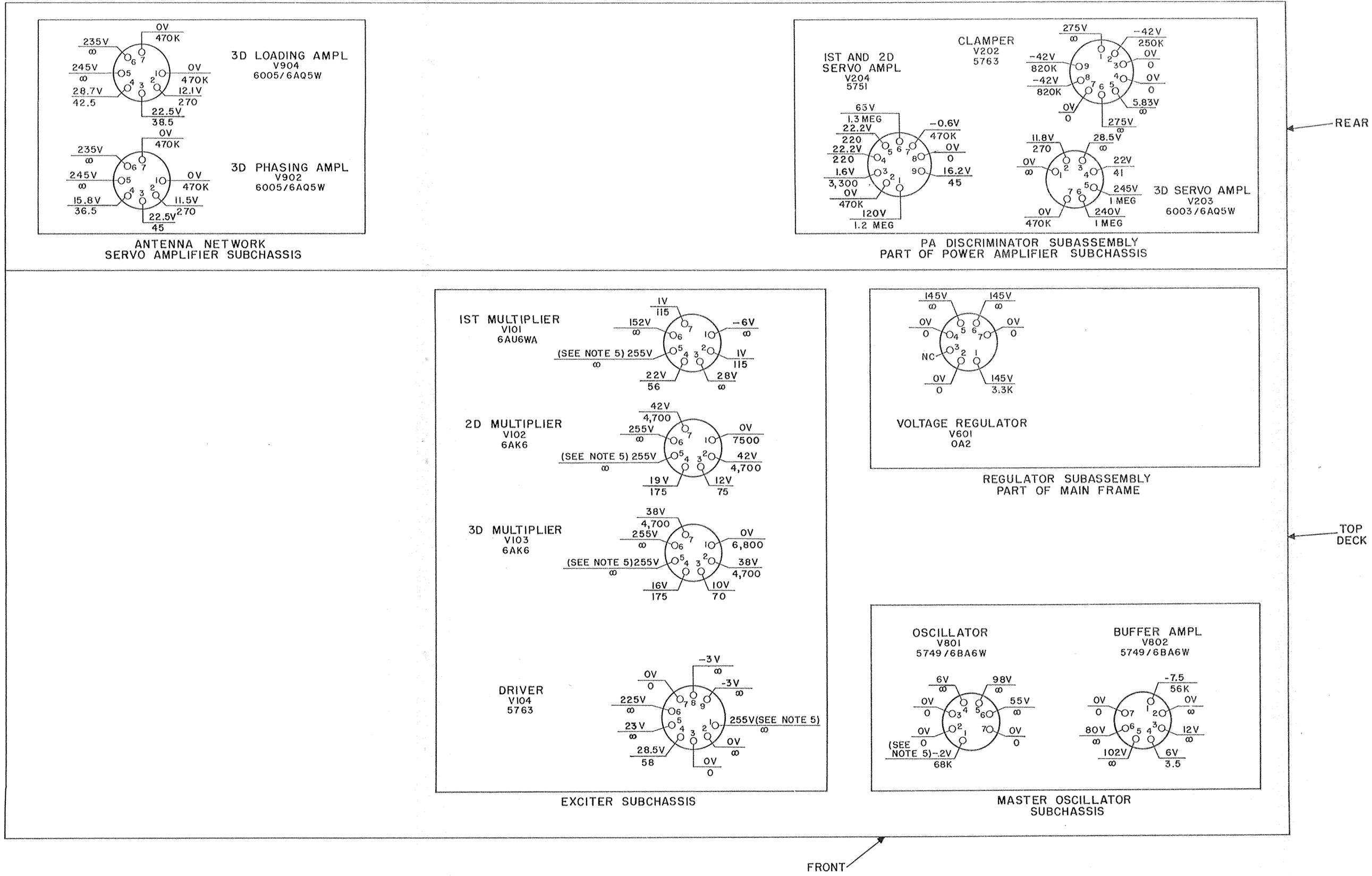

- NOTES:
1. UNLESS OTHERWISE SHOWN, RESISTANCES ARE IN OHMS AND ARE MEASURED FROM SOCKET PIN TO GROUND WITH A 20,000-OHMS-PER-VOLT METER AND WITH THE SUBCHASSIS PLUGS DISCONNECTED FROM THE MAIN FRAME. VOLTAGES ARE DC AND ARE MEASURED FROM SOCKET PIN TO GROUND WITH A VTVM AND WITH SUBCHASSIS CONNECTED TO MAIN FRAME, USING THE REQUIRED BENCH-TEST CABLE.
  2. NC INDICATES NO CONNECTION.
  3. ∞ INDICATES INFINITY.
  4. UNLESS OTHERWISE NOTED, ALL RESISTANCE MEASUREMENTS ARE TAKEN WITH THE SERVICE SELECTOR AT OFF, AND THE BAND SELECTOR AND TUNING CONTROL SET FOR 18.000 MC AS SHOWN ON THE FREQUENCY INDICATOR. ALL VOLTAGE MEASUREMENTS ARE TAKEN AT 18 MC WITH THE CONTROL SET AS FOLLOWS: DIAL DIM AT FULL, TEST KEY AT ON, LINE LEVEL AT -34, RELAY-NORMAL-DUPLEX AT NORMAL, AND SERVICE SELECTOR AT CW.
  5. THIS MEASUREMENT TAKEN WITH TEST KEY AT OFF.
  6. ALL TUBES IN EACH SUBCHASSIS REMOVED.

Figure 2-57. Radio Transmitter T-195/GRC-19, top deck, tube and resistance diagram.



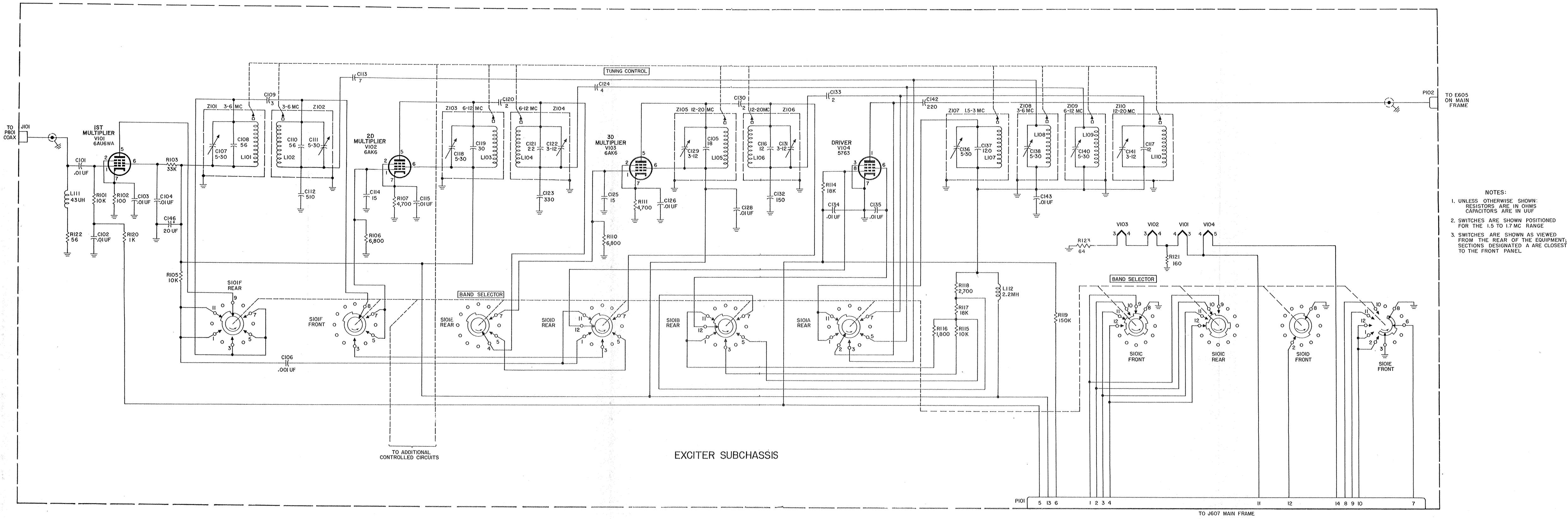

- NOTES:
1. UNLESS OTHERWISE SHOWN: RESISTORS ARE IN OHMS CAPACITORS ARE IN UUF
  2. SWITCHES ARE SHOWN POSITIONED FOR THE 1.5 TO 1.7 MC RANGE
  3. SWITCHES ARE SHOWN AS VIEWED FROM THE REAR OF THE EQUIPMENT; SECTIONS DESIGNATED A ARE CLOSEST TO THE FRONT PANEL

Figure 2-73. Exciter subchassis, schematic diagram.

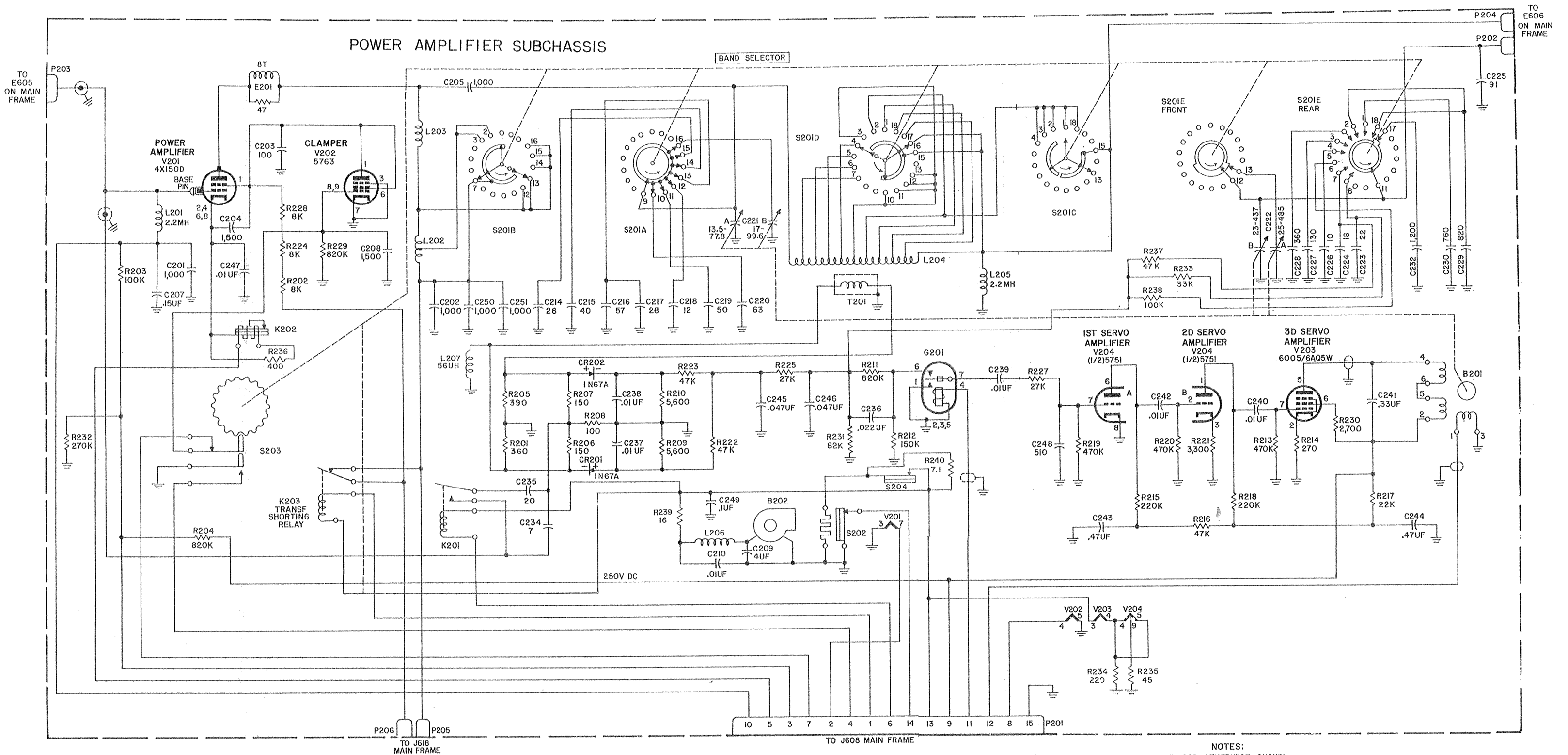

- NOTES:  
 1. UNLESS OTHERWISE SHOWN:  
 RESISTORS ARE IN OHMS,  
 CAPACITORS ARE IN UUF.  
 2. S201 IS SHOWN AS VIEWED FROM  
 REAR OF EQUIPMENT AND POSITIONED  
 FOR THE 1.5 TO 1.7 MC RANGE

Figure 2-74. Power amplifier subchassis, schematic diagram.

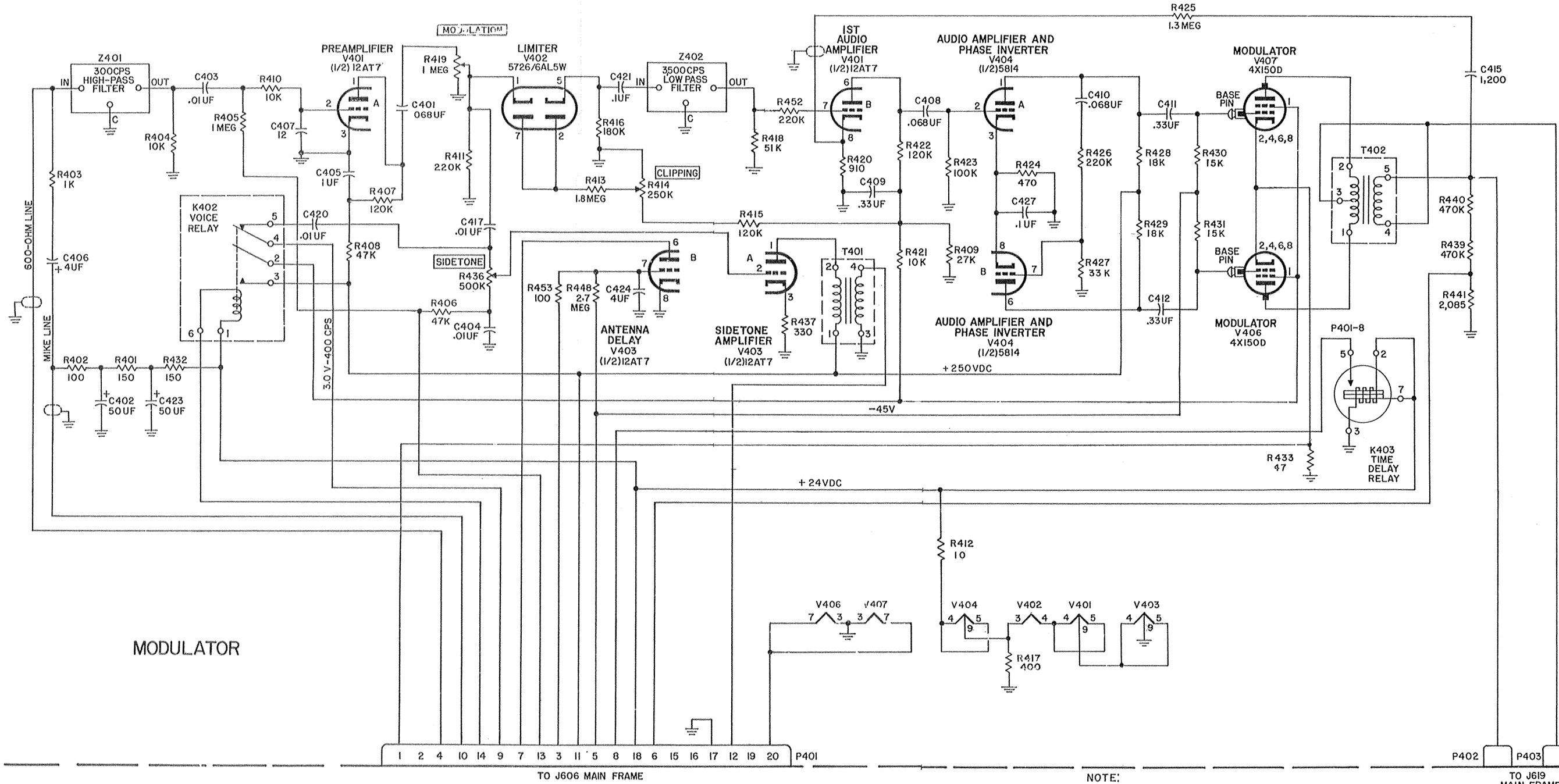

MODULATOR

NOTE:  
UNLESS OTHERWISE SHOWN:  
RESISTORS ARE IN OHMS,  
CAPACITORS ARE IN UUF.

Figure 2-75. Modulator subchassis, schematic diagram.



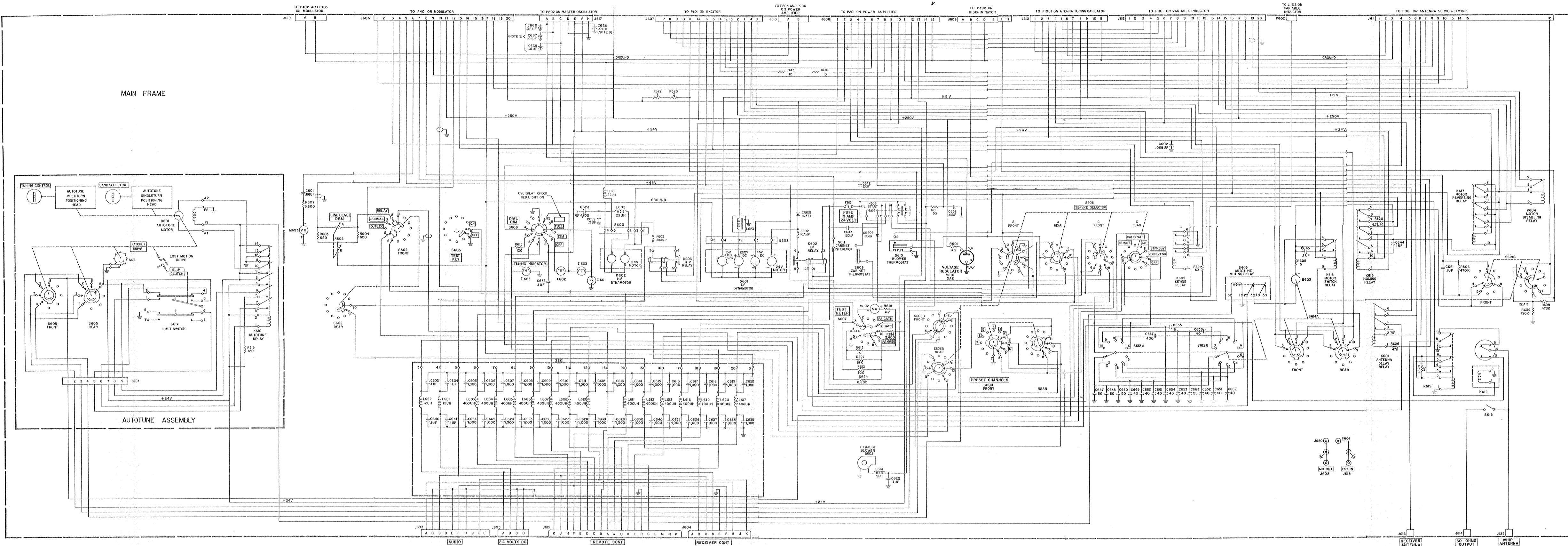

- NOTES:**
- UNLESS OTHERWISE SHOWN: RESISTORS ARE IN OHMS, CAPACITORS ARE IN MFD.
  - ALL SWITCHES ARE VIEWED FROM THE REAR OF THE EQUIPMENT.
  - SWITCHES ARE SHOWN IN THEIR FULL COUNTERCLOCKWISE POSITIONS, OR POSITIONED FOR THE 1.5 TO 1.7 MC RANGE.
  - RELAYS ARE SHOWN IN THEIR NORMAL POSITIONS WITH POWER REMOVED.
  - IN RADIO TRANSMITTER T-195B/GRC-19 ON ORDER NO. 4096-PP-60, HERMETICALLY SEALED AUTOTUNE RELAY K600 USED IN THE T-195A/GRC-19 AND EARLY T-195B/GRC-19 IS REPLACED WITH AN EQUIVALENT HERMETICALLY SEALED RELAY K601. TERMINAL NUMBERS OF THE SEALED RELAY CORRESPONDING TO THE CONTACT NUMBERS OF THE UNSEALED RELAY ARE GIVEN IN THE CHART BELOW.
 

RADIO TRANSMITTER T-195A/GRC-19 K600 CONTACT NO.	RADIO TRANSMITTER EARLY T-195A/GRC-19 K601 K610 TERMINAL NO.	RADIO TRANSMITTER T-195B/GRC-19 (ORDER NO. 4096-PP-60) K610 TERMINAL NO.
1	1	1
2	2	2
3	3	3
4	4	4
5	5	5
6	6	6
7	7	7
8	8	8
9	9	9
10	10	10
11	11	11
12	12	12
13	13	13
14	14	14
  - IN RADIO TRANSMITTER T-195B/GRC-19 ON ORDER NO. 4096-PP-60, UNSEALED AUTOTUNE RELAY K600 USED IN THE T-195A/GRC-19 AND EARLY T-195B/GRC-19 IS REPLACED WITH AN EQUIVALENT HERMETICALLY SEALED RELAY K602. TERMINAL NUMBERS OF THE SEALED RELAY CORRESPONDING TO THE CONTACT NUMBERS OF THE UNSEALED RELAY ARE GIVEN IN THE CHART BELOW.
 

RADIO TRANSMITTER T-195A/GRC-19 K608 CONTACT NO.	RADIO TRANSMITTER EARLY T-195A/GRC-19 K608 TERMINAL NO.	RADIO TRANSMITTER T-195B/GRC-19 (ORDER NO. 4096-PP-60) K602 TERMINAL NO.
1	1	1
2	2	2
3	3	3
4	4	4
5	5	5
6	6	6
7	7	7
8	8	8
9	9	9
10	10	10
  - IN RADIO TRANSMITTER T-195B/GRC-19 ON ORDER NO. 4096-PP-60, UNSEALED LV RELAY K602 (USED IN THE T-195A/GRC-19) IS REPLACED WITH HERMETICALLY SEALED RELAY K602. TERMINAL DESIGNATIONS OF THE SEALED RELAY CORRESPONDING TO THE CONTACT NUMBERS OF THE UNSEALED RELAY ARE GIVEN IN THE CHART BELOW.
 

RADIO TRANSMITTER T-195A/GRC-19 (ORDER NO. 4096-PP-60) K602 CONTACT NO.	RADIO TRANSMITTER T-195B/GRC-19 (ORDER NO. 4096-PP-60) K602 TERMINAL NO.
1	1
2	2
3	3
4	4
5	5
  - IN RADIO TRANSMITTER T-195B/GRC-19 ON ORDER NO. 4096-PP-60, UNSEALED ANTENNA RELAY K615 (USED IN THE T-195A/GRC-19 AND EARLY T-195B/GRC-19) IS REPLACED WITH HERMETICALLY SEALED RELAY K615. TERMINAL NUMBERS OF THE SEALED RELAY CORRESPONDING TO THE CONTACT NUMBERS OF THE UNSEALED RELAY ARE GIVEN IN THE CHART BELOW.
 

RADIO TRANSMITTER T-195A/GRC-19 (ORDER NO. 4096-PP-60) K615 CONTACT NO.	RADIO TRANSMITTER T-195B/GRC-19 (ORDER NO. 4096-PP-60) K615 TERMINAL NO.
1	1
2	2
3	3
4	4
5	5
6	6
7	7
8	8
9	9
  - ON MAIN FRAME MOD 5A AND HIGHER, CAPACITORS C666, C667, C668 AND C669 ARE ADDED.
 

TERMINAL	TERMINAL
1	1
2	2
3	3
4	4
5	5
6	6
7	7
8	8
9	9

Figure 2-80. Main frame schematic diagram.

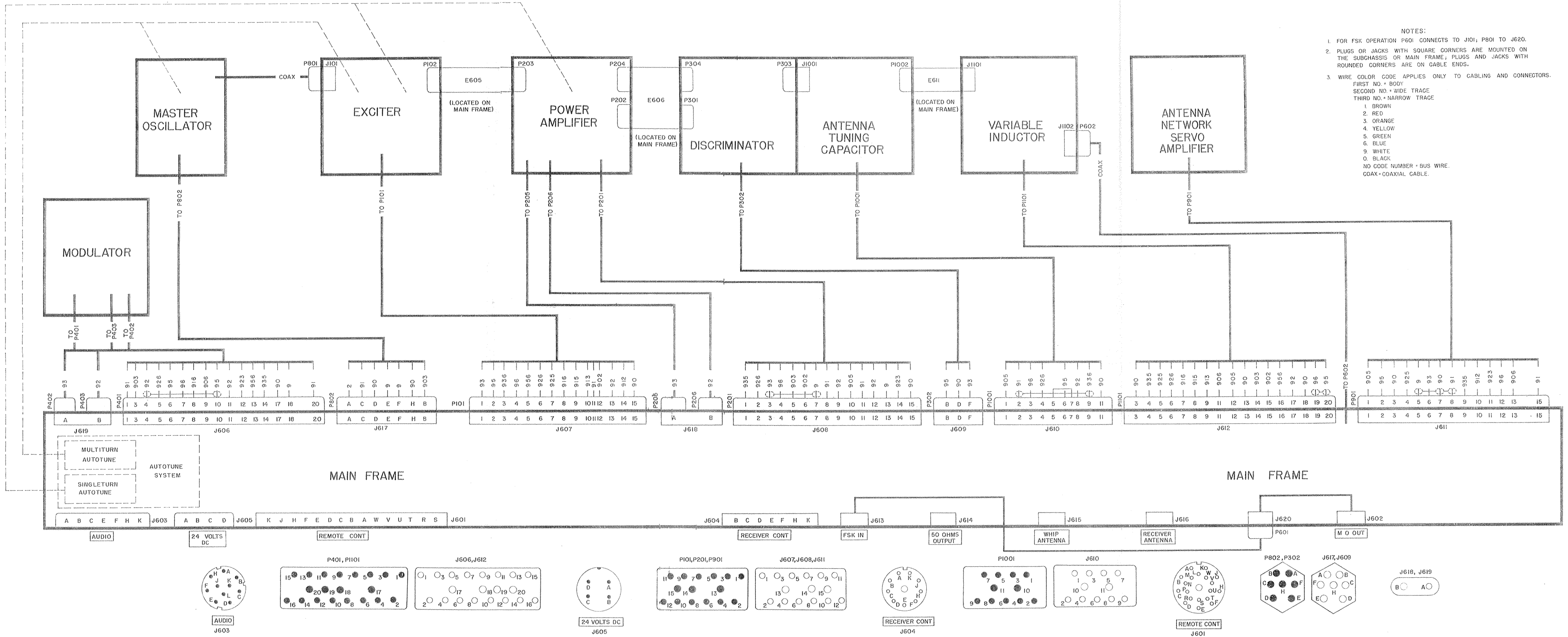

Figure 2-81. Subchassis interconnection, cabling diagram.



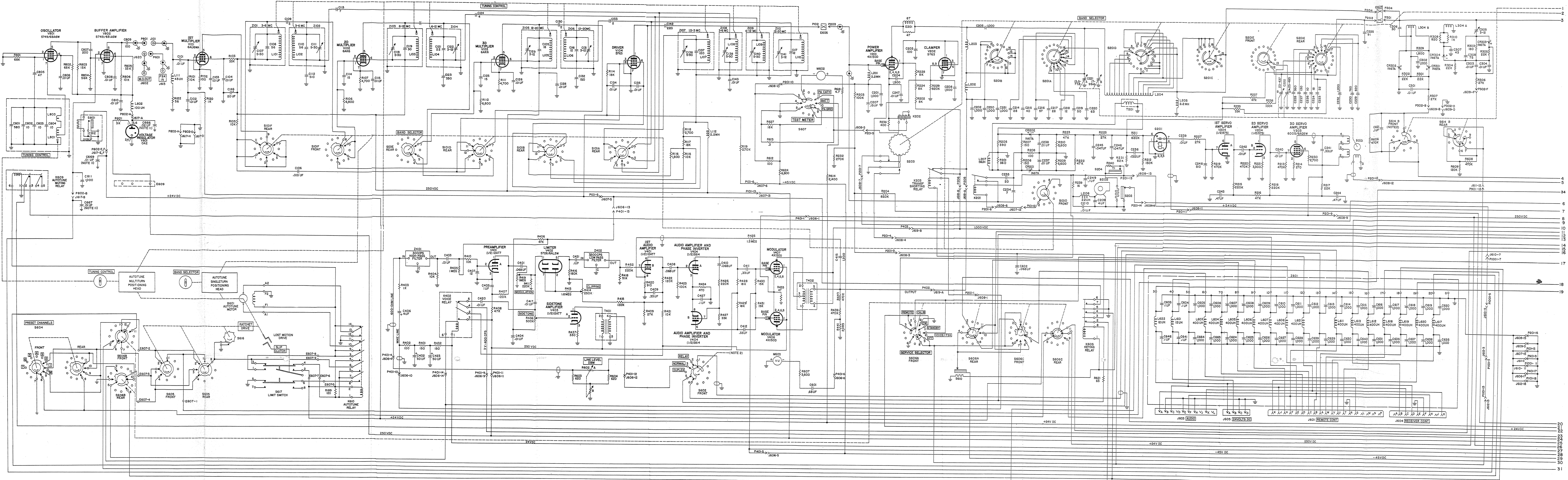
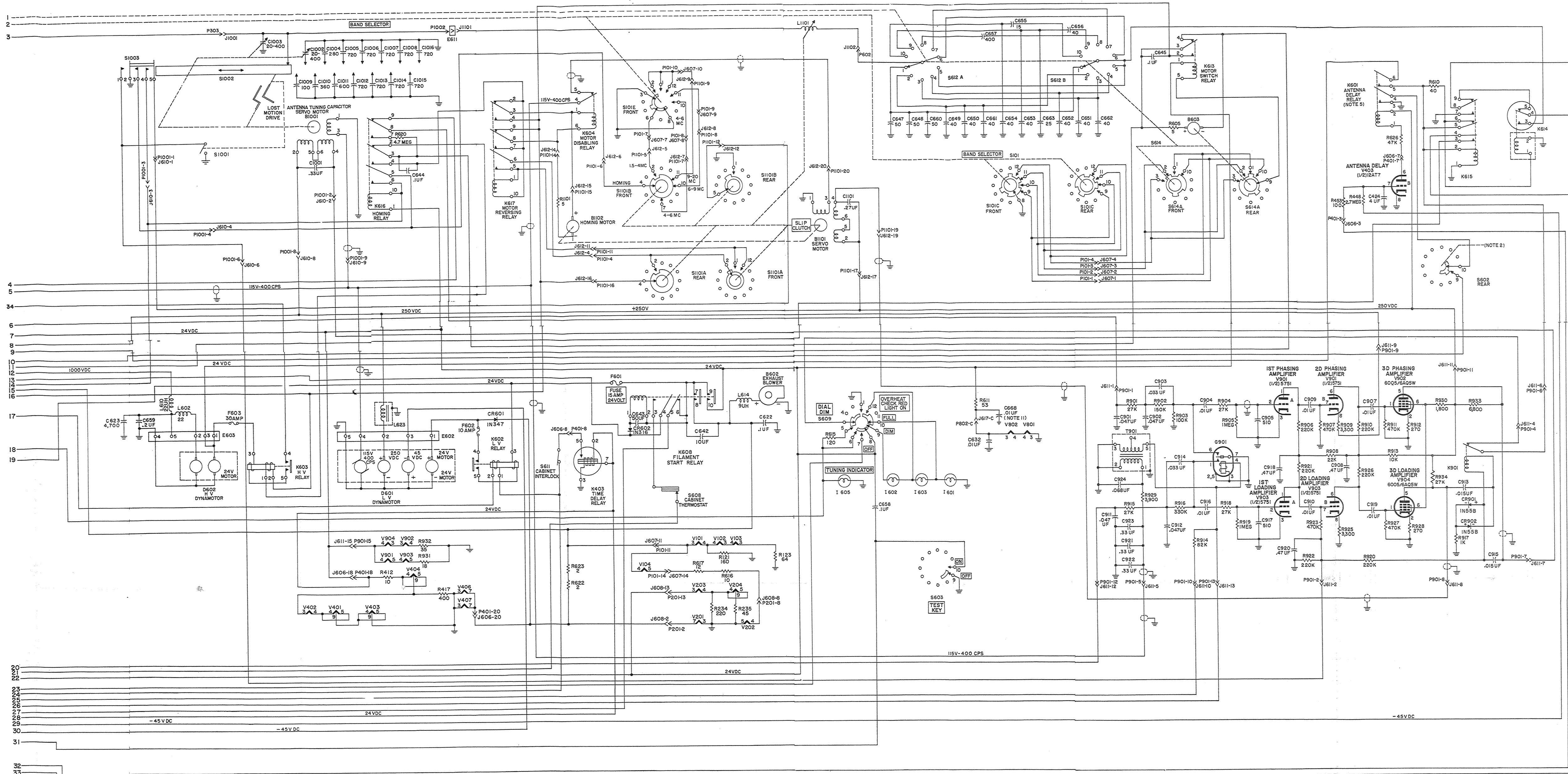

Figure 2-52.(1) Radio Transmitter T-195/GRC-19 schematic diagram.





THE FOLLOWING LEGEND IDENTIFIES RECEPTACLE CONTACTS.

RECEPTACLE CONTACT	FUNCTION	RECEPTACLE CONTACT	FUNCTION
J601 K	TUNING INDICATOR	J603 A	600-OHM LINE
J J	MICROPHONE	B	GROUND
H	L-V DYNAMOTOR START	C	MICROPHONE
F	KEY OR MICROPHONE SWITCH	E	GROUND
E	FSK RELAY CONTROL	F	KEY OR MICROPHONE SWITCH
D	SERVICE SELECTOR SW CONTROL +24V	H	GROUND
C	SERVICE SELECTOR SW CONTROL GND	K	CARRIER CONTROL
B	600-OHM LINE	J604 B	BREAK-IN CIRCUIT
A	AUTOTUNE CONTROL	C	MICROPHONE
V	AUTOTUNE CONTROL	D	+24V
W	AUTOTUNE CONTROL	E	GROUND
U	VOICE RELAY	F	KEY OR MICROPHONE
T	AUTOTUNE CONTROL	H	600-OHM LINE
R	GROUND	K	CARRIER CONTROL
S	FILAMENT START RELAY	J605 A	+24V
		B	+24V
		C	GROUND
		D	GROUND

UNLESS OTHERWISE SHOWN: RESISTORS ARE IN OHMS; CAPACITORS ARE IN UF.

2. 602 FRONT AND REAR SECTIONS ARE SEPARATED FOR SCHEMATIC PURPOSES.

3. ALL SWITCHES ARE VIEWED FROM THE REAR OF THE EQUIPMENT. SECTIONS DESIGNATED A ARE CLOSEST TO THE FRONT PANEL.

4. ALL SWITCHES ARE SHOWN IN THEIR OFF OR COUNTERCLOCKWISE POSITION, AS VIEWED FROM THE FRONT PANEL, OR POSITIONED FOR 1.5 TO 1.7 MC RANGE.

5. ALL SWITCHES AND RELAYS ARE SHOWN IN THEIR NORMAL POSITION WITH POWER REMOVED.

6. THE PHYSICAL LOCATION OF COMPONENTS CAN BE DETERMINED FROM THE FOLLOWING SYMBOL GROUPS:

SUBCHASSIS	600
EXCITER	100
POWER AMPLIFIER	200
DISCRIMINATOR	300
MODULATOR	400
MAIN FRAME AND FRONT PANEL	500
MASTER OSCILLATOR	600
ANTENNA NETWORK SERVO	800
ANTENNA TUNING CAPACITOR	1000
VARIABLE INDUCTOR	1100

NOTES:

7. IN RADIO TRANSMITTER T-195B/GRC-19 ON ORDER NO. 4096-PP-60, HERMETICALLY SEALED AUTOTUNE RELAY K602 (USED IN THE T-195/GRC-19 AND EARLY T-195B/GRC-19) IS REPLACED WITH AN EQUIVALENT HERMETICALLY SEALED RELAY K602. TERMINAL NUMBERS OF THE SEALED RELAY CORRESPONDING TO THE CONTACT NUMBERS OF THE UNSEALED RELAY ARE GIVEN IN THE CHART BELOW.

8. IN RADIO TRANSMITTER T-195/GRC-19 ON ORDER NO. 4096-PP-60, HERMETICALLY SEALED AUTOTUNE RELAY K602 (USED IN THE T-195/GRC-19 AND EARLY T-195B/GRC-19) IS REPLACED WITH AN EQUIVALENT HERMETICALLY SEALED RELAY CORRESPONDING TO THE CONTACT NUMBERS OF THE UNSEALED RELAY ARE GIVEN IN THE CHART BELOW.

9. IN RADIO TRANSMITTER T-195B/GRC-19 ON ORDER NO. 4096-PP-60, HERMETICALLY SEALED AUTOTUNE RELAY K602 (USED IN THE T-195/GRC-19 AND EARLY T-195B/GRC-19) IS REPLACED WITH AN EQUIVALENT HERMETICALLY SEALED RELAY CORRESPONDING TO THE CONTACT NUMBERS OF THE UNSEALED RELAY ARE GIVEN IN THE CHART BELOW.

10. IN RADIO TRANSMITTER T-195B/GRC-19 ON ORDER NO. 4096-PP-60, UNSEALED AUTOTUNE RELAY K602 (USED IN THE T-195/GRC-19 AND EARLY T-195B/GRC-19) IS REPLACED WITH AN EQUIVALENT HERMETICALLY SEALED RELAY K602. TERMINAL NUMBERS OF THE SEALED RELAY CORRESPONDING TO THE CONTACT NUMBERS OF THE UNSEALED RELAY ARE GIVEN IN THE CHART BELOW.

11. ON MAIN FRAME MOD 5A AND HIGHER, CAPACITORS C666, C667, C668 AND C669 ARE ADDED.

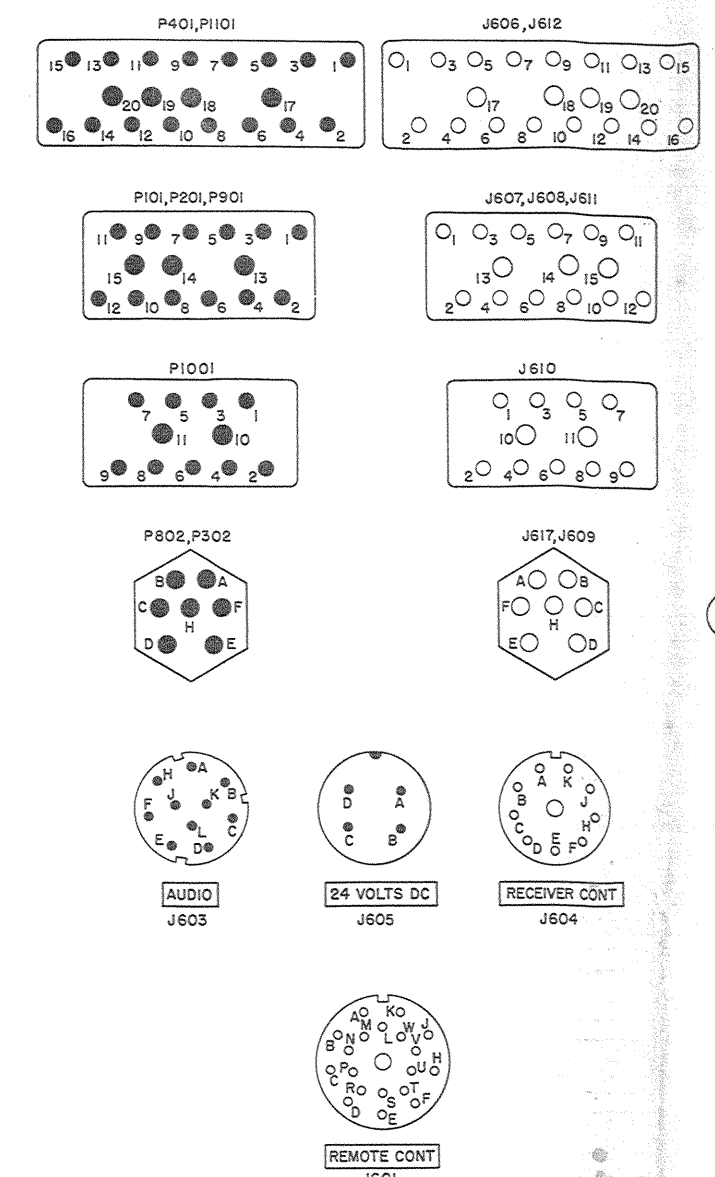

Figure 2-82.(2) Radio Transmitter T-195/GRC-19 schematic diagram.

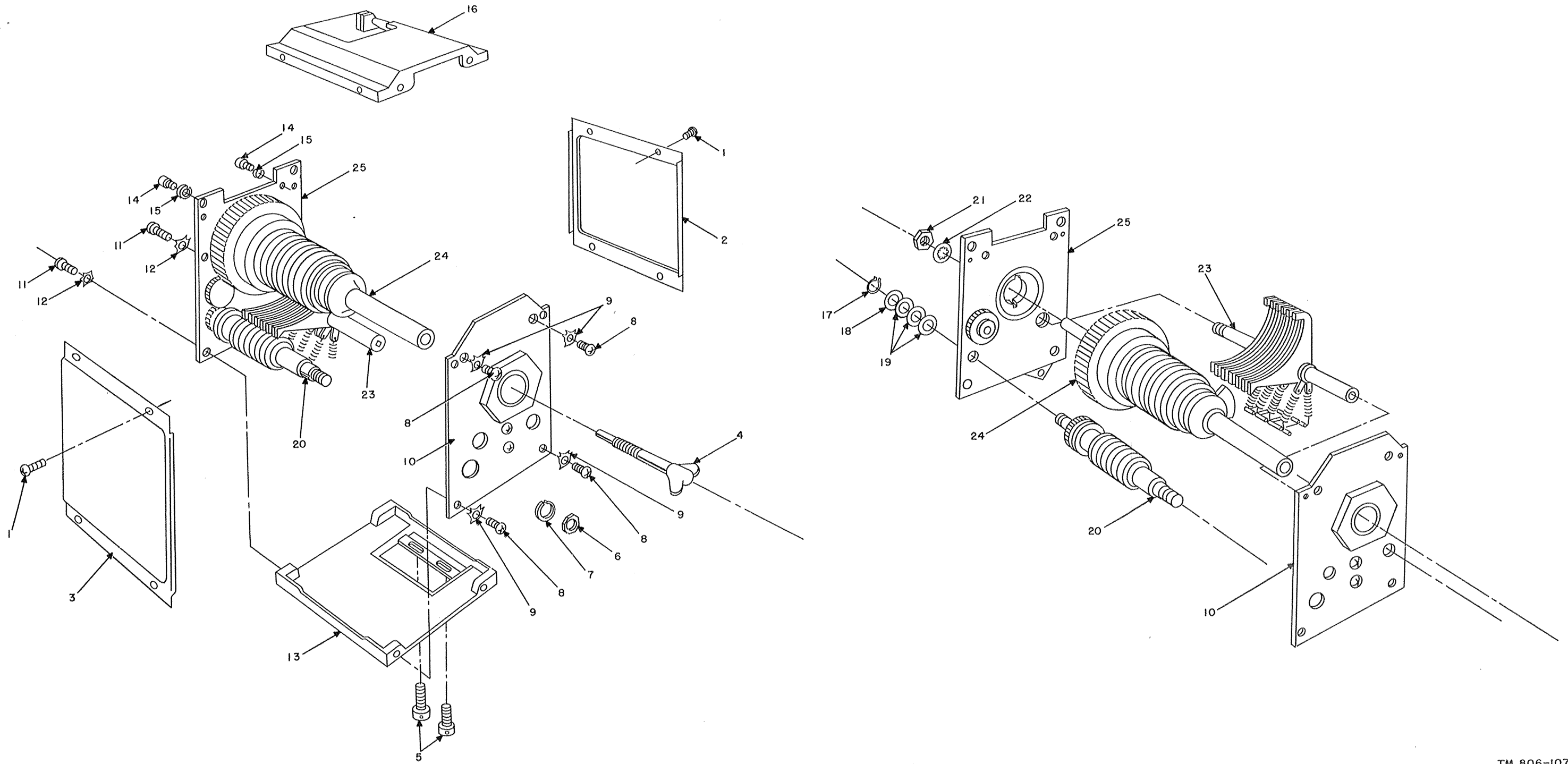

Figure 3-2. Disassembly of autotune singleturn head.

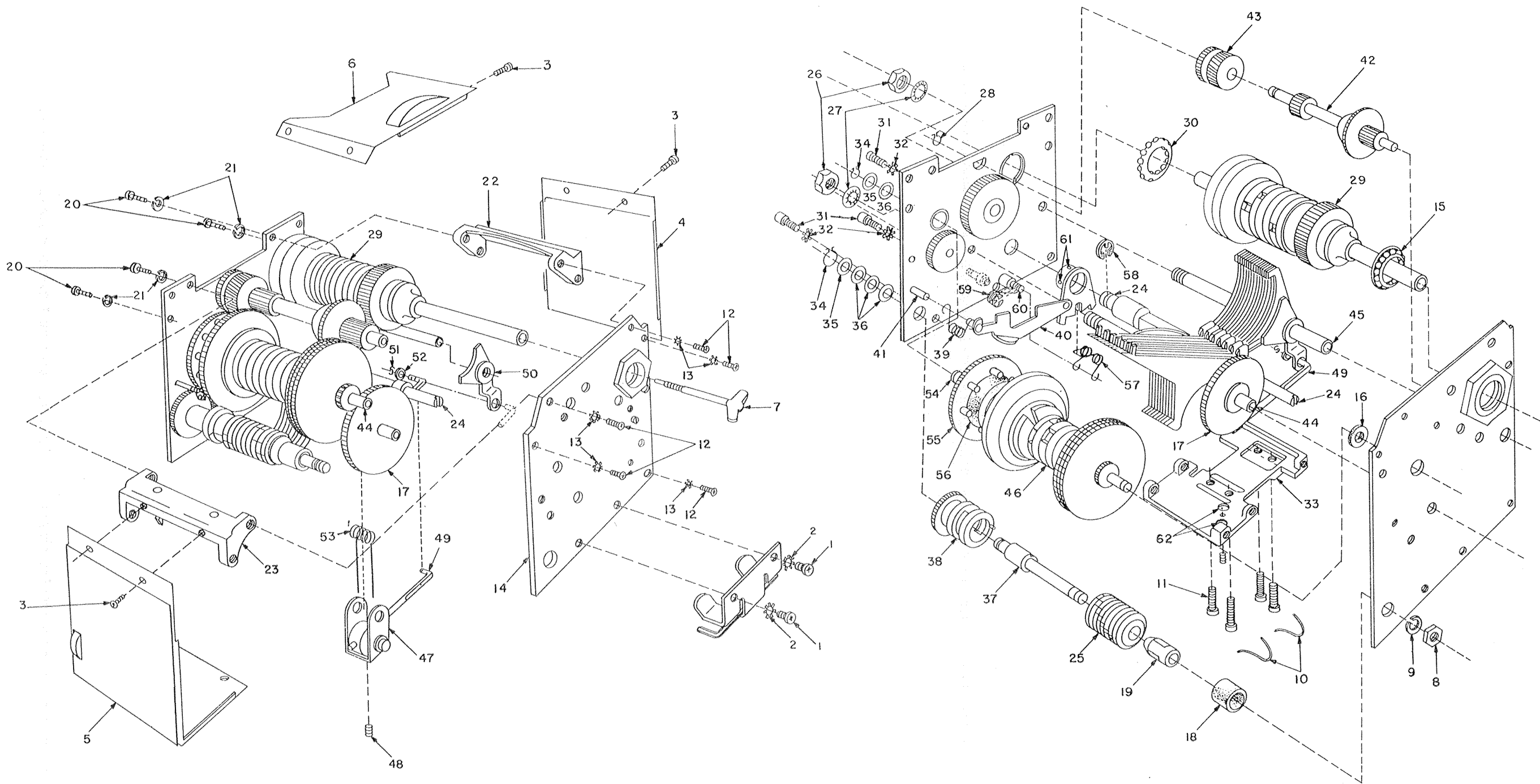

Figure 3-3. Disassembly of autotune multiturn head.

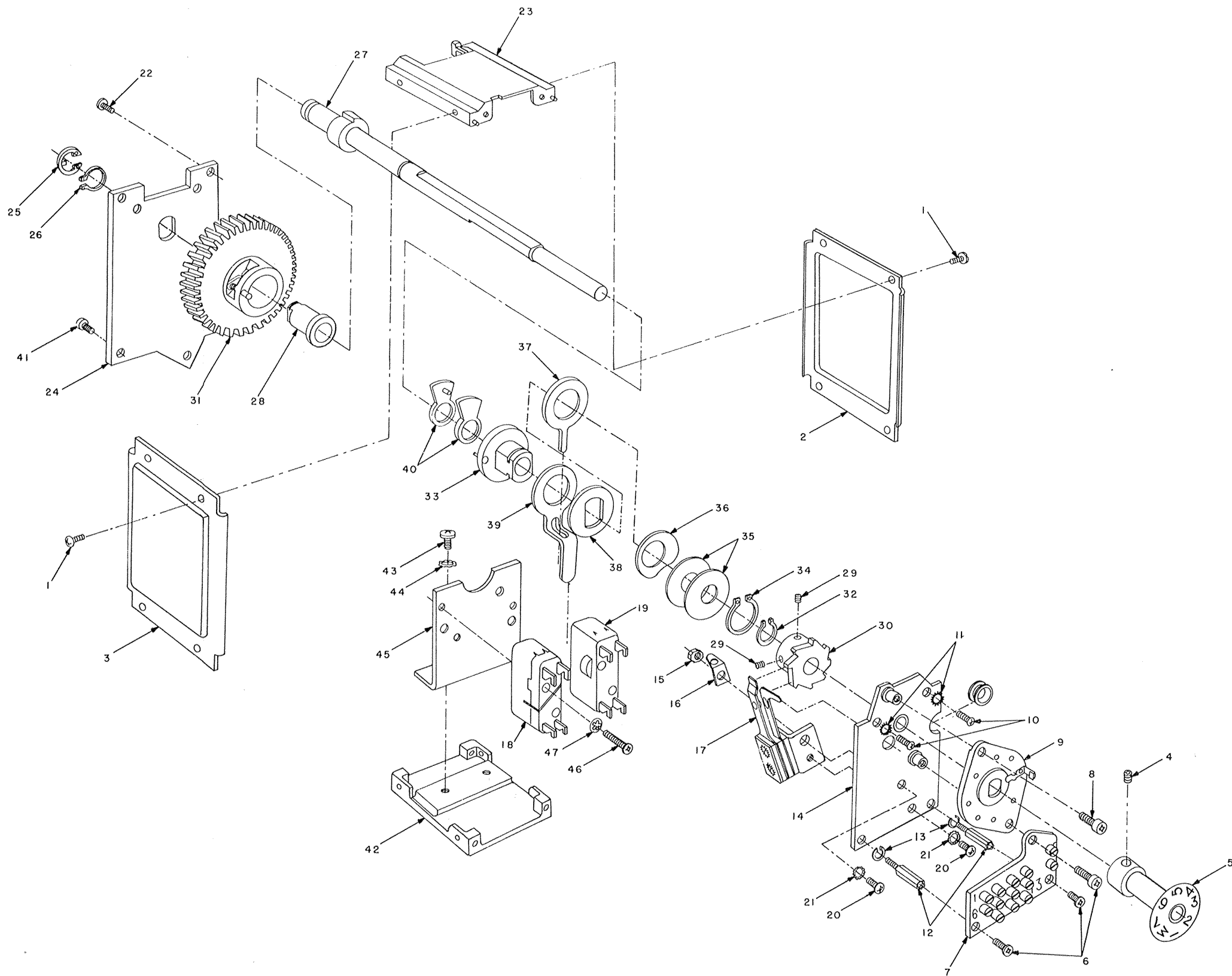

Figure 3-4. Disassembly of autotune control head.

## 5-4. Physical Tests and Inspection (fig. 5-2)

a. *Test Equipment and Materials.* None.

b. *Test Connections and Conditions.* The case of the radio-transmitter need not be removed for any of the tests. Do not connect power for this test.

c. *Procedure.*

Step No.	Test equipment control settings	Equipment under test control settings	Test procedure	Performance standard
1	None	None	<p>Remove and check each of the six fuses for proper rating.</p> <p>Remove the air intake cover and filter. Check the condition of the filter. Replace the filter and cover before proceeding.</p> <p>Check all three air port covers to insure that they are unsealed. Check the condition of the cover latches.</p> <p>Check the front panel for bent or broken connectors and terminals.</p> <p>Check the front panel for loose or missing parts such as screws, caps, or covers.</p> <p>Check the windows of the meters and indicators for breakage and cleanliness.</p> <p>Operate the following controls and switches throughout their limits of travel, or to their indicated switch positions, whichever is applicable: RELAY-NORMAL-DUPLEX, TEST METER, DIAL DIM, TEST KEY, LINE LEVEL, DIAL ZERO</p>	<p>Each fuse should be of the proper type and size as indicated on the panel.</p> <p>The filter should be clean, and no oil should drip when the filter is turned.</p> <p>All three covers should be unsealed. The cover latches should hold the covers securely.</p> <p>There should be no bent or broken terminals or connectors.</p> <p>There should be no loose or missing parts.</p> <p>All windows should be clean and free from cracks or breaks.</p> <p>All controls should turn freely without binding or excessive looseness. All knobs should be tight and properly indexed.</p>
2	None	None	<p>Turn the PRESET CHANNELS switch to each of its 8 positions.</p> <p><i>Note.</i> PRESET CHANNELS selector switch locks in the M position until the remainder spring is depressed.</p> <p>Unlock the BAND SELECTOR and TUNING CONTROL knobs.</p> <p>Turn the BAND SELECTOR control knob until the BAND-CHANNEL dial reading increases from 1.5-1.7 to 16-20.</p> <p>Turn the BAND SELECTOR knob until the BAND dial indicates 1.5-1.7 mc; then turn the TUNING CONTROL knob until the frequency indicator reading increases from 1,500 kc to 3,000 kc.</p> <p>Lock the BAND SELECTOR and TUNING CONTROL knobs by turning the locks clockwise until fingertight.</p>	<p>The PRESET CHANNELS switch should lock in the M position but turn freely to each of the other positions when the reminder spring is depressed.</p> <p>None.</p> <p>The BAND SELECTOR knob should rotate freely without binding or jamming.</p> <p>The TUNING CONTROL knob should rotate freely without binding or jamming.</p> <p>Locks must the control knobs with normal hand tightness.</p>
3	None	None	<p>Inspect the case for damage and condition of finish.</p> <p><i>Note.</i> Touch-up painting is recommended in lieu of refinishing whenever practicable. Screw heads, binding posts, and plated fastener parts will not be painted or polished with abrasives.</p>	<p>No damage should be evident. External painted surfaces should not show bare metal. Panel lettering should be legible.</p>



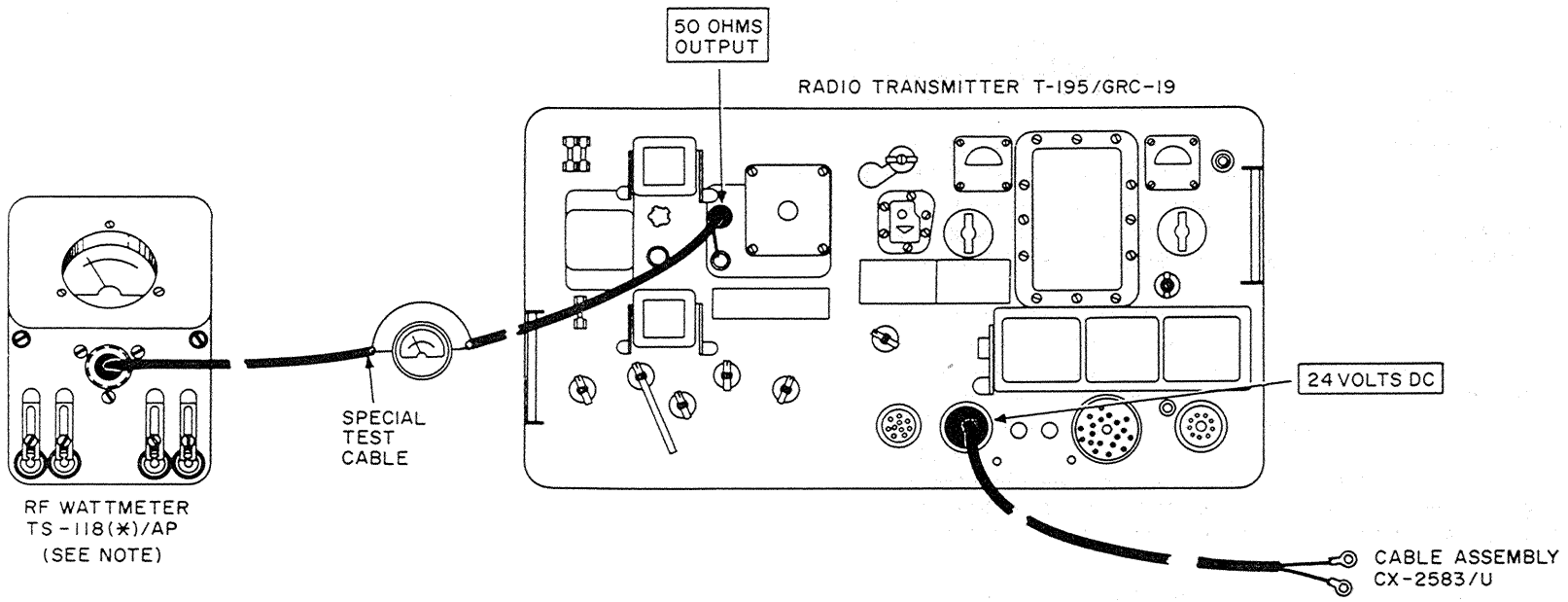

RF WATTMETER  
TS-118(\*)/AP  
(SEE NOTE)

SPECIAL  
TEST  
CABLE

50 OHMS  
OUTPUT

RADIO TRANSMITTER T-195/GRC-19

24 VOLTS DC

CABLE ASSEMBLY  
CX-2583/U

NOTE:

TO PREVENT DAMAGE TO THE METER MOVEMENT  
OF TS-118(\*)/AP, REMOVE AND DISCONNECT  
THE METER WHEN USING TS-118(\*)/AP AS A DUMMY  
LOAD.

TM 806-C5-3

Figure 5-3. Tuning capabilities and power output tests.

**5-5. Tuning Capabilities and Power Output Tests**  
(fig. 5-3)

*a. Test Equipment and Materials.*

TS-118/AP  
Special test cable  
Stop watch  
Cable Assembly CX-2583/U

*b. Test Connections and Conditions.* Connect the equipment as shown in figure 5-3.

*c. Procedure.*

Step No.	Test equipment control settings	Equipment under test control settings	Test procedure	Performance standard																								
1	Stop watch: Ready to time-----	SERVICE SELECTOR: OFF PRESET CHANNELS: M RELAY-NORMAL-DU- PLEX: NORMAL DIAL DIM: FULL TEST METER: PA GRID	Start the stop watch and set the SERVICE SELECTOR switch to CW simultaneously. When the dynamotor starts, stop the stop watch. Set the SERVICE SELECTOR switch to CALIBRATE and proceed to the next step.	Time interval should be not less than 30 seconds nor more than 50 seconds. None.																								
2	None -----	Same as at end of step No. 1	Unlock the BAND SELECTOR control by turning the lock at least 2 turns counterclockwise. Turn the BAND SELECTOR knob until the dial indicates 1.5-1.7 mc. Note and record the indication of the TEST METER. Rotate the BAND SELECTOR to each of the remaining seven bands. Note and record the TEST METER indication on each band. Lock the BAND SELECTOR in the 16-20 mc position by turning the lock clockwise until it is fingertight. Proceed to the next step.	None. TEST METER should indicate within or slightly to the right of the light colored area labeled PA GRID. Same as <i>b</i> above.																								
3	None -----	Same as at end of step No. 2.	Unlock TUNING CONTROL knob by turning the lock counterclockwise at least 2 turns. Observe the TEST METER indication while rotating the TUNING CONTROL manually throughout its entire range. Set the BAND SELECTOR to each of the bands, in turn, repeating <i>b</i> above for each band. Set the BAND SELECTOR to the 1-5-1.7 mc band as indicated on the BAND dial and lock it by turning the lock clockwise until fingertight. Set the TUNING CONTROL for 1.5-mc indication on the frequency indicator and lock it, using the same procedure. Proceed to the next step.	None. The TEST METER should indicate within the light-colored portion of the scale designated PA GRID, and should not vary sharply at any point. Same as <i>b</i> above.																								
4	None -----	Same as at end of step No. 3.	<p>Preset each of the seven channels in turn, following the procedure given below:</p> <ol style="list-style-type: none"> <li>(1) Turn the PRESET CHANNEL switch to the channel to be set. Wait until the autotune mechanism completes its operation before proceeding further.</li> <li>(2) Unlock the BAND SELECTOR and TUNING CONTROL and set each to the values indicated below. Lock both controls after setting before proceeding to the next channel.</li> </ol> <table border="1" style="margin-left: auto; margin-right: auto;"> <thead> <tr> <th>PRESET CHANNEL</th> <th>BAND</th> <th>TUNING CONTROL frequency indicator (mc)</th> </tr> </thead> <tbody> <tr><td>1</td><td>2.0-2.4</td><td>2.40</td></tr> <tr><td>2</td><td>3.0-4.0</td><td>3.40</td></tr> <tr><td>3</td><td>4.0-6.0</td><td>4.40</td></tr> <tr><td>4</td><td>6.0-9.0</td><td>7.00</td></tr> <tr><td>5</td><td>9.0-12.0</td><td>12.00</td></tr> <tr><td>6</td><td>12.0-16.0</td><td>15.00</td></tr> <tr><td>7</td><td>16.0-20.0</td><td>20.00</td></tr> </tbody> </table> <p>Set the PRESET CHANNEL switch to M and allow the autotune to complete its cycle before proceeding. Set the SERVICE SELECTOR to CW and listen for the high voltage dynamotor to start.</p> <p>Operate the TEST KEY to the ON position and observe the indication of the RF ammeter in the fabricated cable.</p> <p><i>Note.</i> It may be necessary to hold the TEST KEY operated for as long as 30-45 seconds before the autotune completes its cycle.</p> <p>Repeat <i>b</i> and <i>c</i> above for each of the remaining seven preset channels.</p>	PRESET CHANNEL	BAND	TUNING CONTROL frequency indicator (mc)	1	2.0-2.4	2.40	2	3.0-4.0	3.40	3	4.0-6.0	4.40	4	6.0-9.0	7.00	5	9.0-12.0	12.00	6	12.0-16.0	15.00	7	16.0-20.0	20.00	None. The dynamotor should start as soon as the autotune completes its cycle.
PRESET CHANNEL	BAND	TUNING CONTROL frequency indicator (mc)																										
1	2.0-2.4	2.40																										
2	3.0-4.0	3.40																										
3	4.0-6.0	4.40																										
4	6.0-9.0	7.00																										
5	9.0-12.0	12.00																										
6	12.0-16.0	15.00																										
7	16.0-20.0	20.00																										
5	None -----	Same as at end of step No. 4.	Rotate the DIAL DIM switch to the DIM and FULL positions respectively, and observe the dial lamps. Set the SERVICE SELECTOR switch to STANDBY and proceed to the next step.	The meter should indicate not less than 1.4 amperes after the autotune has completed its cycle. The TUNING INDICATOR lamp should light after tuning is completed. Same as above. The lamps should be lighted in both DIM and FULL positions and the degree of brightness should correspond to the switch position.																								

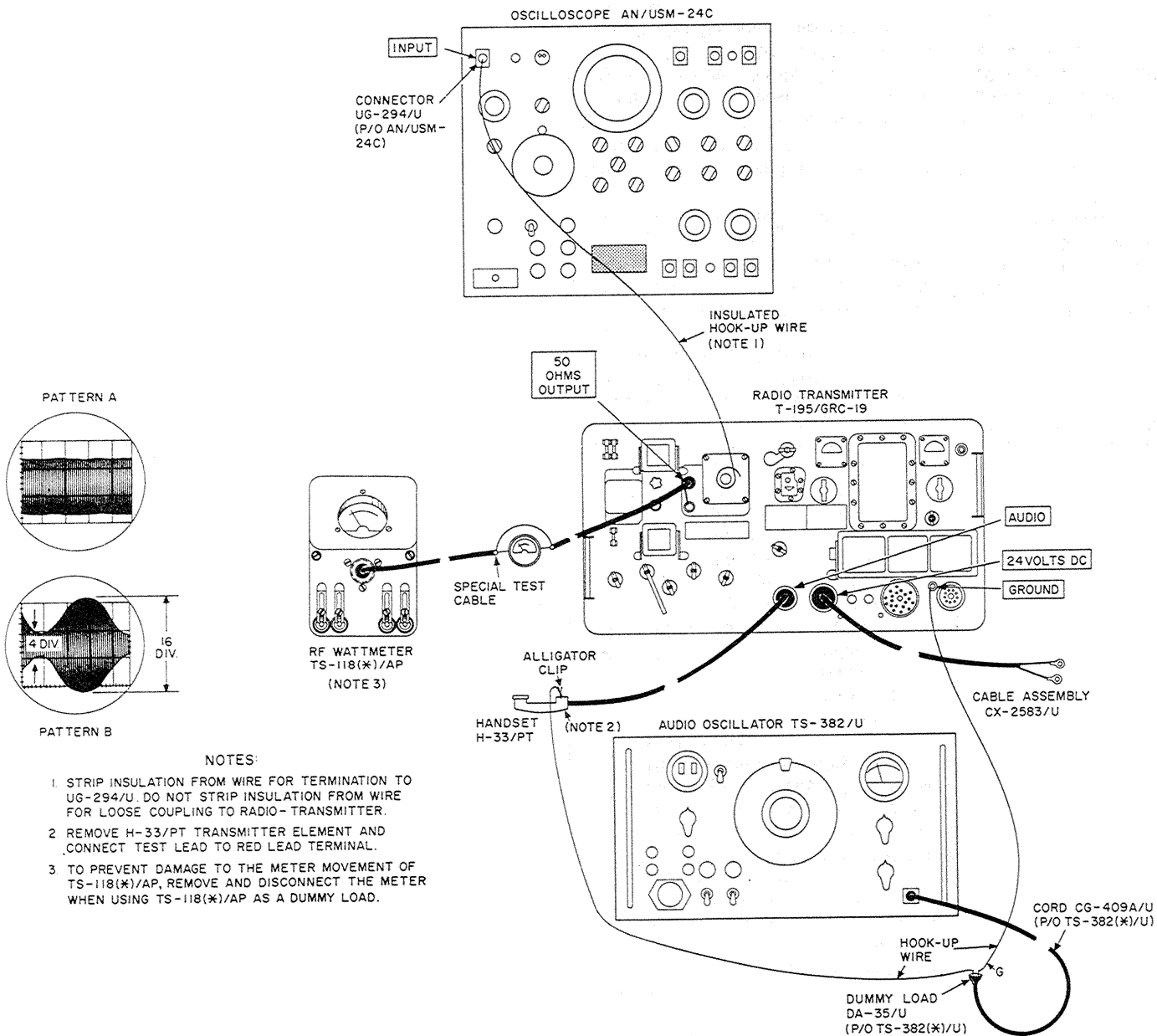

Figure 5-4. Modulation test.

